

Bluetooth® Low Energy 5.4 module

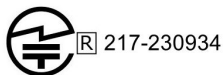

Features

- Integrated chip antenna, and option for external antenna
- Bluetooth® Low Energy 5.4 certified
- Supports 2 Mbits/s
- Frequency band: 2400 to 2483.5 MHz
- Advertising extension
- TX output power up to +5.5 dBm
- RX sensitivity: -96 dBm (1 Mbps)
- Range: TBD
- Dedicated Arm® Cortex®-M0+ for radio and security tasks
- Dedicated Arm® Cortex®-M4 CPU with FPU and ART (adaptive real-time accelerator), up to 64 MHz speed
- 320-Kbyte flash memory, 48-Kbyte SRAM
- Fully integrated BOM, including 32 MHz radio and 32 kHz RTC crystals
- Integrated SMPS
- Ultra-low power modes for battery longevity
- 27 GPIOs
- SWD, JTAG
- Integrated IPD for best-in-class and reliable antenna matching
- V_{DD} range: 1.71 to 3.6 V
- Temperature range: -40 to 85 °C
- Built-in security features, such as secure firmware installation (SFI) for radio stack, PKA, AES 256-bit, RNG, PCROP, CRC, 96-bit UID, possibility to derive 48-bit UEI
- Certifications: CE, FCC, ISED, JRF, RoHS, REACH, UKCA
- Planned certifications: KC, NCC, SRRC
- 2-layer PCB

Applications

- Home automation
- Wellness, healthcare, personal trackers
- Gaming and toys
- Beacons and accessories
- Industrial

Product status link

[STM32WB1MMC](#)

1 Introduction

This document provides the ordering information and mechanical device characteristics of the STM32WB1MMC module. It must be read in conjunction with DS13258 and RM0473, available on www.st.com.

For information on the Arm[®] Cortex[®] cores, refer to the Cortex[®] Technical Reference Manual, available from the www.arm.com website.

Note: Arm is a registered trademark of Arm Limited (or its subsidiaries) in the US and/or elsewhere.



2 Description

The STM32WB1MMC is an ultralow power, small form factor, certified 2.4 GHz wireless module, supporting Bluetooth® Low Energy 5.4. Based on the STM32WB15CCY wireless microcontroller, it provides best-in-class RF performance thanks to its good receiver sensitivity and a high output power signal. Its low power features enable extended battery life time, small coin-cell batteries, or energy harvesting.

The STM32WB1MMC requires no RF expertise, and is the best way to speed up the application development and to reduce the associated costs. The module is completely protocol stack royalty-free.

3 Module overview

The module is a SiP-LGA77 package (system in package land grid array), based on the proven STM32WB15CCY MCU. The package includes:

- LSE and HSE crystals
- Passive components for SMPS
- Antenna matching and antenna
- IPD for RF matching and harmonics rejection

Figure 1. Block diagram

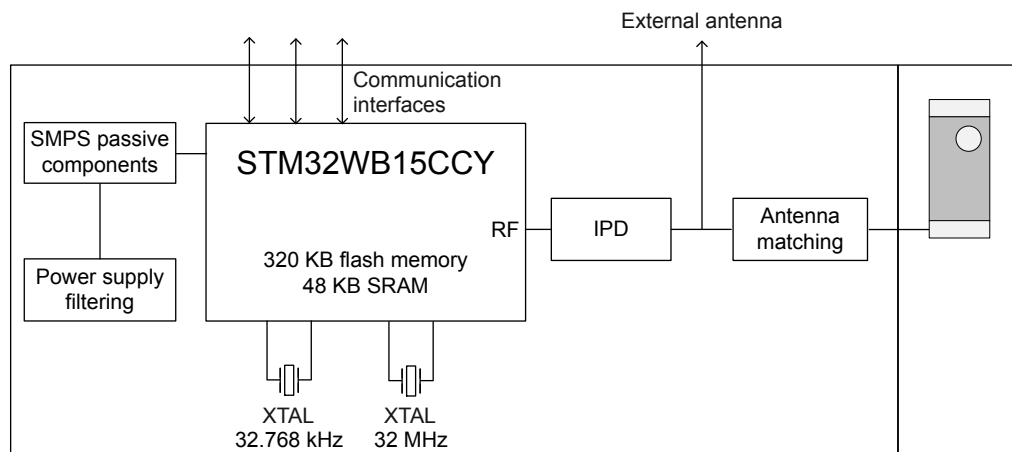

DT55981

3.1 Power supply

The power supply requirements are identical to those of the STM32WB1x devices, detailed in the datasheet DS13258. Filtering capacitors on power supply pins and components for the SMPS are already integrated into the module.

The SMPS passive components fitted in the module are in configuration-imposing function at 4 MHz, always ON. This is the only available configuration. For additional information on the SMPS, check the reference manual or AN5246, available on www.st.com.

3.2 Clocks

As the crystals are already integrated into the package, it is not possible to use any clock in bypass mode. The module integrates a 32.768 kHz crystal for LSE, and a 32 MHz crystal for the HSE clock.

- HSE is already tuned.
RCC_HSECR.HSETUNE[5:0] value is loaded automatically by hardware. The RCC_HSECR register configuration must not be changed by the user to keep the default parameters.
- LSCO and MCO outputs are available.

3.3 Antenna

The rectangular module has one shorter side clearly different from the remaining finish surface. This side is unshielded and the mold cover contains the integrated antenna.

To use the internal antenna, pins 6 (ANT_INT) and 7 (ANT_EXT) must be connected as in [Figure 2](#).

If an external antenna is used, ANT_IN must be shorted to ground, and ANT_OUT connected to the external antenna matching network and to the antenna itself, as in [Figure 3](#).

Note: Regulatory certifications obtained by ST apply only to the module with its internal antenna. Designs with external antennas require new certifications.

Figure 2. Connections when using the internal antenna

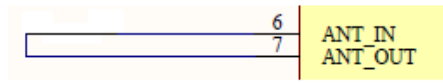
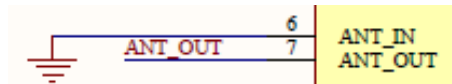

Figure 3. Connections when using an external antenna



3.4 OTP

The STM32WB1MMC features a 1-Kbyte one time programmable (OTP) memory for use by the end product (see DS13258 and RM0473).

Note: The device uses the first and last words of this area for trimming and identification purposes. As a consequence, addresses 0x1FFF7000h to 0x1FFF7007h and 0x1FFF73F8h to 0x1FFF73FFh cannot be changed.

4 Available peripherals

All the peripherals available in STM32WB series microcontrollers based on the WLCSP49 package are available and accessible on this module.

The pins on the module offer access to the following system peripherals:

- 1× DMA controllers (seven channels each) supporting ADC, SPI, I2C, USART, AES, timers
- 1× USART (ISO 7816, IrDA, SPI master, Modbus and Smartcard mode)
- 1× LPUART (low power)
- SPI running at 32 Mbit/s
- I²C (SMBus/PMBus[®])
- 1× touch sensing controller, up to 8 sensors
- 1× 16-bit, four-channel advanced timer
- 2× 16-bit, two-channel timers
- 1× 32-bit, four-channel timer
- 2× 16-bit ultra-low power timers
- 1× independent SysTick
- 1× independent watchdog
- 1× window watchdog.

The full pin description is available in DS13258.

5 Pin description

Figure 4 shows the module pinout package bottom view.

Figure 4. STM32WB1MMC module pinout: bottom view

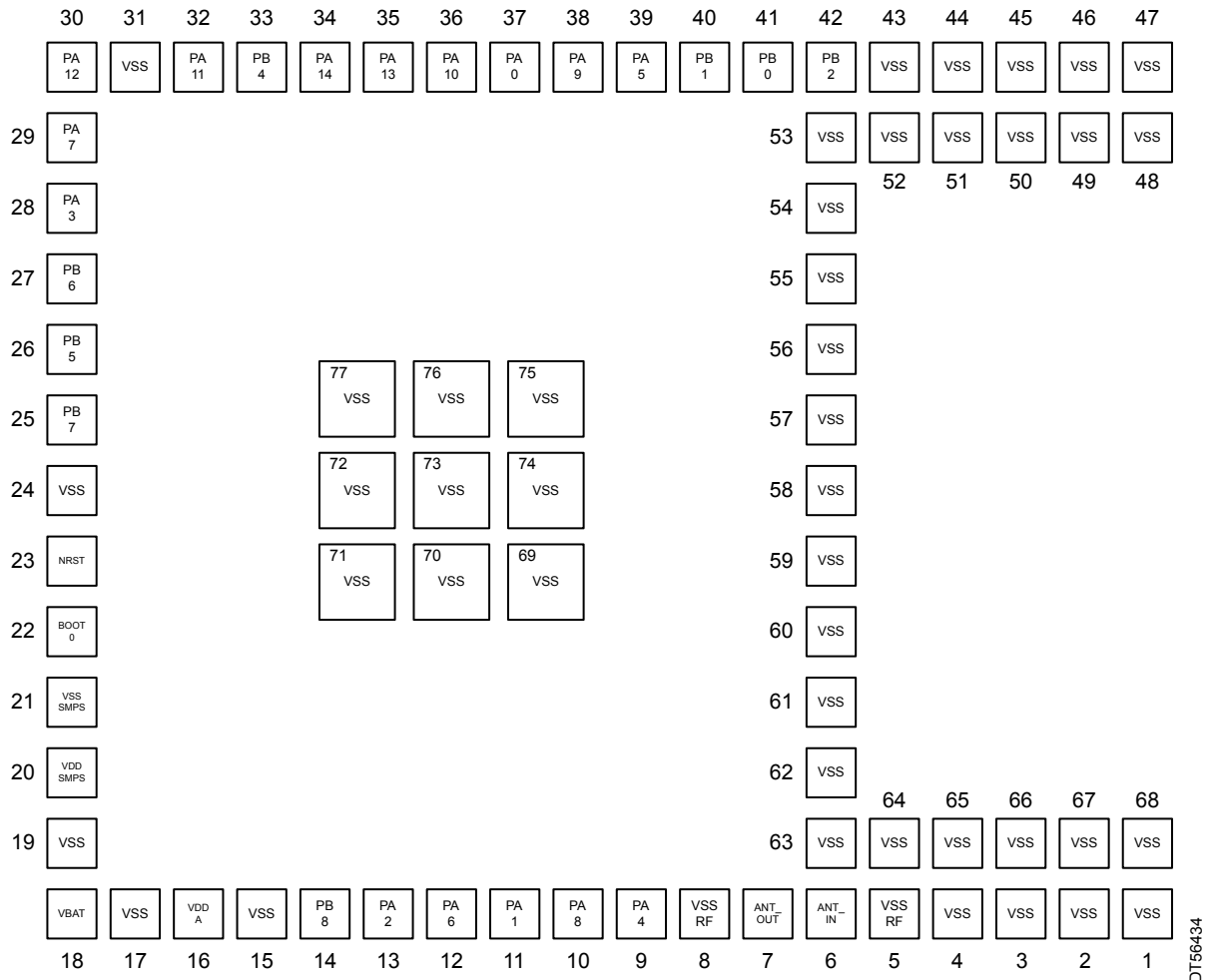

Table 1. STM32WB1MMC pin/ball definition

Pin name		Pin name (function after reset)	Pin type
STM32WB1MMC	STM32WB15CCY		
1	-	VSS	S
2	-	VSS	S
3	-	VSS	S
4	-	VSS	S
5	G1	VSSRF	S
6	-	ANT_IN	I
7	-	ANT_OUT	O
8	G3	VSSRF	S
9	G7	PA4	I/O

Pin name		Pin name (function after reset)	Pin type
STM32WB1MMC	STM32WB15CCY		
10	G6	PA8	I/O
11	F7	PA1	I/O
12	F6	PA6	I/O
13	E6	PA2	I/O
14	C6	PB8	I/O
15	-	VSS	S
16	E7	VDDA	S
17	-	VSS	S
18	C5	VBAT	S
19	-	VSS	S
20	A1	VDDSMPS	S
21	C1	VSSMPS	S
22	B6	BOOT0	I/O
23	C7	NRST	I/O
24	-	VSS	S
25	A6	PB7	I/O
26	A5	PB5	I/O
27	B5	PB6	I/O
28	D5	PA3	I/O
29	E5	PA7	I/O
30	A3	PA12	I/O
31	-	VSS	S
32	A2	PA11	I/O
33	B4	PB4	I/O
34	B3	PA14	I/O
35	B2	PA13	I/O
36	C2	PA10	I/O
37	C4	PA0	I/O
38	D3	PA9	I/O
39	D4	PA5	I/O
40	E1	PB1	I/O
41	E2	PB0	I/O
42	E4	PB2	I/O
43	-	VSS	S
44	-	VSS	S
45	-	VSS	S
46	-	VSS	S
47	-	VSS	S
48	-	VSS	S
49	-	VSS	S

Pin name		Pin name (function after reset)	Pin type
STM32WB1MMC	STM32WB15CCY		
50	-	VSS	S
51	-	VSS	S
52	-	VSS	S
53	-	VSS	S
54	-	VSS	S
55	-	VSS	S
56	-	VSS	S
57	-	VSS	S
58	-	VSS	S
59	-	VSS	S
60	-	VSS	S
61	-	VSS	S
62	-	VSS	S
63	-	VSS	S
64	-	VSS	S
65	-	VSS	S
66	-	VSS	S
67	-	VSS	S
68	-	VSS	S
69	-	VSS	S
70	-	VSS	S
71	-	VSS	S
72	-	VSS	S
73	-	VSS	S
74	-	VSS	S
75	-	VSS	S
76	-	VSS	S
77	-	VSS	S

6 Schematics

Figure 5. Reference board schematics

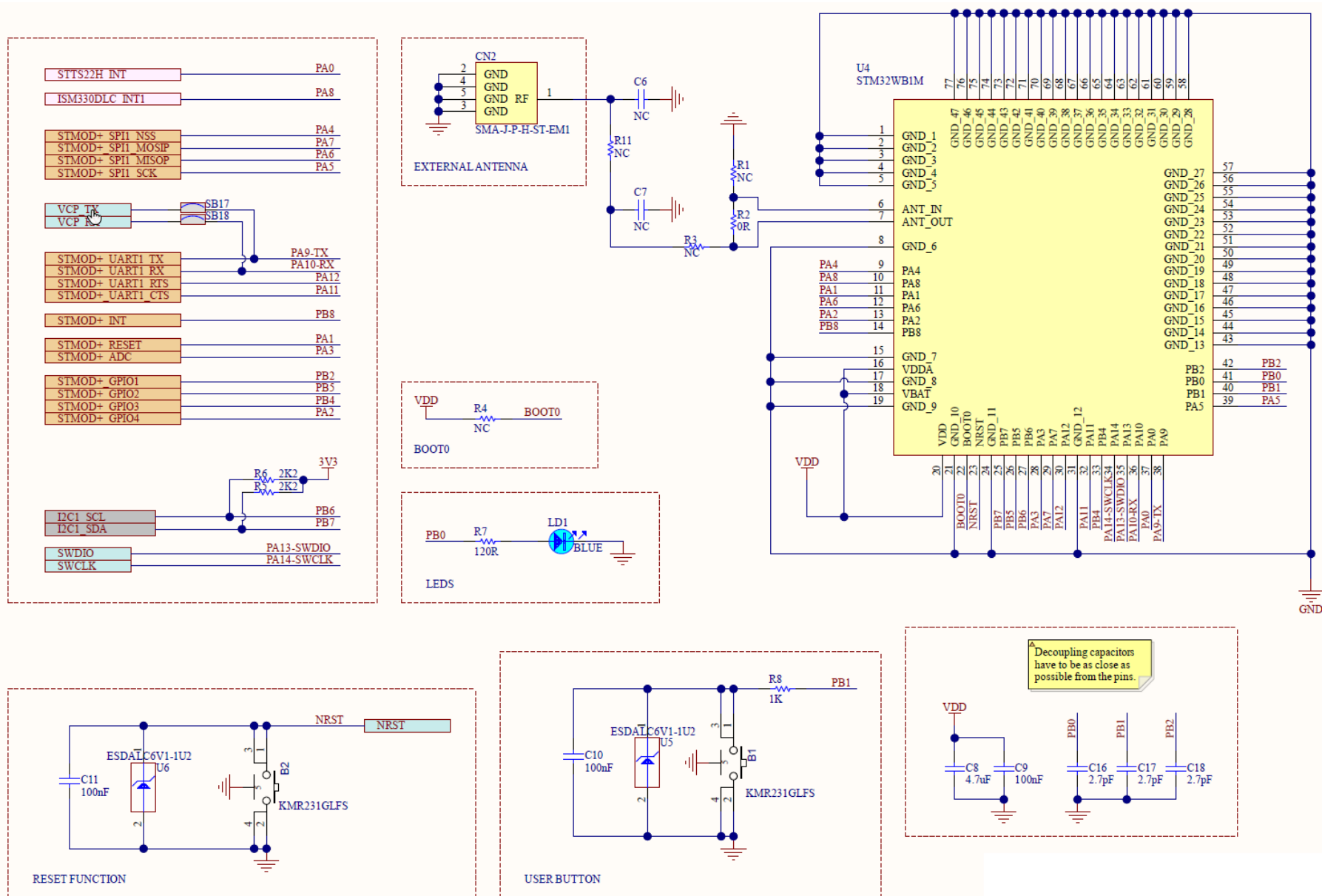

Figure 6. Top layer

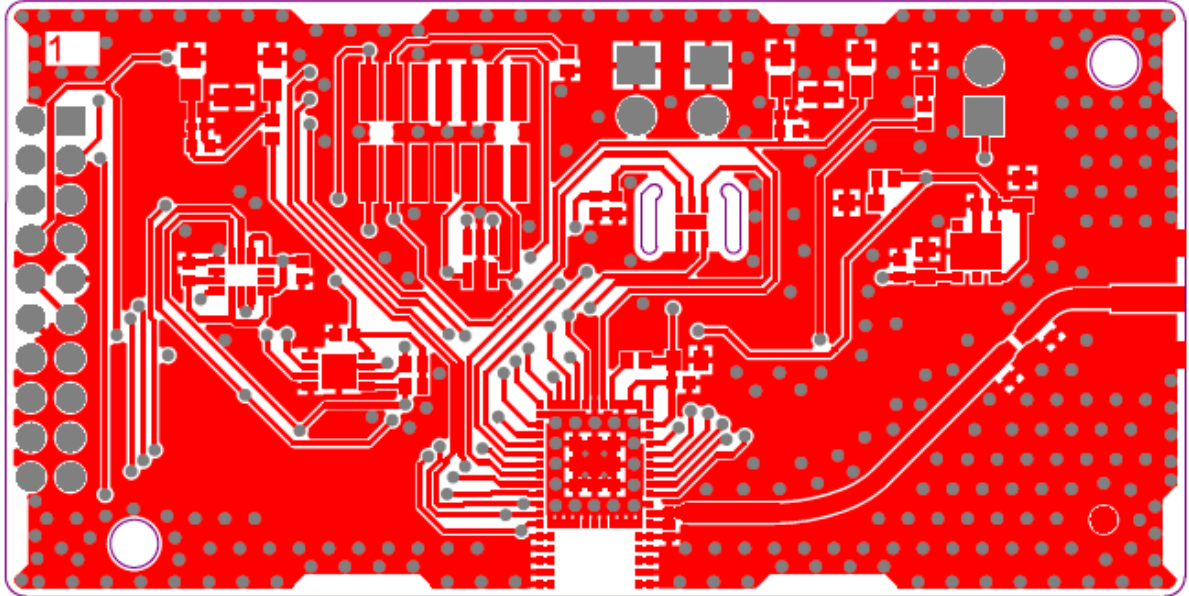
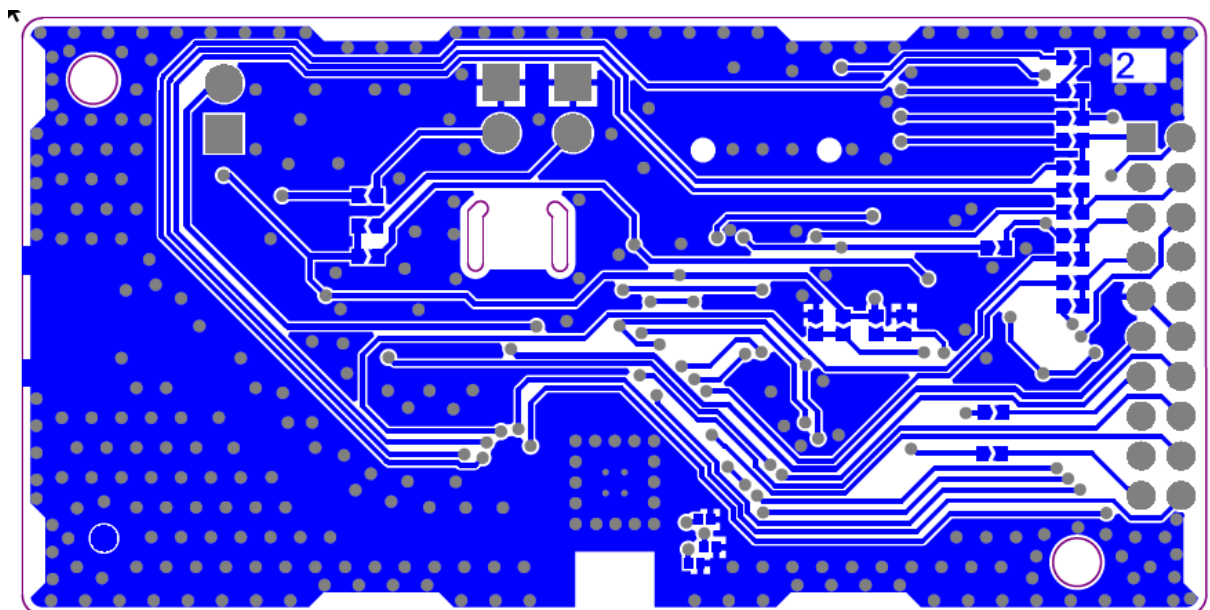

Figure 7. Bottom layer



Sensitive GPIOs

Among the multiple GPIOs available on this product, three are particularly sensitive, namely PB0, PB1, and PB2. If possible, do not use them, and do not connect these pins. If they must be used, ensure that the connections are made with very short wires, to avoid the creation of parasitic antennas. In addition, place a small scale factor (such as 201) 2.7 pF capacitor as close as possible to the output pin, and border these tracks with the ground plane.

Layout recommendations

Decoupling capacitors must be placed as close as possible to the pins.

100 nF capacitors on external supplies must be placed as close as possible to the supply pads of the MEMs.

8 Electrical characteristics

8.1 Operating conditions

Table 2. STM32WB1MMC operating conditions

Parameter	Min	Typ	Max	Unit
V _{DD}	1.71	3.3	3.6	V
Operating ambient temperature range	-40	-	85	°C
Storing temperature range	-40	-	125	

8.2 Power consumption

The power consumption is identical to the regular STM32WB15. For full details refer to DS13258.

8.3 RF characteristics

Refer to DS13258.

8.4 Antenna radiation patterns and efficiency

The following figures present the radiation patterns, taken from certification measurements.

Figure 8. Radiaton pattern - 2402 MHz

2D Diagram

Plan measured C_{min} : 2402 MHz

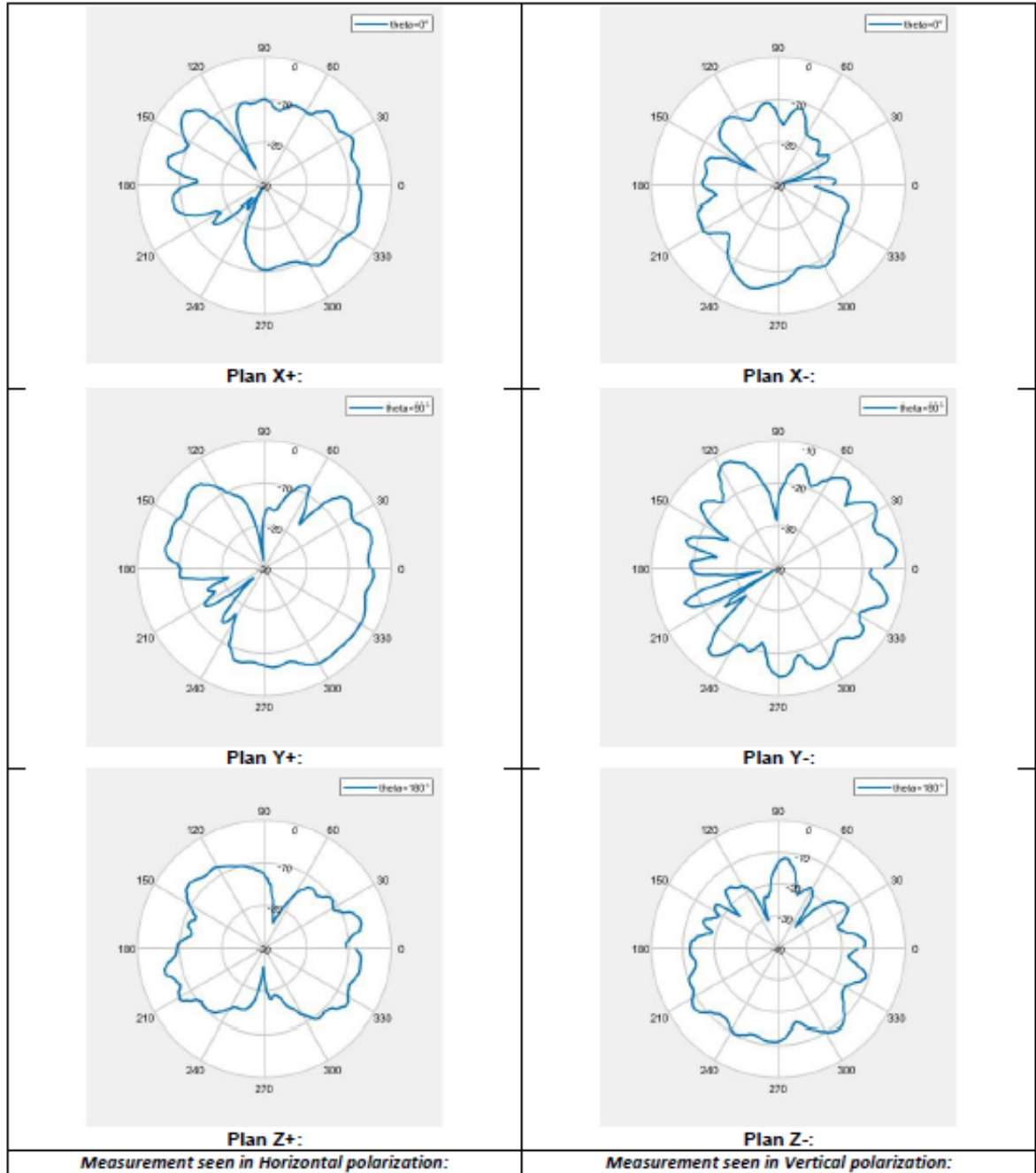

Figure 9. Radiaton pattern - 2440 MHz

Plan measured C_{mig} : 2440 MHz

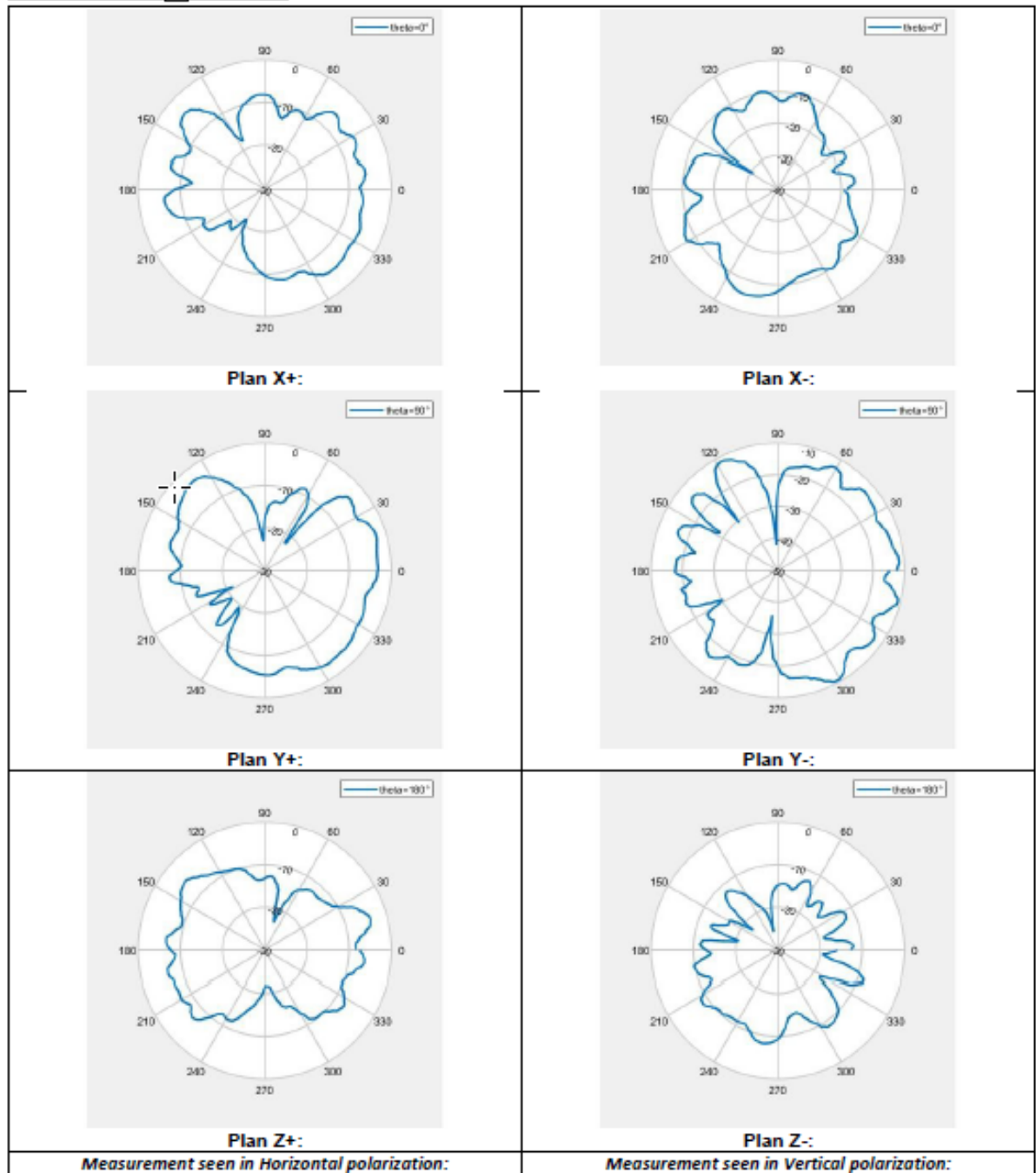
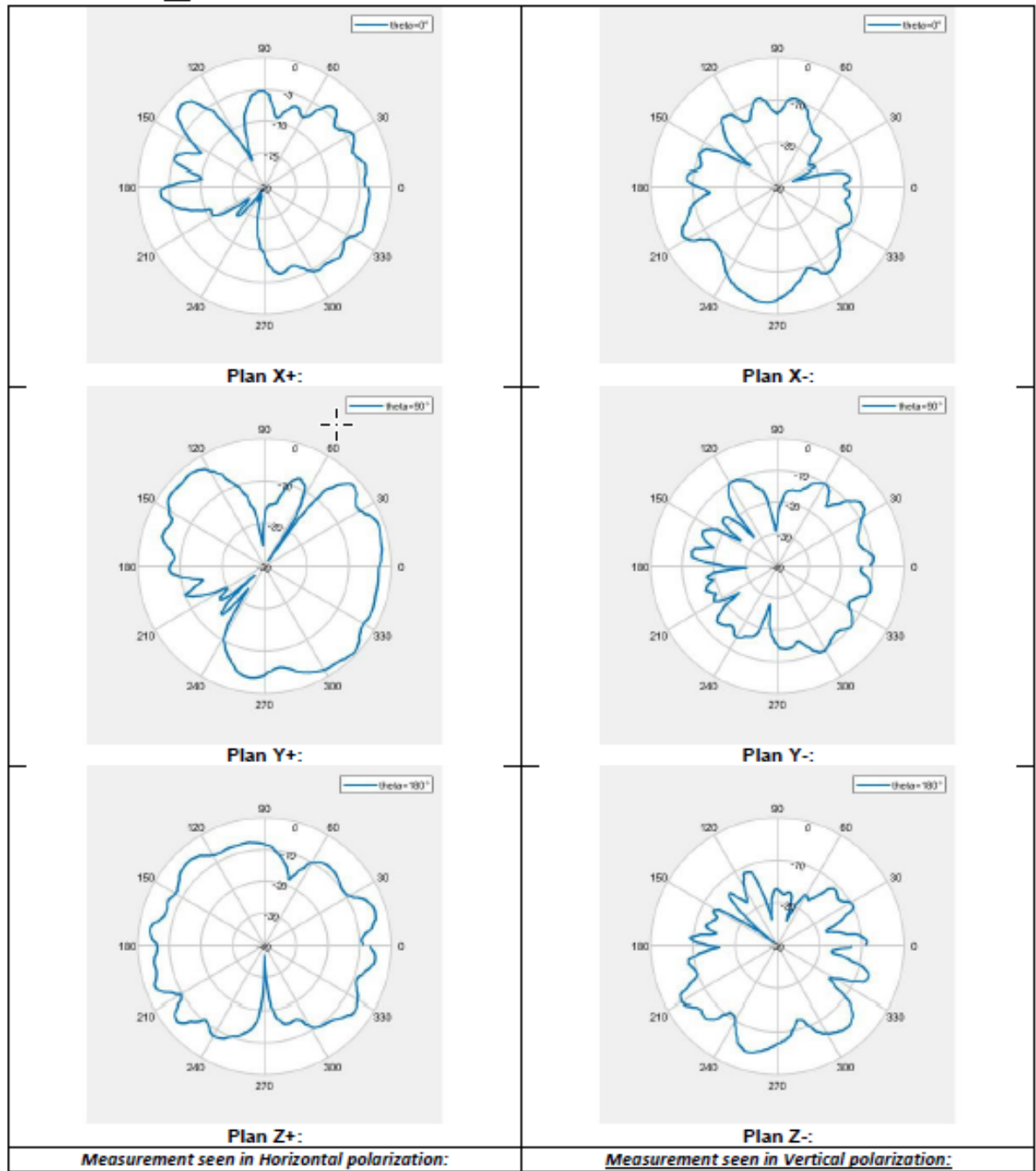

Figure 10. Radiaton pattern - 2480 MHz

Plan measured C_{max} : 2480 MHz



9 Package information

In order to meet environmental requirements, ST offers these devices in different grades of **ECOPACK** packages, depending on their level of environmental compliance. ECOPACK specifications, grade definitions and product status are available at: www.st.com. ECOPACK is an ST trademark.

9.1 Device marking for SiP-LGA77

Refer to technical note “Reference device marking schematics for STM32 microcontrollers and microprocessors” (TN1433) available on www.st.com, for the location of pin 1 / ball A1, as well as the location and orientation of the marking areas versus pin 1 / ball A1.

Parts marked as “ES”, “E” or accompanied by an Engineering Sample notification letter, are not yet qualified and therefore not approved for use in production. ST is not responsible for any consequences resulting from such use. In no event will ST be liable for the customer using any of these engineering samples in production. ST’s Quality department must be contacted prior to any decision to use these engineering samples to run a qualification activity.

9.2 LGA77 package information (B0HQ)

This LGA is a 77-lead, 10 x 6.5 mm, 0.45/0.50 mm pitch, land grid array package.

Figure 11. LGA77 - Outline

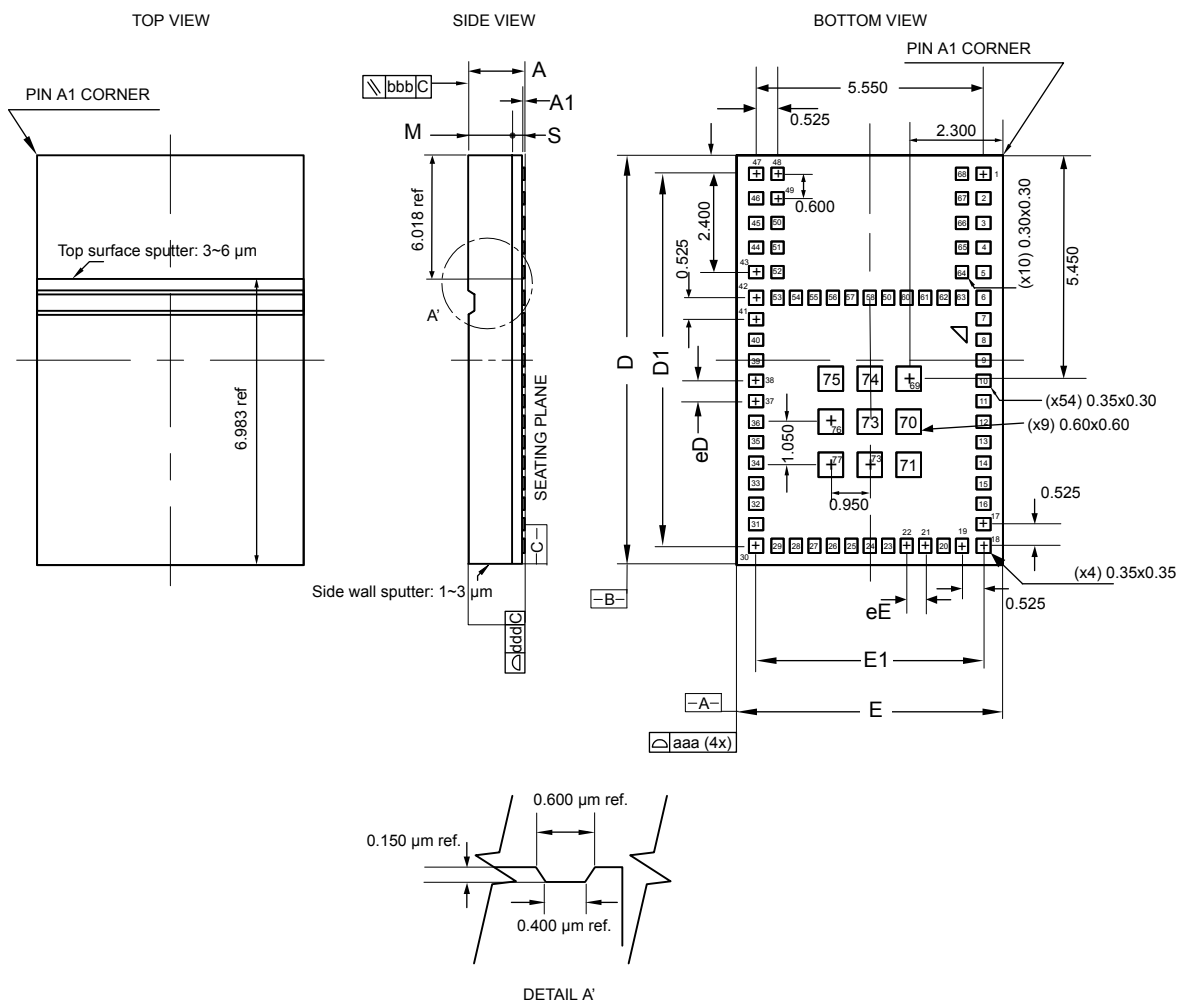

1. All dimensions, except where are indicated, are in millimeters.
2. Drawing is not in scale.

Table 3. LGA77 - Mechanical data

Symbol	millimeters			inches		
	Min	Typ	Max	Min	Typ	Max
A	1.372 ± 0.046			0.0540 ± 0.0018		
A1	0.030 ± 0.020			0.0012 ± 0.0008		
D	9.900	10.000	10.100	0.3898	0.3937	0.3976
E	6.400	6.500	6.600	0.2520	0.2559	0.2598
D1	9.075			0.3573		
E1	5.550			0.2185		
eD	0.500			0.0197		
eE	0.450			0.0177		
M	1.100 REF			0.0433 REF		
S	0.24 REF			0.0094 REF		
Lead width	0.300 x 0.300			0.118 x 0.0118		
	0.350 x 0.300			0.0138 x 0.0118		
	0.350 x 0.350			0.0138 x 0.0138		
	0.600 x 0.600			0.0236 x 0.0236		
aaa	0.100			0.0039		
bbb	0.100			0.0039		
ddd	0.100			0.0039		

1. Values in inches are converted from mm and rounded to four decimal digits.

9.3 Thermal characteristics

The device thermal characteristics are defined below, and the constant values are given in [Table 4](#):

- Θ_{JA} is the junction-to-ambient thermal resistance (EIA/JESD51-2 and EIA/JESD51-6)
 Θ_{JA} represents the resistance to the heat flowing from the chip to ambient air. It is an indicator of package heat dissipation capability, a lower Θ_{JA} means better overall thermal performance. It is calculated as follows:

$$\Theta_{JA} = (T_J - T_A) / P_H$$
 where:
 - T_J = junction temperature
 - T_A = ambient temperature
 - P_H = power dissipation.
- Ψ_{JT} is the junction-to-top-center thermal characterization parameter (EIA/JESD51-2 and EIA/JESD51-6).
 Ψ_{JT} is used for estimating the junction temperature by measuring T_T in an actual environment. It is calculated as follows:

$$\Psi_{JT} = (T_J - T_T) / P_H$$
 where T_T = temperature at the top-center of the package.
- Θ_{JC} is the junction-to-case thermal resistance.
 Θ_{JC} represents the resistance to the heat flowing from the chip to package top case. Θ_{JC} is important when an external heat sink is attached on package top. It is calculated as follows:

$$\Theta_{JC} = (T_J - T_C) / P_H$$
 where T_C = case temperature attached with a cold plate.

- Θ_{JB} is the junction-to-board thermal resistance (EIA/JESD51-8).
 Θ_{JB} represents the resistance to the heat flowing from the chip to PCB. Θ_{JB} is used in compact thermal models for system-level thermal simulation. It is calculated as follows:
 $\Theta_{JB} = (T_J - T_B) / P_H$
 where T_B = board temperature with ring cold plate fixture applied.

Table 4. Thermal characteristics

Symbol	Max T_J (° C)	T_T (° C)	Ψ_{JT} (° C/W)	Θ_{JA} (° C/W)	Θ_{JB} (° C/W)	Θ_{JC} (° C/W)
Value	99.65	99.53	0.26	37.36	16.96	14.41

9.4 Board design

For information and recommendations related to board design, landing pads, stencils and the solder reflow profile for LGA packages, refer to AN 5886 "Guidelines for design and board assembly of land grid array packages", available on www.st.com.

10 Ordering information

Table 5. Ordering information scheme

Example:	STM32	WB	1	M	M	C	H	6	TR
Device family									
STM32 = Arm-based 32-bit microcontroller									
Product type									
WB = wireless Bluetooth									
Device subfamily									
1 = STM32WB15 die 1, full set of features									
Pin count									
M = 77 pins									
Component type									
M = module									
Flash memory size									
C = 320 Kbytes									
Package									
H = LGA77 6.5 x 10 mm									
Temperature range									
6 = industrial temperature range, -40 to 85 °C									
Packing									
TR = tape and reel									

For a list of available options (such as speed and package) or for further information on any aspect of this device, contact your nearest ST sales office.

11 Tape and reel

The module tape, the reel orientation, and the dimensions are shown in Figure 12.

Figure 12. STM32WB1MMC tape and reel

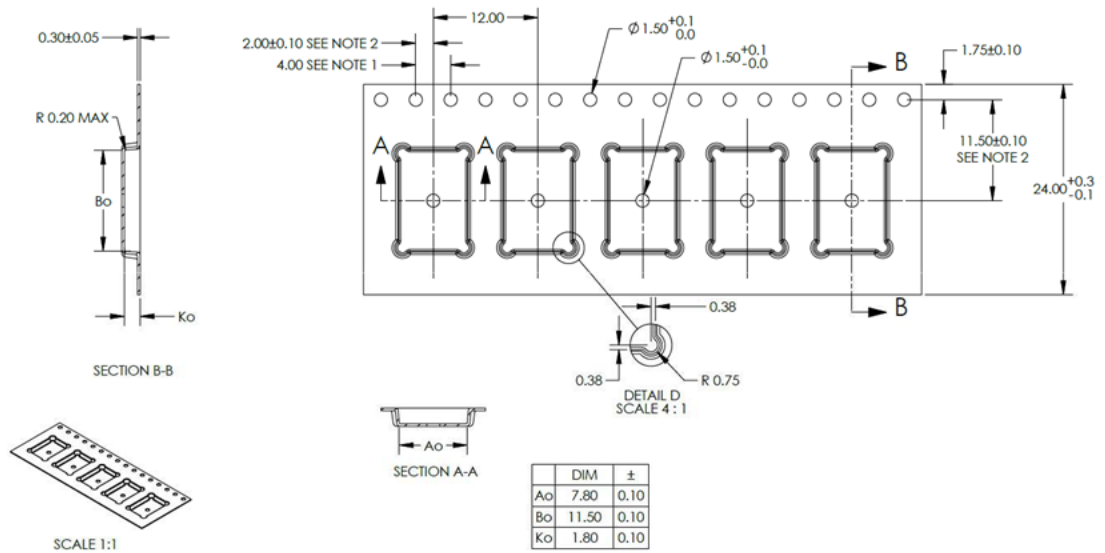

- NOTES:
- 10 SPROCKET HOLE PITCH CUMULATIVE TOLERANCE ± 0.2
 - POCKET POSITION RELATIVE TO SPROCKET HOLE MEASURED AS TRUE POSITION OF POCKET, NOT POCKET HOLE.
 - Ao AND Bo ARE MEASURED ON A PLANE AT A DISTANCE "R" ABOVE THE BOTTOM OF THE POCKET.

12 Certifications

The STM32WB1MMC module, with its internal antenna, has passed the following certifications:

- BLE (RF_PHY)
- CE (RED)
- FCC
- ISED
- REACH
- ROHS

Certifications for UK, Japan, Korea, Taiwan and China (SRRC) are in progress. All certification reports are available on the STM32WB1MMC webpage.

12.1 BLE(RF_PHY) certification

The module has obtained BLE RF_PHY certification.
 The module is published under BLE SIG web site.

12.2 CE certification

The STM32WB1MMC module has obtained CE certification.
 The module is provided with CE marking.

Figure 13. CE certification logo



12.3 FCC certification

The STM32WB1MMC module complies with part 15 of the FCC Rules.
 The FCC ID is YCP-32WB1MMCH01.
 The module label includes the corresponding FCC ID.
 The operation is subject to the following two conditions:

- This device may not cause harmful interference
- This device must accept any interference received, including interference that may cause undesired operation.

Note: This equipment has been tested and found to comply with the limits for a Class B digital device, pursuant to part 15 of the FCC Rules. These limits are designed to provide reasonable protection against harmful interference in a residential installation.

Label requirements

If the identification number is not visible when the module is installed inside another device, then the outside of the device into which the module is installed must also display a label referring to the enclosed module. This label must contain the FCC ID that matches the one on the module.

RF radiation exposure statement caution

The module antenna must be installed to meet the RF exposure compliance separation distance of “20 cm” and any additional testing and authorization processes as required.

Documentation requirements

The users manual or instruction manual for an intentional or unintentional radiator shall caution the user that changes or modifications not expressly approved by the party responsible for compliance could void the user's authority to operate the equipment.

Integration requirements

Co-location of this module with other transmitters that operate simultaneously are required to be evaluated using the multi-transmitter procedures.

The host integrator must follow the integration instructions provided in this document and ensure that the composite-system end product complies with the requirements by a technical assessment or evaluation to the rules and to KDB Publication 996369.

The host integrator installing this module into their product must ensure that the final composite product complies with the requirements by a technical assessment or evaluation to the rules, including the transmitter operation and should refer to guidance in KDB 996369.

12.4 ISED certification

The STM32WB1MMC module has been tested and found compliant with the ISED RSS-247 and RSS-Gen rules. The IC ID is 8976A-32WB1MMCH01.

This module contains license-exempt transmitter(s) that comply with Innovation, Science and Economic Development Canada's license-exempt RSS(s). Operation is subject to the following two conditions:

- This module may not cause interference
- This module must accept any interference, including interference that may cause undesired operation of the module.

L'émetteur exempt de licence contenu dans le présent appareil est conforme aux CNR d'Innovation, Sciences et Développement économique Canada applicables aux appareils radio exempts de licence. L'exploitation est autorisée aux deux conditions suivantes :

- L'appareil ne doit pas produire de brouillage.
- L'appareil doit accepter tout brouillage radioélectrique subi, même si le brouillage est susceptible d'en compromettre le fonctionnement.

RF radiation exposure statement caution

This Transmitter must be installed to provide a separation distance of at least 20 cm from all persons.

12.5 JRF certification

The STM32WB1MMC module is certified in Japan with certification number 217-230934.

Figure 14. JRF logo



Revision history

Table 6. Document revision history

Date	Version	Changes
03-Mar-2023	1	Initial release.
28-Jul-2023	2	Updated Features and Sensitive GPIOs . Added certification logos on cover page. Updated Figure 4. STM32WB1MMC module pinout: bottom view . Added Section 12.5 JRF certification . Minor text edits across the whole document.
05-Sep-2023	3	Updated document title and image on cover page. Updated Features and Section 2 Description .

Contents

1	Introduction	2
2	Description	3
3	Module overview	4
3.1	Power supply	4
3.2	Clocks	4
3.3	Antenna	4
3.4	OTP	5
4	Available peripherals	6
5	Pin description	7
6	Schematics	10
7	PCB	11
8	Electrical characteristics	13
8.1	Operating conditions	13
8.2	Power consumption	13
8.3	RF characteristics	13
8.4	Antenna radiation patterns and efficiency	13
9	Package information	17
9.1	Device marking for SiP-LGA77	17
9.2	LGA77 package information (B0HQ)	17
9.3	Thermal characteristics	18
9.4	Board design	19
10	Ordering information	20
11	Tape and reel	21
12	Certifications	22
12.1	BLE(RF_PHY) certification	22
12.2	CE certification	22
12.3	FCC certification	22
12.4	ISED certification	23
12.5	JRF certification	23
	Revision history	24
	List of tables	26
	List of figures	27

List of tables

Table 1.	STM32WB1MMC pin/ball definition	7
Table 2.	STM32WB1MMC operating conditions	13
Table 3.	LGA77 - Mechanical data	18
Table 4.	Thermal characteristics.	19
Table 5.	Ordering information scheme.	20
Table 6.	Document revision history	24

List of figures

Figure 1.	Block diagram	4
Figure 2.	Connections when using the internal antenna.	5
Figure 3.	Connections when using an external antenna.	5
Figure 4.	STM32WB1MMC module pinout: bottom view	7
Figure 5.	Reference board schematics	10
Figure 6.	Top layer	11
Figure 7.	Bottom layer.	11
Figure 8.	Radiation pattern - 2402 MHz	14
Figure 9.	Radiation pattern - 2440 MHz	15
Figure 10.	Radiation pattern - 2480 MHz	16
Figure 11.	LGA77 - Outline	17
Figure 12.	STM32WB1MMC tape and reel	21
Figure 13.	CE certification logo	22
Figure 14.	JRF logo	23

IMPORTANT NOTICE – READ CAREFULLY

STMicroelectronics NV and its subsidiaries (“ST”) reserve the right to make changes, corrections, enhancements, modifications, and improvements to ST products and/or to this document at any time without notice. Purchasers should obtain the latest relevant information on ST products before placing orders. ST products are sold pursuant to ST’s terms and conditions of sale in place at the time of order acknowledgment.

Purchasers are solely responsible for the choice, selection, and use of ST products and ST assumes no liability for application assistance or the design of purchasers’ products.

No license, express or implied, to any intellectual property right is granted by ST herein.

Resale of ST products with provisions different from the information set forth herein shall void any warranty granted by ST for such product.

ST and the ST logo are trademarks of ST. For additional information about ST trademarks, refer to www.st.com/trademarks. All other product or service names are the property of their respective owners.

Information in this document supersedes and replaces information previously supplied in any prior versions of this document.

© 2023 STMicroelectronics – All rights reserved