

# APPROVAL SHEET

To :

Customer P/N :

UDE P/N : RT7-ZZ-0117

Description : RJ45 1X1 Tab Up

Through Hole

10/100 Base-T

Contact Area : 30 $\mu$ " Min. Gold

LED : L-Yellow; R-Green



Spec No.  
RT717103-00

Update Date  
2017/9/6

Revision  
A

Approved	Checked	Prepared



湧德電子 股份有限公司  
UDE Corp.

桃園市(33852) 蘆竹區內溪路 68 巷13號

No.13, Ln. 68, Neixi Rd., Luzhu Dist., Taoyuan City (33852), Taiwan

TEL: 886-3-3242000 FAX: 886-3-3246611

<http://www.ude-corp.com/>



1. MECHANICAL DIMENSION

Product Dimension

Unit:mm	General Tolerance :	X.X : ± 0.38
		X.XX : ± 0.20

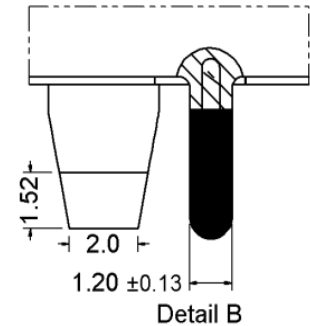
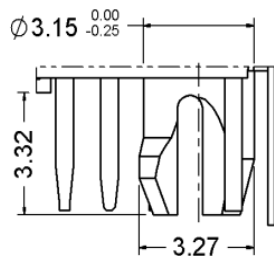
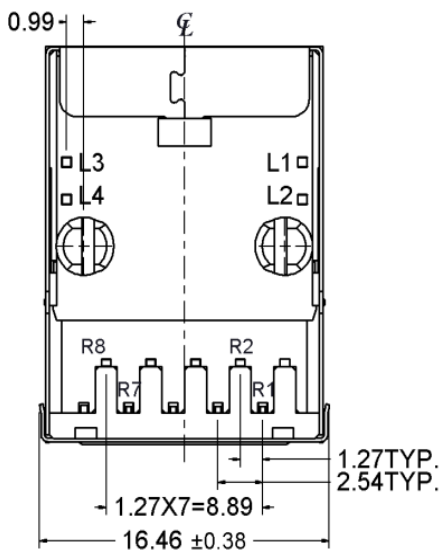
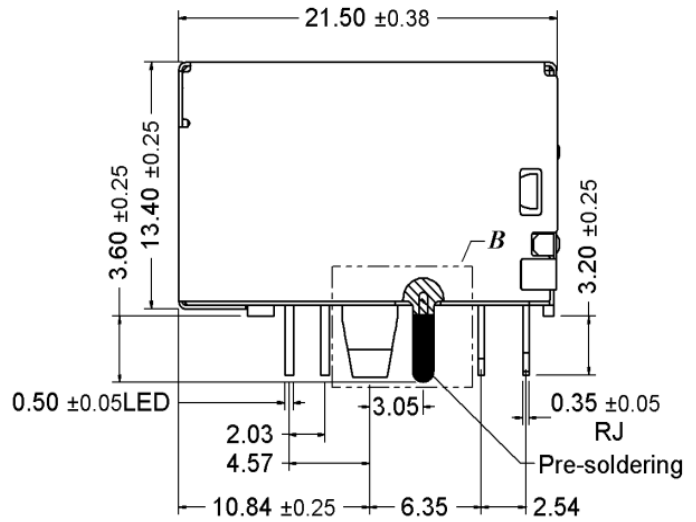
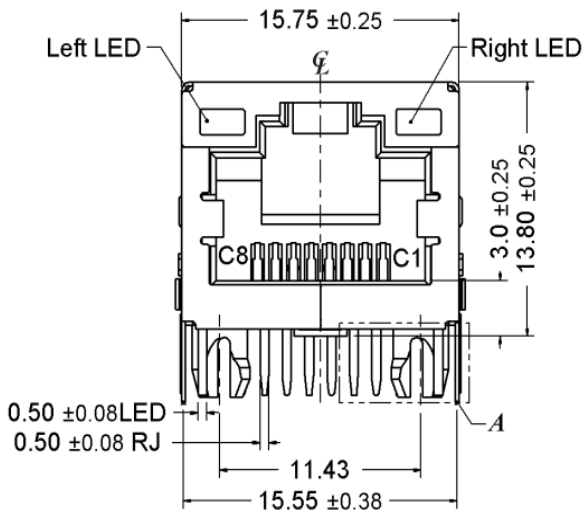
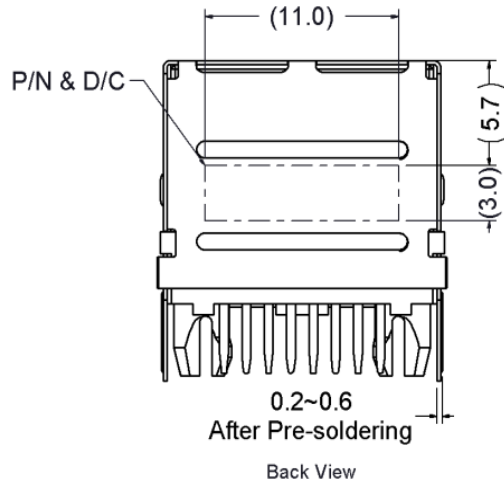
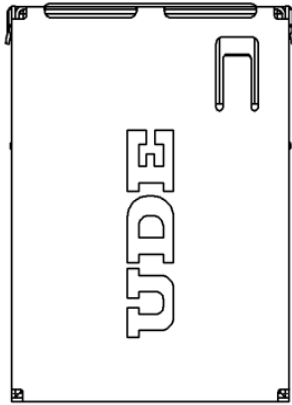

Detail A

Detail B

Recommended PCB Layout. Component side of board

All dimension units are "mm".

All dimension tolerances are ±0.05mm unless otherwise specified.

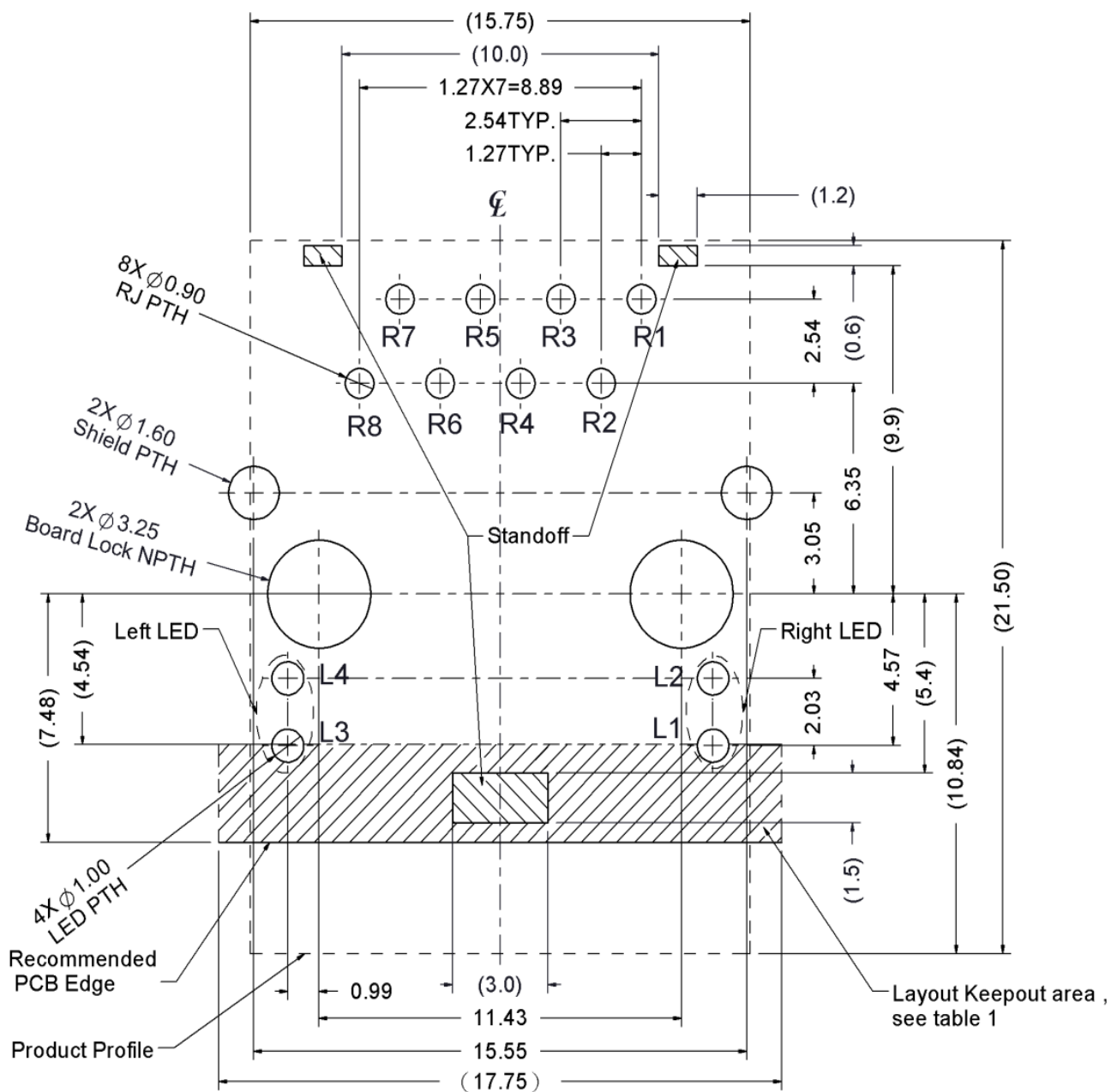
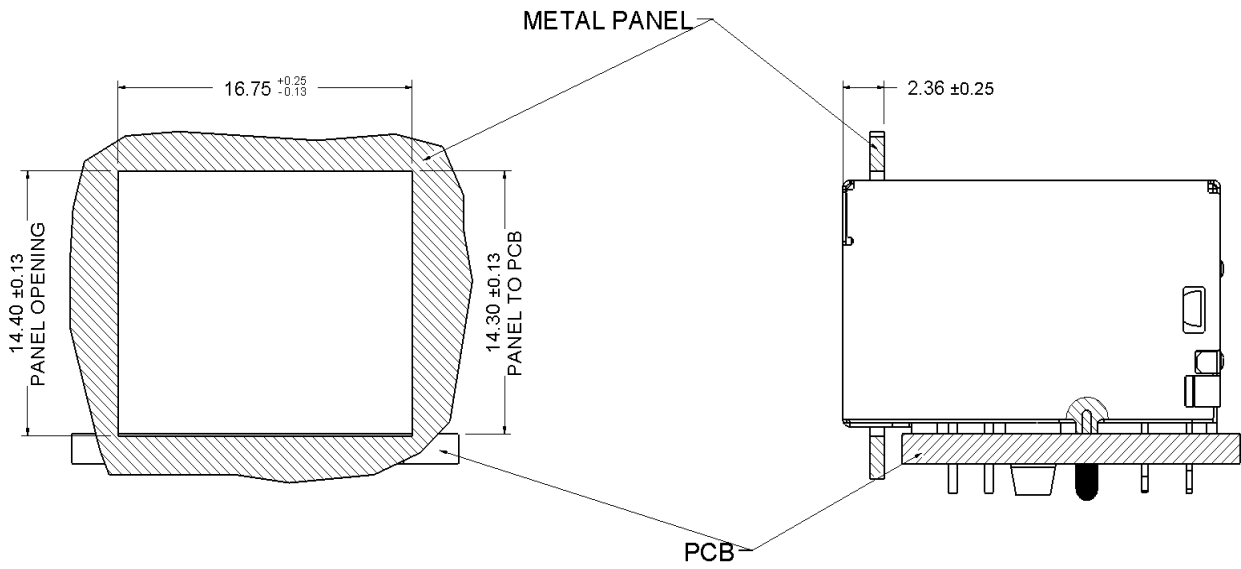

Table1

Layout / Layer	Trace	component	Grounding	Test Point	Via Hole	PTH	NPTH
Component side	X	X	O	X	X	X	O
Inner layer	O	NA	O	NA	O	X	O
Bottom side	O	O	O	O	O	X	O

X--Forbid; O--OK; NA--Not Applicable.

Recommended Panel cutout



2. Packing Information

60 pcs finished goods per tray

7 trays(420 pcs finished goods) per inner box

4 Inner boxes(1680 pcs finished goods) per master carton

### 3. Standard RJ45 Plug Specification

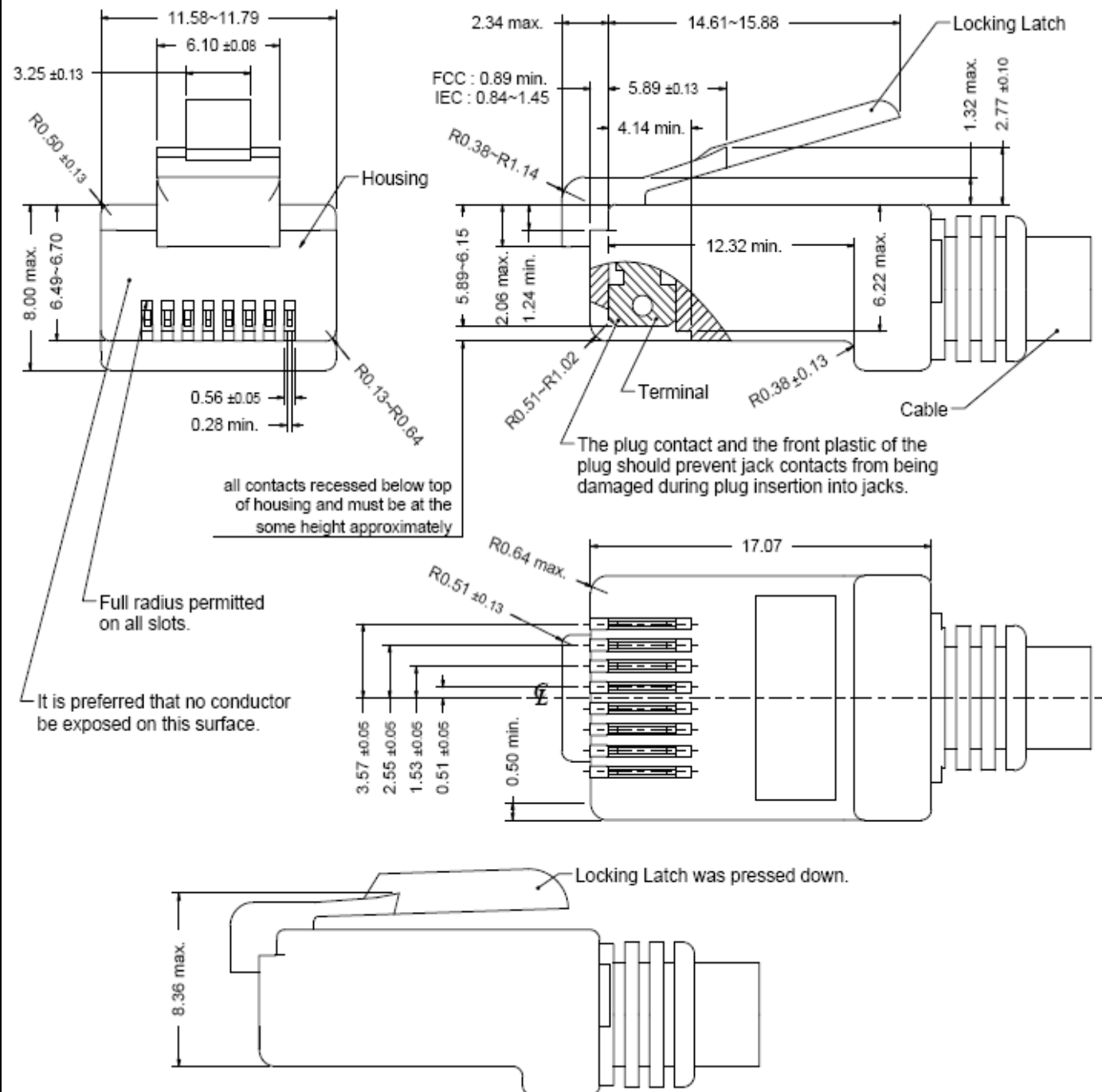

- All dimensions follow :  
 FCC subpart F, 68,500, Figure (C)(2)(i) & (C)(2)(ii) & (C)(3)(i)  
 IEC 60603-7
- All plugs must be meeting the requirements of plug Go & No-Go gauge.  
 Gauge follow : FCC subpart F, 68,500, Figure (C)(4)(i) & (C)(5)(i)
- There must be no damage to Housing and Locking Latch.
- There must be no nicks and cuts in cable.
- Durability : 750 cycles generally

#### 4. REQUIREMENTS

##### Design and Construction

Product shall be of design, construction and physical dimensions specified on applicable.

##### Material

Terminal Parts (Underplating : 50 $\mu$ " min. Nickel overall)

RJ Terminal :Phosphor Bronze, Thickness=0.30mm

Finish : Contact Area : 30 $\mu$ " min.Gold

Input Terminal : Brass, Thickness=0.35mm

Finish : 100 $\mu$ " min. Bright Tin

Case Terminal : Brass, Thickness=0.30mm

Finish : 100 $\mu$ " min. Bright Tin

Plastic Parts <UL94V-0>

Housing : PA6T, Black

Case : PA6T, Nature

Back Cover : PBT, Nature

LED Cover : PBT,Nature

Shield Parts : Stainless steel, Thickness=0.20mm, Pre-soldering

## 5. Operating and Storage Temperature

Operating Temperature : 0°C to +70°C

Storage Temperature : -40°C to +85°C

## 6. RJ45 specifications

Insulation Resistance : 500MΩ min.

Insertion force with the latch depressed : 20N max.

Removal force with the latch depressed : 20N max.

Locking Force of Plug Latch : 50N min. @ 60+/-5 sec.

Durability : 2500 cycles

## 7. Performance and Test Description

Product is designed to meet electrical, mechanical and environmental performance requirements specified in below table.

All tests are performed at ambient environmental conditions per MIL-STD-1344A and EIA-364 unless otherwise specified.

## 8. Packaging and Packing

All parts shall be packaged and packed to protect against physical damage, corrosion and deterioration during shipment and storage.



9. ELECTRICAL CHARACTERISTICS @ 25°C

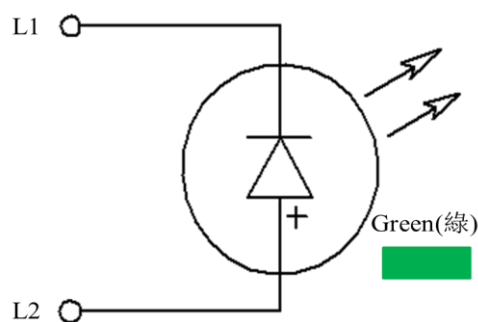
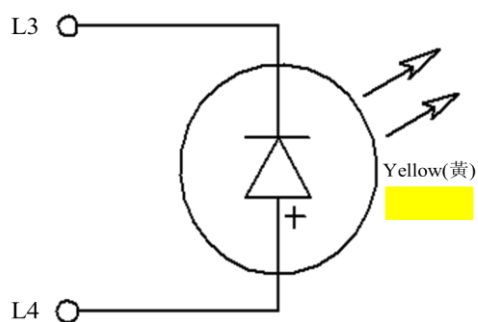
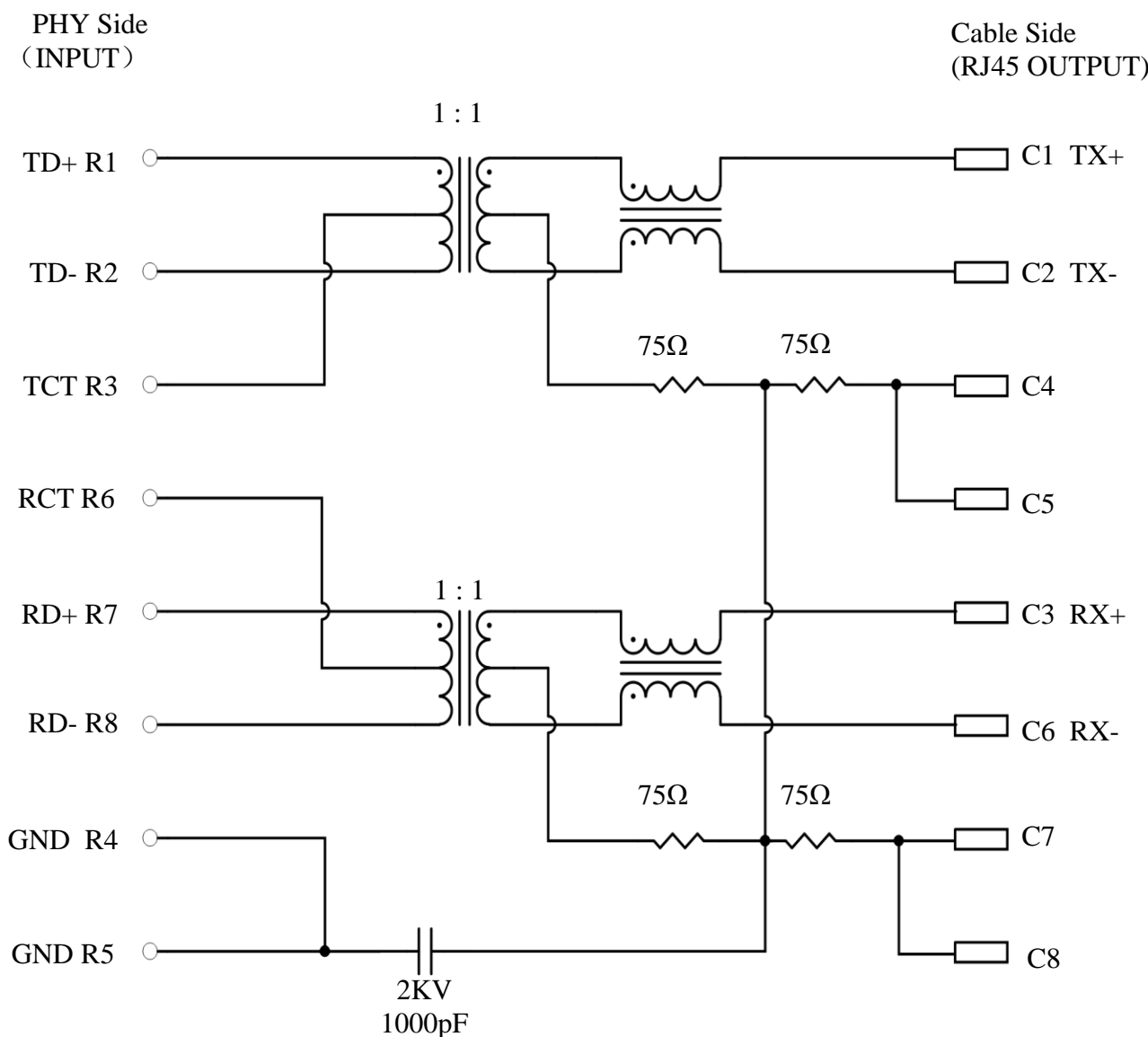

Emitting Color	$\lambda_p$ (nm)	$V_f$ @ $I_f=20mA$	$I_r$ @ $V_r=5V$
Yellow	588	1.7 ~2.6 V	10 $\mu$ A max.
Green	570	1.7 ~2.6 V	10 $\mu$ A max.

## Transmitter filter &amp; Receiver filter

Type : Balance low pass 100Ω impedance

Insertion loss : 1~100MHz -1.0dB Max.

Return loss :	1~30MHz	-18dB Min.	load 100Ω
	30~60MHz	-16dB Min.	load 100Ω
	60~80MHz	-12dB Min.	load 100Ω

## Common Mode Rejection

@1~100 MHz -30dB Min.

## Cross Talk

@ 1~100MHz -30dB Min.

Inductance (OCL) @ 100KHz, 0.1V, 8mA DC BIAS

Input(TD+, TD-); (RD+, RD-) : 350 μH Min.

## HiPot Test

PHY Side(Input) To Cable Side(Output) : 1500Vac 60s or 2250Vdc 60s

### 10. WAVE SOLDERING TEMPERATURE PROFILE

Note :

The measuring point for the specified temperature shall be on the soldered part of the lead.

