



# MXD8921L

SiGe Low Noise Amplifier

with Bypass Mode for LTE Low Band

Rev1.2



This document contains information that is confidential and proprietary to Maxscend Microelectronics Company Limited (Maxscend) and may not be reproduced in any form without express written consent of Maxscend. No transfer or licensing of technology is implied by this document.

### General Description

MXD8921L high gain, low noise amplifier (LNA) is dedicated to LTE low band receive using advanced SiGe process. This product has two operation modes, low noise mode and bypass mode.

MXD8921L works under a 1.6V to 3.6V single power supply while consumes only 3.9 mA current in low noise mode, in bypass mode, the power consumption will be reduced to less than 1uA.

MXD8921L uses a small 1.1mm × 0.7mm × 0.45mm LGA 6-pin package.

### Applications

- LTE low band receiving

### Features

- Broadband frequency range:
  - 600MHz to 1.0GHz
- High Gain
  - 13.5dB gain at 600MHz to 1.0GHz
- Ultra low noise figure
  - 0.65dB NF at 600MHz to 1.0GHz
- Operation current only 3.9mA
- Small, LGA (6-pin, 1.1mm x 0.7mm x 0.45mm) package , MSL1

### Pin Configuration/Application Diagram (Top view)

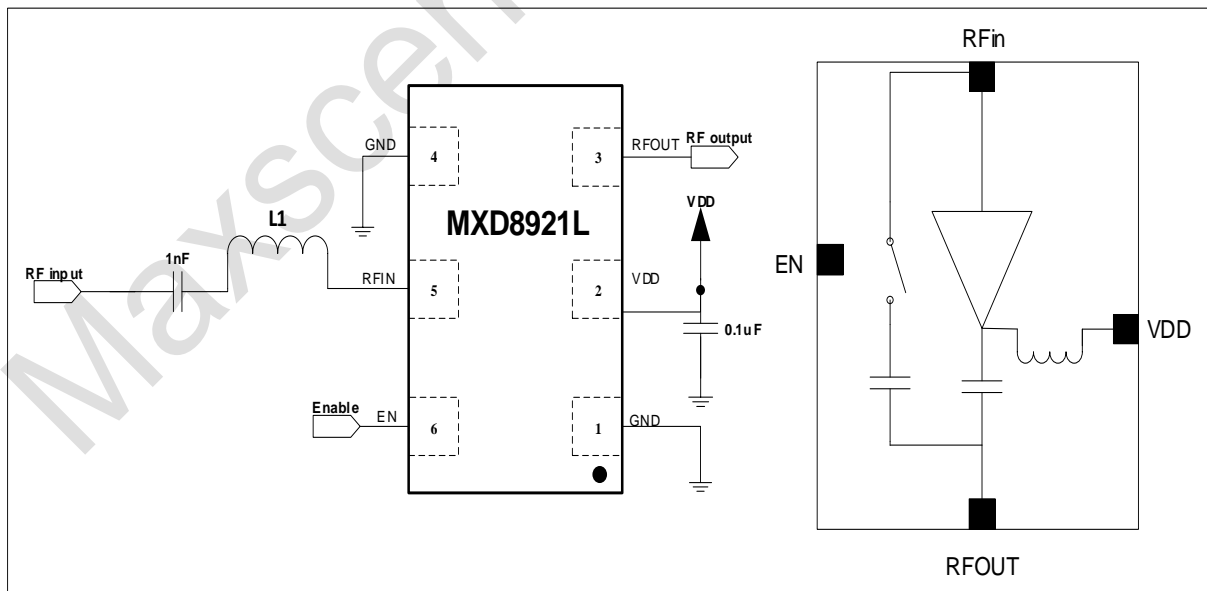

Figure 1 MXD8921L application circuit

## Pin Descriptions & Input matching inductance

**Table 1**

Pin	Pin Name	I/O	Pin Description
1	GND	AG	Analog VSS
2	VDD	AP	Power supply
3	RFOUT	AO	LNA output
4	GND	AG	Analog VSS
5	RFIN	AI	LNA input from antenna
6	EN	DI	Pull high into low noise mode, pull low into bypass mode

**Note:** DI (digital input), DO (digital output), DIO (digital bidirectional), AI (analog input), AO (analog output), AIO (analog bidirectional), AP (analog power), AG (analog ground),

**Table 2 Input matching inductance**

Component	Matching Band	Vendor	Type	Part Number & value
L1	600MHz – 1GHz	Murata	Wired inductor, high Q	LQW15AN, 14nH
		various	Ceramic inductor, low Q	13nH

## Recommended Operation Range

**Table 3**

Parameters	Symbol	Min	Typ	Max	Units
Operation Frequency	f1	600	-	1000	MHz
Power supply	V <sub>DD</sub>	1.6	2.8	3.6	V
Control Voltage High	V <sub>CTL_H</sub>	1.0	1.8	VDD	V
Control Voltage Low	V <sub>CTL_L</sub>	0	0	0.3	V

## Absolute Maximum Ratings

**Table 4 Maximum ratings**

Parameters	Symbol	Minimum	Maximum	Units
Supply voltage	V <sub>DD</sub>	-0.3	+4.0	V
Digital control voltage	V <sub>CTL</sub>	-0.3	VDD+0.3	V
RF input power	P <sub>IN</sub>	-	+25	dBm
Operating temperature	T <sub>OP</sub>	-40	+90	°C
Storage temperature	T <sub>STG</sub>	-65	+160	°C
Electrostatic Discharge Human body model (HBM), Class 1B <sup>Note1</sup>	ESD_HBM	-	2000	V
Charged device model (CDM), Class III <sup>Note2</sup>	ESD_CDM	-	1000	

**Note:** Exposure to maximum rating conditions for extended periods may reduce device reliability. There is no damage to device with only one parameter set at the limit and all other parameters set at or below their nominal value. Exceeding any of the limits listed here may result in permanent damage to the device.

**Note1:** According to ESDA/JEDECJS-001-2014

**Note2:** According to ESDA/JEDECJS-002-2014

**Specifications**

 Typically  $T_A=25^{\circ}\text{C}$   $V_{DD}=2.8\text{V}$ , All data measured on Maxscend's EVB, unless otherwise noted

**Table 5 High Gain mode Electrical Specifications**

Parameter	Symbol	Specification			Units	Test Condition
		Min.	Typical	Max.		
<b>DC Specifications</b>						
Supply voltage	$V_{DD}$	1.6	2.8	3.6	V	
Supply current	$I_{DD}$	2.8	3.9	5.5	mA	$V_{DD} = 2.8\text{V}$ , $V_{EN}=1.8\text{V}$
<b>RF Specifications</b>						
Power gain	G	11.5	13.5	15.5	dB	600M - 1.0GHz
Noise figure	NF	-	0.65	1.2	dB	600M - 1.0GHz
Input Return loss	$ S_{11} $	-	-10	-5	dB	600M - 1.0GHz
Output Return loss	$ S_{22} $	-	-10	-5	dB	600M - 1.0GHz
Stability factor	Kf	1.2	-	-		
Input 1 dB compression point	P1dB	-6	-2.8	-	dBm	at 850MHz
Input IP3	IIP3	5	10	-	dBm	Note1
Switch time	turn-on-time	-	-	6	$\mu\text{s}$	Bypass state to High gain state, to 90% of the Gain
	turn-off-time	-	-	1	$\mu\text{s}$	High Gain state to Bypass state, to 10% of the Gain

 Note1:  $P_{in}=P_{in2}=-20\text{dBm}$ ,  $F1=850\text{MHz}$ ,  $F2=851\text{MHz}$ 
**Table 6 Bypass mode Electrical Specifications**

Parameter	Symbol	Specification			Units	Test Condition
		Min.	Typical	Max.		
<b>DC Specifications</b>						
Supply voltage	$V_{DD}$	1.6	2.8	3.6	V	
Supply current	$I_{DD}$	0	0.1	1	$\mu\text{A}$	$V_{DD} = 2.8\text{V}$ , $V_{EN}=\text{low}$
<b>RF Specifications</b>						
Insertion loss	IL	-7	-3.5	-	dB	600M - 1.0GHz
Input Return loss	$ S_{11} $	-	-10	-5	dB	600M - 1.0GHz
Output Return loss	$ S_{22} $	-	-10	-5	dB	600M - 1.0GHz
Input 1 dB compression point	P1dB	5	10	-	dBm	at 850MHz

## Specifications

Typically  $T_A=25^{\circ}\text{C}$   $V_{DD}=1.8\text{V}$ , All data measured on Maxscend's EVB, unless otherwise noted

**Table 7 High Gain mode Electrical Specifications**

Parameter	Symbol	Specification			Units	Test Condition
		Min.	Typical	Max.		
<b>DC Specifications</b>						
Supply voltage	$V_{DD}$	1.6	1.8	3.6	V	
Supply current	$I_{DD}$	2.6	3.8	5.3	mA	$V_{DD} = 1.8\text{V}$ , $V_{EN}=1.8\text{V}$
<b>RF Specifications</b>						
Power gain	G	11.2	13.2	15.2	dB	600M - 1.0GHz
Noise figure	NF	-	0.65	1.2	dB	600M - 1.0GHz
Input Return loss	$ S_{11} $	-	-10	-5	dB	600M - 1.0GHz
Output Return loss	$ S_{22} $	-	-10	-5	dB	600M - 1.0GHz
Stability factor	Kf	1.2	-	-		
Input 1 dB compression point	P1dB	-8	-4.5	-	dBm	at 850MHz
Input IP3	IIP3	2	7	-	dBm	Note1
Switch time	turn-on-time	-	-	6	$\mu\text{s}$	Bypass state to High gain state, to 90% of the Gain
	turn-off-time	-	-	1	$\mu\text{s}$	High Gain state to Bypass state, to 10% of the Gain

Note1: Pin=Pin2=-20dBm, F1=850MHz, F2=851MHz

**Table 8 Bypass mode Electrical Specifications**

Parameter	Symbol	Specification			Units	Test Condition
		Min.	Typical	Max.		
<b>DC Specifications</b>						
Supply voltage	$V_{DD}$	1.6	1.8	3.6	V	
Supply current	$I_{DD}$	0	0.1	1	$\mu\text{A}$	$V_{DD} = 1.8\text{V}$ , $V_{EN}=\text{low}$
<b>RF Specifications</b>						
Insertion loss	IL	-7.3	-3.8	-	dB	600M - 1.0GHz
Input Return loss	$ S_{11} $	-	-10	-5	dB	600M - 1.0GHz
Output Return loss	$ S_{22} $	-	-10	-5	dB	600M - 1.0GHz
Input 1 dB compression point	P1dB	5	10	-	dBm	at 850MHz

## Package Outline Dimensions

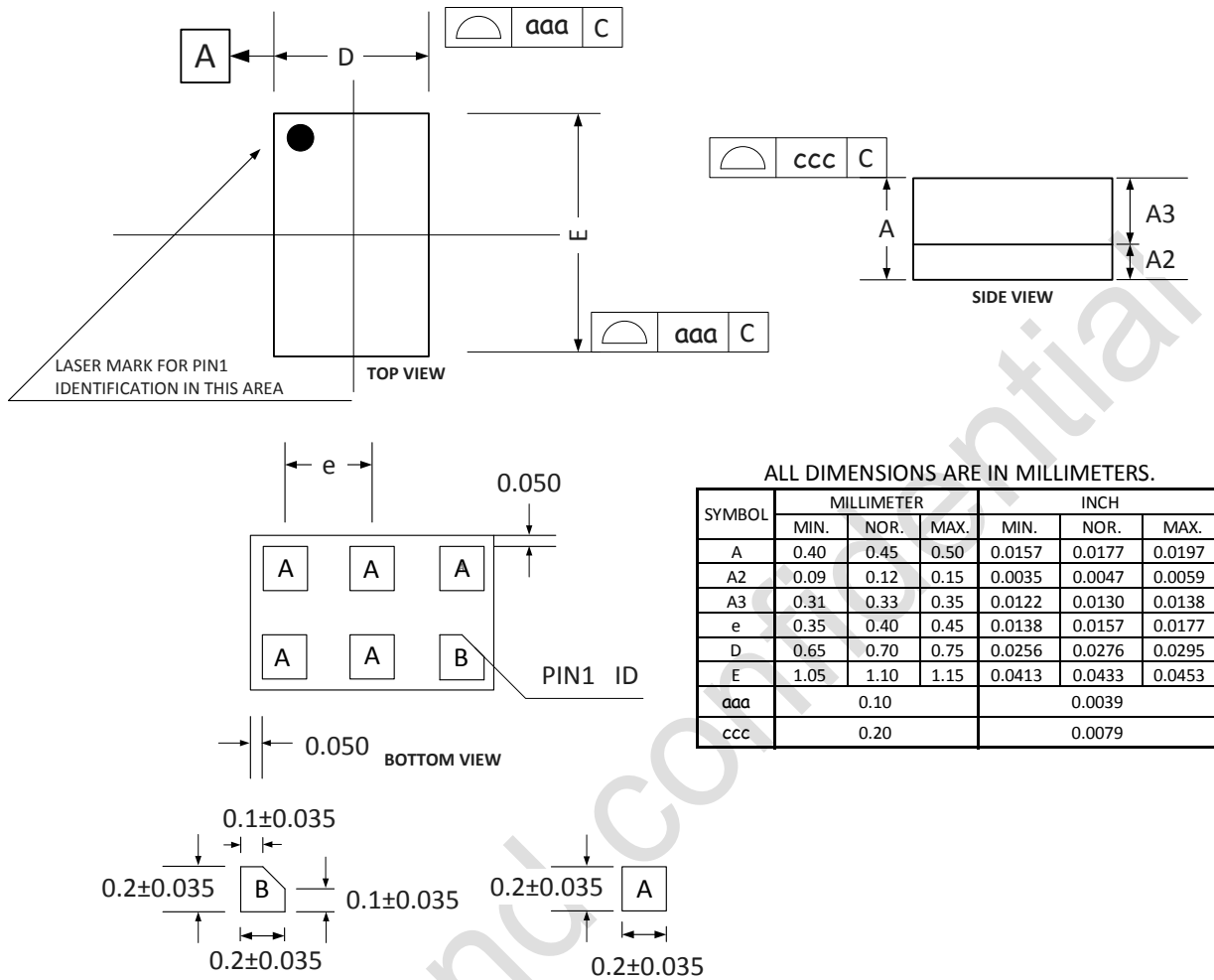

Figure 2 MXD8921L outline dimension

### Marking Specification

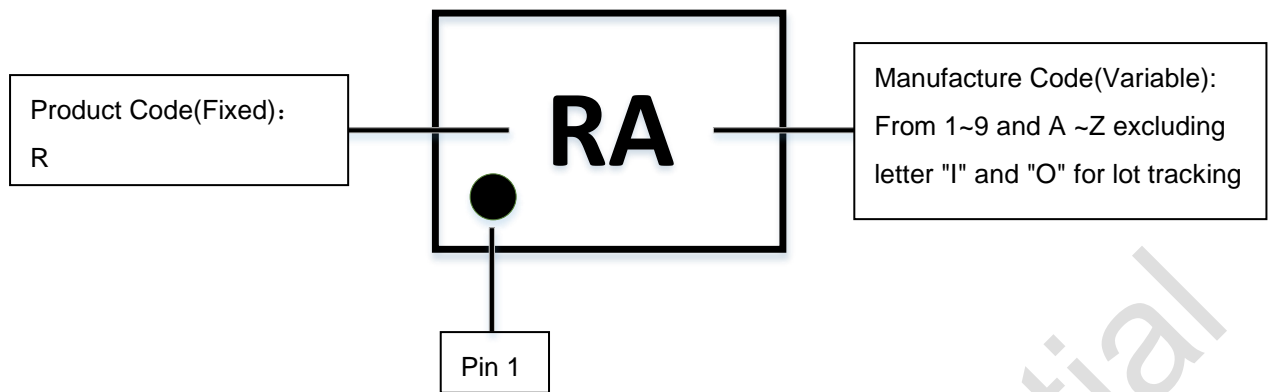

Figure 3 Marking specification (Top View)

### Tape and Reel Dimensions

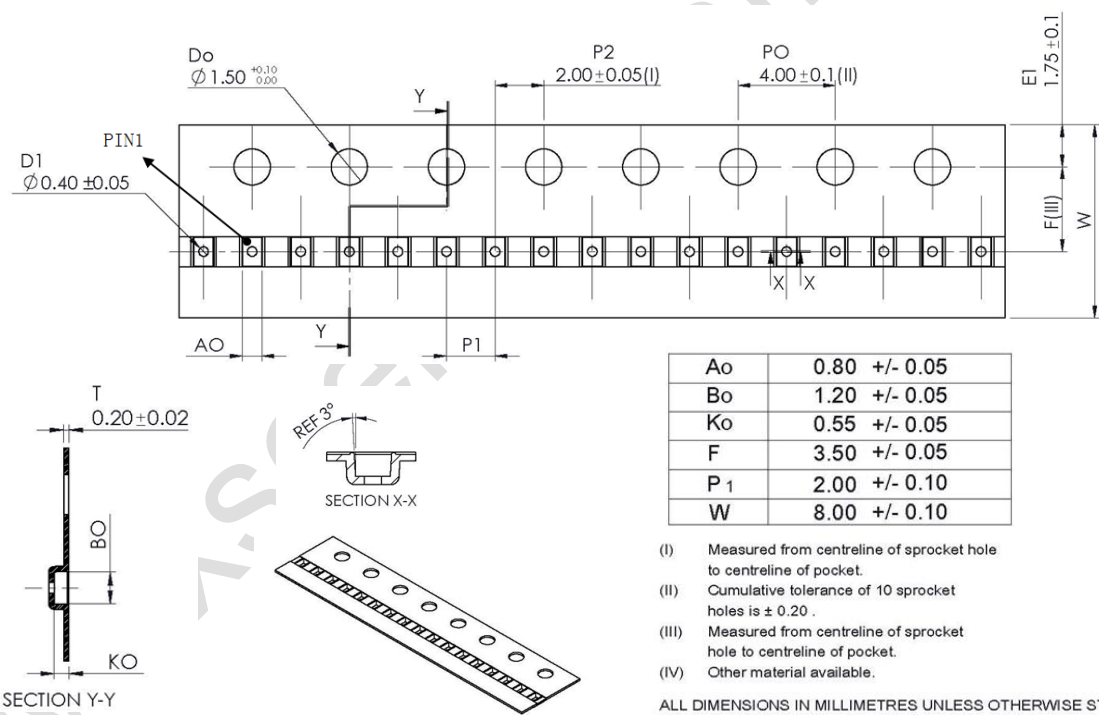

Figure 4 Tape and reel dimensions

**Reflow Chart**

Figure 5 Recommended Lead-Free Reflow Profile

**Table 9 Reflow condition**

Profile Parameter	Lead-Free Assembly, Convection, IR/Convection
Ramp-up rate ( $TS_{max}$ to $T_p$ )	3°C/second max.
Preheat temperature ( $TS_{min}$ to $TS_{max}$ )	150°C to 200°C
Preheat time ( $t_s$ )	60 - 180 seconds
Time above $T_L$ , 217°C ( $t_L$ )	60 - 150 seconds
Peak temperature ( $T_p$ )	260°C
Time within 5°C of peak temperature( $t_p$ )	20 - 40 seconds
Ramp-down rate	6°C/second max.
Time 25°C to peak temperature	8 minutes max.

**ESD Sensitivity**

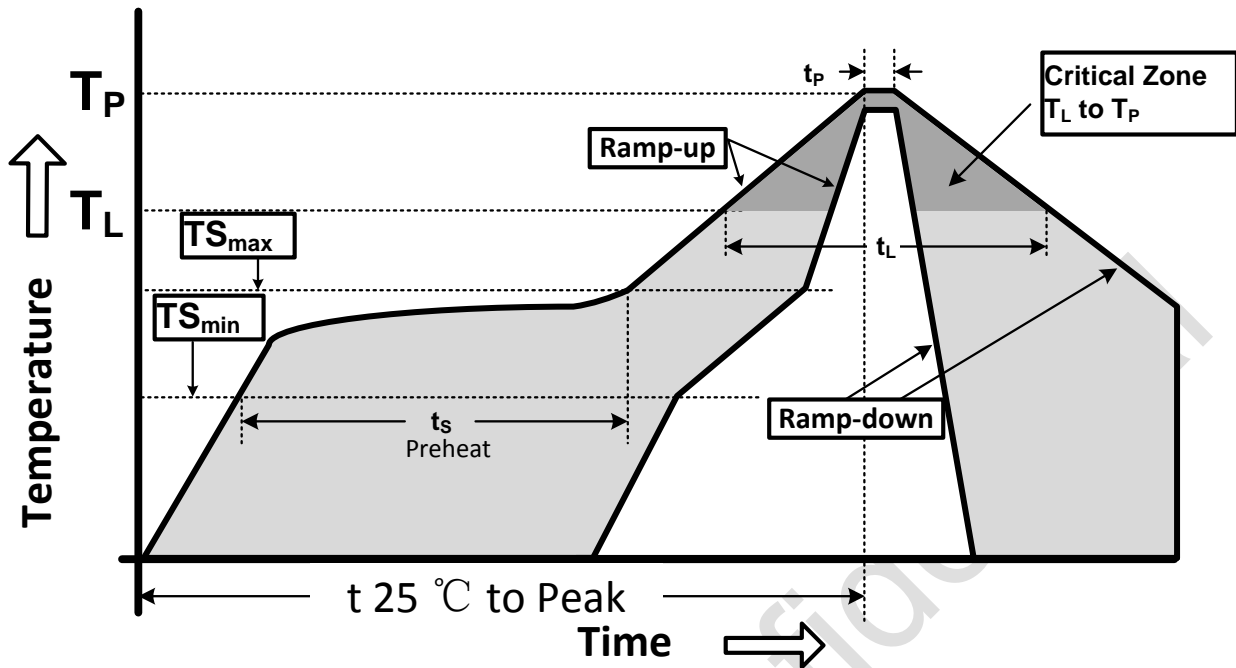
Integrated circuits are ESD sensitive and can be damaged by static electric charge. Proper ESD protection techniques should be used when handling these devices.

**RoHS Compliant**

This product does not contain lead, mercury, cadmium, hexavalent chromium, polybrominated biphenyls (PBB) and polybrominated diphenyl ethers (PBDE), and are considered RoHS compliant.

1.3.1