

APPROVAL SHEET

(RoHS Compliant & Halogen Free)

CUSTOMER : _____
CUSTOMER'S PART NO. : _____
DESCRIPTION : **Multi-layer Chip Balun**
PART NO. : **LTU-0605-2G5S5-A1**
DATE : _____
AUTHORIZED BY : *CF Cheng*

	FULLY APPROVED	PARTIALLY APPROVED	REJECTED
SIGN			
SUGGESTION			

美磊科技股份有限公司

MAG. LAYERS SCIENTIFIC-TECHNICS CO., LTD

HEAD OFFICE / PINGZHEN PLANT

270, Nan-Feng Road, Pingzhen District, Taoyuan City, Taiwan

TEL: 886-3-4159111 FAX: 886-3-4192255

<http://www.maglayers.com.tw>

E-mail : info@maglayers.com.tw

Revision History

Version	Date	Description	Approved by	Prepared by
1	2019/05/29	Initial specification.	CF	CTW



APPLICATION

WLAN, Bluetooth, Home RF, LTE.

FEATURES

- Compact Size**
 Miniaturized SMD packaged in low profile and lightweight.
- Low loss**
 Low insertion loss, high attenuation.
- High Soldering Heat Resistance**
 High quality termination allows both flow and re-flow soldering methods to be applied.
- Characteristics**
 Eliminate noise over a wide frequency range. Idea for high frequency and space limited designs.
- Available in tape and reel packaging for automatic mounting**

PRODUCT IDENTIFICATION

$$\begin{array}{cccccc} \text{L T U} & - & \text{0 6 0 5} & - & \text{\# \# \# x x} & - & \text{A 1} & - & \square \square \\ \text{①} & & \text{②} & & \text{③} & & \text{④} & & \text{⑤} \end{array}$$

- ① Product Code
- ② Dimension Code
- ③ Series Type (### represents center frequency and xx represents material type)
- ④ Design Code
- ⑤ Pattern Code

ELECTRICAL REQUIREMENTS

Part NO.	Frequency	Bandwidth	VSWR	Insertion Loss in BW
LTU-0605-2G5S5-A1	2500 MHz	±200 MHz	2.0 max.	0.7dB max.
	Phase Difference at Balance Port		Amplitude Imbalance at Balance Port	Impedance Unbalance / Balance Port
	180°±10°		2.5 dB max	50 / 100 ohm

PRODUCT DIMENSION

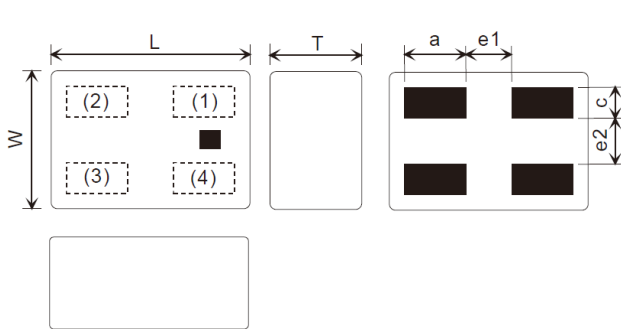

L	W	T	a
0.65±0.1	0.50±0.1	0.4±0.1	0.20±0.05
c	e1	e2	
0.10±0.05	0.20±0.05	0.25±0.05	

NOTE : Dimensions in mm

TERMINAL CONFIGURATION

Top View

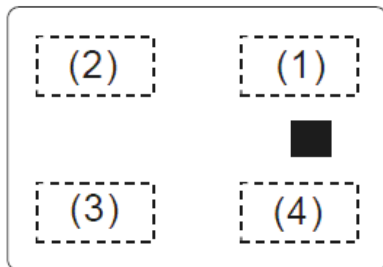

- (1) GND
- (2) Unbalance Port
- (3) Balance Port
- (4) Balance Port

MEASURING DIAGRAM

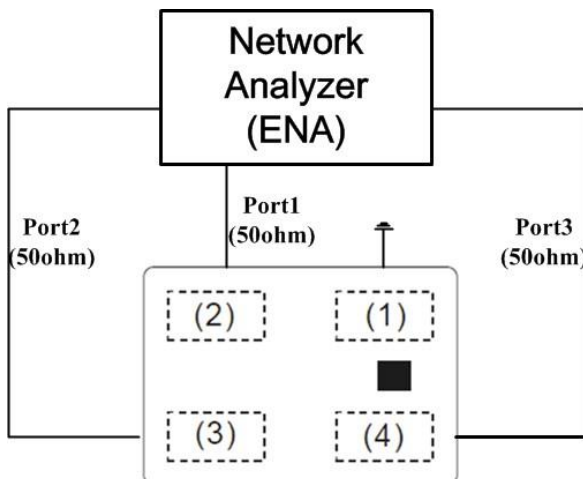

Test Instrument:
Agilent E5071C Network Analyzer

RECOMMENDED PCB LAYOUT AND LAND PATTERN

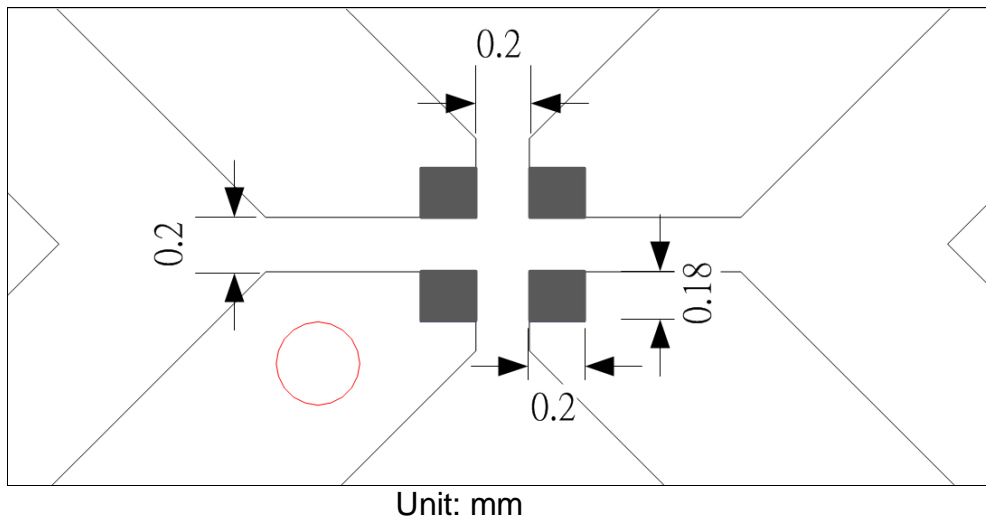

- ⊙ Line width should be designed to match 50Ω characteristic impedance, depending on PCB material and thickness.

ELECTRICAL CHARACTERISTICS (T=25°C)

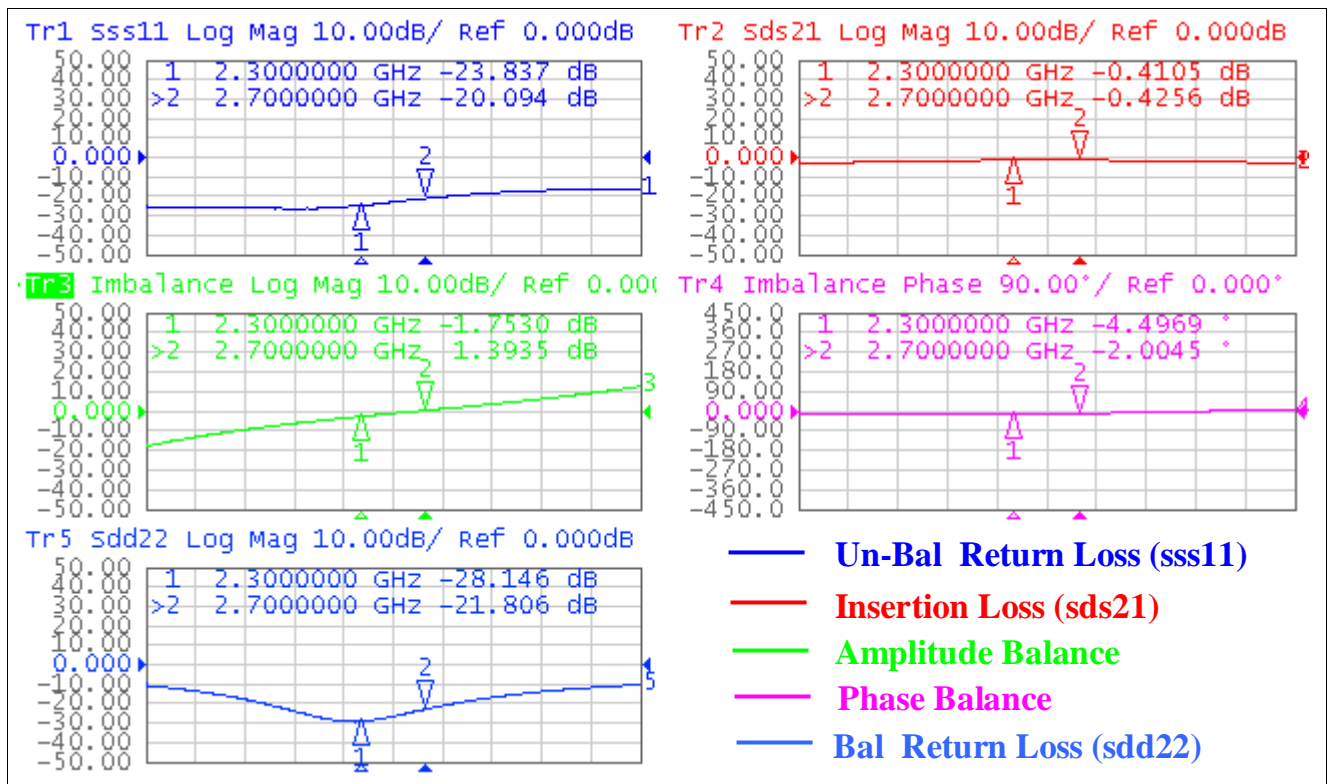

RELIABILITY TEST

Mechanical Test

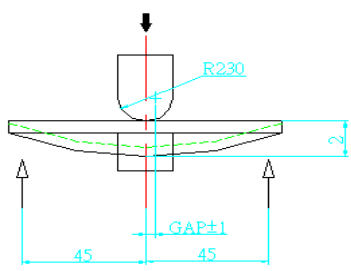
Item	Specification	Test Condition
Vibration	No apparent damage	10 Hz/min~55 Hz/min~10 Hz/min vibration frequency with 1.5 mm amplitude for two hours in x, y, z directions
Drop shock	No apparent damage	Dropped onto printed circuit board from 100cm height three times in x, y, z directions. The terminals shall be protected.
Soldering heat resistance	No apparent damage	Preheating temperature : $150\pm 10^{\circ}\text{C}$ Preheating time : 1 to 2 minutes Solder bath temperature : $260\pm 5^{\circ}\text{C}$ Bathing time : 5 ± 0.5 seconds
Bending test onto printed circuit board	No apparent damage	Solder specimen LTCC components on the test printed circuit board (L: 100 x W: 40 x T: 1.6mm) in appended recommended PCB pattern. Apply the load in direction of the arrow until bending reaches 2 mm. 
Solderability	No apparent damage	The dipped surface of the terminal shall be at least 75% covered with solder after dipped in solder bath of $245\pm 5^{\circ}\text{C}$ for 3 ± 0.5 seconds.

Environment Test

Item	Specification	Test Condition
Thermal shock	No apparent damage Fulfill the electrical spec. after test	$-40^{\circ}\text{C} \sim +85^{\circ}\text{C}$ for 100 cycles each cycle being 30 min
Humidity resistance	No apparent damage Fulfill the electrical spec. after test	$85\pm 2^{\circ}\text{C}$, 80~90% R.H. for 500 hours
High temperature resistance	No apparent damage Fulfill the electrical spec. after test	$+85\pm 2^{\circ}\text{C}$ for 500 hours
Low temperature resistance	No apparent damage Fulfill the electrical spec. after test	$-40\pm 3^{\circ}\text{C}$ for 500 hours

PACKAGING FOR SMC

Peel-off force

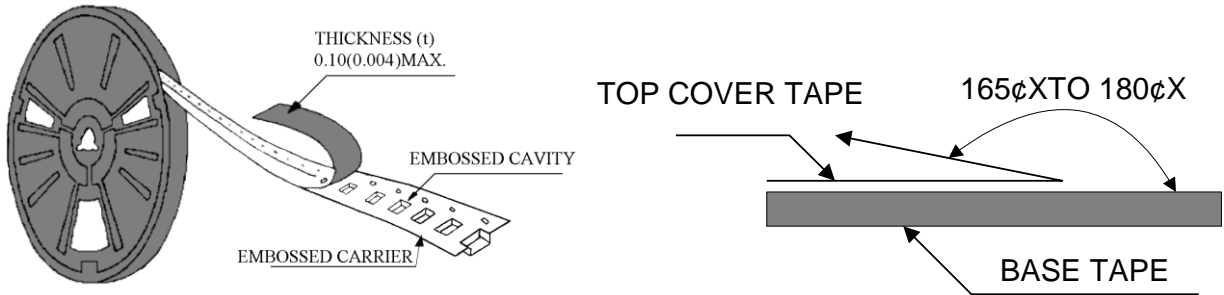

The force for peeling off cover tape is 10 grams in the arrow direction.

Dimension (Unit: mm)

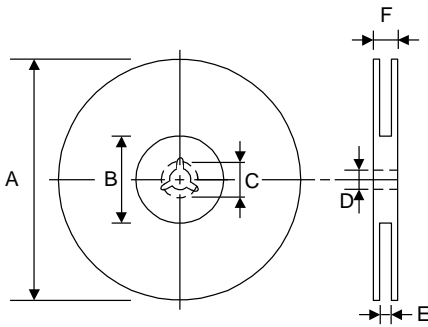

TYPE	A	B	C	D	E	F
8 mm	178±1	60 +0.5 -0	-	13 ±0.2	9 ±0.5	12 ±0.5
12 mm	178±0.3	60 ±0.2	19.3 ±0.1	13.5 ±0.1	13.6 ±0.1	-

Taping quantity

SERIES	5824 5724	5320 5220	4532	4516	3225	3216 2520	2012 1608	1005 0605
PCS/Reel	5000	3000	1000	2000	2500	3000	4000	10000

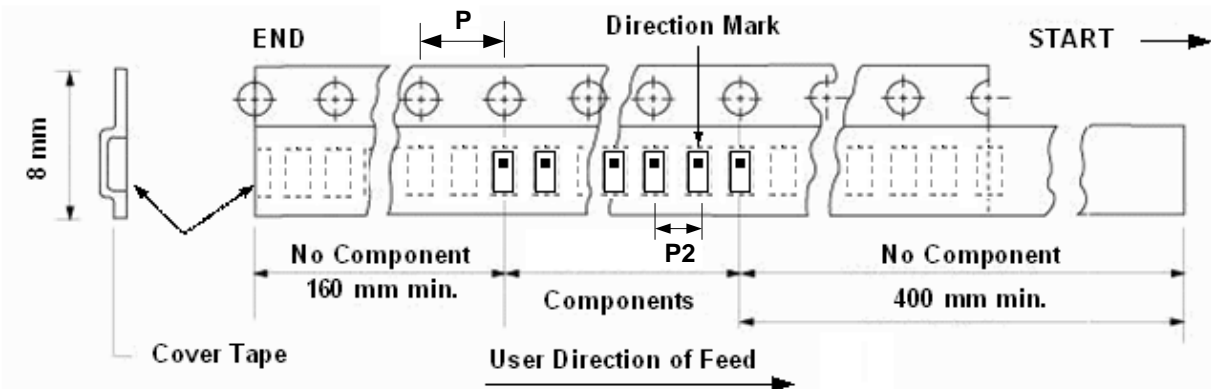

P= 4 mm; P2= 2 mm

TAPE PACKING CASE

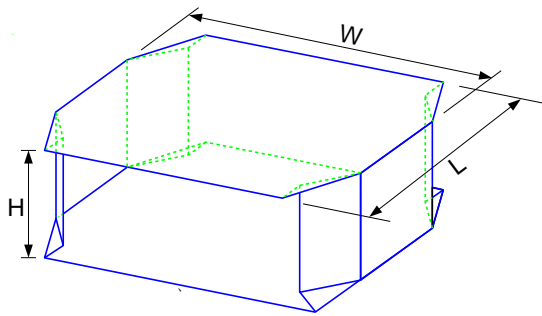

Unit:cm

No. of Reels	W	L	H
2	18±0.5	18±0.5	2.4±0.2
3	18±0.5	18±0.5	3.6±0.2
4	18±0.5	18±0.5	4.8±0.2
5	18±0.5	18±0.5	6.0±0.2

OPERATION TEMPERATURE

-40°C~+85°C

STORAGE CONDITION

The temperature should be within -20 ~ 35°C and humidity should be less than 75% RH. The product should be used within 6 months from the time of delivery.

ATTENTION REGARDING PCB BENDING

- (a) PCB shall be designed so that products are not subjected to the mechanical stress for board warpage. Product shall be located in the sideway direction to the mechanical stress.

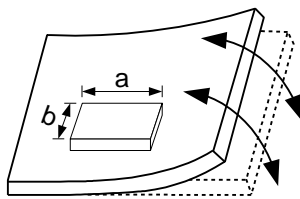

(Poor example)

Length: $a > b$

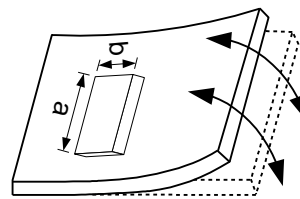

(Good example)

- (b) Products (A,B,C,D) shall be located carefully so that products are not subjected to the mechanical stress due to warping the board. Because they may be subjected to the mechanical stress in order of $A > C > B \approx D$.

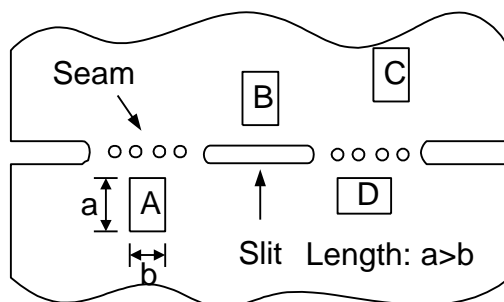

RECOMMENDED REFLOW SOLDERING PROFILE

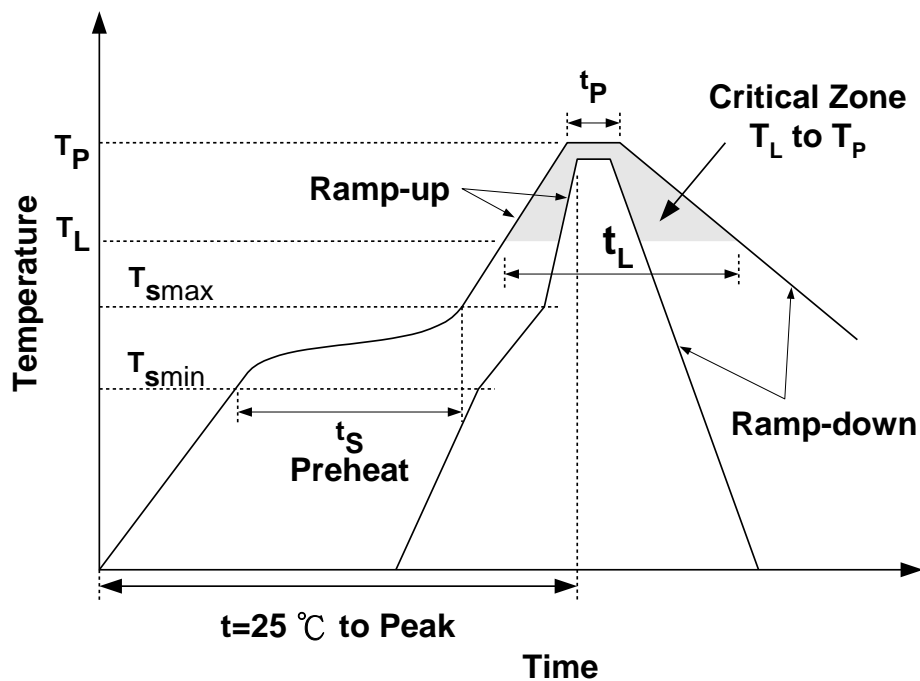

Profile Feature		Sn-Pb	Pb-Free
Preheat	t_s	60~120 seconds	60~180 seconds
	T_{smin}	100°C	150°C
	T_{smax}	150°C	200°C
Average ramp-up rate (T_{smax} to T_P)		3°C/second max.	3°C/second max.
Time main above	Temperature (T_L)	183°C	217°C
	Time (t_L)	60~150 seconds	60~150 seconds
Peak temperature (T_P)		230°C	250~260°C
Time within 5°C of actual peak temperature (t_P)		10 seconds	10 seconds
Ramp-down rate		6°C/sec max.	6°C/sec max.
Time 25°C to peak temperature		6 minutes max.	8 minutes max.

NOTES

The contents of this data sheet are subject to change without notice. Please confirm the specifications and delivery conditions when placing your order.