

DRV8833C Dual H-Bridge Motor Driver

1 Features

- Dual H-Bridge Motor Driver With Current Control
 - 1 or 2 DC Motors or 1 Stepper Motor
 - Low On-Resistance: HS + LS = 1735 mΩ (Typical, 25°C)
- Output Current Capability (at $V_M = 5\text{ V}$, 25°C)
 - PWP (HTSSOP) Package
 - 0.7-A RMS, 1-A Peak per H-Bridge
 - 1.4-A RMS in Parallel Mode
 - RTE (QFN) Package
 - 0.6-A RMS, 1-A Peak per H-Bridge
 - 1.2-A RMS in Parallel Mode
- Wide Power Supply Voltage Range
 - 2.7 to 10.8 V
- Integrated Current Regulation
- Easy Pulse-Width-Modulation (PWM) Interface
- 1.6-μA Low-Current Sleep Mode (at 5 V)
- Small Package and Footprint
 - 16 HTSSOP (PowerPAD™) 5.00 × 6.40 mm
 - 16 QFN (PowerPAD) 3.00 × 3.00 mm
- Protection Features
 - V_M Undervoltage Lockout (UVLO)
 - Overcurrent Protection (OCP)
 - Thermal Shutdown (TSD)
 - Fault Indication Pin (nFAULT)

2 Applications

- Point-of-Sale Printers
- Video Security Cameras
- Office Automation Machines
- Gaming Machines
- Robotics
- Battery-Powered Toys

3 Description

The DRV8833C provides a dual-bridge motor driver solution for toys, printers, and other mechatronic applications.

The device has two H-bridges and can drive two DC brushed motors, a bipolar stepper motor, solenoids, or other inductive loads.

Each H-bridge output consists of a pair of N-channel and P-channel MOSFETs, with circuitry that regulates the winding current. With proper PCB design, each H-bridge of the DRV8833C can drive up to 700-mA RMS (or DC) continuously, at 25°C with a V_M supply of 5 V. The device can support peak currents of up to 1 A per bridge. Current capability is reduced slightly at lower V_M voltages.

Internal shutdown functions with a fault output pin are provided for overcurrent protection, short-circuit protection, UVLO, and overtemperature. A low-power sleep mode is also provided.

Device Information⁽¹⁾

PART NUMBER	PACKAGE	BODY SIZE (NOM)
DRV8833C	HTSSOP (16)	5.00 mm × 6.40 mm
	QFN (16)	3.00 mm × 3.00 mm

(1) For all available packages, see the orderable addendum at the end of the data sheet.

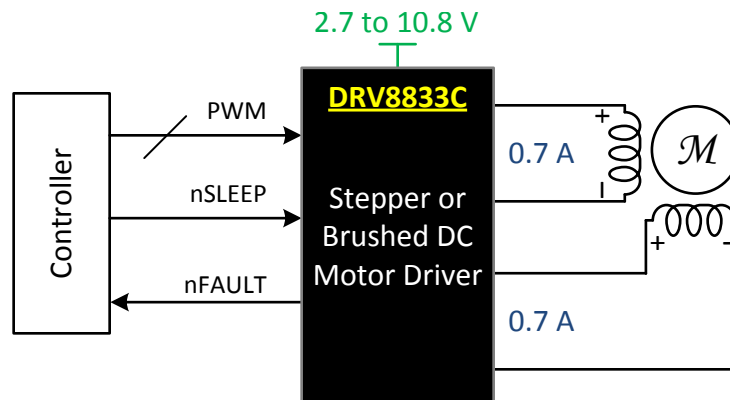

Table of Contents

1 Features	1	7.3 Feature Description	9
2 Applications	1	7.4 Device Functional Modes	13
3 Description	1	8 Application and Implementation	14
4 Revision History	2	8.1 Application Information	14
5 Pin Configuration and Functions	3	8.2 Typical Application	14
6 Specifications	4	9 Power Supply Recommendations	17
6.1 Absolute Maximum Ratings	4	9.1 Sizing Bulk Capacitance for Motor Drive Systems ..	17
6.2 Handling Ratings	4	10 Layout	18
6.3 Recommended Operating Conditions	4	10.1 Layout Guidelines	18
6.4 Thermal Information	5	10.2 Layout Example	18
6.5 Electrical Characteristics	5	11 Device and Documentation Support	19
6.6 Typical Characteristics	7	11.1 Trademarks	19
7 Detailed Description	8	11.2 Electrostatic Discharge Caution	19
7.1 Overview	8	11.3 Glossary	19
7.2 Functional Block Diagram	8	12 Mechanical, Packaging, and Orderable Information	19

4 Revision History

DATE	REVISION	NOTES
August 2014	*	Initial release.

5 Pin Configuration and Functions

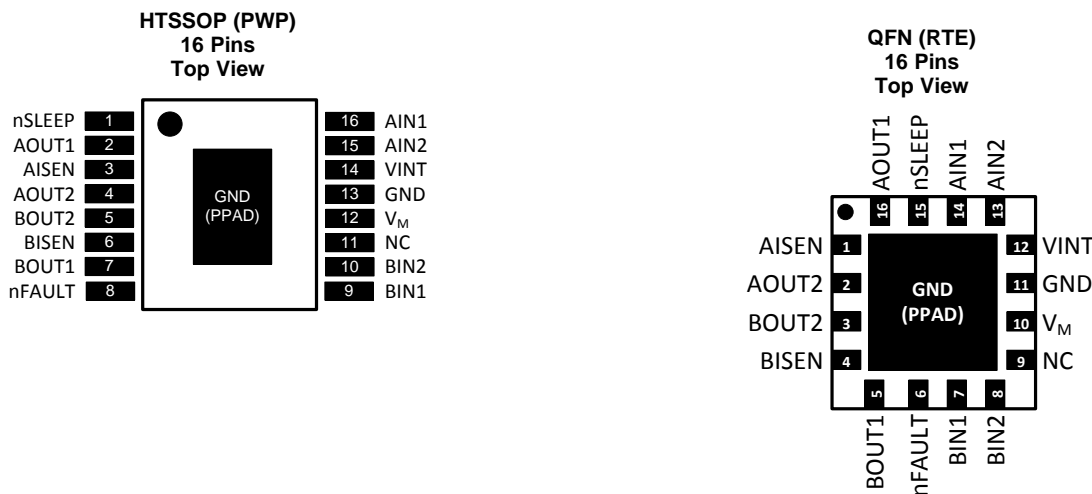

Pin Functions

PIN			TYPE	DESCRIPTION	
NAME	PWP	RTE			
POWER AND GROUND					
GND	13	11	PWR	Device ground	Both the GND pin and device PowerPAD must be connected to ground
VINT	14	12	—	Internal regulator (3.3 V)	Internal supply voltage; bypass to GND with 2.2- μ F, 6.3-V capacitor
V _M	12	10	PWR	Power supply	Connect to motor supply voltage; bypass to GND with a 10- μ F (minimum) capacitor rated for V _M
CONTROL					
AIN1	16	14	I	H-bridge A PWM input	Controls the state of AOUT1 and AOUT2; internal pulldown
AIN2	15	13			
BIN1	9	7	I	H-bridge B PWM input	Controls the state of BOUT1 and BOUT2; internal pulldown
BIN2	10	8			
nSLEEP	1	15	I	Sleep mode input	Logic high to enable device; logic low to enter low-power sleep mode; internal pulldown
STATUS					
nFAULT	8	6	OD	Fault indication pin	Pulled logic low with fault condition; open-drain output requires an external pullup
OUTPUT					
AISEN	3	1	O	Bridge A sense	Sense resistor to GND sets PWM current regulation level (see PWM Motor Drivers)
AOUT1	2	16	O	Bridge A output	Positive current is AOUT1 → AOUT2
AOUT2	4	2			
BISEN	6	4	O	Bridge B sense	Sense resistor to GND sets PWM current regulation level (see PWM Motor Drivers)
BOUT1	7	5	O	Bridge B output	Positive current is BOUT1 → BOUT2
BOUT2	5	3			

External Components

Component	Pin 1	Pin 2	Recommended
C _{VM}	V _M	GND	10-μF ⁽¹⁾ ceramic capacitor rated for V _M
C _{VINT}	VINT	GND	6.3-V, 2.2-μF ceramic capacitor
R _{nFAULT}	VINT ⁽²⁾	nFAULT	>1 kΩ
R _{AISEN}	AISEN	GND	Sense resistor, see Typical Application for sizing
R _{BISEN}	BISEN	GND	Sense resistor, see Typical Application for sizing

- (1) Proper bulk capacitance sizing depends on the motor power.
 (2) nFAULT may be pulled up to an external supply rated < 5.5 V.

6 Specifications

6.1 Absolute Maximum Ratings

over operating free-air temperature (unless otherwise noted) ⁽¹⁾

		MIN	MAX	UNIT
Voltage	Power supply (V _M)	-0.3	11.8	V
	Internal regulator (VINT)	-0.3	3.8	V
	Control pins (AIN1, AIN2, BIN1, BIN2, nSLEEP, nFAULT)	-0.3	7	V
	Continuous phase node pins (AOUT1, AOUT2, BOUT1, BOUT2)	-0.3	V _M + 0.5	V
	Pulsed 10 μs phase node pins (AOUT1, AOUT2, BOUT1, BOUT2)	-1	V _M + 1	V
	Continuous shunt amplifier input pins (AISEN, BISEN)	-0.3	0.5	V
	Pulsed 10 μs shunt amplifier input pins (AISEN, BISEN)	-1	1	V
Peak drive current (AOUT1, AOUT2, BOUT1, BOUT2, AISEN, BISEN)		Internally limited		A
T _J	Operating junction temperature	-40	150	°C

- (1) Stresses beyond those listed under *Absolute Maximum Ratings* may cause permanent damage to the device. These are stress ratings only, which do not imply functional operation of the device at these or any other conditions beyond those indicated under *Recommended Operating Conditions*. Exposure to absolute-maximum-rated conditions for extended periods may affect device reliability.

6.2 Handling Ratings

		MIN	MAX	UNIT	
T _{stg}	Storage temperature range	-65	150	°C	
V _(ESD)	Electrostatic discharge	Human body model (HBM), per ANSI/ESDA/JEDEC JS-001, all pins ⁽¹⁾	-2000	2000	V
		Charged device model (CDM), per JEDEC specification JESD22-C101, all pins ⁽²⁾	-1000	1000	

- (1) JEDEC document JEP155 states that 500-V HBM allows safe manufacturing with a standard ESD control process.
 (2) JEDEC document JEP157 states that 250-V CDM allows safe manufacturing with a standard ESD control process.

6.3 Recommended Operating Conditions

over operating free-air temperature range (unless otherwise noted)

		MIN	MAX	UNIT	
V _M	Power supply voltage range ⁽¹⁾	2.7	10.8	V	
V _I	Logic level input voltage	0	5.5	V	
I _{RMS}	Motor RMS current ⁽²⁾	PWP package	0	0.7	A
		RTE package	0	0.6	A
f _{PWM}	Applied PWM signal to AIN1, AIN2, BIN1, or BIN2	0	200	kHz	
T _A	Operating ambient temperature	-40	85	°C	

- (1) Note that when V_M is below 5 V, R_{DS(ON)} increases and maximum output current is reduced.
 (2) Power dissipation and thermal limits must be observed.

6.4 Thermal Information

THERMAL METRIC ⁽¹⁾		DRV8833C		UNIT
		HTSSOP	QFN	
		16 PINS	16 PINS	
R _{θJA}	Junction-to-ambient thermal resistance	40.5	44.7	°C/W
R _{θJC(top)}	Junction-to-case (top) thermal resistance	32.9	48.5	
R _{θJB}	Junction-to-board thermal resistance	28.8	16.8	
ψ _{JT}	Junction-to-top characterization parameter	0.6	0.7	
ψ _{JB}	Junction-to-board characterization parameter	11.5	16.7	
R _{θJC(bot)}	Junction-to-case (bottom) thermal resistance	4.8	4.2	

(1) For more information about traditional and new thermal metrics, see the *IC Package Thermal Metrics* application report, [SPRA953](#).

6.5 Electrical Characteristics

over operating free-air temperature range (unless otherwise noted)

PARAMETER		TEST CONDITIONS	MIN	TYP	MAX	UNIT
POWER SUPPLIES (V_M, V_{INT})						
V _M	V _M operating voltage		2.7		10.8	V
I _{VM}	V _M operating supply current	V _M = 5 V, xINx low, nSLEEP high		1.7	3	mA
I _{VMQ}	V _M sleep mode supply current	V _M = 5 V, nSLEEP low		1.6	2.7	μA
t _{SLEEP}	Sleep time	nSLEEP low to sleep mode		10		μs
t _{WAKE}	Wake-up time	nSLEEP high to output transition		155		μs
t _{ON}	Turn-on time	V _M > V _{UVLO} to output transition		25		μs
V _{INT}	Internal regulator voltage	V _M = 5 V	3	3.3	3.6	V
CONTROL INPUTS (AIN1, AIN2, BIN1, BIN2, nSLEEP)						
V _{IL}	Input logic low voltage	xINx	0		0.7	V
		nSLEEP	0		0.5	
V _{IH}	Input logic high voltage	xINx	2		5.5	V
		nSLEEP	2.5		5.5	
V _{HYS}	Input logic hysteresis		350	400	650	mV
I _{IL}	Input logic low current	V _{IN} = 0 V	-1		1	μA
I _{IH}	Input logic high current	V _{IN} = 5 V			50	μA
R _{PD}	Pull-down resistance	xINx	100	150	250	kΩ
		nSLEEP	380	500	750	
t _{DEG}	Input deglitch time			575		ns
t _{PROP}	Propagation delay INx to OUTx	V _M = 5 V		1.2		μs
CONTROL OUTPUTS (nFAULT)						
V _{OL}	Output logic low voltage	I _O = 5 mA			0.5	V
I _{OH}	Output logic high leakage	R _{PULLUP} = 1 kΩ to 5 V	-1		1	μA
MOTOR DRIVER OUTPUTS (AOUT1, AOUT2, BOUT1, BOUT2)						
R _{DS(ON)}	High-side FET on-resistance	V _M = 5 V, I = 0.2 A, T _A = 25°C		1180		mΩ
		V _M = 5 V, I = 0.2 A, T _A = 85°C ⁽¹⁾		1400	1475	
		V _M = 2.7 V, I = 0.2 A, T _A = 25°C		1550		
		V _M = 2.7 V, I = 0.2 A, T _A = 85°C ⁽¹⁾		1875	1975	
R _{DS(ON)}	Low-side FET on-resistance	V _M = 5 V, I = 0.2 A, T _A = 25°C		555		mΩ
		V _M = 5 V, I = 0.2 A, T _A = 85°C ⁽¹⁾		675	705	
		V _M = 2.7 V, I = 0.2 A, T _A = 25°C		635		
		V _M = 2.7 V, I = 0.2 A, T _A = 85°C ⁽¹⁾		775	815	

(1) Not tested in production; based on design and characterization data

Electrical Characteristics (continued)

over operating free-air temperature range (unless otherwise noted)

PARAMETER		TEST CONDITIONS	MIN	TYP	MAX	UNIT
I_{OFF}	Off-state leakage current	$V_M = 5\text{ V}$	-1		1	μA
t_{RISE}	Output rise time	$V_M = 5\text{ V}$; $R_L = 16\ \Omega$ to GND		70		ns
t_{FALL}	Output fall time	$V_M = 5\text{ V}$; $R_L = 16\ \Omega$ to V_M		80		ns
t_{DEAD}	Output dead time	Internal dead time		450		ns
PWM CURRENT CONTROL (AISEN, BISEN)						
V_{TRIP}	xISEN trip voltage		160	200	240	mV
t_{OFF}	Current control constant off time	Internal PWM constant off time		20		μs
PROTECTION CIRCUITS						
V_{UVLO}	V_M undervoltage lockout	V_M falling; UVLO report			2.6	V
		V_M rising; UVLO recovery			2.7	
$V_{UVLO,HYS}$	V_M undervoltage hysteresis	Rising to falling threshold		90		mV
I_{OCP}	Overcurrent protection trip level		1			A
t_{DEG}	Overcurrent deglitch time			2.3		μs
t_{OCP}	Overcurrent protection period			1.4		ms
$T_{TSD}^{(2)}$	Thermal shutdown temperature	Die temperature, T_J	150			$^{\circ}\text{C}$
T_{HYS}	Thermal shutdown hysteresis	Die temperature, T_J		20		$^{\circ}\text{C}$

(2) Not tested in production; based on design and characterization data

6.6 Typical Characteristics

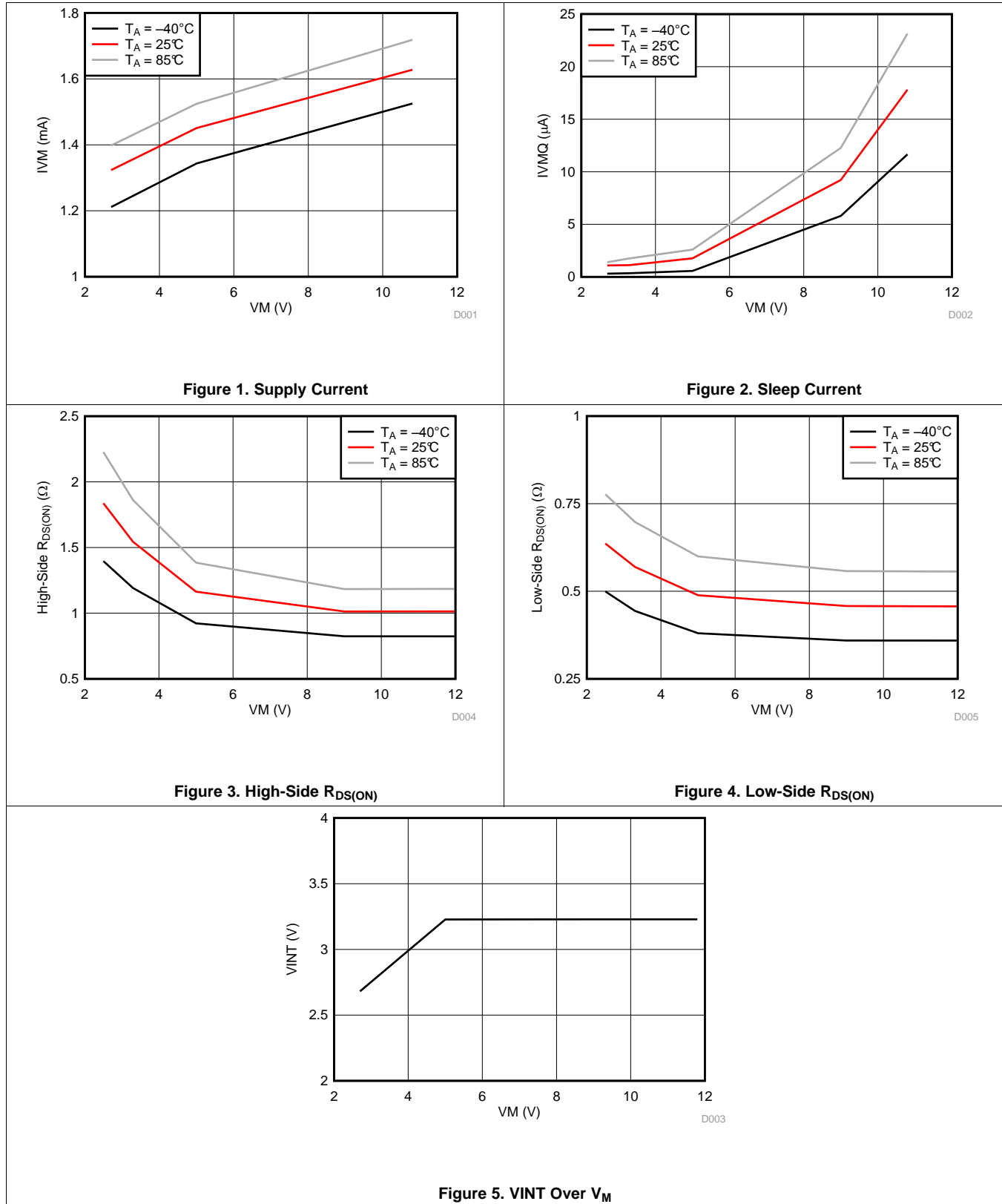

7 Detailed Description

7.1 Overview

The DRV8833C device is an integrated motor driver solution for brushed DC or bipolar stepper motors. The device integrates two PMOS + NMOS H-bridges and current regulation circuitry. The DRV8833C can be powered with a supply voltage from 2.7 to 10.8 V and can provide an output current up to 700 mA RMS.

A simple PWM interface allows easy interfacing to the controller circuit.

The current regulation is a 20- μ s fixed off-time slow decay.

The device includes a low-power sleep mode, which lets the system save power when not driving the motor.

7.2 Functional Block Diagram

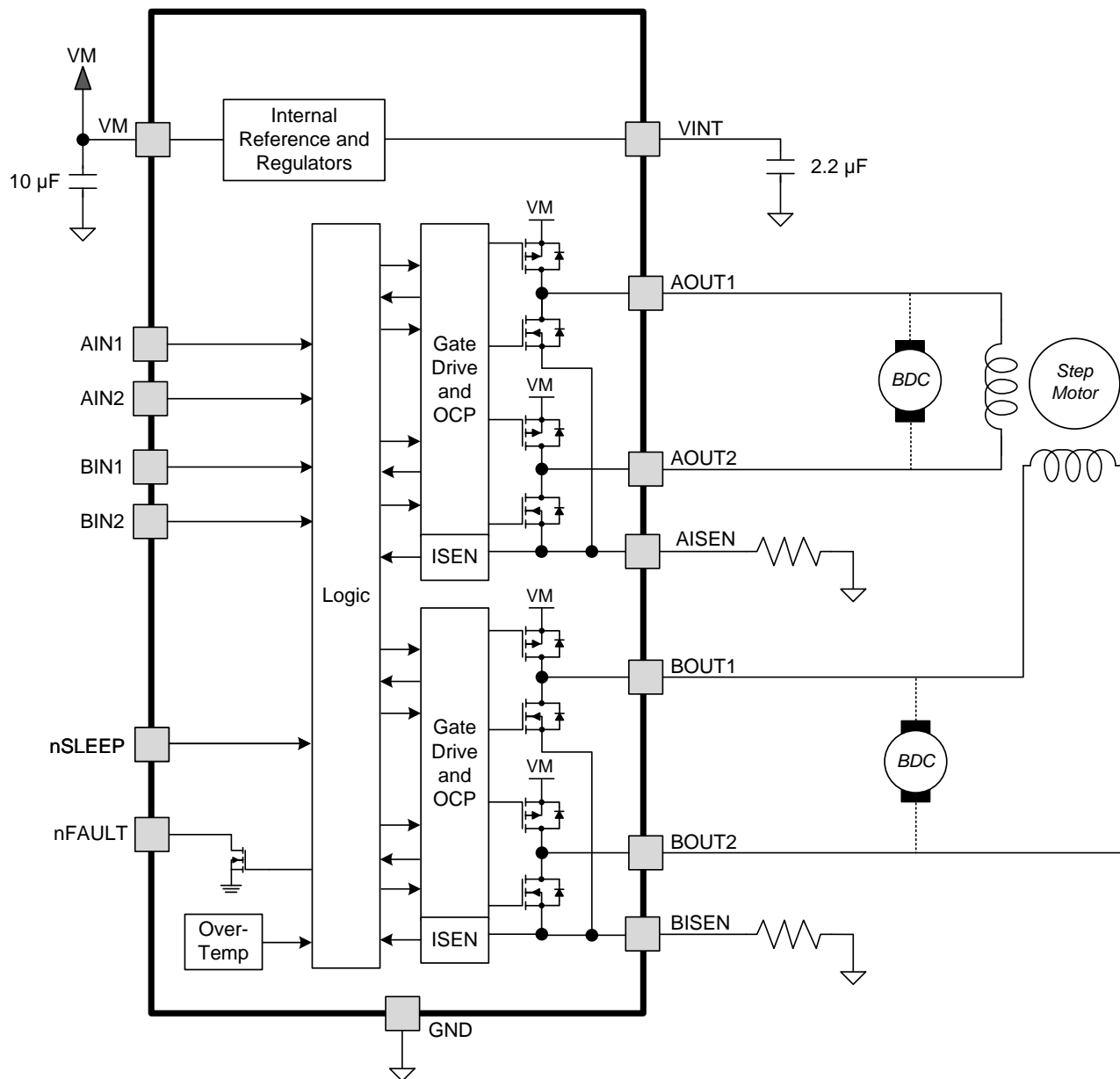

7.3 Feature Description

7.3.1 PWM Motor Drivers

The DRV8833C contains drivers for two full H-bridges. Figure 6 shows a block diagram of the circuitry.

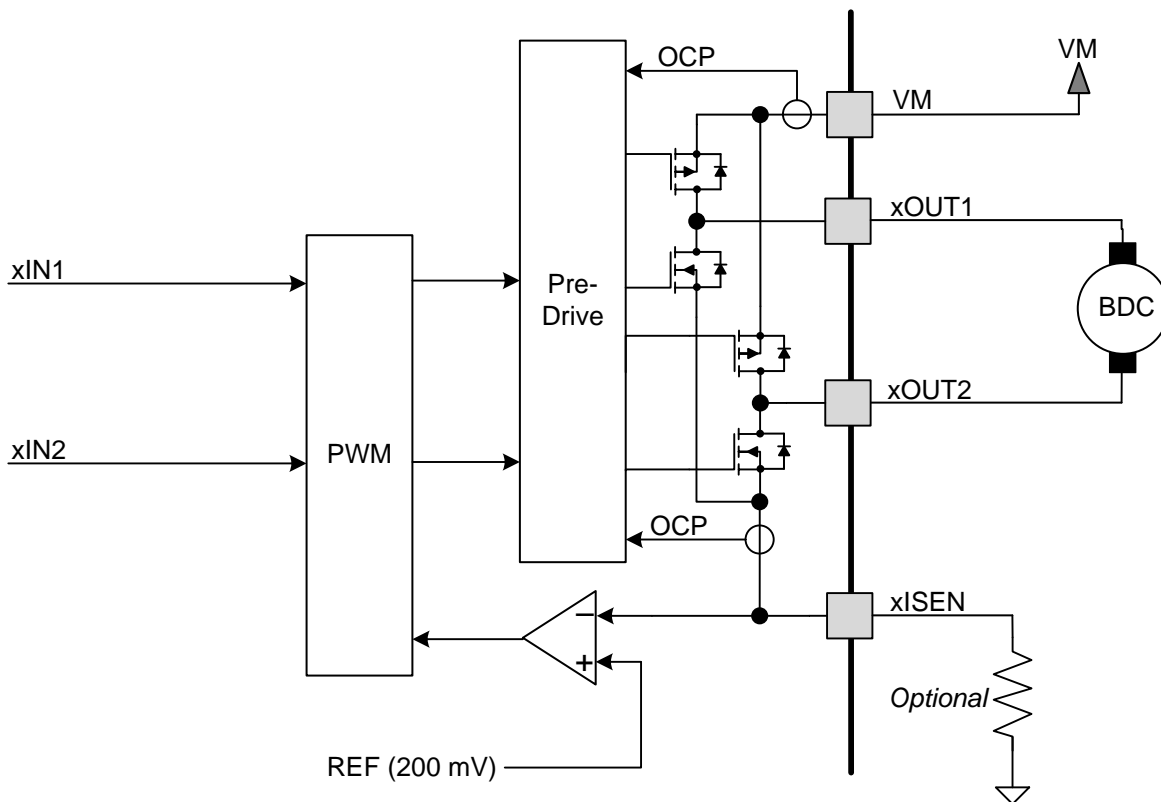

Figure 6. H-Bridge and Current-Chopping Circuitry

7.3.2 Bridge Control and Decay Modes

The AIN1 and AIN2 input pins control the state of the AOUT1 and AOUT2 outputs; similarly, the BIN1 and BIN2 input pins control the state of the BOUT1 and BOUT2 outputs (see Table 1).

Table 1. H-Bridge Logic

xIN1	xIN2	xOUT1	xOUT2	FUNCTION
0	0	Z	Z	Coast / fast decay
0	1	L	H	Reverse
1	0	H	L	Forward
1	1	L	L	Brake / slow decay

The inputs can also be used for PWM control of the motor speed. When controlling a winding with PWM and the drive current is interrupted, the inductive nature of the motor requires that the current must continue to flow (called recirculation current). To handle this recirculation current, the H-bridge can operate in two different states, fast decay or slow decay. In fast-decay mode, the H-bridge is disabled and recirculation current flows through the body diodes. In slow-decay mode, the motor winding is shorted by enabling both low-side FETs.

To externally pulse-width modulate the bridge in fast-decay mode, the PWM signal is applied to one xIN pin while the other is held low; to use slow-decay mode, one xIN pin is held high. See Table 2 for more information.

Table 2. PWM Control of Motor Speed

xIN1	xIN2	FUNCTION
PWM	0	Forward PWM, fast decay
1	PWM	Forward PWM, slow decay
0	PWM	Reverse PWM, fast decay
PWM	1	Reverse PWM, slow decay

The internal current control is still enabled when applying external PWM to xIN. To disable the current control when applying external PWM, the xISEN pins should be connected directly to ground. Figure 7 show the current paths in different drive and decay modes.

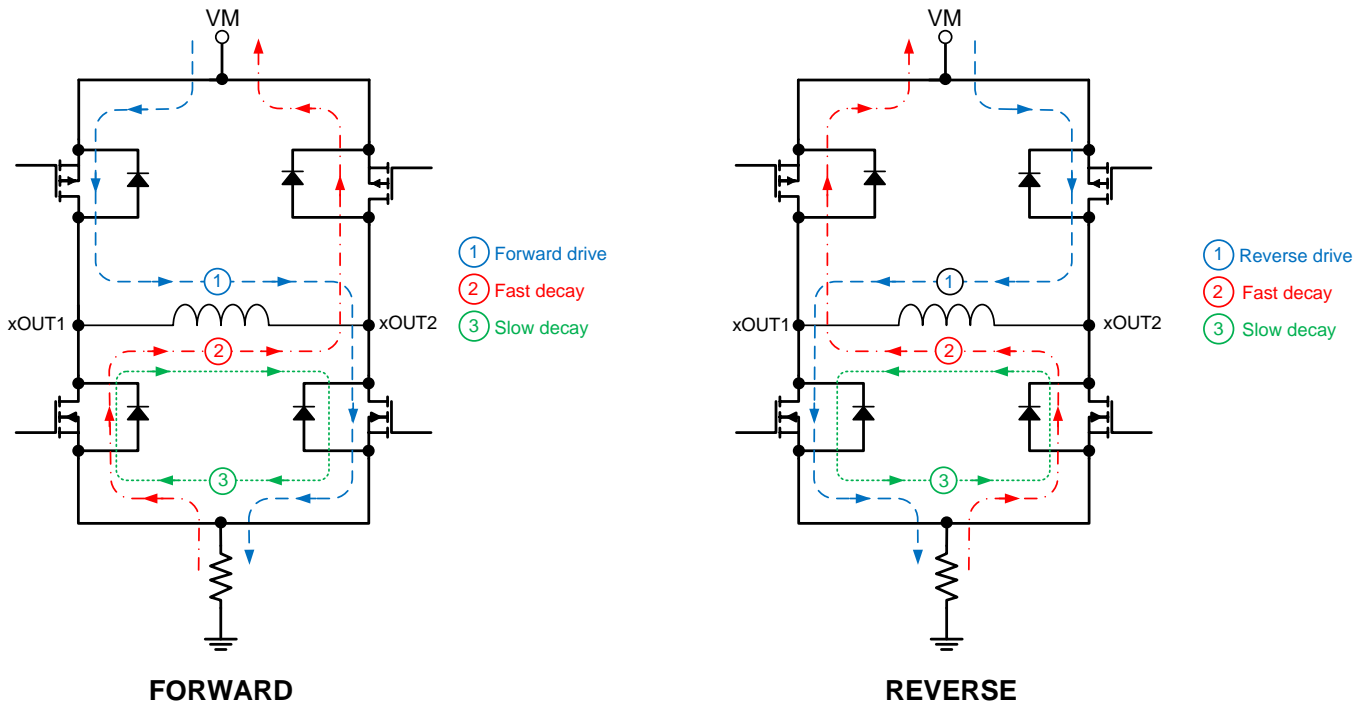

Figure 7. Drive and Decay Modes

7.3.3 Current Control

The current through the motor windings may be limited, or controlled, by a 20-μs constant off-time PWM current regulation, or current chopping. For DC motors, current control is used to limit the start-up and stall current of the motor. For stepper motors, current control is often used at all times.

When an H-bridge is enabled, current rises through the winding at a rate dependent on the DC voltage and inductance of the winding. If the current reaches the current chopping threshold, the bridge disables the current until the beginning of the next PWM cycle. Note that immediately after the output is enabled, the voltage on the xISEN pin is ignored for a fixed period of time before enabling the current sense circuitry. This blanking time is fixed at 3.75 μs.

The PWM chopping current is set by a comparator that compares the voltage across a current sense resistor connected to the xISEN pins with a reference voltage. The reference voltage, V_{TRIP}, is fixed at 200 mV nominally.

The chopping current is calculated as in Equation 1.

$$I_{CHOP} = \frac{200 \text{ mV}}{R_{XISEN}} \tag{1}$$

Example: If a 1-Ω sense resistor is used, the chopping current will be 200 mV / 1 Ω = 200 mA.

NOTE

If current control is not needed, the xISEN pins should be connected directly to ground.

7.3.4 Decay Mode

After the chopping current threshold is reached, the H-bridge switches to slow-decay mode. This state is held for t_{off} (20 μ s) until the next cycle to turn on the high-side MOSFETs.

7.3.5 Slow Decay

In slow-decay mode, the high-side MOSFETs are turned off and both of the low-side MOSFETs are turned on. The motor current decreases while flowing in the two low-side MOSFETs until reaching its fixed off time (typically 20 μ s). After that, the high-side MOSFETs are enabled to increase the winding current again.

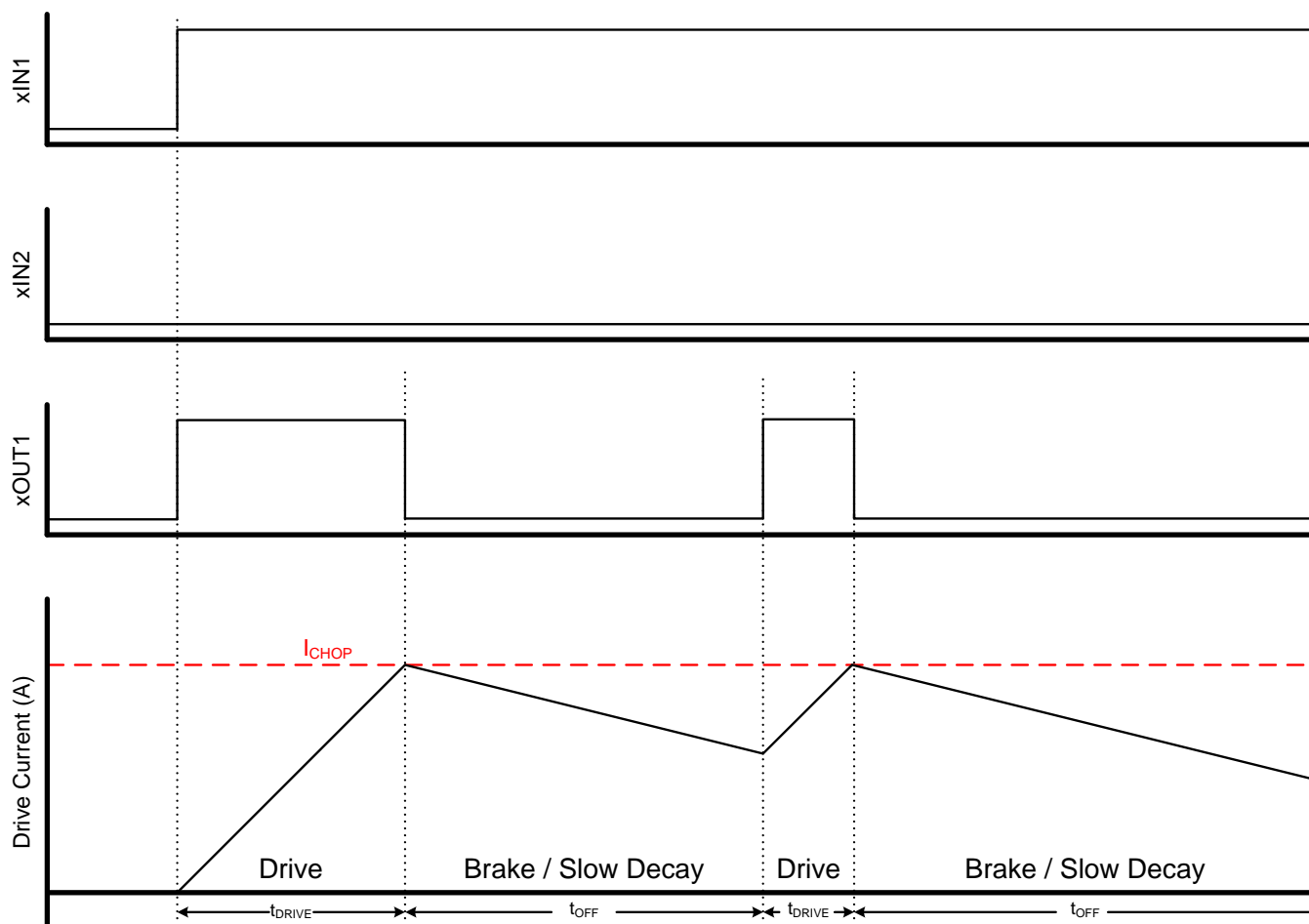

Figure 8. Current Chopping Operation

7.3.6 Sleep Mode

Driving nSLEEP low puts the device into a low-power sleep state. In this state, the H-bridges are disabled, all internal logic is reset, and all internal clocks are stopped. All inputs are ignored until nSLEEP returns inactive high. When returning from sleep mode, some time, t_{WAKE} , needs to pass before the motor driver becomes fully operational. To make the board design simple, the nSLEEP can be pulled up to the supply (V_M). TI recommends to use a pullup resistor when this is done. This resistor limits the current to the input in case V_M is higher than 6.5 V. Internally, the nSLEEP pin has a 500-k Ω resistor to GND. It also has a clamping Zener diode that clamps the voltage at the pin at 6.5 V. Currents greater than 250 μ A can cause damage to the input structure. Therefore, TI recommends a pullup resistor between 20 to 75 k Ω .

7.3.7 Parallel Mode

The two H-bridges in the DRV8833C can be connected in parallel for double the current of a single H-bridge. The internal dead time in the DRV8833C prevents any risk of cross-conduction (shoot-through) between the two bridges due to timing differences between the two bridges. Figure 9 shows the connections.

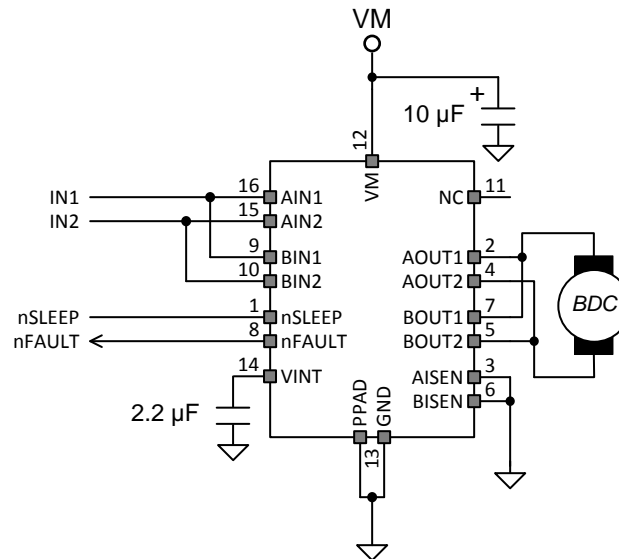

Figure 9. Parallel Mode Schematic

7.3.8 Protection Circuits

The DRV8833C is fully protected against overcurrent, overtemperature, and undervoltage events.

7.3.8.1 Overcurrent Protection (OCP)

An analog current limit (I_{OCP}) circuit on each FET limits the current through the FET by limiting the gate drive. If this analog current limit persists for longer than the OCP deglitch time (t_{DEG}), all FETs in the H-bridge are disabled and the nFAULT pin is driven low. The driver is re-enabled after the OCP retry period (t_{OCP}) has passed. nFAULT becomes high again after the retry time. If the fault condition is still present, the cycle repeats. If the fault is no longer present, normal operation resumes and nFAULT remains deasserted. Note that only the H-bridge in which the OCP is detected will be disabled while the other bridge functions normally.

Overcurrent conditions are detected independently on both high-side and low-side devices; a short to ground, supply, or across the motor winding all result in an overcurrent shutdown. Note that overcurrent protection does not use the current sense circuitry used for PWM current control, so it functions even without presence of the xISEN resistors.

7.3.8.2 Thermal Shutdown (TSD)

If the die temperature exceeds safe limits, all FETs in the H-bridge are disabled and the nFAULT pin is driven low. After the die temperature has fallen below the specified hysteresis (T_{HYS}), operation automatically resumes. The nFAULT pin is released after operation has resumed.

7.3.8.3 UVLO

If at any time the voltage on the V_M pin falls below the UVLO threshold voltage, V_{UVLO} , all circuitry in the device is disabled, and all internal logic is reset. Operation resumes when V_M rises above the UVLO threshold. The nFAULT pin is not driven low during an undervoltage condition.

Table 3. Device Protection

Fault	Condition	Error Report	H-Bridge	Internal Circuits	Recovery
V_M undervoltage (UVLO)	$V_M < 2.6\text{ V}$	None	Disabled	Disabled	$V_M > 2.7\text{ V}$
Overcurrent (OCP)	$I_{OUT} > I_{OCP}$	FAULTn	Disabled	Operating	OCP
Thermal Shutdown (TSD)	$T_J > T_{TSD}$	FAULTn	Disabled	Operating	$T_J < T_{TSD} - T_{HYS}$

7.4 Device Functional Modes

The DRV8833C is active unless the nSLEEP pin is brought logic low. In sleep mode, the H-bridge FETs are disabled (Hi-Z). Note that t_{SLEEP} must elapse after a falling edge on the nSLEEP pin before the device is in sleep mode. The DRV8833C is brought out of sleep mode automatically if nSLEEP is brought logic high. Note that t_{WAKE} must elapse before the outputs change state after wake-up.

Table 4. Modes of Operation

Fault	Condition	H-Bridge	Internal Circuits
Operating	nSLEEP pin high	Operating	Operating
Sleep mode	nSLEEP pin low	Disabled	Disabled
Fault encountered	Any fault condition met	Disabled	See Table 3

8 Application and Implementation

8.1 Application Information

The DRV8833C is used in stepper or brushed DC motor control. The following design procedure can be used to configure the DRV8833C in a bipolar stepper motor application.

8.2 Typical Application

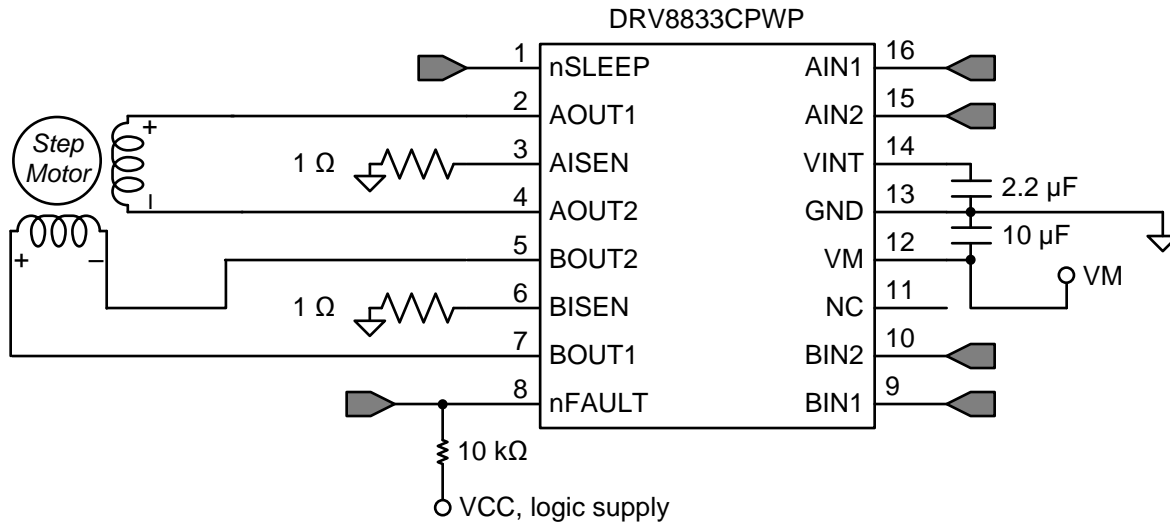

8.2.1 Design Requirements

Table 5 gives design input parameters for system design.

Table 5. Design Parameters

Design Parameter	Reference	Example Value
Supply voltage	V_M	9 V
Motor winding resistance	R_L	12 Ω /phase
Motor winding inductance	L_L	10 mH/phase
Motor full step angle	θ_{step}	1.8 $^\circ$ /step
Target stepping level	n_m	2 (half-stepping)
Target motor speed	v	120 rpm
Target chopping current	I_{CHOP}	200 mA
Sense resistor	R_{ISEN}	1 Ω

8.2.2 Detailed Design Procedure

8.2.2.1 Stepper Motor Speed

The first step in configuring the DRV8833C requires the desired motor speed and stepping level. The DRV8833C can support full- and half-stepping modes using the PWM interface.

If the target motor speed is too high, the motor does not spin. Ensure that the motor can support the target speed.

For a desired motor speed (v), microstepping level (n_m), and motor full step angle (θ_{step}),

$$f_{\text{step}} (\text{steps / s}) = \frac{v(\text{rpm}) \times n_m (\text{steps}) \times 360^\circ / \text{rot}}{\theta_{\text{step}} (^\circ / \text{step}) \times 60 \text{ s / min}} \quad (2)$$

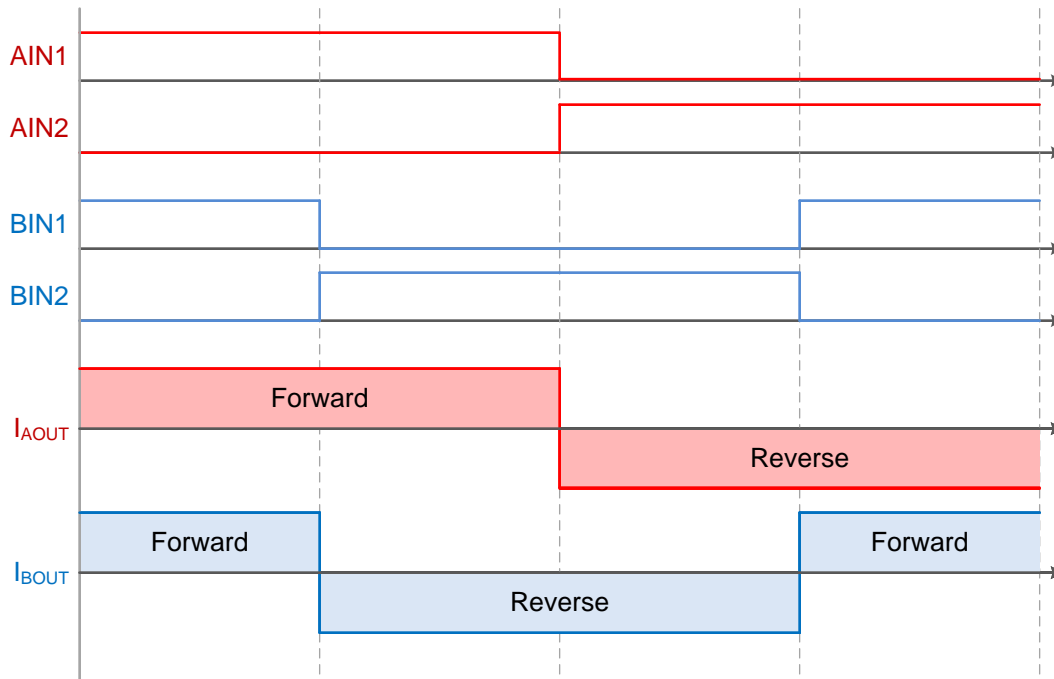

Figure 10. Full-Step Mode

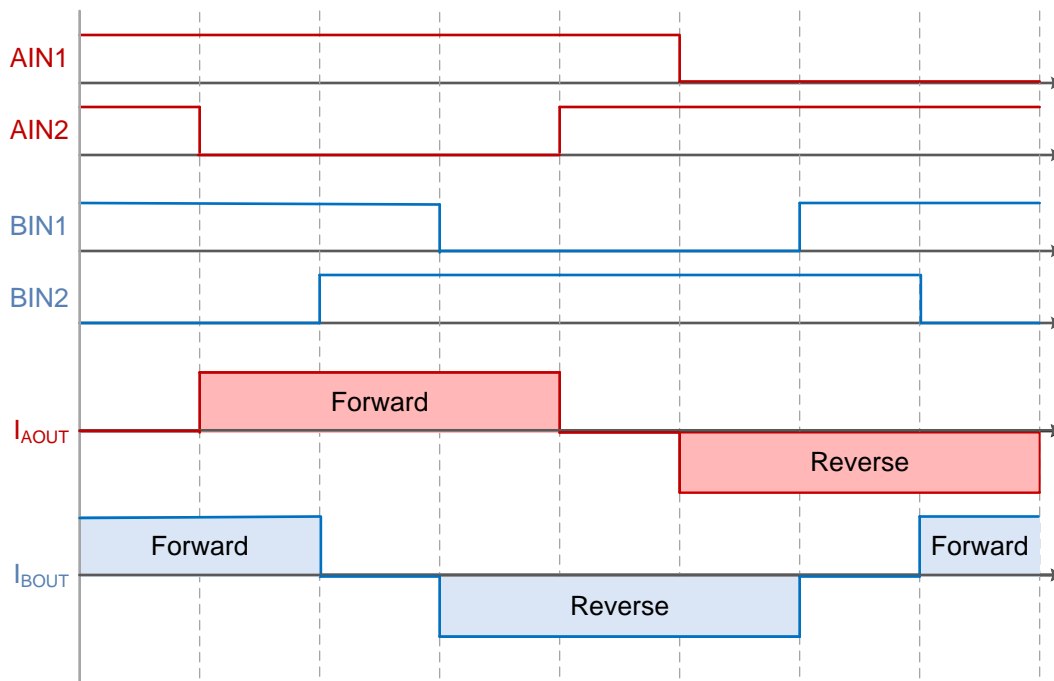

Figure 11. Half-Step Mode

8.2.2.2 Current Regulation

The chopping current (I_{CHOP}) is the maximum current driven through either winding. This quantity depends on the sense resistor value (R_{XISEN}).

$$I_{CHOP} = \frac{200 \text{ mV}}{R_{XISEN}} \quad (3)$$

I_{CHOP} is set by a comparator which compares the voltage across R_{XISEN} to a reference voltage. Note that I_{CHOP} must follow [Equation 4](#) to avoid saturating the motor.

$$I_{\text{FS}} (\text{A}) < \frac{V_{\text{M}} (\text{V})}{R_{\text{L}} (\Omega) + R_{\text{DS(ON)}} \text{HS} (\Omega) + R_{\text{DS(ON)}} \text{LS} (\Omega)}$$

where

- V_{M} is the motor supply voltage.
- R_{L} is the motor winding resistance.

(4)

8.2.3 Application Curve

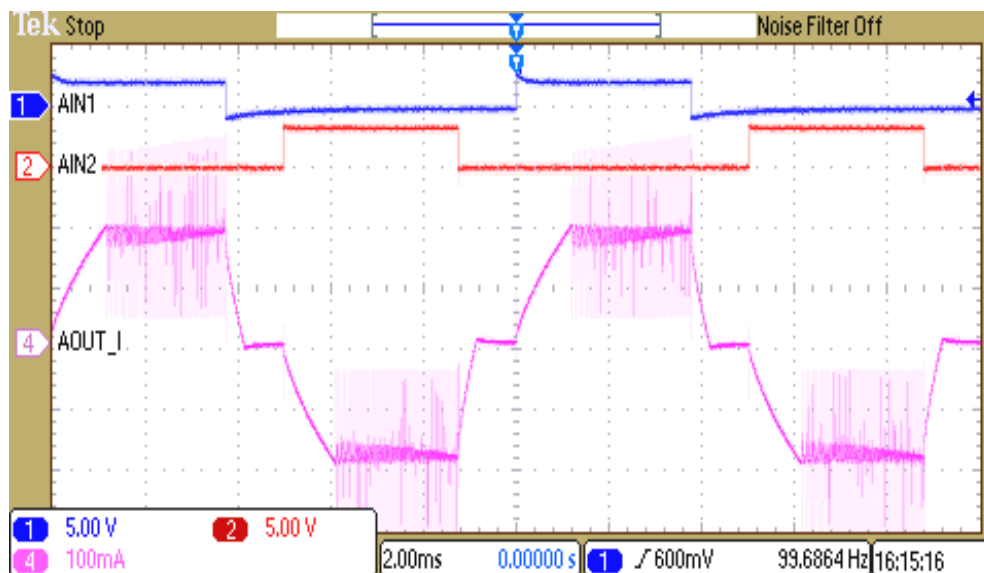

- A. Channel 1 is the AIN1 input PWM signal, and channel 2 is the AIN2 input PWM signal. BIN1 and BIN2 follow the same pattern, but are shifted by 90° from AIN1 and AIN2 as shown in [Figure 11](#). Channel 4 is the output current in the direction AOUT1 \rightarrow AOUT2. In forward and reverse drive, the current rises until it hits the current chopping limit of 200 mA, and is regulated at that level with fixed-off time current chopping.

Figure 12. $\frac{1}{2}$ Stepping Operation

9 Power Supply Recommendations

The DRV8833C is designed to operate from an input voltage supply (V_M) range between 2.7 to 10.8 V. A 10- μ F ceramic capacitor rated for V_M must be placed as close to the DRV8833C as possible.

9.1 Sizing Bulk Capacitance for Motor Drive Systems

Bulk capacitance sizing is an important factor in motor drive system design. It depends on a variety of factors including:

- Type of power supply
- Acceptable supply voltage ripple
- Parasitic inductance in the power supply wiring
- Type of motor (brushed DC, brushless DC, stepper)
- Motor startup current
- Motor braking method

The inductance between the power supply and motor drive system limits the rate current can change from the power supply. If the local bulk capacitance is too small, the system responds to excessive current demands or dumps from the motor with a change in voltage. Size the bulk capacitance to meet acceptable voltage ripple levels.

The data sheet generally provides a recommended value, but system-level testing is required to determine the appropriate-sized bulk capacitor.

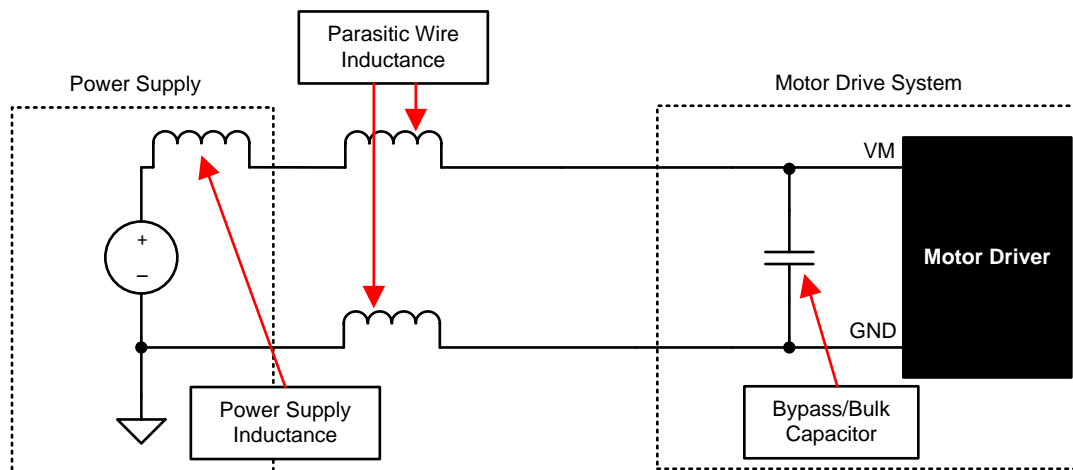

Figure 13. Setup of Motor Drive System With External Power Supply

10 Layout

10.1 Layout Guidelines

Bypass the V_M terminal to GND using a low-ESR ceramic bypass capacitor with a recommended value of $10\ \mu\text{F}$ rated for V_M . This capacitor should be placed as close to the V_M pin as possible with a thick trace or ground plane connection to the device GND pin and PowerPAD.

Bypass VINT to ground with a ceramic capacitor rated 6.3 V. Place this bypassing capacitor as close to the pin as possible.

10.2 Layout Example

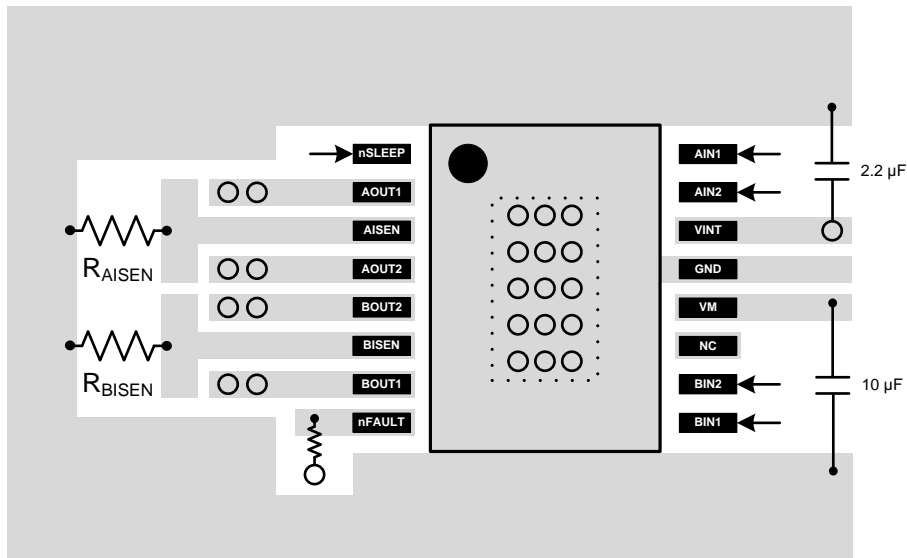

11 Device and Documentation Support

11.1 Trademarks

PowerPAD is a trademark of Texas Instruments.

11.2 Electrostatic Discharge Caution



These devices have limited built-in ESD protection. The leads should be shorted together or the device placed in conductive foam during storage or handling to prevent electrostatic damage to the MOS gates.

11.3 Glossary

[SLYZ022](#) — *TI Glossary*.

This glossary lists and explains terms, acronyms, and definitions.

12 Mechanical, Packaging, and Orderable Information

The following pages include mechanical, packaging, and orderable information. This information is the most current data available for the designated devices. This data is subject to change without notice and revision of this document. For browser-based versions of this data sheet, refer to the left-hand navigation.

PACKAGING INFORMATION

Orderable Device	Status (1)	Package Type	Package Drawing	Pins	Package Qty	Eco Plan (2)	Lead finish/ Ball material (6)	MSL Peak Temp (3)	Op Temp (°C)	Device Marking (4/5)	Samples
DRV8833CPWP	LIFEBUY	HTSSOP	PWP	16	90	RoHS & Green	NIPDAU	Level-3-260C-168 HR	-40 to 85	8833C	
DRV8833CPWPR	ACTIVE	HTSSOP	PWP	16	2000	RoHS & Green	NIPDAU	Level-3-260C-168 HR	-40 to 85	8833C	Samples
DRV8833CRTER	ACTIVE	WQFN	RTE	16	3000	RoHS & Green	NIPDAU	Level-1-260C-UNLIM	-40 to 85	8833C	Samples
DRV8833CRTET	LIFEBUY	WQFN	RTE	16	250	RoHS & Green	NIPDAU	Level-1-260C-UNLIM	-40 to 85	8833C	

(1) The marketing status values are defined as follows:

ACTIVE: Product device recommended for new designs.

LIFEBUY: TI has announced that the device will be discontinued, and a lifetime-buy period is in effect.

NRND: Not recommended for new designs. Device is in production to support existing customers, but TI does not recommend using this part in a new design.

PREVIEW: Device has been announced but is not in production. Samples may or may not be available.

OBSELETE: TI has discontinued the production of the device.

(2) **RoHS:** TI defines "RoHS" to mean semiconductor products that are compliant with the current EU RoHS requirements for all 10 RoHS substances, including the requirement that RoHS substance do not exceed 0.1% by weight in homogeneous materials. Where designed to be soldered at high temperatures, "RoHS" products are suitable for use in specified lead-free processes. TI may reference these types of products as "Pb-Free".

RoHS Exempt: TI defines "RoHS Exempt" to mean products that contain lead but are compliant with EU RoHS pursuant to a specific EU RoHS exemption.

Green: TI defines "Green" to mean the content of Chlorine (Cl) and Bromine (Br) based flame retardants meet JS709B low halogen requirements of <=1000ppm threshold. Antimony trioxide based flame retardants must also meet the <=1000ppm threshold requirement.

(3) MSL, Peak Temp. - The Moisture Sensitivity Level rating according to the JEDEC industry standard classifications, and peak solder temperature.

(4) There may be additional marking, which relates to the logo, the lot trace code information, or the environmental category on the device.

(5) Multiple Device Markings will be inside parentheses. Only one Device Marking contained in parentheses and separated by a "~" will appear on a device. If a line is indented then it is a continuation of the previous line and the two combined represent the entire Device Marking for that device.

(6) Lead finish/Ball material - Orderable Devices may have multiple material finish options. Finish options are separated by a vertical ruled line. Lead finish/Ball material values may wrap to two lines if the finish value exceeds the maximum column width.

Important Information and Disclaimer:The information provided on this page represents TI's knowledge and belief as of the date that it is provided. TI bases its knowledge and belief on information provided by third parties, and makes no representation or warranty as to the accuracy of such information. Efforts are underway to better integrate information from third parties. TI has taken and continues to take reasonable steps to provide representative and accurate information but may not have conducted destructive testing or chemical analysis on incoming materials and chemicals. TI and TI suppliers consider certain information to be proprietary, and thus CAS numbers and other limited information may not be available for release.

In no event shall TI's liability arising out of such information exceed the total purchase price of the TI part(s) at issue in this document sold by TI to Customer on an annual basis.

TAPE AND REEL INFORMATION

QUADRANT ASSIGNMENTS FOR PIN 1 ORIENTATION IN TAPE

*All dimensions are nominal

Device	Package Type	Package Drawing	Pins	SPQ	Reel Diameter (mm)	Reel Width W1 (mm)	A0 (mm)	B0 (mm)	K0 (mm)	P1 (mm)	W (mm)	Pin1 Quadrant
DRV8833CPWPR	HTSSOP	PWP	16	2000	330.0	12.4	6.9	5.6	1.6	8.0	12.0	Q1
DRV8833CRTER	WQFN	RTE	16	3000	330.0	12.4	3.3	3.3	1.1	8.0	12.0	Q2
DRV8833CRTET	WQFN	RTE	16	250	180.0	12.4	3.3	3.3	1.1	8.0	12.0	Q2

TAPE AND REEL BOX DIMENSIONS



*All dimensions are nominal

Device	Package Type	Package Drawing	Pins	SPQ	Length (mm)	Width (mm)	Height (mm)
DRV8833CPWPR	HTSSOP	PWP	16	2000	350.0	350.0	43.0
DRV8833CATER	WQFN	RTE	16	3000	335.0	335.0	25.0
DRV8833CARTET	WQFN	RTE	16	250	182.0	182.0	20.0

TUBE

*All dimensions are nominal

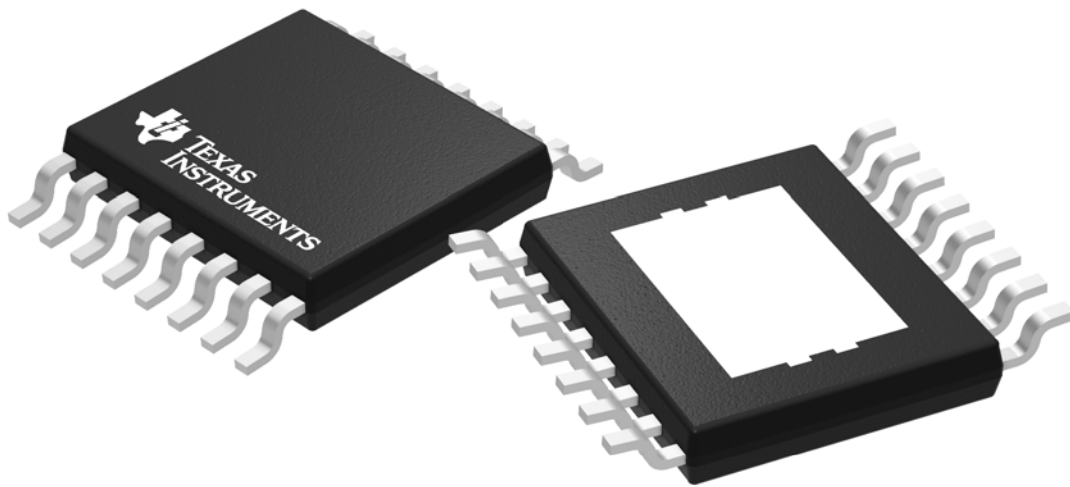
Device	Package Name	Package Type	Pins	SPQ	L (mm)	W (mm)	T (μm)	B (mm)
DRV8833CPWP	PWP	HTSSOP	16	90	530	10.2	3600	3.5



Images above are just a representation of the package family, actual package may vary.
Refer to the product data sheet for package details.

GENERIC PACKAGE VIEW

RTE 16

WQFN - 0.8 mm max height

3 x 3, 0.5 mm pitch

PLASTIC QUAD FLATPACK - NO LEAD

This image is a representation of the package family, actual package may vary.
Refer to the product data sheet for package details.



4225944/A



SIDE WALL METAL THICKNESS DIM A	
OPTION 1	OPTION 2
0.1	0.2

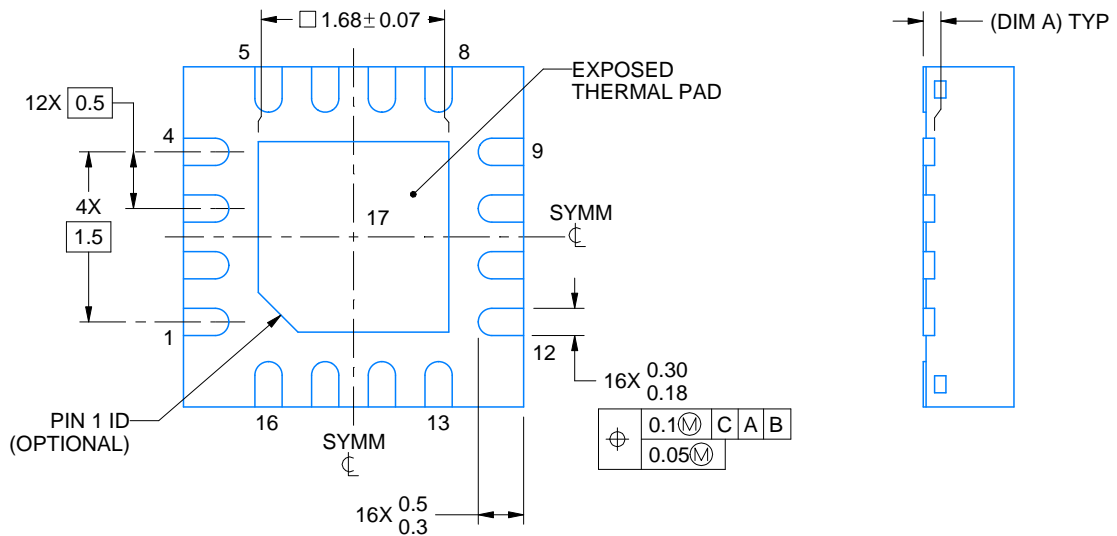
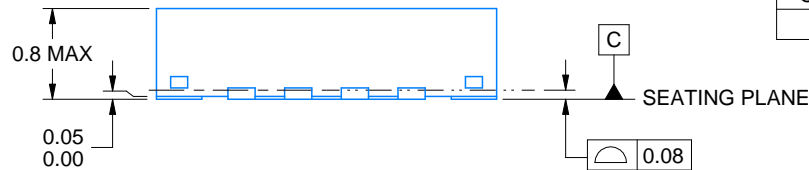

4219117/B 04/2022

NOTES:

1. All linear dimensions are in millimeters. Any dimensions in parenthesis are for reference only. Dimensioning and tolerancing per ASME Y14.5M.
2. This drawing is subject to change without notice.
3. The package thermal pad must be soldered to the printed circuit board for thermal and mechanical performance.

EXAMPLE BOARD LAYOUT

RTE0016C

WQFN - 0.8 mm max height

PLASTIC QUAD FLATPACK - NO LEAD

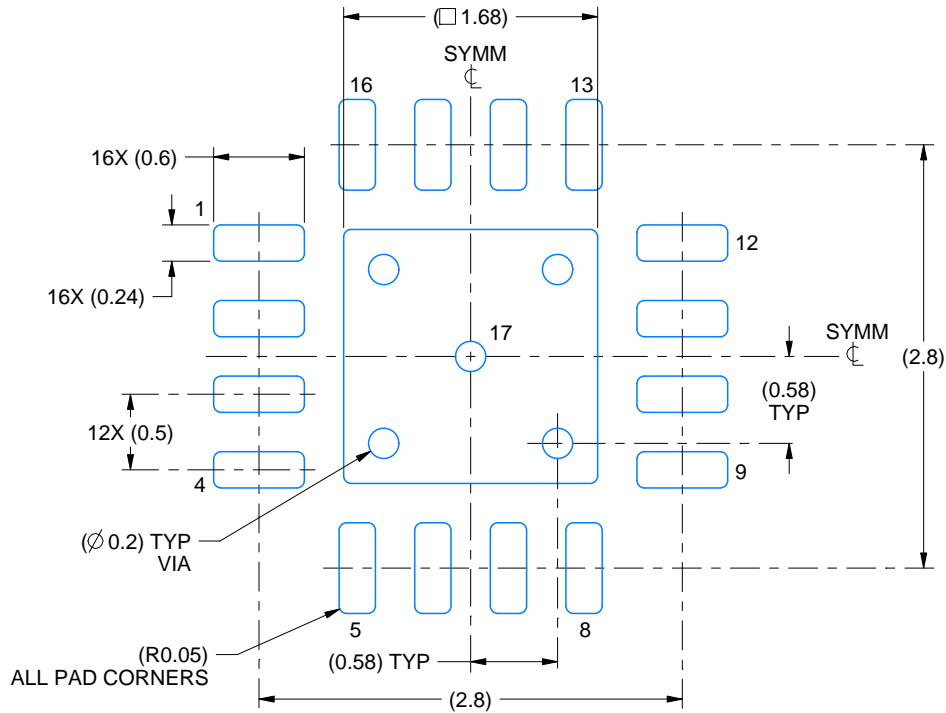

LAND PATTERN EXAMPLE
EXPOSED METAL SHOWN
SCALE:20X

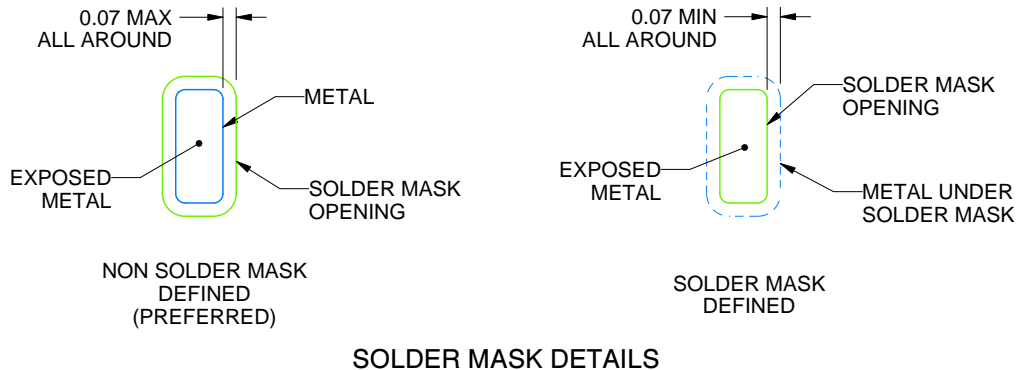

SOLDER MASK DETAILS

4219117/B 04/2022

NOTES: (continued)

- This package is designed to be soldered to a thermal pad on the board. For more information, see Texas Instruments literature number SLUA271 (www.ti.com/lit/slua271).
- Vias are optional depending on application, refer to device data sheet. If any vias are implemented, refer to their locations shown on this view. It is recommended that vias under paste be filled, plugged or tented.

EXAMPLE STENCIL DESIGN

RTE0016C

WQFN - 0.8 mm max height

PLASTIC QUAD FLATPACK - NO LEAD



SOLDER PASTE EXAMPLE
BASED ON 0.125 mm THICK STENCIL

EXPOSED PAD 17:
85% PRINTED SOLDER COVERAGE BY AREA UNDER PACKAGE
SCALE:25X

4219117/B 04/2022

NOTES: (continued)

6. Laser cutting apertures with trapezoidal walls and rounded corners may offer better paste release. IPC-7525 may have alternate design recommendations.

IMPORTANT NOTICE AND DISCLAIMER

TI PROVIDES TECHNICAL AND RELIABILITY DATA (INCLUDING DATA SHEETS), DESIGN RESOURCES (INCLUDING REFERENCE DESIGNS), APPLICATION OR OTHER DESIGN ADVICE, WEB TOOLS, SAFETY INFORMATION, AND OTHER RESOURCES "AS IS" AND WITH ALL FAULTS, AND DISCLAIMS ALL WARRANTIES, EXPRESS AND IMPLIED, INCLUDING WITHOUT LIMITATION ANY IMPLIED WARRANTIES OF MERCHANTABILITY, FITNESS FOR A PARTICULAR PURPOSE OR NON-INFRINGEMENT OF THIRD PARTY INTELLECTUAL PROPERTY RIGHTS.

These resources are intended for skilled developers designing with TI products. You are solely responsible for (1) selecting the appropriate TI products for your application, (2) designing, validating and testing your application, and (3) ensuring your application meets applicable standards, and any other safety, security, regulatory or other requirements.

These resources are subject to change without notice. TI grants you permission to use these resources only for development of an application that uses the TI products described in the resource. Other reproduction and display of these resources is prohibited. No license is granted to any other TI intellectual property right or to any third party intellectual property right. TI disclaims responsibility for, and you will fully indemnify TI and its representatives against, any claims, damages, costs, losses, and liabilities arising out of your use of these resources.

TI's products are provided subject to [TI's Terms of Sale](#) or other applicable terms available either on [ti.com](https://www.ti.com) or provided in conjunction with such TI products. TI's provision of these resources does not expand or otherwise alter TI's applicable warranties or warranty disclaimers for TI products.

TI objects to and rejects any additional or different terms you may have proposed.

Mailing Address: Texas Instruments, Post Office Box 655303, Dallas, Texas 75265
Copyright © 2024, Texas Instruments Incorporated