

# EiceDRIVER™

2EDN752x / 2EDN852x

Dual Channel 5A, High-Speed, Low-Side Gate Driver With High Negative Input Voltage Capability

## EiceDRIVER™

Fast Dual Channel Low-Side Gate Driver

## Preliminary Data Sheet

Revision 1.0, 2015-05-12

Changes possible without notice

Power Management and Multimarket

---

<b>Revision History , Revision 1.0, 2015-05-12</b>			
<b>Page/ Item</b>	<b>Subjects (major changes since previous revision)</b>	<b>Responsible</b>	<b>Date</b>
	updated from internal version 0.50	Tobias Gerber	2015/05/12

## Table of Contents

	<b>Table of Contents</b> .....	<b>3</b>
	<b>Fast Dual Channel 5 A Low-Side Gate Driver</b> .....	<b>4</b>
<b>1</b>	<b>Product Versions</b> .....	<b>6</b>
1.1	Undervoltage Lockout Versions	6
1.2	Logic Versions	6
1.3	Package Versions	7
<b>2</b>	<b>Pin Configuration and Description</b> .....	<b>8</b>
<b>3</b>	<b>Block Diagram</b> .....	<b>9</b>
<b>4</b>	<b>Functional Description</b> .....	<b>11</b>
4.1	Introduction	11
4.2	Supply Voltage	11
4.3	Input Configurations	11
4.4	Driver Outputs	11
4.5	Undervoltage Lockout (UVLO)	11
<b>5</b>	<b>Characteristics</b> .....	<b>13</b>
5.1	Absolute Maximum Ratings	13
5.2	Thermal Characteristics	13
5.3	Operating Range	14
5.4	Electrical Characteristics	14
<b>6</b>	<b>Timing Diagrams</b> .....	<b>17</b>
<b>7</b>	<b>Typical Characteristics</b> .....	<b>19</b>
<b>8</b>	<b>Outline Dimensions</b> .....	<b>22</b>



## Fast Dual Channel 5 A Low-Side Gate Driver

### Main Features

- Industry-Standard Pinout
- Two Independent Low-Side Gate Drivers
- 5 A Peak Sink/Source Output Driver at VDD = 12 V
- -10 Vdc Negative Input Capability against GND-Bouncing
- Enhanced operating robustness due to High Reverse Current Capability
- True Low-Impedance Rail-To-Rail Output (0.7  $\Omega$  and 0.55  $\Omega$ )
- Very Low Propagation Delay (19 ns)
- Typ. 1 ns Channel to Channel Delay Matching
- Wide Input and Output Voltage Range up to 20 V
- Active Low Output Driver even on Low Power or Disabled Driver
- High Flexibility through Different Logic Input Configurations (LVTTTL and CMOS 3.3 V)
- PG-DSO-8, PG-WSON-8-1 and PG-TSSOP-8-1 Package
- Extended Operation from -40 °C to 150 °C (Junction Temperature)
- Particularly Well-Suited for Driving Standard, Superjunction MOSFETs, IGBTs or GaN Power Devices

### Typical Applications

- SMPS
- DC-to-DC Converters
- Motor Control
- Solar Power, Industrial Applications

### Description

The Fast Dual Channel 5A Low-Side Gate Driver is an advanced dual-channel driver optimized for driving both Standard and Superjunction MOSFETs, as well as GaN Power devices, in all applications in which they are commonly used. The input signals are TTL compatible (CMOS 3.3V) with an input voltage range from 3V to +20V. The ability to operate with -10V<sub>DC</sub> at the input pins protects the device against ground bounce conditions. Each of the two outputs is able to sink and source a 5 A current utilizing a true rail-to-rail stage, that ensures very low impedances of 0.7  $\Omega$  up to the positive and 0.55  $\Omega$  down to the negative rail respectively. Very low channel to channel delay matching, typ. 1 ns, enables the double source and sink capability of 10 A, by paralleling both channels. Different logic input/output configurations guarantee high flexibility in all applications; e.g. with two paralleled switches in a boost configuration (see Figure below). The gate driver is available in the three package options: A standard PG-DSO-8, a thin PG-WSON-8-1 and PG-TSSOP-8-1 (minimized DSO 8 package).



PG-DSO-8

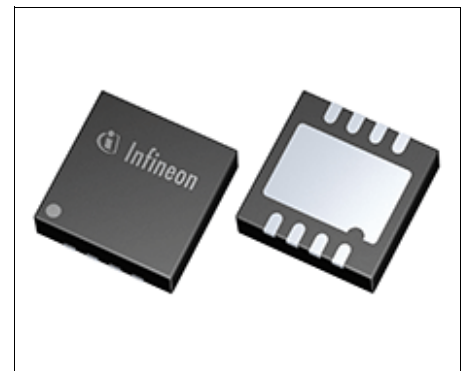

PG-WSON-8-1

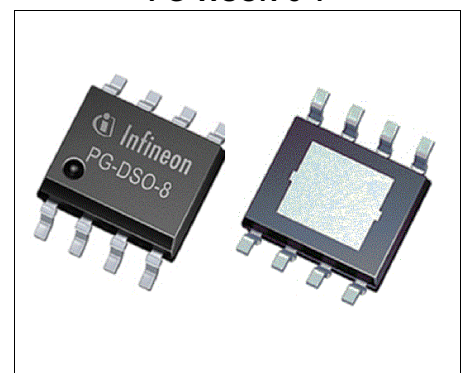

PG-TSSOP-8-1

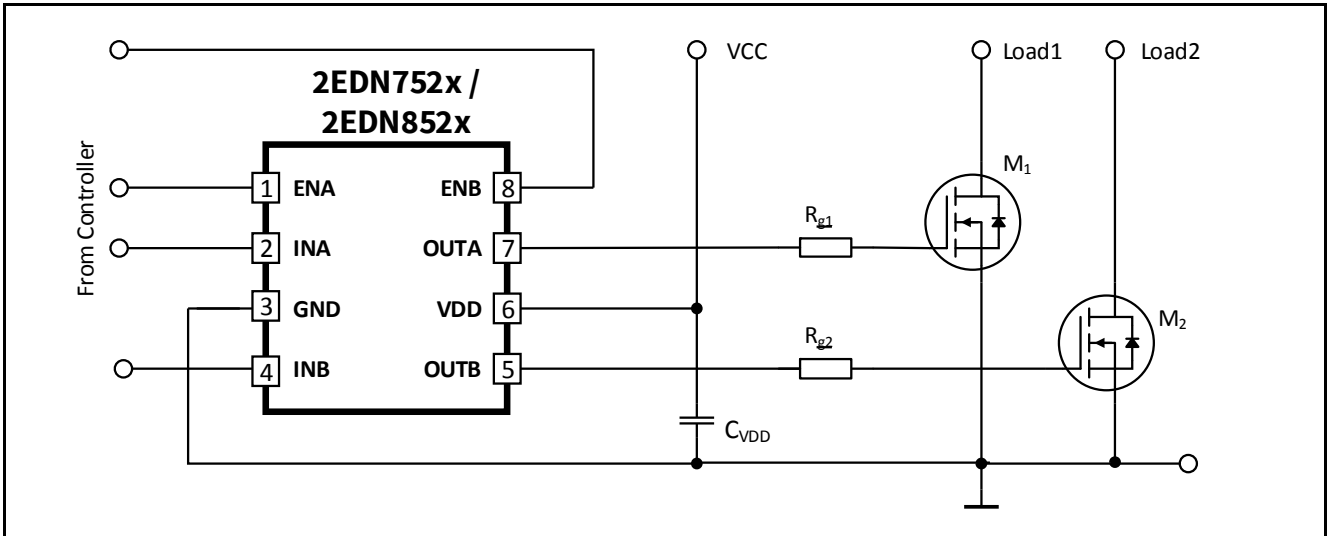

Figure 0-1 Typical Application

## Product Versions

# 1 Product Versions

The 2EDN752x / 2EDN852x is available in 2 different logic, 2 different undervoltage lockout and 3 package versions.

**Table 1-1 Product Versions**

Part Number	Description	Package	Order Code
2EDN7523F	inverting input, standard UVLO	PG-DSO-8	SP001358244
2EDN7524F	standard input, standard UVLO	PG-DSO-8	SP001339264
2EDN7524G	standard input, standard UVLO	PG-WSON-8-1	tbd
2EDN7524R	standard input, standard UVLO	PG-TSSOP-8-1	tbd
2EDN8524G	standard input, superjunction UVLO	PG-WSON-8-1	tbd

## 1.1 Undervoltage Lockout Versions

The two Undervoltage Lockout versions are indicated by the variable x in the product version 2EDNx52y:

- x=7: lower voltage level (4.2V)
- x=8: higher voltage level (8.0V)

Please go to the functional description section for more details in [Chapter 4 Undervoltage Lockout \(UVLO\)](#).

## 1.2 Logic Versions

The 2 logic versions are indicated by the variable y in the product version 2EDNx52y:

- y=3: inverting
- y=4: standard (non-inverting)

The logic relations between inputs, enable pins and outputs are given in [Table 1-2](#) for the inverting and standard version 2EDNx523 and 2EDNx524. The state of the driving output is defined by the state of the respective input, if the enable inputs ENA and ENB are high (or left open). A logic “low” at an enable input or an undervoltage lockout event, due to low voltage at VDD, causes the respective output to be low too, regardless of the input signal.

Product Versions

Table 1-2 Logic Table

Inputs					Output Inverting		Output non-inverting	
ENA	ENB	INA	INB	<sup>1)</sup> UVLO	OUTA	OUTB	OUTA	OUTB
x	x	x	x	active	L	L	L	L
L	L	x	x	inactive	L	L	L	L
H	L	L	x	inactive	H	L	L	L
H	L	H	x	inactive	L	L	H	L
L	H	x	L	inactive	L	H	L	L
L	H	x	H	inactive	L	L	L	H
H	H	L	L	inactive	H	H	L	L
H	H	H	L	inactive	L	H	H	L
H	H	L	H	inactive	H	L	L	H
H	H	H	H	inactive	L	L	H	H

1) Active means that Vcc is above UVLO threshold voltage and release logic to control output stage.  
Inactive means that UVLO disable active the output stage.

### 1.3 Package Versions

Most of the logic versions and UVLO versions are available in 3 different packages.

- a standard PG-DSO-8 (designated by "F")
- a leadless PG-WSON-8-1 (designated by "G")
- a small PG-TSSOP-8-1 (designated by "R")

Drawings can be viewed in [Chapter 8 Outline Dimensions](#).

Pin Configuration and Description

## 2 Pin Configuration and Description

The pin configuration for the inverting and standard input version of 2EDN7523F and 2EDN7524F in the PG-DSO-8 package is shown in [Figure 2-1](#).

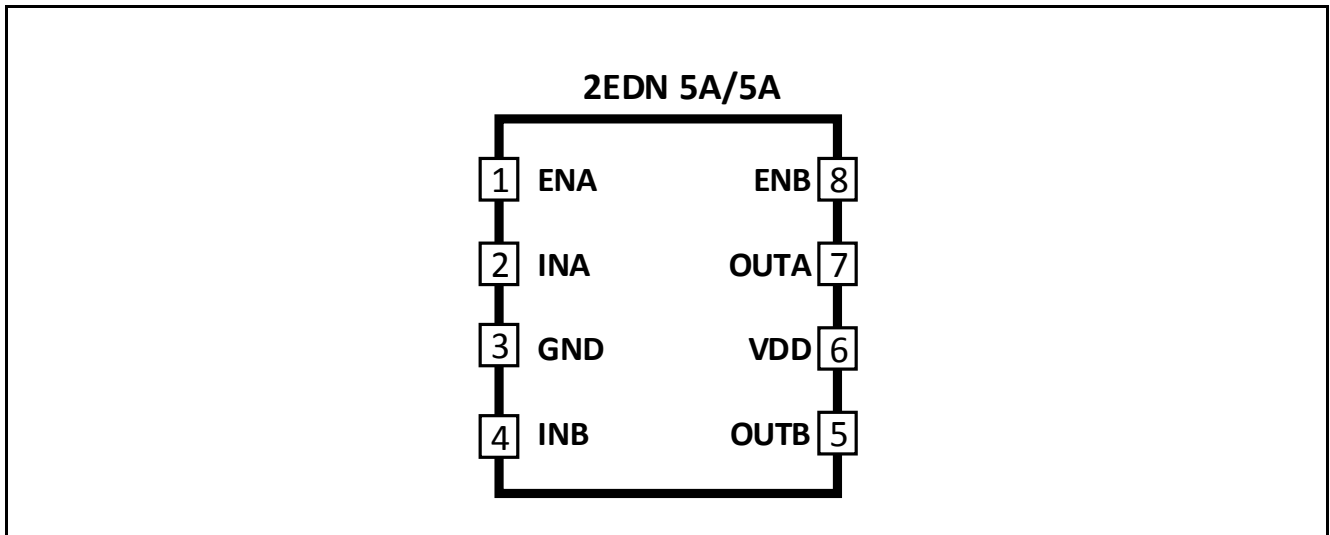

**Figure 2-1 Pin Configuration PG-DSO-8**

**Table 2-1 Pin Configuration**

Pin	Symbol	Description
1	ENA	Enable Input channel A Logic Input; if ENA is high or left open, OUTA is controlled by INA; ENA low causes OUTA low
2	INA	Input Signal channel A Logic Input, controlling OUTA (inverting or non-inverting)
3	GND	Ground
4	INB	Input Signal channel B Logic Input, controlling OUTB (inverting or non-inverting)
5	OUTB	Driver Output Channel B Low-impedance output with source and sink capability
6	VDD	Positive Supply Voltage Operating range 4.5 to 20V
7	OUTA	Driver Output Channel A Low-impedance output with source and sink capability
8	ENB	Enable Input channel B Logic Input; if ENA is high or left open, OUTA is controlled by INA; ENA low causes OUTA low

The pin configuration in the PG-WSON-8-1 and PG-TSSOP-8-1 packages are identical to PG-DSO-8. Heat sink pad has to be connected to GND pin.

Block Diagram

### 3 Block Diagram

A simplified functional block diagram for the non-inverted version is given in [Figure 3-1](#)

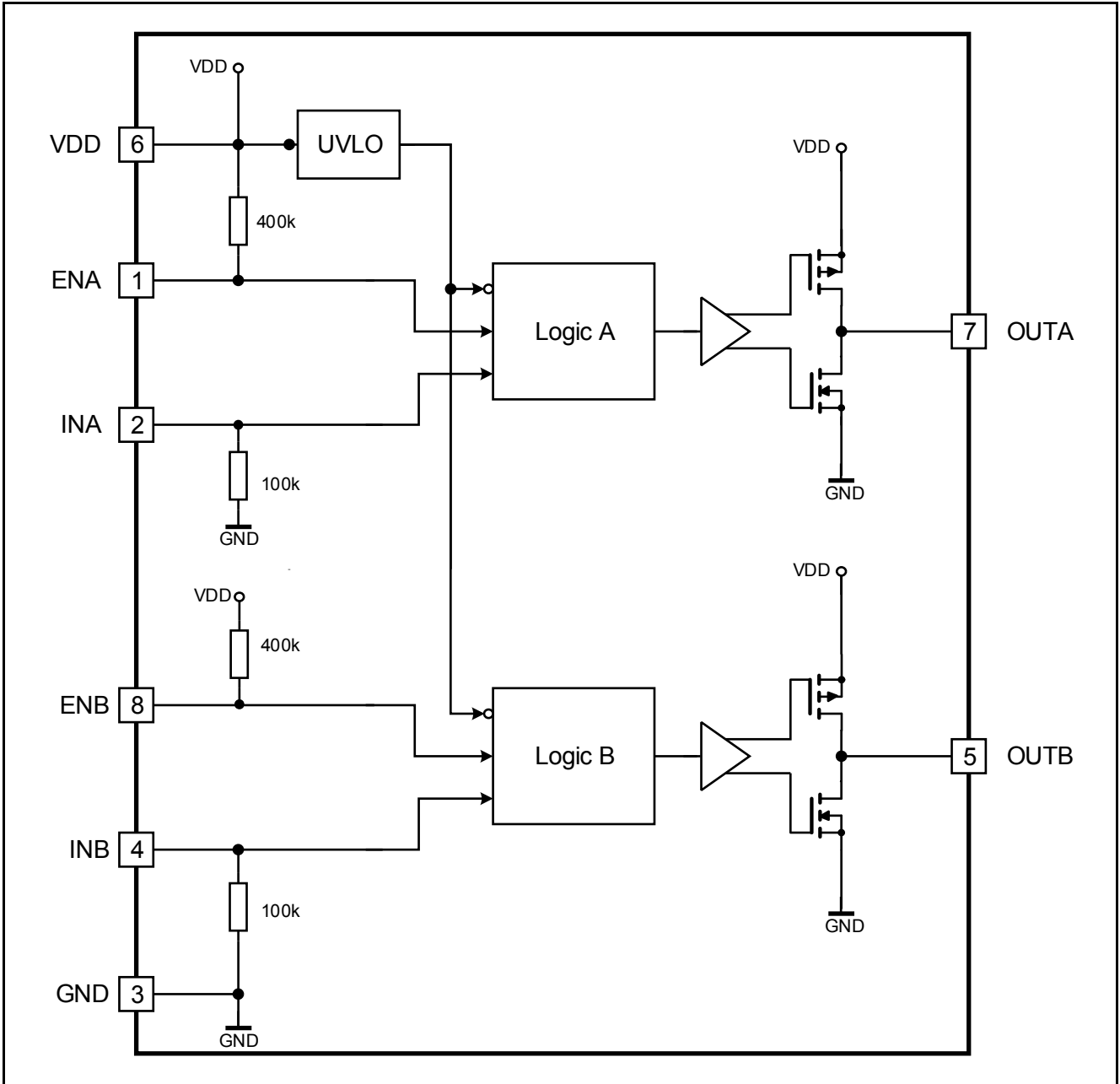

**Figure 3-1 Block Diagram, standard input, pull-up/pull-down resistor configuration**

A simplified functional block diagram for the inverted version is given in [Figure 3-2](#).

Block Diagram

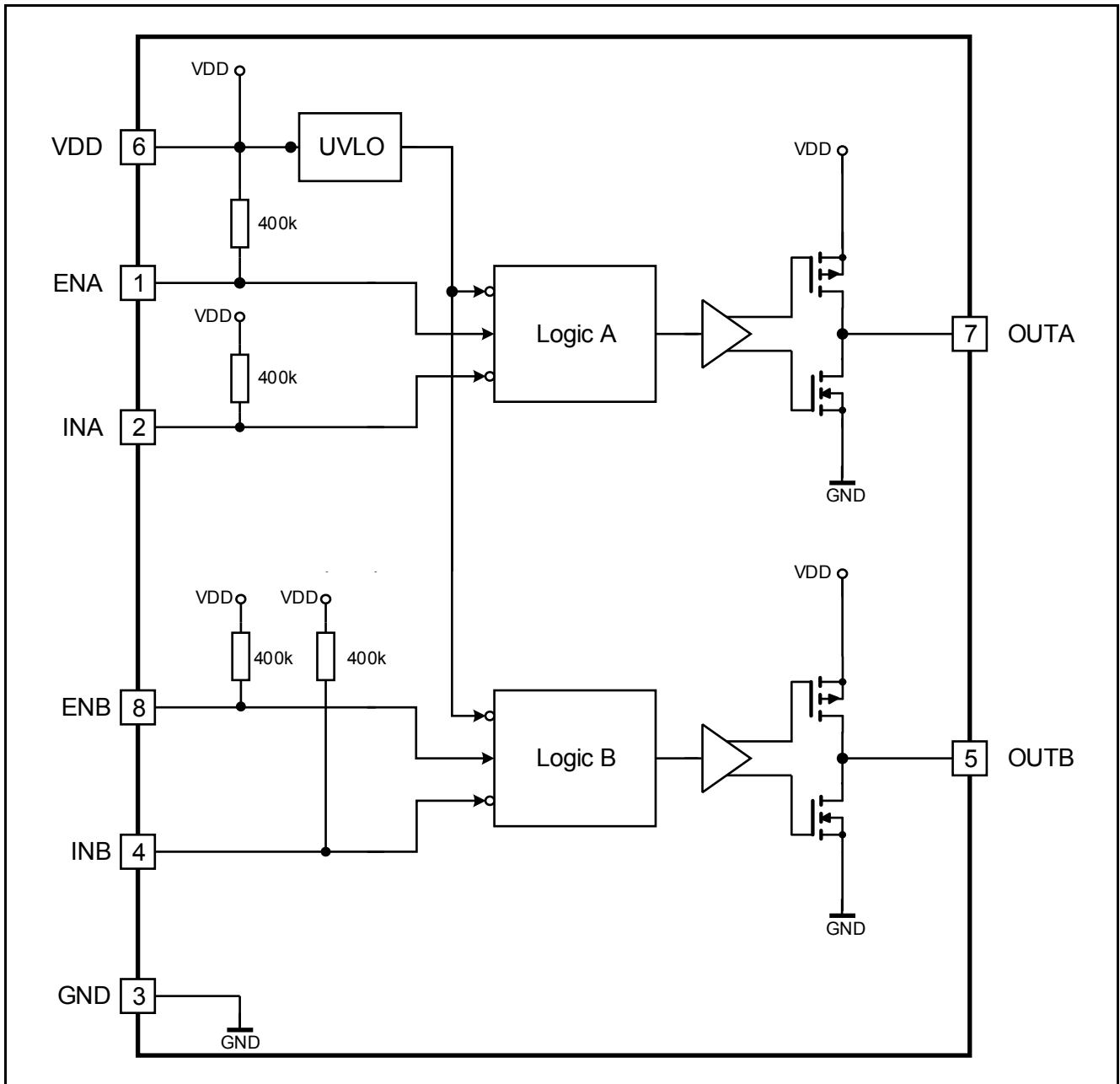

Figure 3-2 Block Diagram, inverting input, pull-up/pull-down resistor configuration

## **4 Functional Description**

### **4.1 Introduction**

The 2EDN752x / 2EDN852x is a fast dual-channel driver for low-side switches. Two true rail-to-rail output stages with very low output impedance and high current capability are chosen to ensure highest flexibility and cover a high variety of applications.

All inputs are compatible with LVTTTL signal levels. The threshold voltages with a typical hysteresis of 1V are kept constant over the supply voltage range.

Since the 2EDN752x / 2EDN852x aims particularly at fast-switching applications, signal delays and rise/fall times have been minimized. Special effort has been made towards minimizing delay differences between the 2 channels to very low values of typically 1ns.

### **4.2 Supply Voltage**

The maximum supply voltage is 20V. This high voltage can be valuable in order to exploit the full current capability of 2EDN752x / 2EDN852x when driving very large MOSFETs. The minimum operating supply voltage is set by the undervoltage lockout function to a typical default value of 4.2V or of 8V.

### **4.3 Input Configurations**

As described in [Chapter 1](#), 2EDN752x / 2EDN852x is available in 2 different configurations with respect to the logic configuration of the 4 input pins (input plus enable).

The enable inputs are internally pulled up to a logic high voltage, i. e. the driver is enabled with these pins left open. The PWM inputs are internally pulled down to a logic low voltage. This prevents a switch-on event during power up.

All inputs are compatible with LVTTTL levels and provide a hysteresis of 1V typ. It is independent of the supply voltage.

All input pins have a negative extended voltage range. This prevents cross current over single wires during GND shifts between signal source (controller) and driver input.

### **4.4 Driver Outputs**

The two rail-to-rail output stages realized with complementary MOS transistors are able to provide a typical 5A of sourcing and sinking current. The on-resistance is very low with a typical value below 0.7  $\Omega$  for the sourcing pMOS and 0.5  $\Omega$  for the sinking nMOS transistor. The use of a p-channel sourcing transistor is crucial for achieving real rail-to-rail behaviour and not suffering from a source follower's voltage drop.

Gate Drive Outputs held active low in case of floating inputs ENx, INx or during startup or power down once UVLO is not exceeded.

### **4.5 Undervoltage Lockout (UVLO)**

The Undervoltage Lockout function ensures that the output can be switched to its high level only, if the supply voltage exceeds the UVLO threshold voltage. Thus it can be guaranteed, that the switch transistor is not operated if the driving voltage is too low to completely switch it on, thereby avoiding excessive power dissipation.

---

**Functional Description**

The default UVLO level is set to a typical value of 4.2V / 8V (with some hysteresis). UVLO of 4.2V is normally used for low voltage and TTL based MOSFETs. For higher level, like high voltage super junction MOSFETS, an active voltage of min. 8V is used.

## Characteristics

### 5 Characteristics

The absolute maximum ratings are listed in [Table 5-1](#). Stresses beyond these values may cause permanent damage to the device. Exposure to absolute maximum rating conditions for extended periods may affect device reliability.

#### 5.1 Absolute Maximum Ratings

**Table 5-1 Absolute Maximum Ratings**

Parameter	Symbol	Values			Unit	Note or Test Condition
		Min.	Typ.	Max.		
Positive supply voltage	$V_{VDD}$	-0.3		22	V	
Voltage at pins INA, INB, ENA, ENB	$V_{IN}$	-10		22	V	
Voltage at pins OUTA, OUTB	$V_{OUT}$	-0.3		$V_{VDD}+0.3$	V	
Junction temperature	$T_J$	-40		150	°C	
Storage temperature	$T_S$	-65		150	°C	
Soldering temperature				260	°C	Reflow Soldering <sup>1)</sup>
Soldering temperature				260	°C	Wave Soldering <sup>1)</sup>
ESD capability	$V_{ESD}$			2 1.6	kV	Human Body Model <sup>2)/</sup> Charge Device Model <sup>3)</sup>

1) According to JESD22A111

2) According to EIA/JESD22-A114-B (discharging 100 pF Capacitor through 1.5 kOhm resistor)

3) tbd

#### 5.2 Thermal Characteristics

**Table 5-2 Thermal Characteristics**

Parameter	Symbol	Values			Unit	Note or Test Condition
		Min.	Typ.	Max.		
Thermal resistance junction-ambient	$R_{thJA25}$		tbd		K/W	PG-DSO-8, TA=25°C
Thermal resistance junction-case (top)	$R_{thJP25}$		tbd		K/W	PG-DSO-8, TA=25°C
Thermal resistance junction-board <sup>1)</sup>	$R_{thJB25}$		tbd		K/W	PG-DSO-8, TA=25°C
Thermal resistance junction-ambient	$R_{thJA25}$		tbd		K/W	PG-WSON-8-1, TA=25°C
Thermal resistance junction-case (top)	$R_{thJP25}$		tbd		K/W	PG-WSON-8-1, TA=25°C
Thermal resistance junction-board <sup>1)</sup>	$R_{thJB25}$		tbd		K/W	PG-WSON-8-1, TA=25°C

## Characteristics

**Table 5-2 Thermal Characteristics**

Parameter	Symbol	Values			Unit	Note or Test Condition
		Min.	Typ.	Max.		
Thermal resistance junction-ambient	$R_{thJA25}$		tbd		K/W	PG-TSSOP-8-1, TA=25°C
Thermal resistance junction-case (top)	$R_{thJP25}$		tbd		K/W	PG-TSSOP-8-1, TA=25°C
Thermal resistance junction-board <sup>1)</sup>	$R_{thJB25}$		tbd		K/W	PG-TSSOP-8-1, TA=25°C

1) Junction to board resistance is a simulation result according JESD51-8

## 5.3 Operating Range

**Table 5-3 Operating Range**

Parameter	Symbol	Values			Unit	Note or Test Condition
		Min.	Typ.	Max.		
Supply voltage	$V_{VDD}$	4.5		20	V	Min defined by UVLO
Logic input voltage	$V_{IN}$	-5		20	V	
Junction temperature	$T_J$	-40		150	°C	1)

1) Continuous operation above 125 °C may reduce life time.

## 5.4 Electrical Characteristics

Unless otherwise noted, min./max. values of characteristics are the lower and upper limits respectively. They are valid within the full operating range. Typical values are given at  $T_J=25^\circ\text{C}$ ; the supply voltage is  $V_{VDD}=12\text{ V}$ .

**Table 5-4 Power Supply**

Parameter	Symbol	Values			Unit	Note or Test Condition
		Min.	Typ.	Max.		
VDD quiescent current	$I_{VDDqu1}$	0.5	0.7	1.2	mA	OUT = high, $V_{VDD}=12\text{ V}$
VDD quiescent current	$I_{VDDqu2}$	0.3	0.48	0.7	mA	OUT = low, $V_{VDD}=12\text{ V}$

**Table 5-5 Undervoltage Lockout Standard MOSFET**

Parameter	Symbol	Values			Unit	Note or Test Condition
		Min.	Typ.	Max.		
Undervoltage Lockout (UVLO) turn on threshold	$UVLO_{on}$	3.9	4.2	4.5	V	
Undervoltage Lockout (UVLO) turn off threshold	$UVLO_{off}$	3.6	3.9	4.2	V	
UVLO threshold hysteresis	$UVLO_{hys}$		0.3		V	

## Characteristics

**Table 5-6 Undervoltage Lockout Superjunction MOSFET**

Parameter	Symbol	Values			Unit	Note or Test Condition
		Min.	Typ.	Max.		
Undervoltage Lockout (UVLO) turn on threshold	UVLO <sub>on</sub>	7.4	8.0	8.6	V	
Undervoltage Lockout (UVLO) turn off threshold	UVLO <sub>off</sub>	6.5	7.0	7.5	V	
UVLO threshold hysteresis	UVLO <sub>hys</sub>	—	1.0	—	V	

**Table 5-7 Logic Inputs INA, INB, ENA, ENB**

Parameter	Symbol	Values			Unit	Note or Test Condition
		Min.	Typ.	Max.		
Input voltage threshold for transition LH	V <sub>INH</sub>	1.9	2.1	2.3	V	
Input voltage threshold for transition HL	V <sub>INL</sub>	0.8	1.0	1.2	V	
Input pull up resistor <sup>1)</sup>	R <sub>INH</sub>		400		kΩ	
Input pull down resistor <sup>2)</sup>	R <sub>INL</sub>		100		kΩ	

1) Inputs with initial high logic level

2) Inputs with initial low logic level

**Table 5-8 Static Output Characteristics (see Figure 6-2)**

Parameter	Symbol	Values			Unit	Note or Test Condition
		Min.	Typ.	Max.		
High Level (Sourcing) Output Resistance	R <sub>on_SNK</sub>	0.35	0.7	1.2	Ω	I <sub>SNK</sub> = 50mA
High Level (Sourcing) Output Current	I <sub>SNK_peak</sub>		5.0		A	
Low Level (Sinking) Output Resistance	R <sub>on_SRC</sub>	0.28	0.55	1.0	Ω	I <sub>SRC</sub> = 50mA
High Level (Sinking) Output Current	I <sub>SRC_Peak</sub>		-5.0		A	

**Table 5-9 Dynamic Characteristics (see Figure 6-1, Figure 6-2, Figure 6-3 and Figure 6-4)**

Parameter	Symbol	Values			Unit	Note or Test Condition
		Min.	Typ.	Max.		
Input/Enable to output propagation delay	T <sub>PDON</sub>	15	19	25	ns	C <sub>LOAD</sub> =1.8 nF
Input/Enable to output propagation delay	T <sub>PDOFF</sub>	15	19	25	ns	C <sub>LOAD</sub> =1.8 nF

Characteristics

Table 5-9 Dynamic Characteristics (see Figure 6-1, Figure 6-2, Figure 6-3 and Figure 6-4)

Parameter	Symbol	Values			Unit	Note or Test Condition
		Min.	Typ.	Max.		
Input/Enable to output propagation delay mismatch between channels	$Dt_{PD}$		1	4	ns	
Rise Time	$T_{RISE}$	—	5.3	tbd	ns	$C_{LOAD} = 1.8 \text{ nF}, V_{VDD} = 12 \text{ V}$
Fall Time	$T_{FALL}$	—	4.5	tbd	ns	$C_{LOAD} = 1.8 \text{ nF}, V_{VDD} = 12 \text{ V}$
Minimum input pulse width that changes output state	$T_{PW}$	—	10	20	ns	$C_{LOAD} = 1.8 \text{ nF}, V_{VDD} = 12 \text{ V}$

Timing Diagrams

## 6 Timing Diagrams

Figure 6-1 shows the definition of rise, fall and delay times for the inputs of the non-inverting version (with Enable pin high or open).

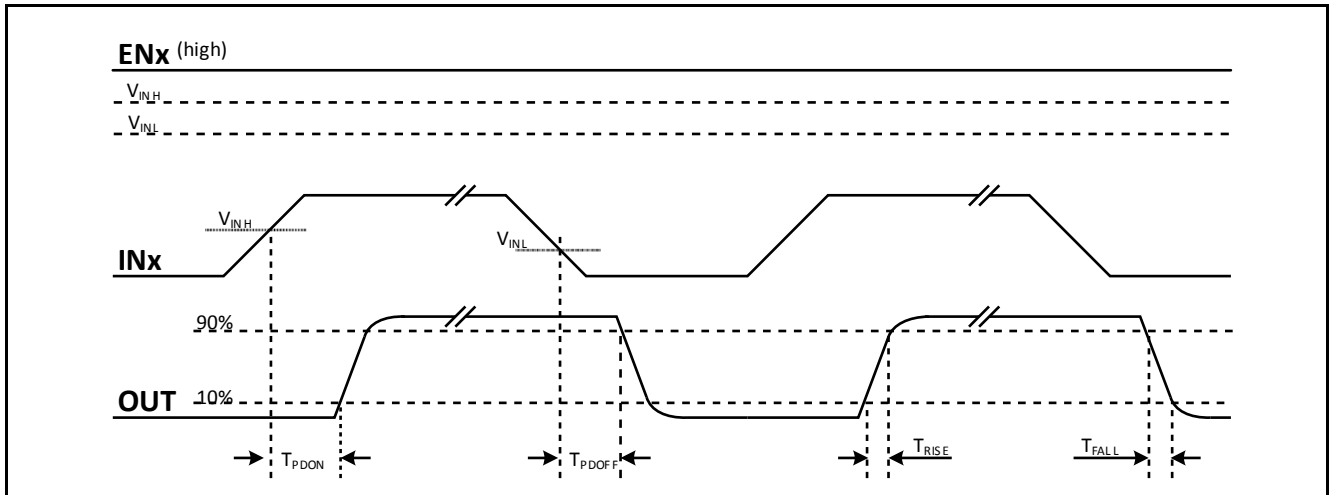

Figure 6-1 Propagation Delay, Rise and Fall Time, Non-inverted

Figure 6-2 shows the definition of rise, fall and delay times for the inputs of the inverting version (with enable pins high or open).

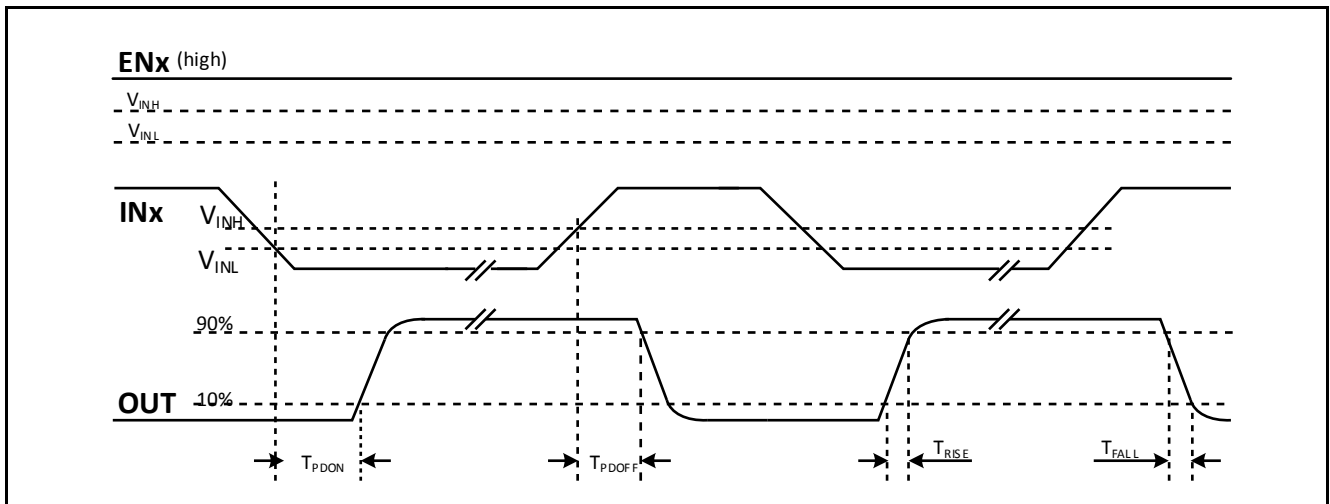

Figure 6-2 Propagation Delay, Rise and Fall Time, Inverted

Figure 6-3 illustrates the undervoltage lockout function.

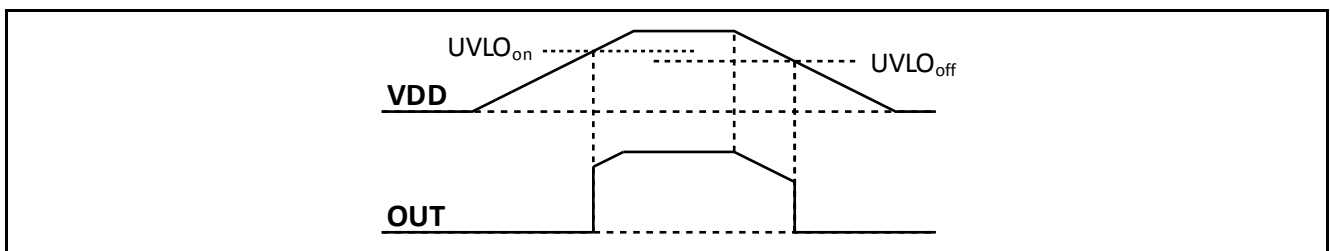

Figure 6-3 UVLO Behaviour, Input ENx and INx drives OUT normally high

Timing Diagrams

Figure 6-4 illustrates the minimum input pulse width that changes output state.

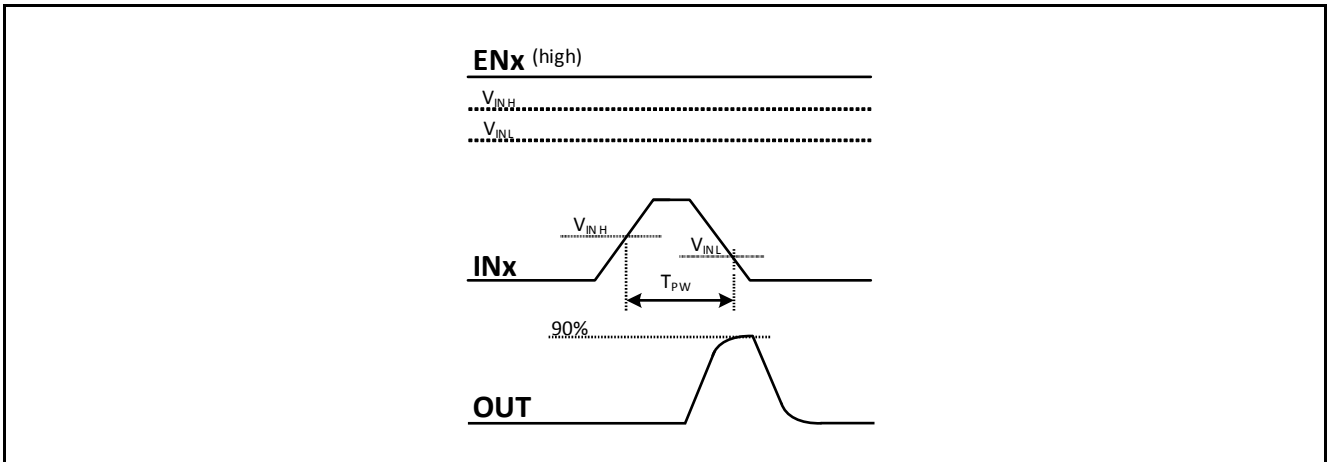

Figure 6-4  $T_{PW}$ , minimum input pulse width that changes output state

Typical Characteristics

7 Typical Characteristics

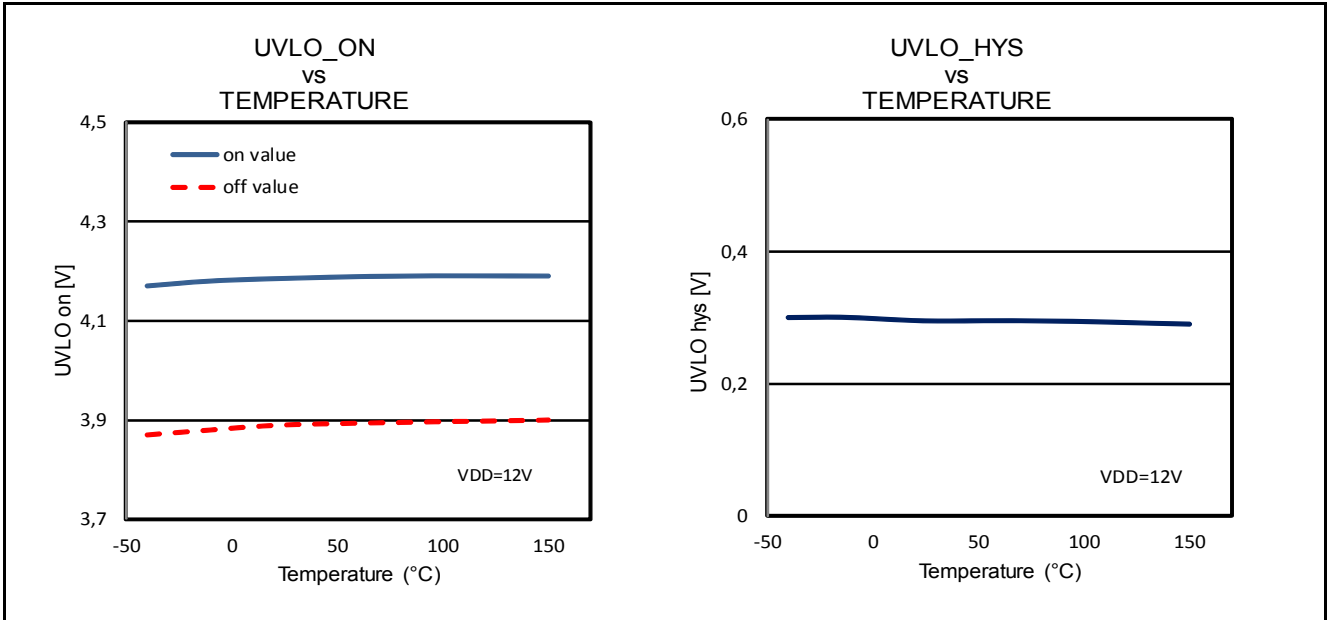

Figure 7-1 Undervoltage Logout

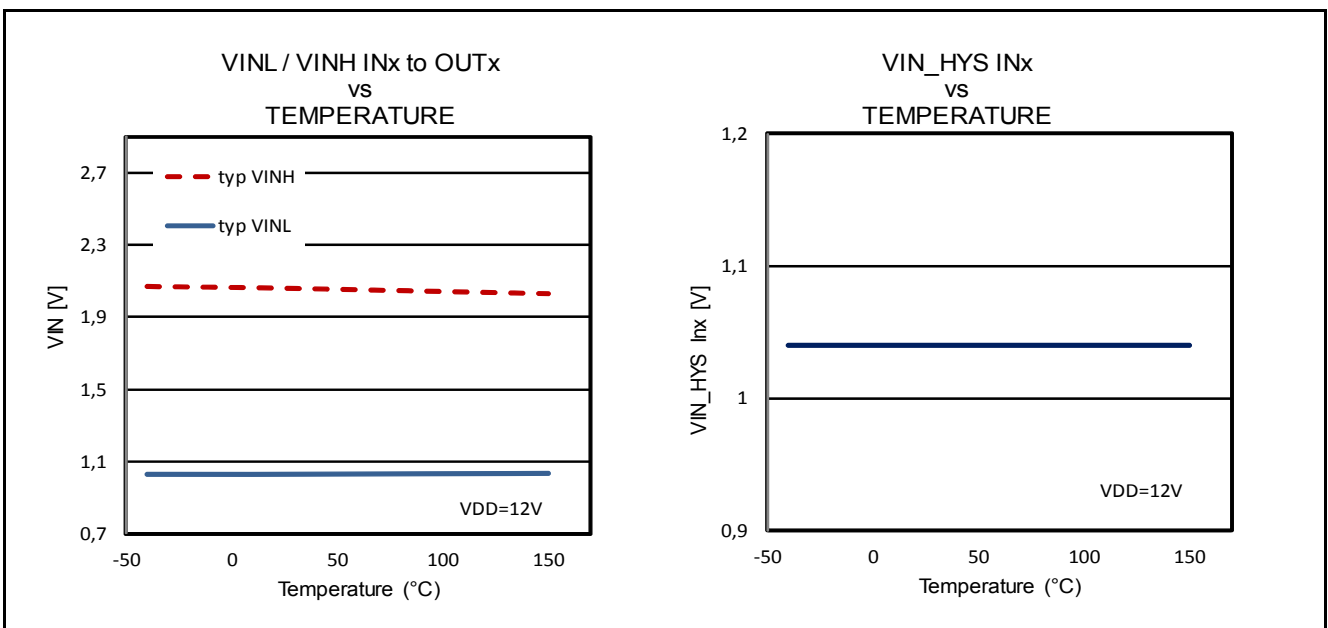

Figure 7-2 Input (INx) Characteristic

Typical Characteristics

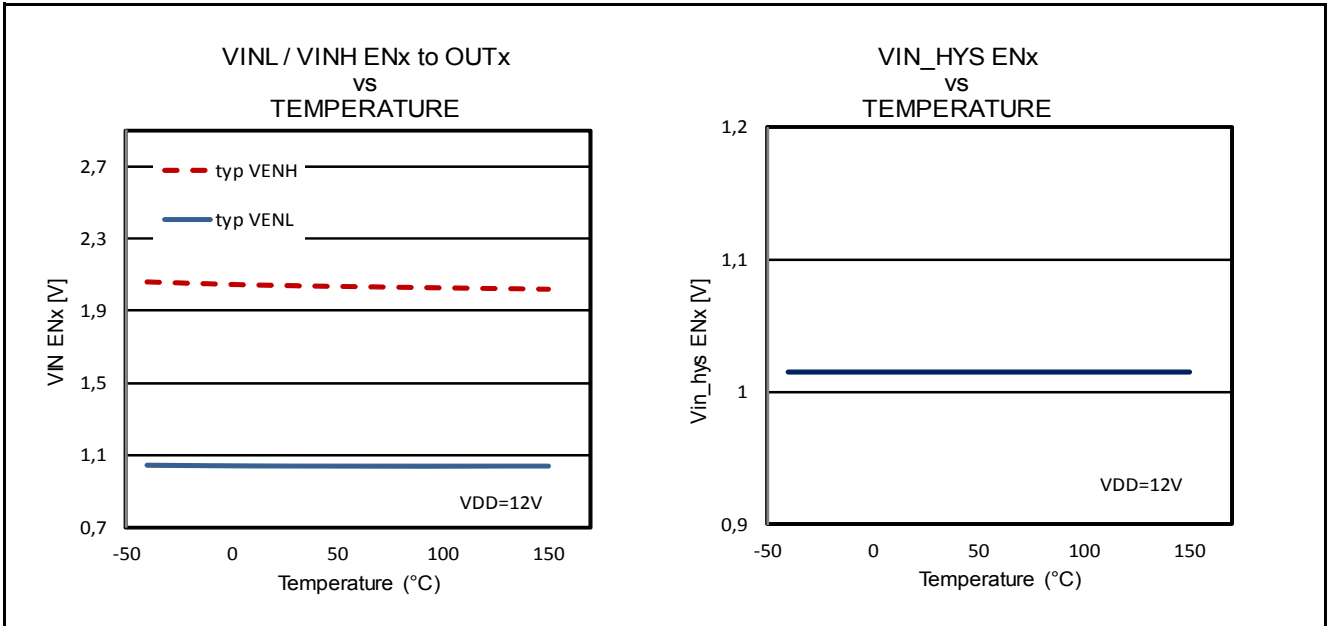

Figure 7-3 Input (ENx) Characteristic

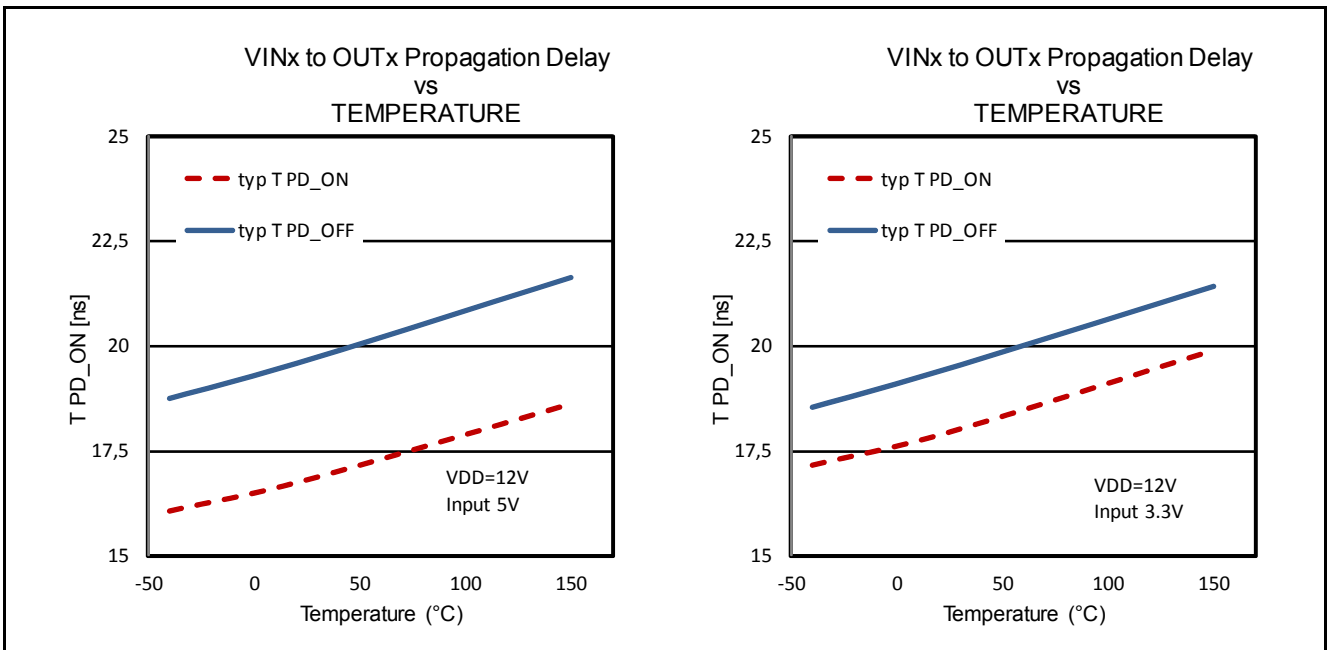

Figure 7-4 Propagation Delay (INx) on different input logic levels (see Figure 6-1)

Typical Characteristics

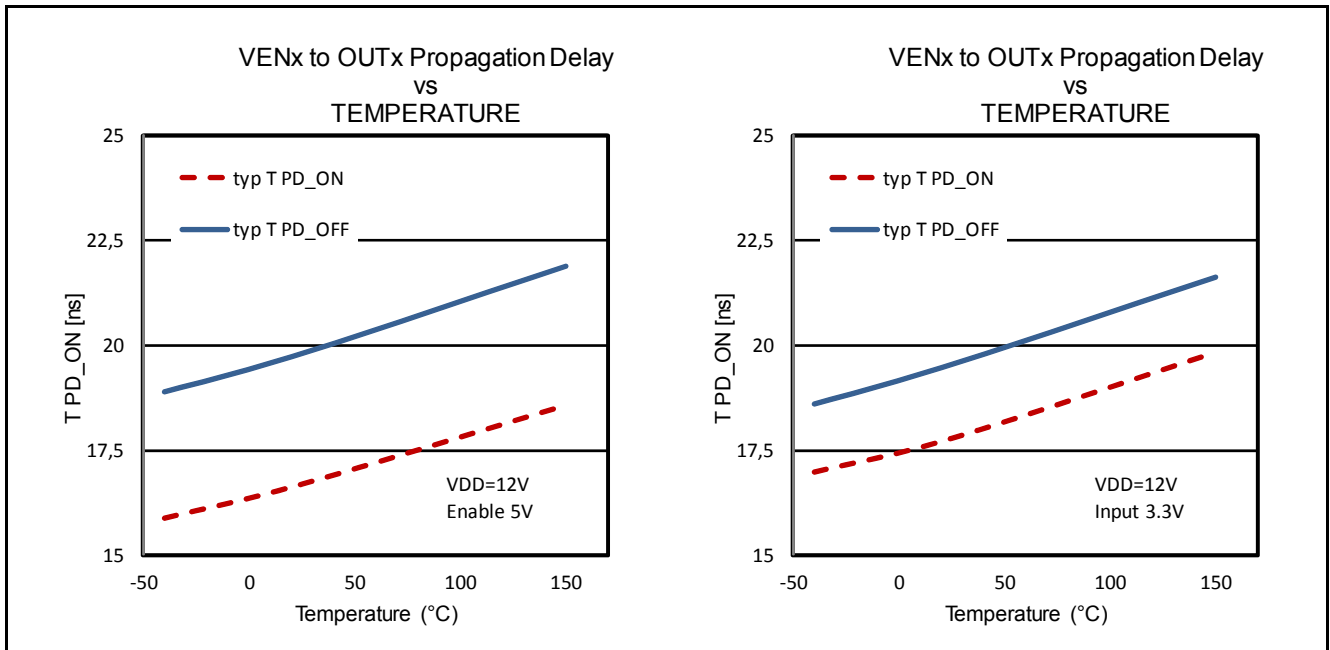

Figure 7-5 Propagation Delay (ENx) on different input logic levels (see Figure 6-1)

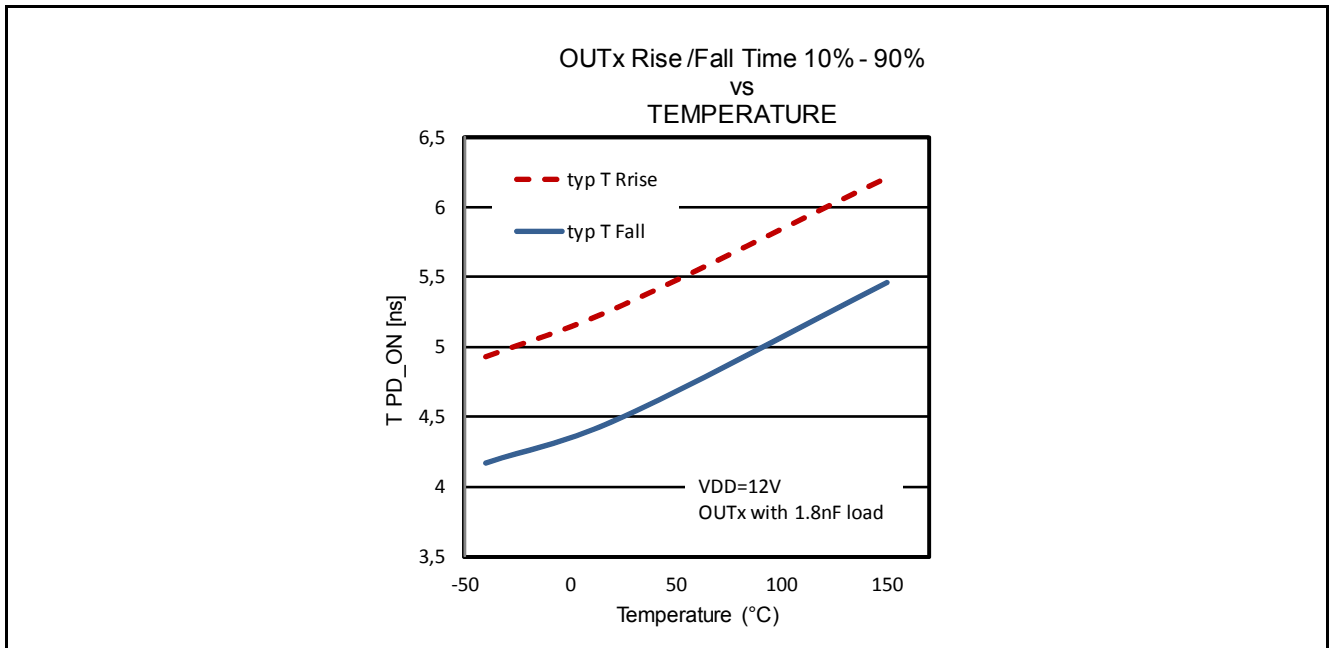

Figure 7-6 Rise / Fall Times with load on output (see Figure 6-1)

Outline Dimensions

8 Outline Dimensions

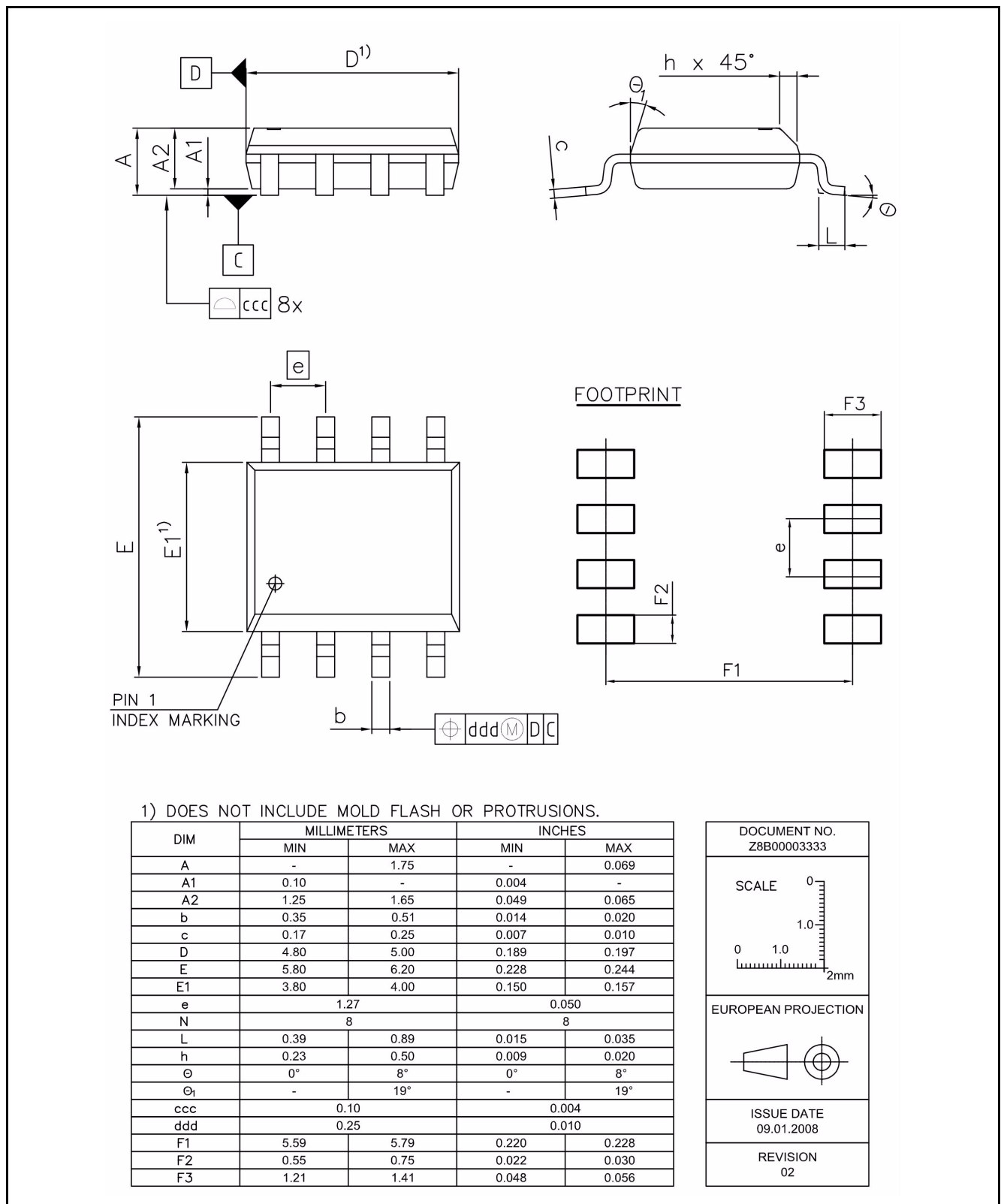

Figure 8-1 PG-DSO-8

Outline Dimensions

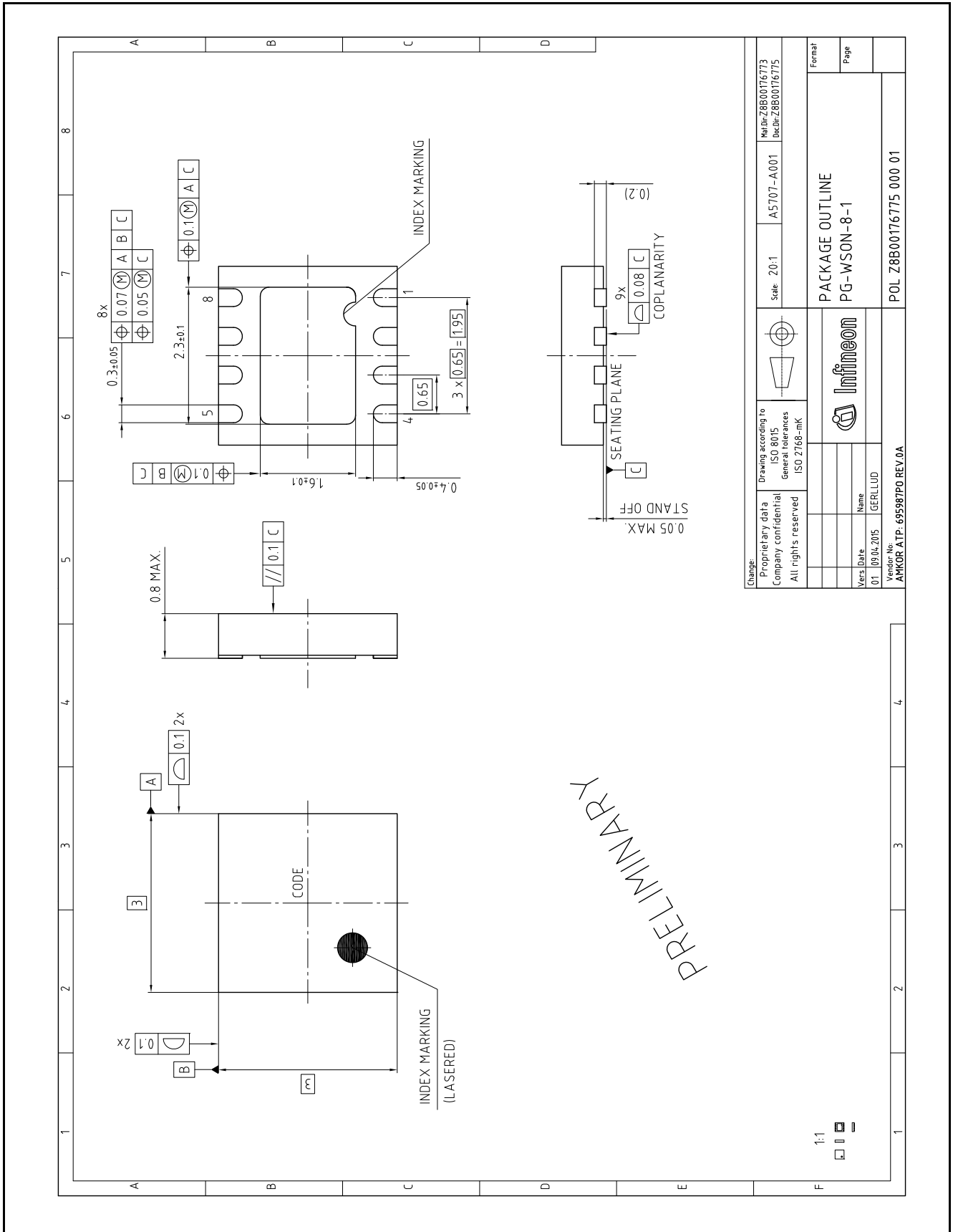

Figure 8-2 PG-WSON-8-1 (see notes)

Outline Dimensions

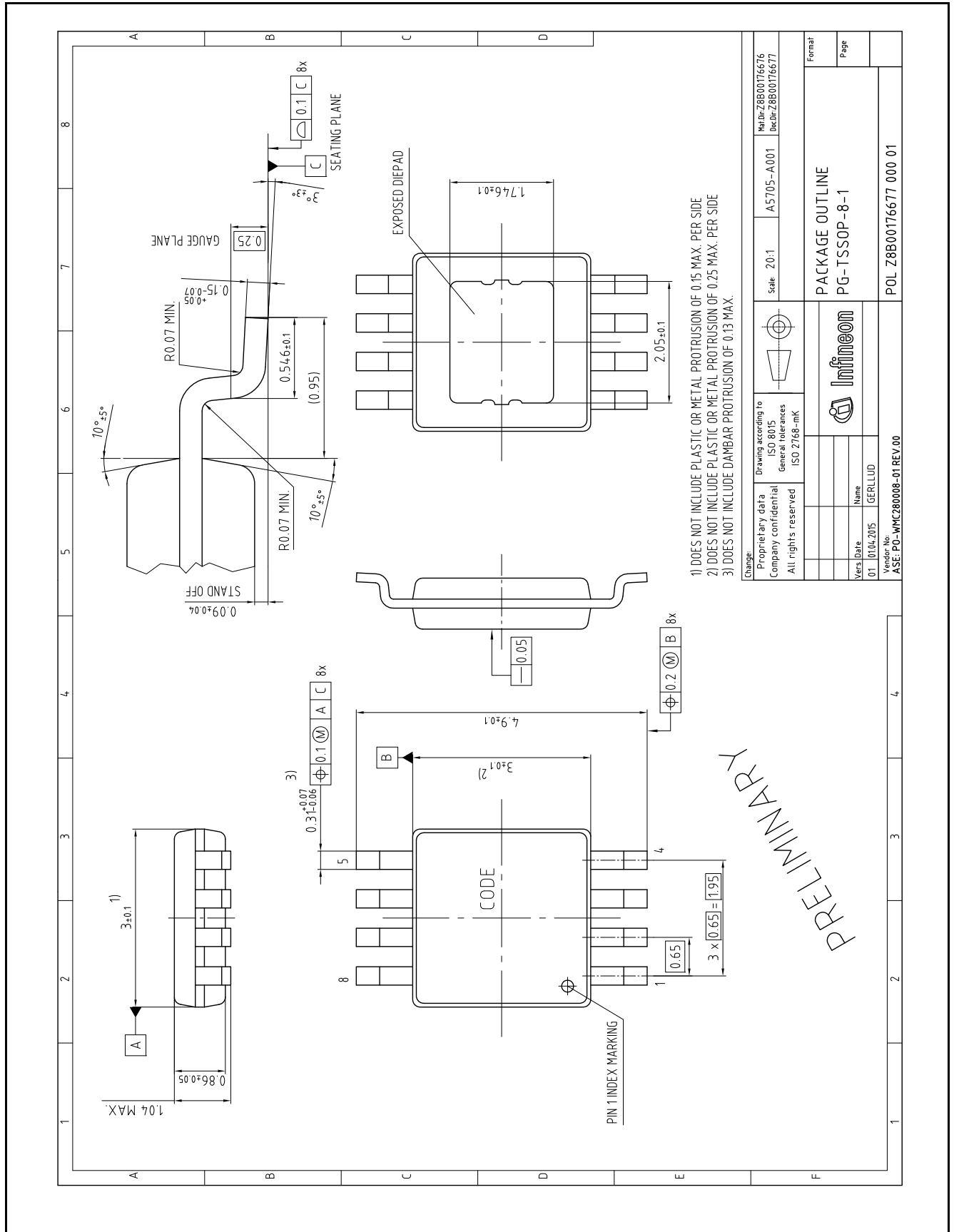

Figure 8-3 PG-TSSOP-8-1

---

**Outline Dimensions**

**Notes**

1. For further information on package types please go to:  
<http://www.infineon.com/cms/en/product/technology/packages/>.

#### Trademarks of Infineon Technologies AG

AURIX™, C166™, CanPAK™, CIPOS™, CIPURSE™, CoolMOS™, CoolSET™, CORECONTROL™, CROSSAVE™, DAVE™, DI-POL™, EasyPIM™, EconoBRIDGE™, EconoDUAL™, EconoPIM™, EconoPACK™, EiceDRIVER™, eupec™, FCOS™, HITFET™, HybridPACK™, I<sup>2</sup>RF™, ISOFACE™, IsoPACK™, MIPAQ™, ModSTACK™, my-d™, NovalithIC™, OptiMOS™, ORIGA™, POWERCODE™, PRIMARION™, PrimePACK™, PrimeSTACK™, PRO-SIL™, PROFET™, RASIC™, ReverSave™, SatRIC™, SIEGET™, SINDRION™, SIPMOS™, SmartLEWIS™, SOLID FLASH™, TEMPFET™, thinQ!™, TRENCHSTOP™, TriCore™.

#### Other Trademarks

Advance Design System™ (ADS) of Agilent Technologies, AMBA™, ARM™, MULTI-ICE™, KEIL™, PRIMECELL™, REALVIEW™, THUMB™, μVision™ of ARM Limited, UK. AUTOSAR™ is licensed by AUTOSAR development partnership. Bluetooth™ of Bluetooth SIG Inc. CAT-iq™ of DECT Forum. COLOSSUS™, FirstGPS™ of Trimble Navigation Ltd. EMV™ of EMVCo, LLC (Visa Holdings Inc.). EPCOS™ of Epcos AG. FLEXGO™ of Microsoft Corporation. FlexRay™ is licensed by FlexRay Consortium. HYPERTERMINAL™ of Hilgraeve Incorporated. IEC™ of Commission Electrotechnique Internationale. IrDA™ of Infrared Data Association Corporation. ISO™ of INTERNATIONAL ORGANIZATION FOR STANDARDIZATION. MATLAB™ of MathWorks, Inc. MAXIM™ of Maxim Integrated Products, Inc. MICROTEC™, NUCLEUS™ of Mentor Graphics Corporation. MIPI™ of MIPI Alliance, Inc. MIPS™ of MIPS Technologies, Inc., USA. muRata™ of MURATA MANUFACTURING CO., MICROWAVE OFFICE™ (MWO) of Applied Wave Research Inc., OmniVision™ of OmniVision Technologies, Inc. Openwave™ Openwave Systems Inc. RED HAT™ Red Hat, Inc. RFMD™ RF Micro Devices, Inc. SIRIUS™ of Sirius Satellite Radio Inc. SOLARIS™ of Sun Microsystems, Inc. SPANSION™ of Spansion LLC Ltd. Symbian™ of Symbian Software Limited. TAIYO YUDEN™ of Taiyo Yuden Co. TEAKLITE™ of CEVA, Inc. TEKTRONIX™ of Tektronix Inc. TOKO™ of TOKO KABUSHIKI KAISHA TA. UNIX™ of X/Open Company Limited. VERILOG™, PALLADIUM™ of Cadence Design Systems, Inc. VLYNQ™ of Texas Instruments Incorporated. VXWORKS™, WIND RIVER™ of WIND RIVER SYSTEMS, INC. ZETEX™ of Diodes Zetex Limited.

Last Trademarks Update 2011-11-11

[www.infineon.com](http://www.infineon.com)

**Edition 2015-05-12**

**Published by**

**Infineon Technologies AG**

**81726 Munich, Germany**

**© 2014 Infineon Technologies AG.**

**All Rights Reserved.**

**Do you have a question about any aspect of this document?**

**Email: [erratum@infineon.com](mailto:erratum@infineon.com)**

**Document reference**

**Doc\_Number**

#### Legal Disclaimer

The information given in this document shall in no event be regarded as a guarantee of conditions or characteristics. With respect to any examples or hints given herein, any typical values stated herein and/or any information regarding the application of the device, Infineon Technologies hereby disclaims any and all warranties and liabilities of any kind, including without limitation, warranties of non-infringement of intellectual property rights of any third party.

#### Information

For further information on technology, delivery terms and conditions and prices, please contact the nearest Infineon Technologies Office ([www.infineon.com](http://www.infineon.com)).

#### Warnings

Due to technical requirements, components may contain dangerous substances. For information on the types in question, please contact the nearest Infineon Technologies Office. Infineon Technologies components may be used in life-support devices or systems only with the express written approval of Infineon Technologies, if a failure of such components can reasonably be expected to cause the failure of that life-support device or system or to affect the safety or effectiveness of that device or system. Life support devices or systems are intended to be implanted in the human body or to support and/or maintain and sustain and/or protect human life. If they fail, it is reasonable to assume that the health of the user or other persons may be endangered.