

Fig1. MEASURING METHOD

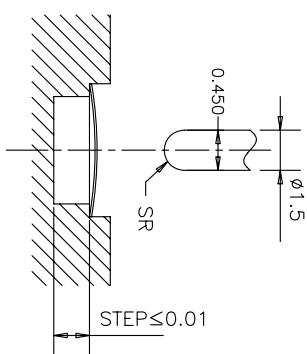

Fig2. OPERATING PERFORMANCE

NOTES:
 1. ALL THE OPERATING PERFORMANCE SPEC. IN BELLOW TABLE SHOULD BE MET. THE MEASURE METHOD IS SHOWN AS FIG.1. OPERATE THE DOME 10 TIMES BEFORE MEASURING.

REV	ECN NO.	APPD
A	HC080001	ZO
B	HC090052	ZO



- 1) TEST SPEED : 140 SPM
- 2) TEST FORCE : 1.5*F_p
- 3) MATERIAL : ALUMINIUM.
- 4) AFTER LIFE TEST, C/R DECREASE 30% MAX.
- 5) OBVIOUS BURR, SCRATCHES, CRACKES IS FORBIDDEN.
- 6) DIMENSIONS MARKED ∇ SHOULD BE CHECKED BY O.C. AND P.E.
- 7) DIMENSIONING SHALL BE INTERPRETED PER ANSI Y14.5M-1982.
- 8) HARMFUL MATERIAL CONTROL PLEASE FOLLOW DOC."HY-QW-02"
- 9) PART PERFORMANCE TABLE

PART NAME	P.F(gf)	C/R(%)	MAT'L	FINISH	STEP(mm)
824-0000-***	CP±20	60±15	SUS301	Ag PLATING	0

CP:
 060-----60gf
 080-----80gf
 100-----100gf
 120-----120gf

X. ± 0.2	X.* ± 0.2*	UNITS	MM	NAME(NTENDED USE)	HON YUAN
.X ± 0.1	.X* ± 0.1*	MAT'L		METAL DOME FOR TACT SWITCH	HON YUAN PRECISION IND. CO.,LTD. SHENZHEN, CHINA, R.O.C.
.XX ± 0.05	.XX* ± 0.01*	FINISH		PART NO.(NTENDED USE)	
.XXX ± 0.03	.XXX* ± 0.005*			N/A	
APPD: ZO 4/06'09 CHKD: PRIOUOM 4/06'09 DR: ZO 4/06'09				TITLE: CUSTOMER DRAWING DWG NO.: 824-0000-000	
THESE DRAWINGS AND SPECIFICATIONS ARE THE PROPERTY OF HON YUAN PRECISION IND. CO., LTD. AND SHALL NOT BE REPRODUCED, COPIED OR USED IN ANY MANNER WITHOUT THE PRIOR WRITTEN CONSENT OF HON YUAN PRECISION IND. CO., LTD.				SCALE SHEET REV. 1/1 1/1 B	