Three-Wire Serial EEPROM 16-Kbit (2,048 x 8 or 1,024 x 16)

Features

- Low-Voltage Operation:
 - $V_{CC} = 1.8V$ to $5.5V$
 - $V_{CC} = 2.7V$ to $5.5V$
- User-Selectable Internal Organized as 2,048 x 8 (16K) or 1,024 x 16 (16K)
- Industrial Temperature Range: $-40^{\circ}C$ to $+85^{\circ}C$
- Three-Wire Serial Interface
- Sequential Read Operation
- Schmitt Trigger, Filtered Inputs for Noise Suppression
- 2 MHz Clock Rate (5V)
- Self-Timed Write Cycle within 10 ms Maximum
- High Reliability:
 - Endurance: 1,000,000 write cycles
 - Data retention: 100 years
- Green Package Options (Lead-free/Halide-free/RoHS compliant)

Packages

- 8-Lead SOIC, 8-Lead TSSOP, 8-Pad UDFN and 8-Lead PDIP

Table of Contents

Features.....	1
Packages.....	1
1. Package Types (not to scale).....	4
2. Pin Descriptions.....	5
2.1. Chip Select (CS).....	5
2.2. Serial Data Clock (SK).....	5
2.3. Serial Data Input (DI).....	5
2.4. Serial Data Output (DO).....	5
2.5. Ground (GND).....	5
2.6. Internal Organization (ORG).....	6
2.7. Device Power Supply (V_{CC}).....	6
3. Description.....	7
3.1. Block Diagram.....	7
4. Electrical Characteristics.....	8
4.1. Absolute Maximum Ratings.....	8
4.2. DC and AC Operating Range.....	8
4.3. DC Characteristics.....	8
4.4. AC Characteristics.....	9
4.5. Synchronous Data Timing.....	10
4.6. Electrical Specifications.....	11
5. Device Commands and Addressing.....	12
5.1. READ.....	12
5.2. Erase/Write Enable (EWEN).....	13
5.3. Erase/Write Disable (EWDS).....	13
5.4. ERASE.....	14
5.5. WRITE.....	14
5.6. Write All (WRAL).....	15
5.7. Erase All (ERAL).....	15
6. Packaging Information.....	17
6.1. Package Marking Information.....	17
7. Revision History.....	28
The Microchip Website.....	29
Product Change Notification Service.....	29
Customer Support.....	29
Product Identification System.....	30
Microchip Devices Code Protection Feature.....	30

Legal Notice.....	31
Trademarks.....	31
Quality Management System.....	32
Worldwide Sales and Service.....	33

1. Package Types (not to scale)**8-lead PDIP/SOIC/TSSOP**

(Top View)

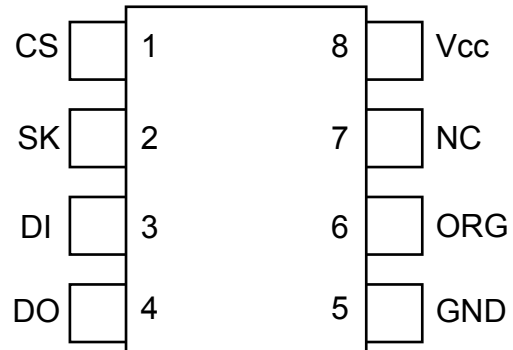
**8-pad UDFN**

(Top View)

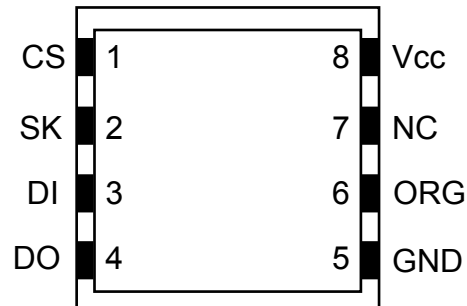

2. Pin Descriptions

The descriptions of the pins are listed in [Table 2-1](#).

Table 2-1. Pin Function Table

Name	8-Lead PDIP	8-Lead SOIC	8-Lead TSSOP	8-Pad UDFN ⁽¹⁾	Function
CS	1	1	1	1	Chip Select
SK	2	2	2	2	Serial Data Clock
DI	3	3	3	3	Serial Data Input
DO	4	4	4	4	Serial Data Output
GND	5	5	5	5	Ground
ORG	6	6	6	6	Internal Organization
NC	7	7	7	7	No Connect
V _{CC}	8	8	8	8	Device Power Supply

Note:

1. The exposed pad on this package can be connected to GND or left floating.

2.1 Chip Select (CS)

The Chip Select (CS) pin is used to control device selection. The AT93C86A is selected when the CS pin is high. When the device is not selected, data will not be accepted via the Serial Data Input (DI) pin, and the Serial Output (DO) pin will remain in a high-impedance state.

2.2 Serial Data Clock (SK)

The Serial Data Clock (SK) pin is used to synchronize the communication between a master and the AT93C86A. Instructions, addresses or data present on the Serial Data Input (DI) pin is latched in on the rising edge of SK, while output on the Serial Data Output (DO) pin is also clocked out on the rising edge of SK.

2.3 Serial Data Input (DI)

The Serial Data Input (DI) pin is used to transfer data into the device. It receives instructions, addresses and data. Data is latched on the rising edge of the Serial Data Clock (SK).

2.4 Serial Data Output (DO)

The Serial Data Output (DO) pin is used to transfer data out of the AT93C86A. During a read sequence, data is shifted out on this pin after the rising edge of the Serial Data Clock (SK).

This pin also outputs the Ready/Busy status of the part if CS is brought high after being low for a minimum of t_{cs} and an erase or write operation has been initiated.

2.5 Ground (GND)

The ground reference for the power supply. The Ground (GND) pin should be connected to the system ground.

2.6 Internal Organization (ORG)

The Internal Organization (ORG) pin is used to select between the x16 or x8 memory organizations of the device. When the ORG pin is tied to V_{CC} , the x16 memory organization is selected. When the ORG pin is tied to V_{SS} , the x8 memory organization is selected.

If the ORG pin is left unconnected and the application does not load the input beyond the capability of the internal 1 M Ω pull-up resistor, then the x16 organization is selected.

2.7 Device Power Supply (V_{CC})

The Device Power Supply (V_{CC}) pin is used to supply the source voltage to the device. Operations at invalid V_{CC} voltages may produce spurious results and should not be attempted.

3. Description

The AT93C86A provides 16,384 bits of Serial Electrically Erasable and Programmable Read-Only Memory (EEPROM) organized as 1,024 words of 16 bits each (when the ORG pin is connected to V_{CC}) and 2,048 words of 8 bits each (when the ORG pin is tied to ground). The device is optimized for use in many industrial and commercial applications where low-power and low-voltage operations are essential. The AT93C86A is available in space-saving 8-lead SOIC, 8-lead TSSOP, 8-pad UDFN and 8-lead PDIP packages. All packages operate from 1.8V to 5.5V or from 2.7V to 5.5V.

The AT93C86A is enabled through the Chip Select (CS) pin and accessed via a three-wire serial interface consisting of Data Input (DI), Data Output (DO), and Serial Data Clock (SK). Upon receiving a `READ` instruction at DI, the address is decoded, and the data is clocked out serially on the DO pin. The write cycle is completely self-timed, and no separate erase cycle is required before write. The write cycle is only enabled when the part is in the Erase/Write Enable state. When CS is brought high following the initiation of a write cycle, the DO pin outputs the Ready/Busy status of the part.

3.1 Block Diagram

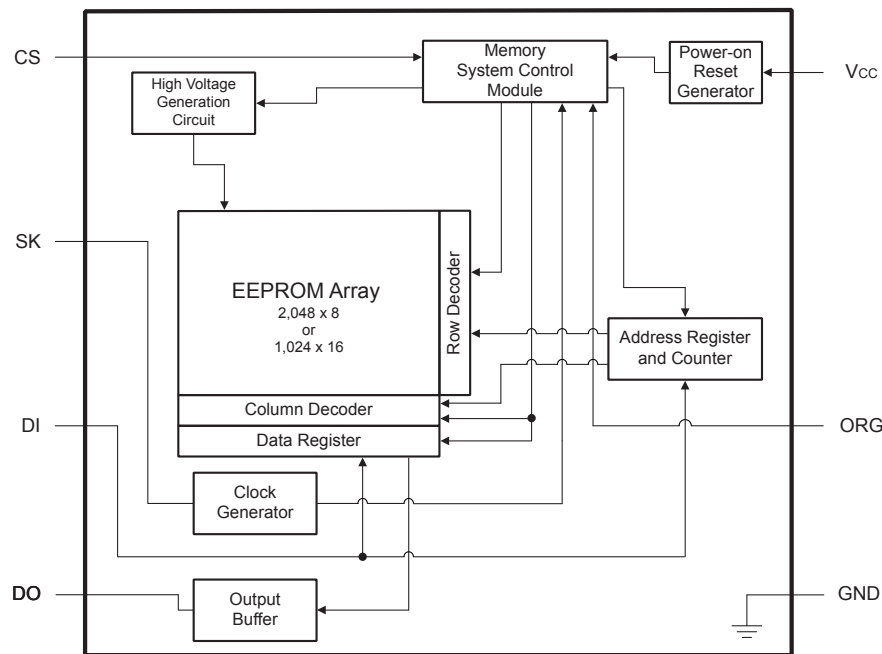

Note:

1. When the ORG pin is connected to V_{CC} , the x16 organization is selected. When it is connected to ground, the x8 organization is selected. If the ORG pin is left unconnected, and the application does not load the input beyond the capability of the 10 $M\Omega$ pull-up resistor, then the x16 organization is selected.

4. Electrical Characteristics

4.1 Absolute Maximum Ratings

Temperature under bias	-55°C to +125°C
Storage temperature	-65°C to +150°C
V _{CC}	6.25V
Voltage on any pin with respect to ground	-1.0V to +7.0V
DC output current	5.0 mA
ESD protection	2 kV

Note: Stresses above those listed under “Absolute Maximum Ratings” may cause permanent damage to the device. This is a stress rating only and functional operation of the device at these or any other conditions above those indicated in the operation listings of this specification is not implied. Exposure to absolute maximum rating conditions for extended periods may affect device reliability.

4.2 DC and AC Operating Range

Table 4-1. DC and AC Operating Range

AT93C86A		
Operating Temperature (Case)	Industrial Temperature Range	-40°C to +85°C
V _{CC} Power Supply	Low-Voltage Grade	1.8V to 5.5V

4.3 DC Characteristics

Table 4-2. DC Characteristics⁽¹⁾

Parameter	Symbol	Minimum	Typical	Maximum	Units	Test Conditions
Supply Voltage	V _{CC1}	1.8	—	5.5	V	
Supply Voltage	V _{CC2}	2.7	—	5.5	V	
Supply Voltage	V _{CC3}	4.5	—	5.5	V	
Supply Current	I _{CC1}	—	0.5	2.0	mA	V _{CC} = 5.0V, Read at 1 MHz
Supply Current	I _{CC2}	—	0.5	2.0	mA	V _{CC} = 5.0V, Write at 1 MHz
Standby Current (1.8V Option)	I _{SB1}	—	0.4	1.0	μA	V _{CC} = 1.8V, CS = 0V
Standby Current (2.7V Option)	I _{SB2}	—	6.0	10.0	μA	V _{CC} = 2.7V, CS = 0V
Standby Current (5.0V Option)	I _{SB3}	—	10.0	15.0	μA	V _{CC} = 5.0V, CS = 0V
Input Leakage Current	I _{IL}	—	0.1	3.0	μA	V _{IN} = 0 to V _{CC}
Output Leakage Current	I _{LO}	—	0.1	3.0	μA	V _{IN} = 0 to V _{CC}

.....continued

Parameter	Symbol	Minimum	Typical	Maximum	Units	Test Conditions
Input Low-Voltage	V_{IL1}	-0.6	—	0.8	V	$2.7V \leq V_{CC} \leq 5.5V$ (Note 2)
Input High-Voltage	V_{IH1}	2.0	—	$V_{CC} + 1$	V	$2.7V \leq V_{CC} \leq 5.5V$ (Note 2)
Input Low-Voltage	V_{IL2}	-0.6	—	$V_{CC} \times 0.3$	V	$1.8V \leq V_{CC} \leq 2.7V$ (Note 2)
Input High-Voltage	V_{IH2}	$V_{CC} \times 0.7$	—	$V_{CC} + 1$	V	$1.8V \leq V_{CC} \leq 2.7V$ (Note 2)
Output Low-Voltage	V_{OL1}	—	—	0.4	V	$2.7V \leq V_{CC} \leq 5.5V$, $I_{OL} = 2.1 \text{ mA}$
Output High-Voltage	V_{OH1}	2.4	—	—	V	$2.7V \leq V_{CC} \leq 5.5V$, $I_{OH} = -0.4 \text{ mA}$
Output Low-Voltage	V_{OL2}	—	—	0.2	V	$1.8V \leq V_{CC} \leq 2.7V$, $I_{OL} = 0.15 \text{ mA}$
Output High-Voltage	V_{OH2}	$V_{CC} - 0.2$	—	—	V	$1.8V \leq V_{CC} \leq 2.7V$, $I_{OH} = -100 \mu\text{A}$

Note:

1. Applicable over recommended operating range from: $T_A = -40^\circ\text{C}$ to $+85^\circ\text{C}$, $V_{CC} = 1.8V$ to $5.5V$ (unless otherwise noted).
2. V_{IL} min and V_{IH} max are reference only and are not tested.

4.4 AC Characteristics

Table 4-3. AC Characteristics⁽¹⁾

Parameter	Symbol	Minimum	Typical	Maximum	Units	Test Conditions
Clock Frequency, SK	f_{SK}	0	—	2	MHz	$4.5V \leq V_{CC} \leq 5.5V$
		0	—	1	MHz	$2.7V \leq V_{CC} \leq 5.5V$
		0	—	250	kHz	$1.8V \leq V_{CC} \leq 5.5V$
High Time, SK	t_{SKH}	250	—	—	ns	$2.7V \leq V_{CC} \leq 5.5V$
		1000	—	—	ns	$1.8V \leq V_{CC} \leq 5.5V$
Low Time, SK	t_{SKL}	250	—	—	ns	$2.7V \leq V_{CC} \leq 5.5V$
		1000	—	—	ns	$1.8V \leq V_{CC} \leq 5.5V$
Minimum CS Low Time	t_{CS}	250	—	—	ns	$2.7V \leq V_{CC} \leq 5.5V$
		1000	—	—	ns	$1.8V \leq V_{CC} \leq 5.5V$
CS Setup Time	t_{CSS}	50	—	—	ns	$2.7V \leq V_{CC} \leq 5.5V$, Relative to SK
		200	—	—	ns	$1.8V \leq V_{CC} \leq 5.5V$, Relative to SK
DI Setup Time	t_{DIS}	100	—	—	ns	$2.7V \leq V_{CC} \leq 5.5V$, Relative to SK
		400	—	—	ns	$1.8V \leq V_{CC} \leq 5.5V$, Relative to SK
CS Hold Time	t_{CSH}	0	—	—	ns	Relative to SK

.....continued

Parameter	Symbol	Minimum	Typical	Maximum	Units	Test Conditions
DI Hold Time	t_{DIH}	100	—	—	ns	$2.7V \leq V_{CC} \leq 5.5V$, Relative to SK
		400	—	—	ns	$1.8V \leq V_{CC} \leq 5.5V$, Relative to SK
Output Delay to 1	t_{PD1}	—	—	250	ns	$2.7V \leq V_{CC} \leq 5.5V$
		—	—	1000	ns	$1.8V \leq V_{CC} \leq 5.5V$
Output Delay to 0	t_{PD0}	—	—	250	ns	$2.7V \leq V_{CC} \leq 5.5V$
		—	—	1000	ns	$1.8V \leq V_{CC} \leq 5.5V$
CS to Status Valid	t_{SV}	—	—	250	ns	$2.7V \leq V_{CC} \leq 5.5V$
		—	—	1000	ns	$1.8V \leq V_{CC} \leq 5.5V$
CS to DO in High-impedance	t_{DF}	—	—	150	ns	$2.7V \leq V_{CC} \leq 5.5V$, CS = V_{IL}
		—	—	400	ns	$1.8V \leq V_{CC} \leq 5.5V$, CS = V_{IL}
Write Cycle Time	t_{WP}	0.1	3	10	ms	$1.8V \leq V_{CC} \leq 5.5V$

Note:

- Applicable over recommended operating range from $T_A = -40^\circ C$ to $+85^\circ C$, $V_{CC} =$ As Specified, $C_L = 1$ TTL Gate and 100 pF (unless otherwise noted).

4.5 Synchronous Data Timing

Figure 4-1. Synchronous Data Timing

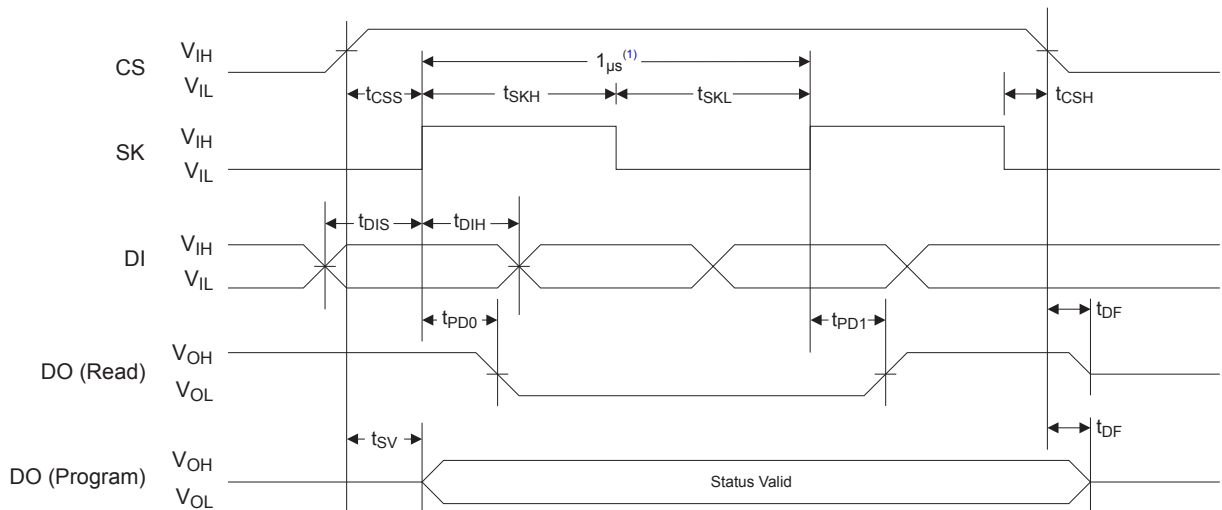

Note:

- This is the minimum SK period.

4.6 Electrical Specifications

4.6.1 Power-Up Requirements and Reset Behavior

During a power-up sequence, the V_{CC} supplied to the AT93C86A should monotonically rise from GND to the minimum V_{CC} level, as specified in Table 4-1, with a slew rate no faster than 0.1 V/ μ s.

4.6.1.1 Device Reset

To prevent inadvertent write operations or any other spurious events from occurring during a power-up sequence, the AT93C86A includes a Power-on Reset (POR) circuit. Upon power-up, the device will not respond to any commands until the V_{CC} level crosses the internal voltage threshold (V_{POR}) that brings the device out of Reset and into Standby mode.

The system designer must ensure the instructions are not sent to the device until the V_{CC} supply has reached a stable value greater than or equal to the minimum V_{CC} level. Additionally, once the V_{CC} is greater than or equal to the minimum V_{CC} level, the bus master must wait at least t_{PUP} before sending the first command to the device. See Power-up Conditions⁽¹⁾ for the values associated with these power-up parameters.

Table 4-4. Power-up Conditions⁽¹⁾

Symbol	Parameter	Min.	Max.	Units
t_{PUP}	Time required after V_{CC} is stable before the device can accept commands	100	—	μ s
V_{POR}	Power-on Reset Threshold Voltage	—	1.5	V
t_{POFF}	Minimum time at $V_{CC} = 0V$ between power cycles	500	—	ms

Note:

- These parameters are characterized but they are not 100% tested in production.

If an event occurs in the system where the V_{CC} level supplied to the AT93C86A drops below the maximum V_{POR} level specified, it is recommended that a full power cycle sequence be performed by first driving the V_{CC} pin to GND, waiting at least the minimum t_{POFF} time and then performing a new power-up sequence in compliance with the requirements defined in this section.

4.6.2 Pin Capacitance

Table 4-5. Pin Capacitance⁽¹⁾

Symbol	Test Condition	Max.	Units	Conditions
C_{OUT}	Output Capacitance (DO)	5	pF	$V_{OUT} = 0V$
C_{IN}	Input Capacitance (CS, SK, DI, ORG)	5	pF	$V_{IN} = 0V$

Note:

- This parameter is characterized but is not 100% tested in production.

4.6.3 EEPROM Cell Performance Characteristics

Table 4-6. EEPROM Cell Performance Characteristics

Operation	Test Condition	Min.	Max.	Units
Write Endurance ⁽¹⁾	$T_A = 25^\circ C, V_{CC} = 5.0V$	1,000,000	—	Write Cycles
Data Retention ⁽¹⁾	$T_A = 55^\circ C$	100	—	Years

Note:

- Performance is determined through characterization and the qualification process.

5. Device Commands and Addressing

The AT93C86A is accessed via a simple and versatile three-wire serial communication interface. Device operation is controlled by seven instructions issued by the Host processor. A valid instruction starts with a rising edge of CS and consists of a Start bit (SB), followed by the appropriate opcode, and the desired memory address location.

Table 5-1. AT93C86A Instruction Set

Instruction	SB	Opcode	Address		Data		Comments
			X8 ⁽¹⁾	X16 ⁽¹⁾	X8	X16	
READ	1	10	A ₁₀ -A ₀	A ₉ -A ₀			Reads data stored in memory at specified address.
EWEN	1	00	11XXXXXXXXXX	11XXXXXXXXXX			Write Enable must precede all programming modes.
ERASE	1	11	A ₁₀ -A ₀	A ₉ -A ₀			Erases memory location A _N -A ₀ .
WRITE	1	01	A ₁₀ -A ₀	A ₉ -A ₀	D ₇ -D ₀	D ₁₅ -D ₀	Writes memory location A _N -A ₀ .
ERAL	1	00	10XXXXXXXXXX	10XXXXXXXXXX			Erases all memory locations. Valid only at V _{CC3} . See Table 4-2 .
WRAL	1	00	01XXXXXXXXXX	01XXXXXXXXXX	D ₇ -D ₀	D ₁₅ -D ₀	Writes all memory locations. Valid only at V _{CC3} . See Table 4-2 .
EWDS	1	00	00XXXXXXXXXX	00XXXXXXXXXX			Disables all programming instructions.

Note:

- The 'x' in the address field represents a "don't care" bit and must be sent to the device.

Table 5-2. Organization Key for Timing Diagrams

I/O	AT93C86A (16K)	
	x8	x16
A _N	A ₁₀	A ₉
D _N	D ₇	D ₁₅

5.1 READ

The READ instruction contains the address code for the memory location to be read. After the instruction and address are decoded, data from the selected memory location is available at the DO pin. Output data changes are synchronized with the rising edges of the SK pin. The AT93C86A supports sequential read operations. The device will automatically increment the internal Address Pointer and clock out the next memory location as long as Chip Select (CS) is held high. In this case, the dummy bit (Logic '0') will not be clocked out between memory locations, thus allowing for a continuous stream of data to be read.

Note: A dummy bit (logic '0') precedes the initial 8-bit or 16-bit data output string.

Figure 5-1. READ Timing

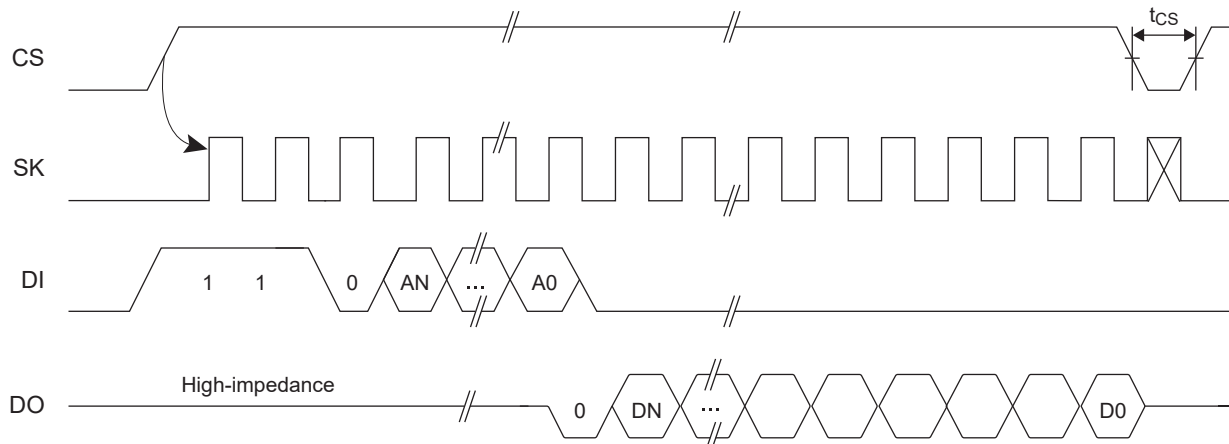

5.2 Erase/Write Enable (EWEN)

To ensure data integrity, the part automatically goes into the Erase/Write Disable (EWDS) state when power is first applied. An Erase/Write Enable (EWEN) instruction must be executed first before any programming instructions can be carried out.

Note: Once in the write enabled state, programming remains enabled until an EWDS instruction is executed, or V_{CC} power is removed from the part.

Figure 5-2. EWEN Timing

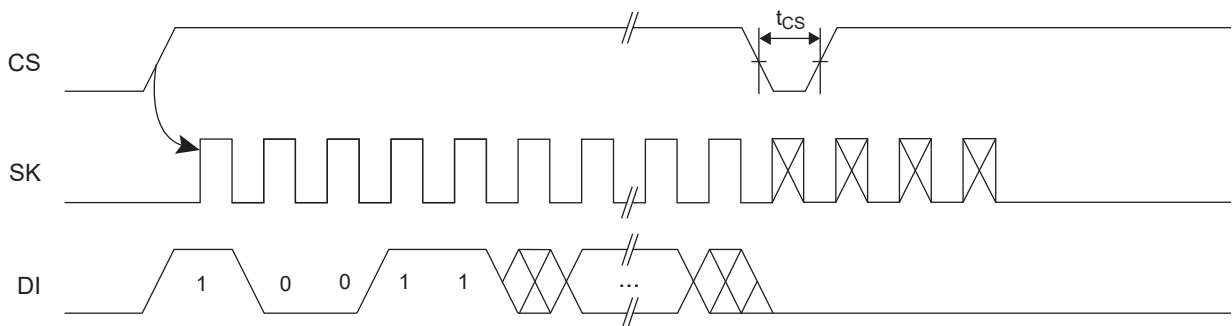

5.3 Erase/Write Disable (EWDS)

To protect against accidental data disturbance, the Erase/Write Disable (EWDS) instruction disables all programming modes and should be executed after all programming operations. The operation of the READ instruction is independent of both the EWEN and EWDS instructions and can be executed at any time.

Figure 5-3. EWDS Timing

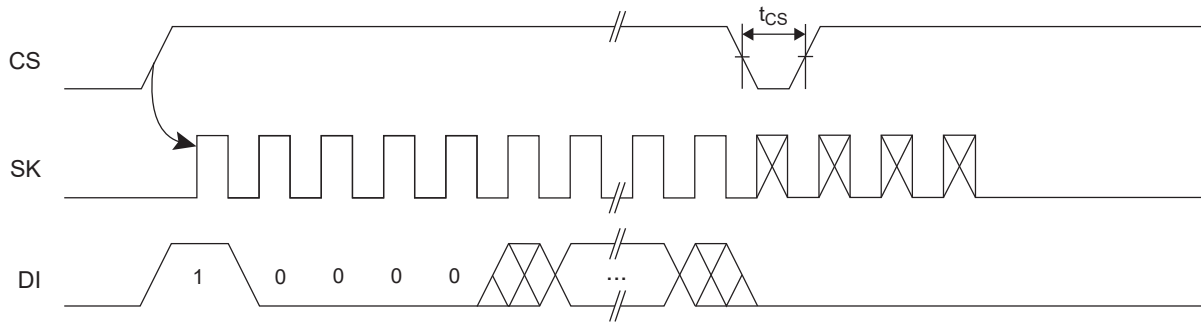

5.4 ERASE

The `ERASE` instruction programs all bits in the specified memory location to the logic '1' state. The self-timed erase cycle starts once the `ERASE` instruction and address are decoded. The DO pin outputs the Ready/Busy status of the part if CS is brought high after being kept low for a minimum of t_{CS} . A logic '1' at the DO pin indicates that the selected memory location has been erased, and the part is ready for another instruction.

Figure 5-4. ERASE Timing

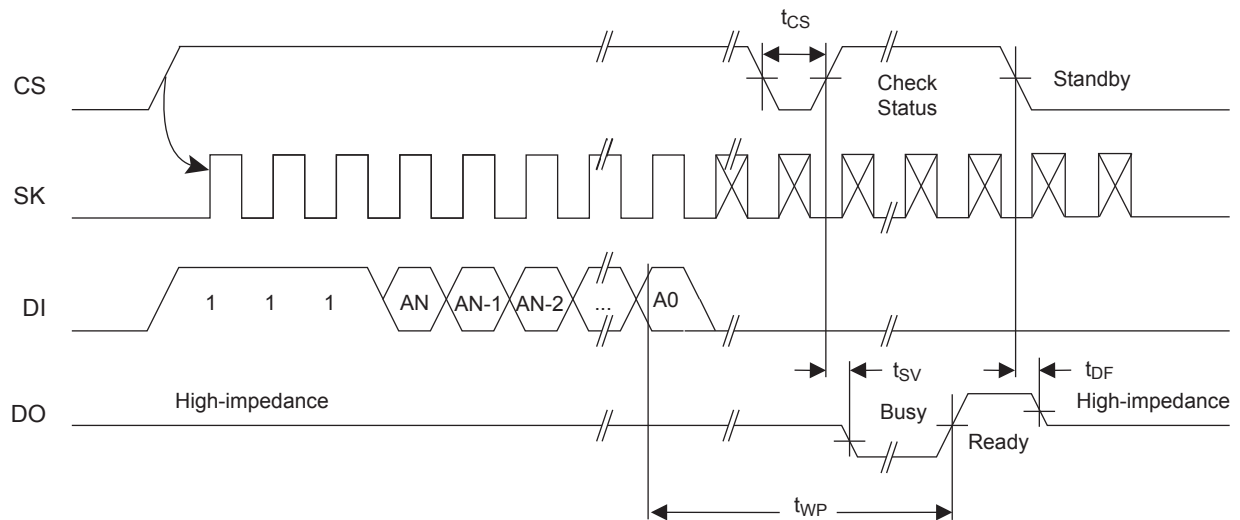

5.5 WRITE

The `WRITE` instruction contains the 8 bits or 16 bits of data to be written into the specified memory location. The self-timed programming cycle, t_{WP} , starts after the last bit of data is received at DI pin. The DO pin outputs the Ready/Busy status of the part if CS is brought high after being kept low for a minimum of t_{CS} . A logic '0' at DO indicates that programming is still in progress. A logic '1' indicates that the memory location at the specified address has been written with the data pattern contained in the instruction, and the part is ready for further instructions. A Ready/Busy status cannot be obtained if CS is brought high after the end of the self-timed programming cycle, t_{WP} .

Figure 5-5. WRITE Timing

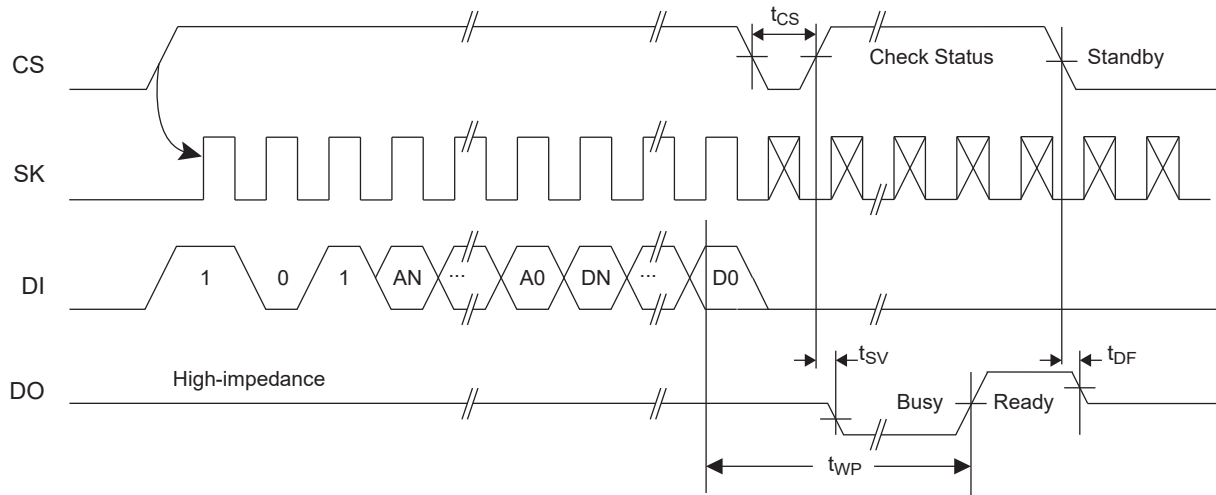

5.6 Write All (WRAL)

The Write All ($WRAL$) instruction programs all memory locations with the data patterns specified in the instruction. The DO pin outputs the Ready/Busy status of the part if CS is brought high after being kept low for a minimum of t_{CS} .

Note: The $WRAL$ instruction is valid only at V_{CC3} (see Table 4-2).

Figure 5-6. WRAL Timing

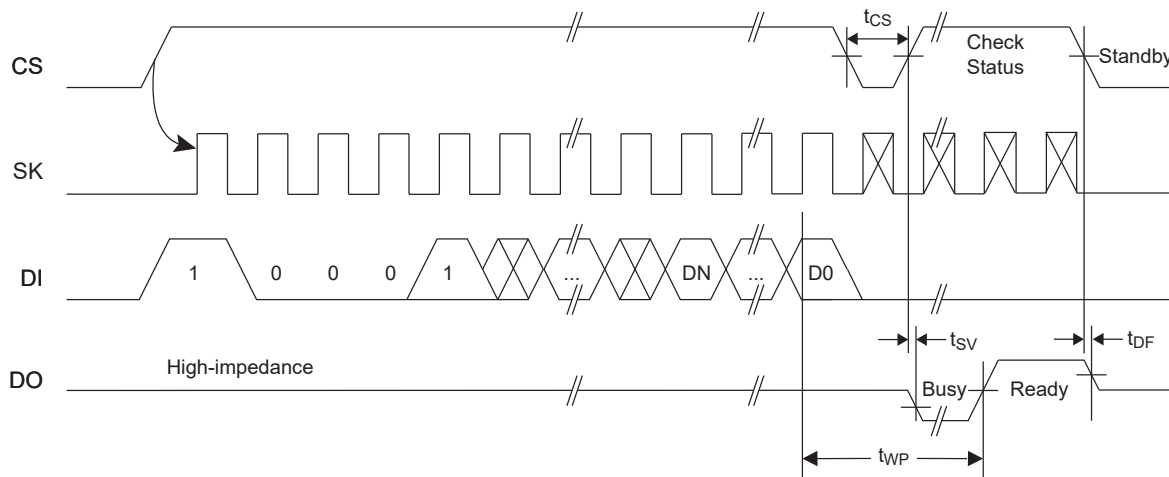

5.7 Erase All (ERAL)

The Erase All ($ERAL$) instruction programs every bit in the memory array to the logic '1' state and is primarily used for testing purposes. The DO pin outputs the Ready/Busy status of the part if CS is brought high after being kept low for a minimum of t_{CS} .

Note: The $ERAL$ instruction is valid only at V_{CC3} (see Table 4-2).

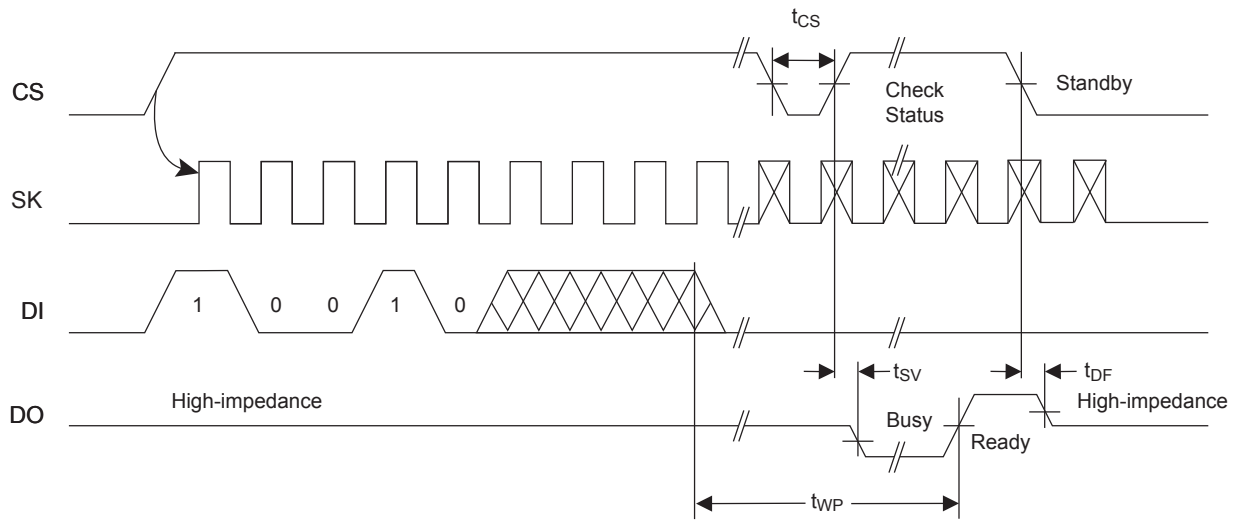
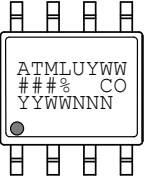

Figure 5-7. ERAL Timing



6. Packaging Information

6.1 Package Marking Information

AT93C86A: Package Marking Information

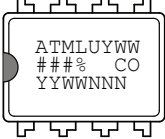
<p>8-lead SOIC</p> 	<p>8-lead TSSOP</p> 
<p>8-pad UDFN</p> <p>2.0 x 3.0 mm Body</p> 	<p>8-lead PDIP</p> 

Note 1: ● designates pin 1
Note 2: Package drawings are not to scale

Catalog Number Truncation		Truncation Code ###: 86A	
AT93C86A			
Date Codes			Voltages
YY = Year	Y = Year	WW = Work Week of Assembly	% = Minimum Voltage
16: 2016 20: 2020	6: 2016 0: 2020	02: Week 2	L: 1.8V min
17: 2017 21: 2021	7: 2017 1: 2021	04: Week 4	Blank: 2.7V min
18: 2018 22: 2022	8: 2018 2: 2022	...	
19: 2019 23: 2023	9: 2019 3: 2023	52: Week 52	
Country of Origin		Device Grade	Atmel Truncation
CO = Country of Origin		H or U: Industrial Grade	AT: Atmel ATM: Atmel ATML: Atmel
Lot Number or Trace Code			
NNN = Alphanumeric Trace Code			

8-Lead Plastic Small Outline (SN) - Narrow, 3.90 mm (.150 In.) Body [SOIC]

Note: For the most current package drawings, please see the Microchip Packaging Specification located at <http://www.microchip.com/packaging>

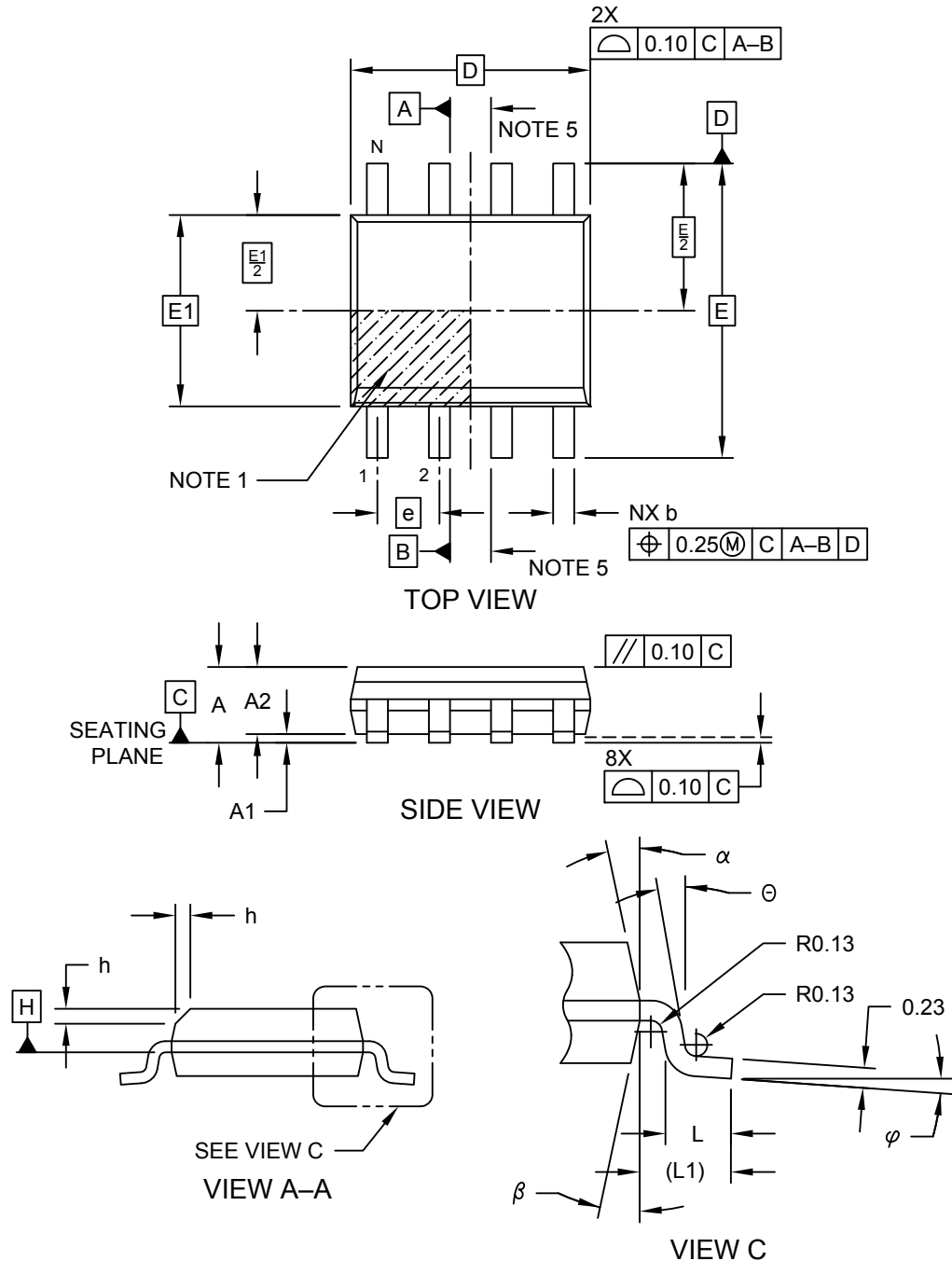

Microchip Technology Drawing No. C04-057-SN Rev E Sheet 1 of 2

8-Lead Plastic Small Outline (SN) - Narrow, 3.90 mm (.150 In.) Body [SOIC]

Note: For the most current package drawings, please see the Microchip Packaging Specification located at <http://www.microchip.com/packaging>

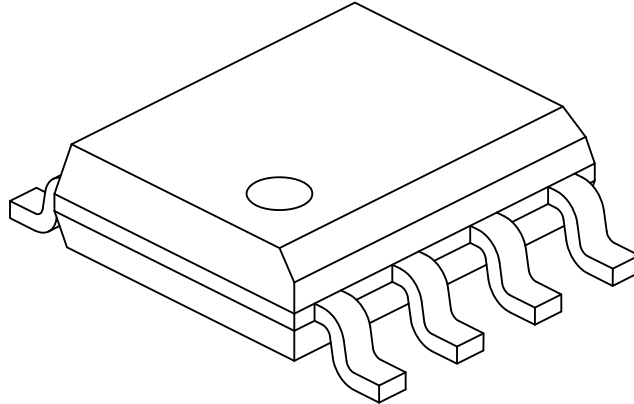

Dimension Limits	Units	MILLIMETERS		
		MIN	NOM	MAX
Number of Pins	N	8		
Pitch	e	1.27 BSC		
Overall Height	A	-	-	1.75
Molded Package Thickness	A2	1.25	-	-
Standoff §	A1	0.10	-	0.25
Overall Width	E	6.00 BSC		
Molded Package Width	E1	3.90 BSC		
Overall Length	D	4.90 BSC		
Chamfer (Optional)	h	0.25	-	0.50
Foot Length	L	0.40	-	1.27
Footprint	L1	1.04 REF		
Foot Angle	φ	0°	-	8°
Lead Thickness	c	0.17	-	0.25
Lead Width	b	0.31	-	0.51
Mold Draft Angle Top	α	5°	-	15°
Mold Draft Angle Bottom	β	5°	-	15°

Notes:

1. Pin 1 visual index feature may vary, but must be located within the hatched area.
2. § Significant Characteristic
3. Dimensions D and E1 do not include mold flash or protrusions. Mold flash or protrusions shall not exceed 0.15mm per side.
4. Dimensioning and tolerancing per ASME Y14.5M
 - BSC: Basic Dimension. Theoretically exact value shown without tolerances.
 - REF: Reference Dimension, usually without tolerance, for information purposes only.
5. Datums A & B to be determined at Datum H.

Microchip Technology Drawing No. C04-057-SN Rev E Sheet 2 of 2

8-Lead Plastic Small Outline (SN) - Narrow, 3.90 mm Body [SOIC]

Note: For the most current package drawings, please see the Microchip Packaging Specification located at <http://www.microchip.com/packaging>

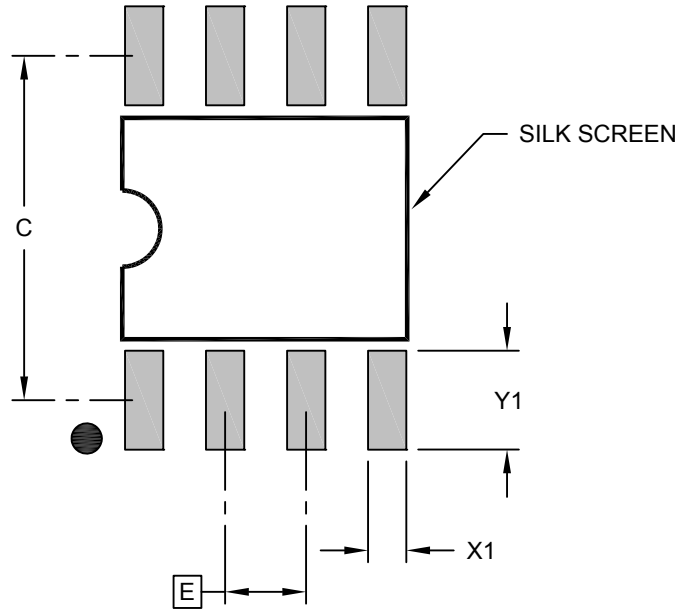

RECOMMENDED LAND PATTERN

		Units	MILLIMETERS		
		Dimension Limits	MIN	NOM	MAX
Contact Pitch	E		1.27 BSC		
Contact Pad Spacing	C		5.40		
Contact Pad Width (X8)	X1				0.60
Contact Pad Length (X8)	Y1				1.55

Notes:

1. Dimensioning and tolerancing per ASME Y14.5M
 BSC: Basic Dimension. Theoretically exact value shown without tolerances.

Microchip Technology Drawing C04-2057-SN Rev E

8-Lead Plastic Thin Shrink Small Outline (ST) – 4.4 mm Body [TSSOP]

Note: For the most current package drawings, please see the Microchip Packaging Specification located at <http://www.microchip.com/packaging>

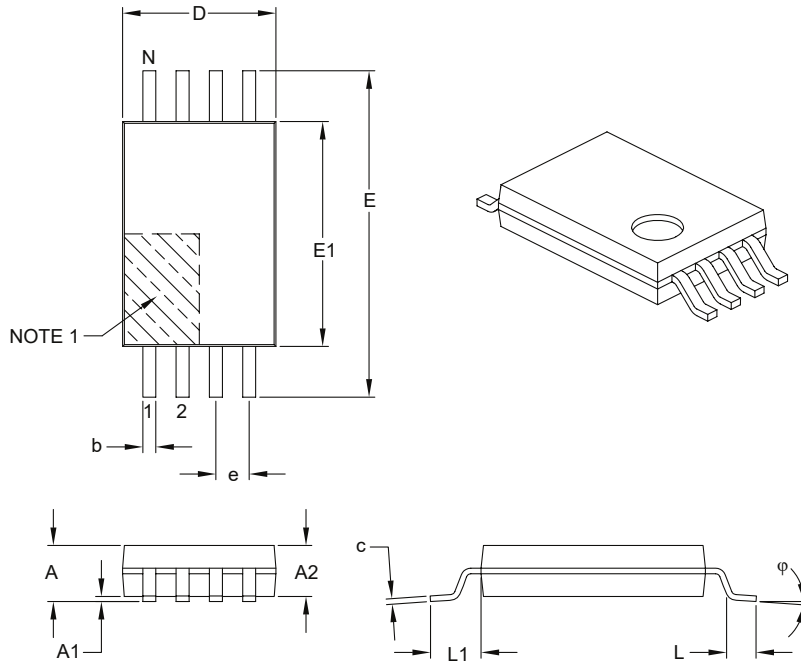

Dimension Limits	Units	MILLIMETERS		
		MIN	NOM	MAX
Number of Pins	N	8		
Pitch	e	0.65 BSC		
Overall Height	A	–	–	1.20
Molded Package Thickness	A2	0.80	1.00	1.05
Standoff	A1	0.05	–	0.15
Overall Width	E	6.40 BSC		
Molded Package Width	E1	4.30	4.40	4.50
Molded Package Length	D	2.90	3.00	3.10
Foot Length	L	0.45	0.60	0.75
Footprint	L1	1.00 REF		
Foot Angle	ϕ	0°	–	8°
Lead Thickness	c	0.09	–	0.20
Lead Width	b	0.19	–	0.30

Notes:

1. Pin 1 visual index feature may vary, but must be located within the hatched area.
2. Dimensions D and E1 do not include mold flash or protrusions. Mold flash or protrusions shall not exceed 0.15 mm per side.
3. Dimensioning and tolerancing per ASME Y14.5M.

BSC: Basic Dimension. Theoretically exact value shown without tolerances.

REF: Reference Dimension, usually without tolerance, for information purposes only.

Microchip Technology Drawing C04-086B

8-Lead Plastic Thin Shrink Small Outline (ST) - 4.4 mm Body [TSSOP]

Note: For the most current package drawings, please see the Microchip Packaging Specification located at <http://www.microchip.com/packaging>

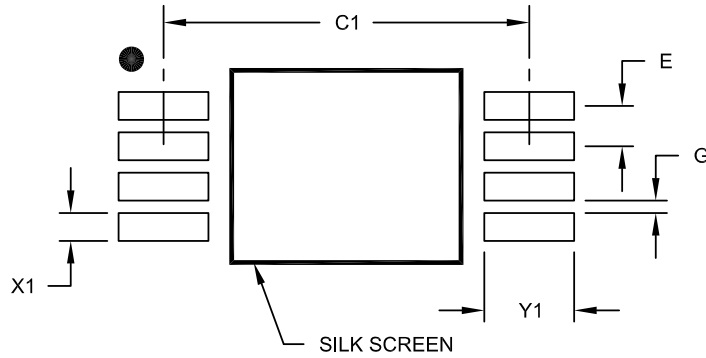

RECOMMENDED LAND PATTERN

Dimension Limits	Units	MILLIMETERS		
		MIN	NOM	MAX
Contact Pitch	E	0.65 BSC		
Contact Pad Spacing	C1		5.90	
Contact Pad Width (X8)	X1			0.45
Contact Pad Length (X8)	Y1			1.45
Distance Between Pads	G	0.20		

Notes:

1. Dimensioning and tolerancing per ASME Y14.5M

BSC: Basic Dimension. Theoretically exact value shown without tolerances.

Microchip Technology Drawing No. C04-2086A

**8-Lead Ultra Thin Plastic Dual Flat, No Lead Package (Q4B) - 2x3 mm Body [UDFN]
Atmel Legacy YNZ Package**

Note: For the most current package drawings, please see the Microchip Packaging Specification located at <http://www.microchip.com/packaging>

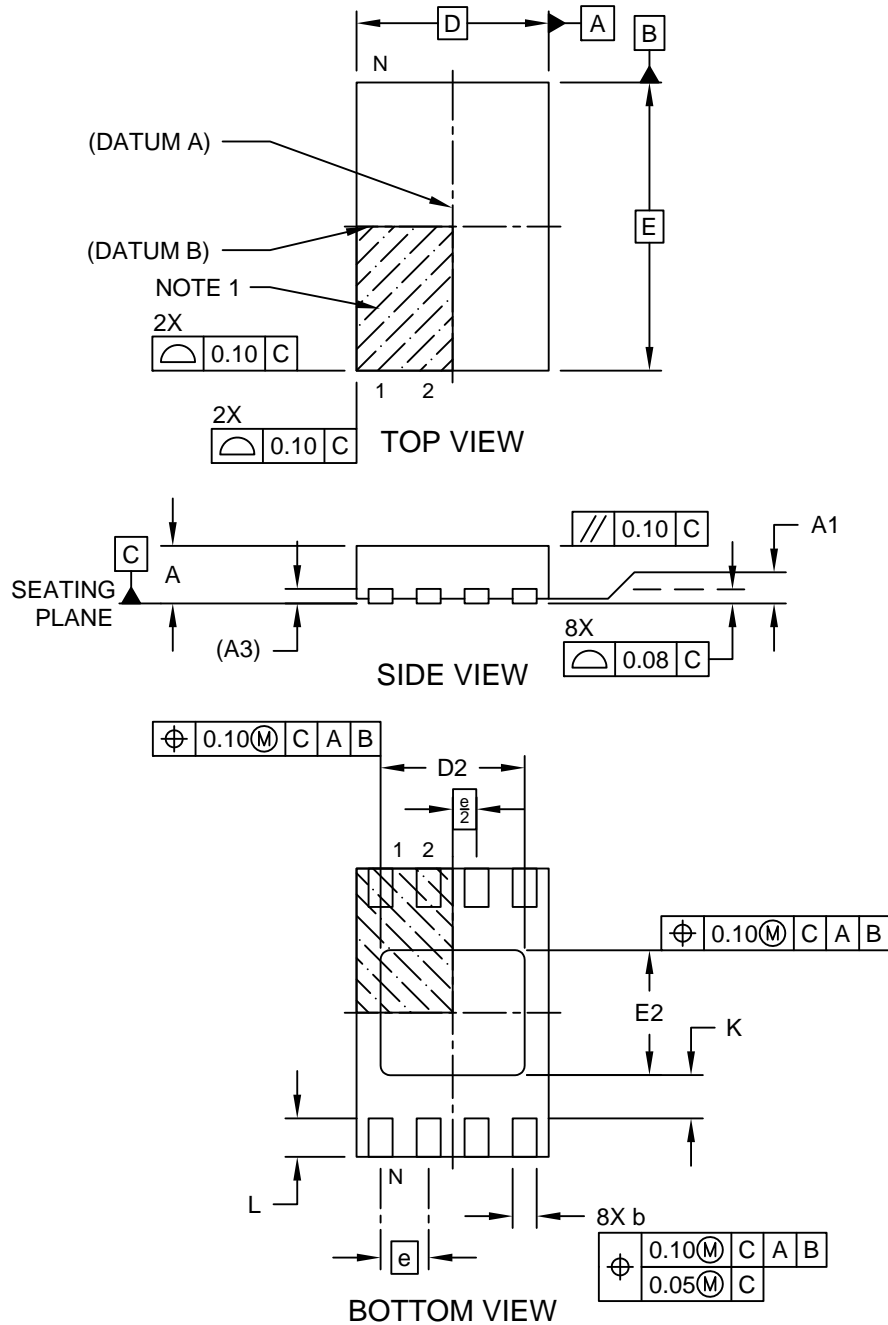

Microchip Technology Drawing C04-21355-Q4B Rev A Sheet 1 of 2

8-Lead Ultra Thin Plastic Dual Flat, No Lead Package (Q4B) - 2x3 mm Body [UDFN] Atmel Legacy YNZ Package

Note: For the most current package drawings, please see the Microchip Packaging Specification located at <http://www.microchip.com/packaging>

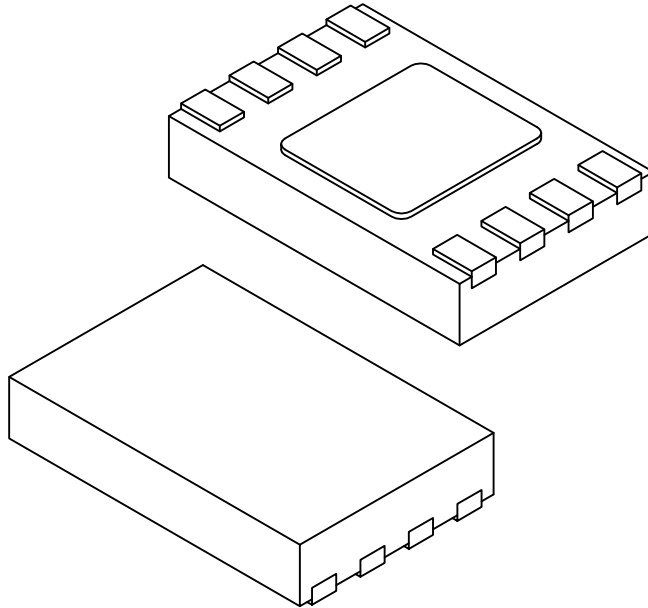

Dimension	Units	MILLIMETERS		
		MIN	NOM	MAX
Number of Terminals	N	8		
Pitch	e	0.50 BSC		
Overall Height	A	0.50	0.55	0.60
Standoff	A1	0.00	0.02	0.05
Terminal Thickness	A3	0.152 REF		
Overall Length	D	2.00 BSC		
Exposed Pad Length	D2	1.40	1.50	1.60
Overall Width	E	3.00 BSC		
Exposed Pad Width	E2	1.20	1.30	1.40
Terminal Width	b	0.18	0.25	0.30
Terminal Length	L	0.35	0.40	0.45
Terminal-to-Exposed-Pad	K	0.20	-	-

Notes:

1. Pin 1 visual index feature may vary, but must be located within the hatched area.
2. Package is saw singulated
3. Dimensioning and tolerancing per ASME Y14.5M

BSC: Basic Dimension. Theoretically exact value shown without tolerances.

REF: Reference Dimension, usually without tolerance, for information purposes only.

Microchip Technology Drawing C04-21355-Q4B Rev A Sheet 2 of 2

**8-Lead Ultra Thin Plastic Dual Flat, No Lead Package (Q4B) - 2x3 mm Body [UDFN]
Atmel Legacy YNZ Package**

Note: For the most current package drawings, please see the Microchip Packaging Specification located at <http://www.microchip.com/packaging>

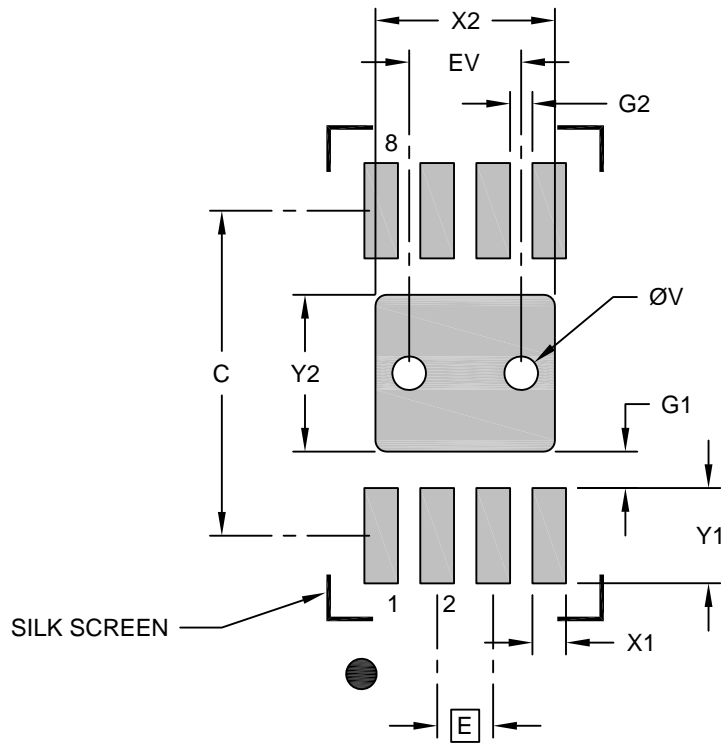

RECOMMENDED LAND PATTERN

Dimension	Units	MILLIMETERS		
		MIN	NOM	MAX
Contact Pitch	E	0.50 BSC		
Optional Center Pad Width	X2			1.60
Optional Center Pad Length	Y2			1.40
Contact Pad Spacing	C		2.90	
Contact Pad Width (X8)	X1			0.30
Contact Pad Length (X8)	Y1			0.85
Contact Pad to Center Pad (X8)	G1	0.20		
Contact Pad to Contact Pad (X6)	G2	0.33		
Thermal Via Diameter	V		0.30	
Thermal Via Pitch	EV		1.00	

Notes:

1. Dimensioning and tolerancing per ASME Y14.5M
BSC: Basic Dimension. Theoretically exact value shown without tolerances.
2. For best soldering results, thermal vias, if used, should be filled or tented to avoid solder loss during reflow process

Microchip Technology Drawing C04-21355-Q4B Rev A

AT93C86A

Packaging Information

8-Lead Plastic Dual In-Line (P) - 300 mil Body [PDIP]

Note: For the most current package drawings, please see the Microchip Packaging Specification located at <http://www.microchip.com/packaging>

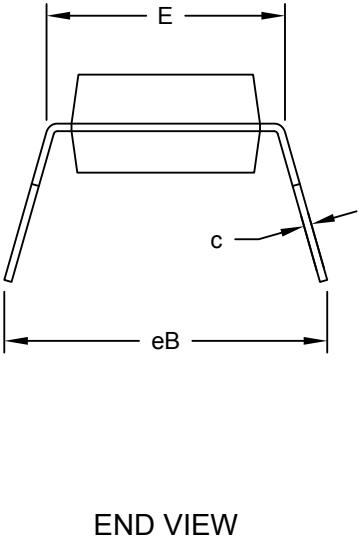
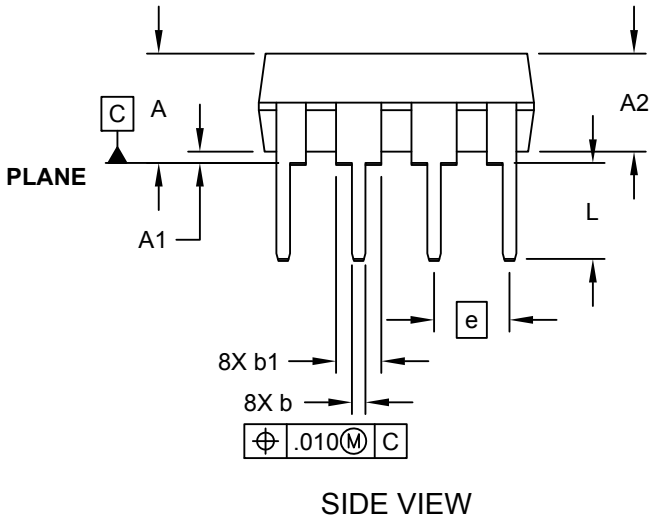
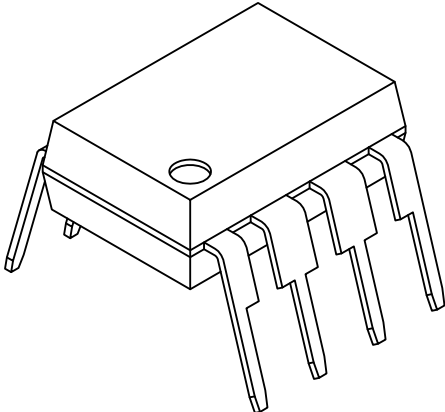
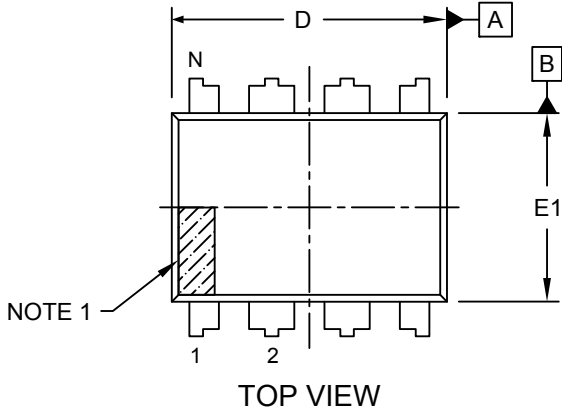

Microchip Technology Drawing No. C04-018-P Rev E Sheet 1 of 2

8-Lead Plastic Dual In-Line (P) - 300 mil Body [PDIP]

Note: For the most current package drawings, please see the Microchip Packaging Specification located at <http://www.microchip.com/packaging>

ALTERNATE LEAD DESIGN
(NOTE 5)

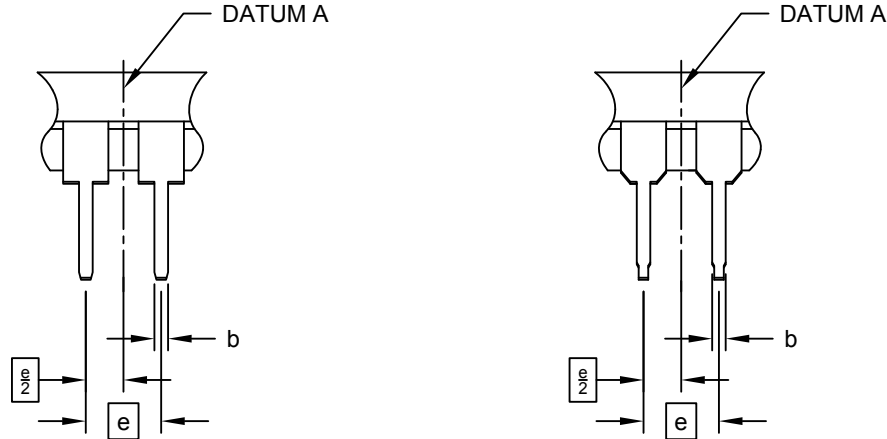

Dimension Limits	Units	INCHES		
		MIN	NOM	MAX
Number of Pins	N	8		
Pitch	e	.100 BSC		
Top to Seating Plane	A	-	-	.210
Molded Package Thickness	A2	.115	.130	.195
Base to Seating Plane	A1	.015	-	-
Shoulder to Shoulder Width	E	.290	.310	.325
Molded Package Width	E1	.240	.250	.280
Overall Length	D	.348	.365	.400
Tip to Seating Plane	L	.115	.130	.150
Lead Thickness	c	.008	.010	.015
Upper Lead Width	b1	.040	.060	.070
Lower Lead Width	b	.014	.018	.022
Overall Row Spacing	§ eB	-	-	.430

Notes:

1. Pin 1 visual index feature may vary, but must be located within the hatched area.
2. § Significant Characteristic
3. Dimensions D and E1 do not include mold flash or protrusions. Mold flash or protrusions shall not exceed .010" per side.
4. Dimensioning and tolerancing per ASME Y14.5M
BSC: Basic Dimension. Theoretically exact value shown without tolerances.
5. Lead design above seating plane may vary, based on assembly vendor.

Microchip Technology Drawing No. C04-018-P Rev E Sheet 2 of 2

7. Revision History

Revision A (October 2019)

Updated to the Microchip template. Microchip DS20006261 replaces Atmel documents 3408. Updated Package Marking Information. Removed lead finish designation. Updated trace code format in package markings. Updated section content throughout for clarification. Updated the PDIP, SOIC, TSSOP and UDFN package drawings to Microchip format.

Atmel AT93C86A 3408 Revision L (January 2017)

Added Bulk (Tube) Shipping Carrier Option. Changed Standard Quantity Tape and Reel Option to "T". Updated Ordering Information Table. Removed AT93C86A-W1.8-11 Part Number

Atmel AT93C86A 3408 Revision K (December 2015)

Correct Ordering Code Detail and update the 8S1 and 8MA2 package drawings

Atmel AT93C86A 3408 Revision J (January 2015)

Add the UDFN extended quantity option and update the ordering information section. Update the 8MA2 and 8P3 package drawings.

Atmel AT93C86A 3408 Revision I (August 2014)

Update pinouts, 8MA2 package drawings, grammatical changes, document template, logos, and disclaimer page. No changes to functional specification.

Atmel AT93C86A 3408 Revision H (January 2007)

Add "Bottom View" to page 1 Ultra Thin MiniMap package drawing page 4 revise Note 1 added "ensured by characterization".

Atmel AT93C86A 3408 Revision G (July 2006)

Revision history implemented. Delete 'Preliminary' status from data sheet; Add 'Ultra Thin' description to MLP 2x3 package; Delete '1.8V not available' on Figure 1 Note; Add 1.8V range on Table 4 under Write Cycle Time.

The Microchip Website

Microchip provides online support via our website at <http://www.microchip.com/>. This website is used to make files and information easily available to customers. Some of the content available includes:

- **Product Support** – Data sheets and errata, application notes and sample programs, design resources, user's guides and hardware support documents, latest software releases and archived software
- **General Technical Support** – Frequently Asked Questions (FAQs), technical support requests, online discussion groups, Microchip design partner program member listing
- **Business of Microchip** – Product selector and ordering guides, latest Microchip press releases, listing of seminars and events, listings of Microchip sales offices, distributors and factory representatives

Product Change Notification Service

Microchip's product change notification service helps keep customers current on Microchip products. Subscribers will receive email notification whenever there are changes, updates, revisions or errata related to a specified product family or development tool of interest.

To register, go to <http://www.microchip.com/pcn> and follow the registration instructions.

Customer Support

Users of Microchip products can receive assistance through several channels:

- Distributor or Representative
- Local Sales Office
- Embedded Solutions Engineer (ESE)
- Technical Support

Customers should contact their distributor, representative or ESE for support. Local sales offices are also available to help customers. A listing of sales offices and locations is included in this document.

Technical support is available through the website at: <http://www.microchip.com/support>

Product Identification System

To order or obtain information, e.g., on pricing or delivery, refer to the factory or the listed sales office.

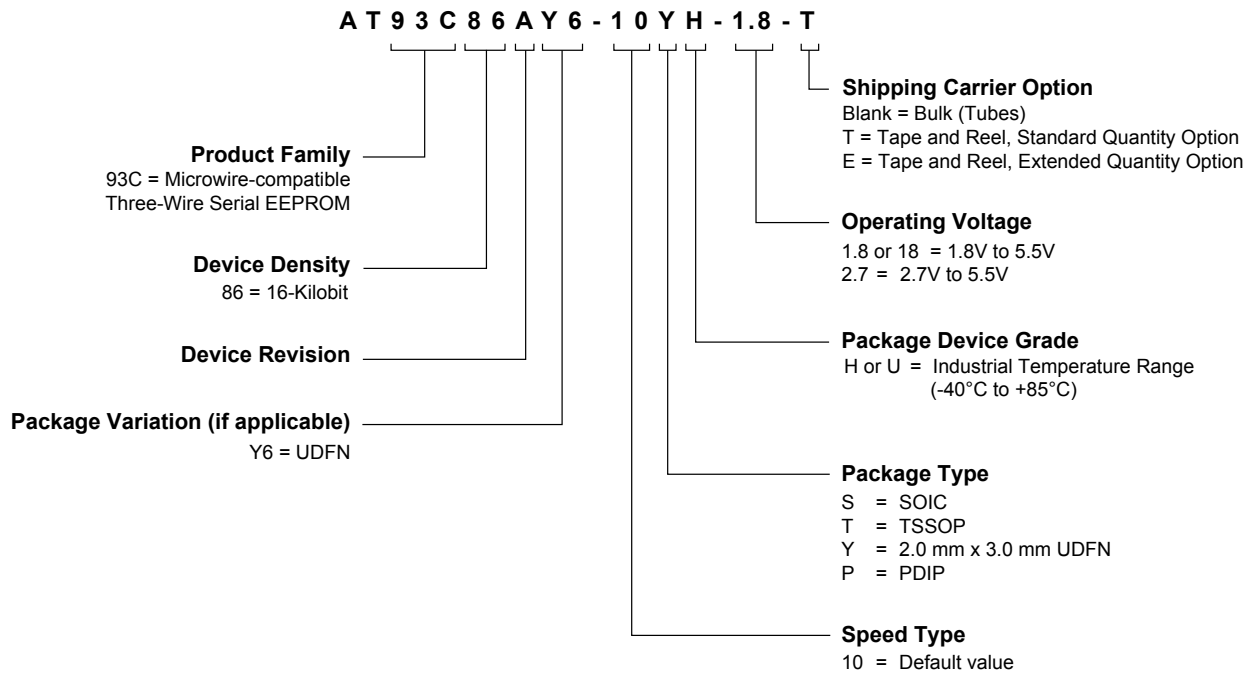

Note: Refer to automotive data sheet for automotive grade ordering information.

Examples

Device	Package	Package Drawing Code	Package Option	Voltage Range	Shipping Carrier Option	Device Grade
AT93C86A-10SU-1.8	SOIC	SN	S	1.8V to 5.5V	Bulk (Tubes)	Industrial Temperature (-40°C to 85°C)
AT93C86A-10SU-2.7-T	SOIC	SN	S	2.7V to 5.5V	Tape and Reel	
AT93C86A-10TU-1.8	TSSOP	ST	T	1.8V to 5.5V	Bulk (Tubes)	
AT93C86A-10TU-2.7-T	TSSOP	ST	T	2.7V to 5.5V	Tape and Reel	
AT93C86AY6-10YH-1.8-T	UDFN	Q4B	Y	1.8V to 5.5V	Tape and Reel	
AT93C86AY6-10YH-18-E	UDFN	Q4B	Y	1.8V to 5.5V	Extended Qty., Tape and Reel	
AT93C86A-10PU-2.7	PDIP	P	P	2.7V to 5.5V	Bulk (Tubes)	

Microchip Devices Code Protection Feature

Note the following details of the code protection feature on Microchip devices:

- Microchip products meet the specification contained in their particular Microchip Data Sheet.
- Microchip believes that its family of products is one of the most secure families of its kind on the market today, when used in the intended manner and under normal conditions.
- There are dishonest and possibly illegal methods used to breach the code protection feature. All of these methods, to our knowledge, require using the Microchip products in a manner outside the operating specifications contained in Microchip's Data Sheets. Most likely, the person doing so is engaged in theft of intellectual property.

- Microchip is willing to work with the customer who is concerned about the integrity of their code.
- Neither Microchip nor any other semiconductor manufacturer can guarantee the security of their code. Code protection does not mean that we are guaranteeing the product as “unbreakable.”

Code protection is constantly evolving. We at Microchip are committed to continuously improving the code protection features of our products. Attempts to break Microchip’s code protection feature may be a violation of the Digital Millennium Copyright Act. If such acts allow unauthorized access to your software or other copyrighted work, you may have a right to sue for relief under that Act.

Legal Notice

Information contained in this publication regarding device applications and the like is provided only for your convenience and may be superseded by updates. It is your responsibility to ensure that your application meets with your specifications. MICROCHIP MAKES NO REPRESENTATIONS OR WARRANTIES OF ANY KIND WHETHER EXPRESS OR IMPLIED, WRITTEN OR ORAL, STATUTORY OR OTHERWISE, RELATED TO THE INFORMATION, INCLUDING BUT NOT LIMITED TO ITS CONDITION, QUALITY, PERFORMANCE, MERCHANTABILITY OR FITNESS FOR PURPOSE. Microchip disclaims all liability arising from this information and its use. Use of Microchip devices in life support and/or safety applications is entirely at the buyer’s risk, and the buyer agrees to defend, indemnify and hold harmless Microchip from any and all damages, claims, suits, or expenses resulting from such use. No licenses are conveyed, implicitly or otherwise, under any Microchip intellectual property rights unless otherwise stated.

Trademarks

The Microchip name and logo, the Microchip logo, Adaptec, AnyRate, AVR, AVR logo, AVR Freaks, BesTime, BitCloud, chipKIT, chipKIT logo, CryptoMemory, CryptoRF, dsPIC, FlashFlex, flexPWR, HELDO, IGLOO, JukeBlox, KeeLoq, Klear, LANCheck, LinkMD, maXStylus, maXTouch, MediaLB, megaAVR, Microsemi, Microsemi logo, MOST, MOST logo, MPLAB, OptoLyzer, PackeTime, PIC, picoPower, PICSTART, PIC32 logo, PolarFire, Prochip Designer, QTouch, SAM-BA, SenGenuity, SpyNIC, SST, SST Logo, SuperFlash, Symmetricom, SyncServer, Tachyon, TempTrackr, TimeSource, tinyAVR, UNI/O, Vectron, and XMEGA are registered trademarks of Microchip Technology Incorporated in the U.S.A. and other countries.

APT, ClockWorks, The Embedded Control Solutions Company, EtherSynch, FlashTec, Hyper Speed Control, HyperLight Load, IntelliMOS, Libero, motorBench, mTouch, Powermite 3, Precision Edge, ProASIC, ProASIC Plus, ProASIC Plus logo, Quiet-Wire, SmartFusion, SyncWorld, Temux, TimeCesium, TimeHub, TimePictra, TimeProvider, Vite, WinPath, and ZL are registered trademarks of Microchip Technology Incorporated in the U.S.A.

Adjacent Key Suppression, AKS, Analog-for-the-Digital Age, Any Capacitor, AnyIn, AnyOut, BlueSky, BodyCom, CodeGuard, CryptoAuthentication, CryptoAutomotive, CryptoCompanion, CryptoController, dsPICDEM, dsPICDEM.net, Dynamic Average Matching, DAM, ECAN, EtherGREEN, In-Circuit Serial Programming, ICSP, INICnet, Inter-Chip Connectivity, JitterBlocker, KlearNet, KlearNet logo, memBrain, Mindi, MiWi, MPASM, MPF, MPLAB Certified logo, MPLIB, MPLINK, MultiTRAK, NetDetach, Omniscient Code Generation, PICDEM, PICDEM.net, PICkit, PICtail, PowerSmart, PureSilicon, QMatrix, REAL ICE, Ripple Blocker, SAM-ICE, Serial Quad I/O, SMART-I.S., SQI, SuperSwitcher, SuperSwitcher II, Total Endurance, TSHARC, USBCheck, VariSense, ViewSpan, WiperLock, Wireless DNA, and ZENA are trademarks of Microchip Technology Incorporated in the U.S.A. and other countries.

SQTP is a service mark of Microchip Technology Incorporated in the U.S.A.

The Adaptec logo, Frequency on Demand, Silicon Storage Technology, and Symmcom are registered trademarks of Microchip Technology Inc. in other countries.

GestIC is a registered trademark of Microchip Technology Germany II GmbH & Co. KG, a subsidiary of Microchip Technology Inc., in other countries.

All other trademarks mentioned herein are property of their respective companies.

© 2019, Microchip Technology Incorporated, Printed in the U.S.A., All Rights Reserved.

ISBN: 978-1-5224-5156-3

AMBA, Arm, Arm7, Arm7TDMI, Arm9, Arm11, Artisan, big.LITTLE, Cordio, CoreLink, CoreSight, Cortex, DesignStart, DynamIQ, Jazelle, Keil, Mali, Mbed, Mbed Enabled, NEON, POP, RealView, SecurCore, Socrates, Thumb, TrustZone, ULINK, ULINK2, ULINK-ME, ULINK-PLUS, ULINKpro, μ Vision, Versatile are trademarks or registered trademarks of Arm Limited (or its subsidiaries) in the US and/or elsewhere.

Quality Management System

For information regarding Microchip's Quality Management Systems, please visit <http://www.microchip.com/quality>.

Worldwide Sales and Service

AMERICAS	ASIA/PACIFIC	ASIA/PACIFIC	EUROPE
Corporate Office 2355 West Chandler Blvd. Chandler, AZ 85224-6199 Tel: 480-792-7200 Fax: 480-792-7277 Technical Support: http://www.microchip.com/support Web Address: http://www.microchip.com	Australia - Sydney Tel: 61-2-9868-6733 China - Beijing Tel: 86-10-8569-7000 China - Chengdu Tel: 86-28-8665-5511 China - Chongqing Tel: 86-23-8980-9588 China - Dongguan Tel: 86-769-8702-9880 China - Guangzhou Tel: 86-20-8755-8029 China - Hangzhou Tel: 86-571-8792-8115 China - Hong Kong SAR Tel: 852-2943-5100 China - Nanjing Tel: 86-25-8473-2460 China - Qingdao Tel: 86-532-8502-7355 China - Shanghai Tel: 86-21-3326-8000 China - Shenyang Tel: 86-24-2334-2829 China - Shenzhen Tel: 86-755-8864-2200 China - Suzhou Tel: 86-186-6233-1526 China - Wuhan Tel: 86-27-5980-5300 China - Xian Tel: 86-29-8833-7252 China - Xiamen Tel: 86-592-2388138 China - Zhuhai Tel: 86-756-3210040	India - Bangalore Tel: 91-80-3090-4444 India - New Delhi Tel: 91-11-4160-8631 India - Pune Tel: 91-20-4121-0141 Japan - Osaka Tel: 81-6-6152-7160 Japan - Tokyo Tel: 81-3-6880-3770 Korea - Daegu Tel: 82-53-744-4301 Korea - Seoul Tel: 82-2-554-7200 Malaysia - Kuala Lumpur Tel: 60-3-7651-7906 Malaysia - Penang Tel: 60-4-227-8870 Philippines - Manila Tel: 63-2-634-9065 Singapore Tel: 65-6334-8870 Taiwan - Hsin Chu Tel: 886-3-577-8366 Taiwan - Kaohsiung Tel: 886-7-213-7830 Taiwan - Taipei Tel: 886-2-2508-8600 Thailand - Bangkok Tel: 66-2-694-1351 Vietnam - Ho Chi Minh Tel: 84-28-5448-2100	Austria - Wels Tel: 43-7242-2244-39 Fax: 43-7242-2244-393 Denmark - Copenhagen Tel: 45-4450-2828 Fax: 45-4485-2829 Finland - Espoo Tel: 358-9-4520-820 France - Paris Tel: 33-1-69-53-63-20 Fax: 33-1-69-30-90-79 Germany - Garching Tel: 49-8931-9700 Germany - Haan Tel: 49-2129-3766400 Germany - Heilbronn Tel: 49-7131-72400 Germany - Karlsruhe Tel: 49-721-625370 Germany - Munich Tel: 49-89-627-144-0 Fax: 49-89-627-144-44 Germany - Rosenheim Tel: 49-8031-354-560 Israel - Ra'anana Tel: 972-9-744-7705 Italy - Milan Tel: 39-0331-742611 Fax: 39-0331-466781 Italy - Padova Tel: 39-049-7625286 Netherlands - Drunen Tel: 31-416-690399 Fax: 31-416-690340 Norway - Trondheim Tel: 47-72884388 Poland - Warsaw Tel: 48-22-3325737 Romania - Bucharest Tel: 40-21-407-87-50 Spain - Madrid Tel: 34-91-708-08-90 Fax: 34-91-708-08-91 Sweden - Gothenberg Tel: 46-31-704-60-40 Sweden - Stockholm Tel: 46-8-5090-4654 UK - Wokingham Tel: 44-118-921-5800 Fax: 44-118-921-5820
Atlanta Duluth, GA Tel: 678-957-9614 Fax: 678-957-1455 Austin, TX Tel: 512-257-3370 Boston Westborough, MA Tel: 774-760-0087 Fax: 774-760-0088 Chicago Itasca, IL Tel: 630-285-0071 Fax: 630-285-0075 Dallas Addison, TX Tel: 972-818-7423 Fax: 972-818-2924 Detroit Novi, MI Tel: 248-848-4000 Houston, TX Tel: 281-894-5983 Indianapolis Noblesville, IN Tel: 317-773-8323 Fax: 317-773-5453 Tel: 317-536-2380 Los Angeles Mission Viejo, CA Tel: 949-462-9523 Fax: 949-462-9608 Tel: 951-273-7800 Raleigh, NC Tel: 919-844-7510 New York, NY Tel: 631-435-6000 San Jose, CA Tel: 408-735-9110 Tel: 408-436-4270 Canada - Toronto Tel: 905-695-1980 Fax: 905-695-2078			