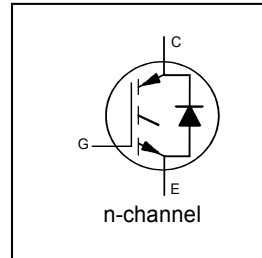


**INSULATED GATE BIPOLAR TRANSISTOR WITH ULTRAFAST SOFT RECOVERY DIODE**
**Features**

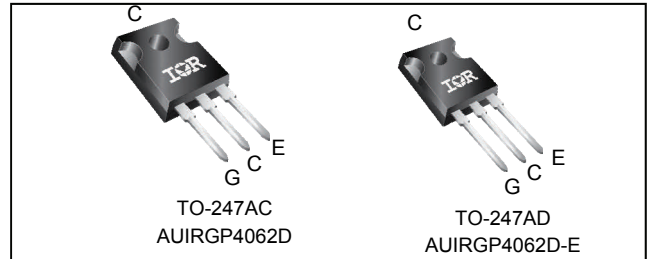
- Low  $V_{CE(on)}$  Trench IGBT Technology
- Low Switching Losses
- 5 $\mu$ s SCSOA
- Square RBSOA
- 100% of The Parts Tested for ILM<sup>①</sup>
- Positive  $V_{CE(on)}$  Temperature Coefficient.
- Ultra Fast Soft Recovery Co-pak Diode
- Tighter Distribution of Parameters
- Lead-Free, RoHS Compliant
- Automotive Qualified \*

**Benefits**

- High Efficiency in a Wide Range of Applications
- Suitable for a Wide Range of Switching Frequencies due to Low  $V_{CE(ON)}$  and Low Switching Losses
- Rugged Transient Performance for Increased Reliability
- Excellent Current Sharing in Parallel Operation
- Low EMI



$V_{CES} = 600V$   
 $I_C = 24A, T_C = 100^\circ C$   
 $t_{SC} \geq 5\mu s, T_{J(max)} = 175^\circ C$   
 $V_{CE(on)} \text{ typ.} = 1.60V$



G	C	E
Gate	Collector	Emitter

Base Part Number	Package Type	Standard Pack		Orderable Part Number
		Form	Quantity	
AUIRGP4062D	TO-247AC	Tube	25	AUIRGP4062D
AUIRGP4062D-E	TO-247AD	Tube	25	AUIRGP4062D-E

**Absolute Maximum Ratings**

Stresses beyond those listed under "Absolute Maximum Ratings" may cause permanent damage to the device. These are stress ratings only; and functional operation of the device at these or any other condition beyond those indicated in the specifications is not implied. Exposure to absolute-maximum-rated conditions for extended periods may affect device reliability. The thermal resistance and power dissipation ratings are measured under board mounted and still air conditions. Ambient temperature ( $T_A$ ) is 25°C, unless otherwise specified.

	Parameter	Max.	Units
$V_{CES}$	Collector-to-Emitter Voltage	600	V
$I_C @ T_C = 25^\circ C$	Continuous Collector Current	48	A
$I_C @ T_C = 100^\circ C$	Continuous Collector Current	24	
$I_{CM}$	Pulse Collector Current $V_{GE} = 15V$	72	
$I_{LM}$	Clamped Inductive Load Current $V_{GE} = 20V$ <sup>①</sup>	96	
$I_F @ T_C = 25^\circ C$	Diode Continuous Forward Current	48	
$I_F @ T_C = 100^\circ C$	Diode Continuous Forward Current	24	
$I_{FSM}$	Maximum Repetitive Forward Current <sup>③</sup>	96	V
$V_{GE}$	Continuous Gate-to-Emitter Voltage	$\pm 20$	
	Transient Gate-to-Emitter Voltage	$\pm 30$	
$P_D @ T_C = 25^\circ C$	Maximum Power Dissipation	250	W
$P_D @ T_C = 100^\circ C$	Maximum Power Dissipation	125	
$T_J$ $T_{STG}$	Operating Junction and Storage Temperature Range	-55 to +175	°C
	Soldering Temperature, for 10 sec.	300 (0.063 in.(1.6mm) from case)	
	Mounting Torque, 6-32 or M3 Screw	10 lbf·in (1.1 N·m)	

**Thermal Resistance**

	Parameter	Min.	Typ.	Max.	Units
$R_{\theta JC}$ (IGBT)	Thermal Resistance Junction-to-Case (each IGBT) TO-247	—	—	0.65	°C/W
$R_{\theta JC}$ (Diode)	Thermal Resistance Junction-to-Case (each Diode) TO-247	—	—	1.62	
$R_{\theta CS}$	Thermal Resistance, Case-to-Sink (flat, greased surface) TO-247	—	0.24	—	
$R_{\theta JA}$	Thermal Resistance, Junction-to-Ambient (typical socket mount) TO-247	—	40	—	

\* Qualification standards can be found at [www.infineon.com](http://www.infineon.com)

**Electrical Characteristics @ T<sub>J</sub> = 25°C (unless otherwise specified)**

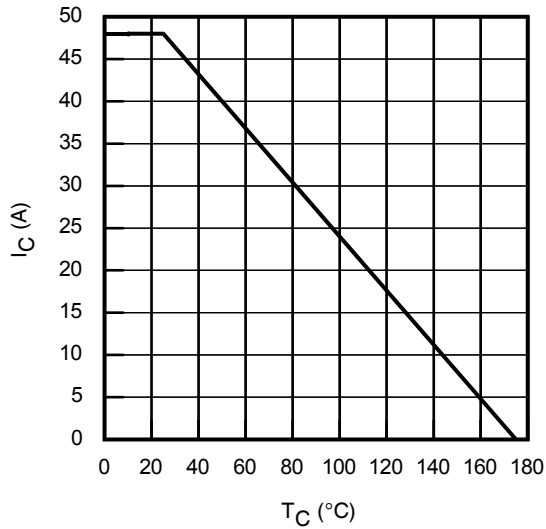
	Parameter	Min.	Typ.	Max.	Units	Conditions	Ref.
V <sub>(BR)CES</sub>	Collector-to-Emitter Breakdown Voltage	600	—	—	V	V <sub>GE</sub> = 0V, I <sub>C</sub> = 100μA <sup>④</sup>	CT6
ΔV <sub>(BR)CES</sub> /ΔT <sub>J</sub>	Temperature Coeff. of Breakdown Voltage	—	0.30	—	V/°C	V <sub>GE</sub> = 0V, I <sub>C</sub> = 1mA (25°C-175°C)	
V <sub>CE(on)</sub>	Collector-to-Emitter Saturation Voltage	—	1.60	1.95	V	I <sub>C</sub> = 24A, V <sub>GE</sub> = 15V, T <sub>J</sub> = 25°C	5,6,7
		—	2.03	—		I <sub>C</sub> = 24A, V <sub>GE</sub> = 15V, T <sub>J</sub> = 150°C	9,10,11
		—	2.04	—		I <sub>C</sub> = 24A, V <sub>GE</sub> = 15V, T <sub>J</sub> = 175°C	
V <sub>GE(th)</sub>	Gate Threshold Voltage	4.0	—	6.5	V	I <sub>C</sub> = 700μA	9,10,
ΔV <sub>GE(th)</sub> /ΔT <sub>J</sub>	Threshold Voltage temp. coefficient	—	-18	—	mV/°C	V <sub>CE</sub> = V <sub>GE</sub> , I <sub>C</sub> = 1.0mA (25°C-175°C)	11,12
g <sub>fe</sub>	Forward Transconductance	—	17	—	S	V <sub>CE</sub> = 50V, I <sub>C</sub> = 24A, PW = 80μs	
I <sub>CES</sub>	Collector-to-Emitter Leakage Current	—	2.0	25	μA	V <sub>GE</sub> = 0V, V <sub>CE</sub> = 600V	
		—	775	—		V <sub>GE</sub> = 0V, V <sub>CE</sub> = 600V, T <sub>J</sub> = 175°C	
V <sub>FM</sub>	Diode Forward Voltage Drop	—	1.80	2.6	V	I <sub>F</sub> = 24A	8
		—	1.28	—		I <sub>F</sub> = 24A, T <sub>J</sub> = 175°C	
I <sub>GES</sub>	Gate-to-Emitter Leakage Current	—	—	±100	nA	V <sub>GE</sub> = ±20V, V <sub>CE</sub> = 0V	

**Switching Characteristics @ T<sub>J</sub> = 25°C (unless otherwise specified)**

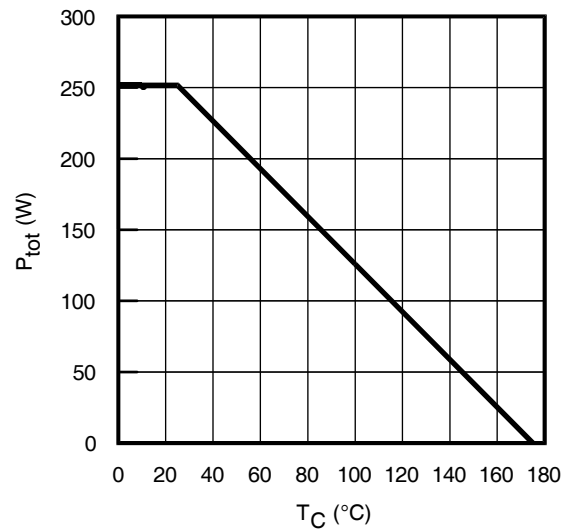
	Parameter	Min.	Typ.	Max.	Units	Conditions	Ref. Fig.
Q <sub>g</sub>	Total Gate Charge (turn-on)	—	50	75	nC	I <sub>C</sub> = 24A V <sub>GE</sub> = 15V V <sub>CC</sub> = 400V	24
Q <sub>ge</sub>	Gate-to-Emitter Charge (turn-on)	—	13	20			CT1
Q <sub>gc</sub>	Gate-to-Collector Charge (turn-on)	—	21	31			
E <sub>on</sub>	Turn-On Switching Loss	—	115	201	μJ	I <sub>C</sub> = 24A, V <sub>CC</sub> = 400V, V <sub>GE</sub> = +15V, T <sub>J</sub> = 25°C	CT4
E <sub>off</sub>	Turn-Off Switching Loss	—	600	700			
E <sub>total</sub>	Total Switching Loss	—	715	901			
t <sub>d(on)</sub>	Turn-On delay time	—	41	53	ns	R <sub>G</sub> = 10Ω, L = 200μH, L <sub>S</sub> = 150nH, Energy losses include tail & diode reverse recovery	CT4
t <sub>r</sub>	Rise time	—	22	31			
t <sub>d(off)</sub>	Turn-Off delay time	—	104	115			
t <sub>f</sub>	Fall time	—	29	41			
E <sub>on</sub>	Turn-On Switching Loss	—	420	—	μJ	I <sub>C</sub> = 24A, V <sub>CC</sub> = 400V, V <sub>GE</sub> = +15V, T <sub>J</sub> = 175°C <sup>④</sup>	13,15, CT4 WF1,WF2
E <sub>off</sub>	Turn-Off Switching Loss	—	840	—			
E <sub>total</sub>	Total Switching Loss	—	1260	—			
t <sub>d(on)</sub>	Turn-On delay time	—	40	—	ns	R <sub>G</sub> = 10Ω, L = 200μH, L <sub>S</sub> = 150nH Energy losses include tail & diode reverse recovery	14,16 CT4 WF1 WF2
t <sub>r</sub>	Rise time	—	24	—			
t <sub>d(off)</sub>	Turn-Off delay time	—	125	—			
t <sub>f</sub>	Fall time	—	39	—			
C <sub>ies</sub>	Input Capacitance	—	1490	—	pF	V <sub>GE</sub> = 0V V <sub>CC</sub> = 30V f = 1.0Mhz	23
C <sub>oes</sub>	Output Capacitance	—	129	—			
C <sub>res</sub>	Reverse Transfer Capacitance	—	45	—			
RBSOA	Reverse Bias Safe Operating Area	FULL SQUARE				T <sub>J</sub> = 175°C, I <sub>C</sub> = 96A V <sub>CC</sub> = 480V, V <sub>p</sub> = 600V R <sub>g</sub> = 10Ω, V <sub>GE</sub> = +20V to 0V	4 CT2
SCSOA	Short Circuit Safe Operating Area	5	—	—	μs	V <sub>CC</sub> = 400V, V <sub>p</sub> = 600V R <sub>g</sub> = 10Ω, V <sub>GE</sub> = +15V to 0V	22,CT3 WF4
E <sub>rec</sub>	Reverse Recovery Energy of the Diode	—	624	—	μJ	T <sub>J</sub> = 175°C	17,18,19, 20,21 WF3
t <sub>rr</sub>	Diode Reverse Recovery Time	—	89	—	ns	V <sub>CC</sub> = 400V, I <sub>F</sub> = 24A, V <sub>GE</sub> = 15V,	
I <sub>rr</sub>	Peak Reverse Recovery Current	—	37	—	A	R <sub>G</sub> = 10Ω, L = 200μH, L <sub>S</sub> = 150nH	

**Notes:**

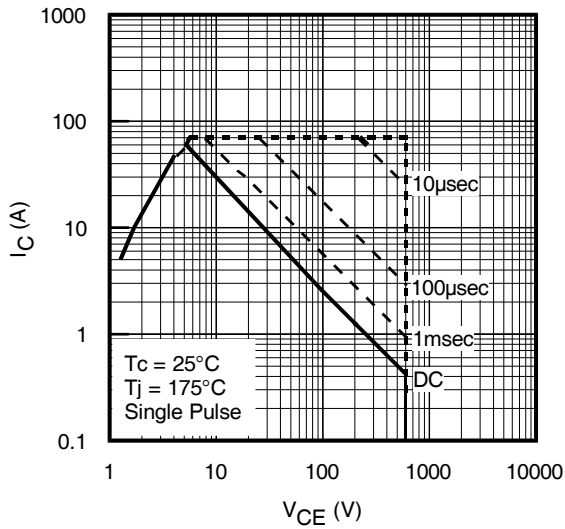
- ① V<sub>CC</sub> = 80% (V<sub>CES</sub>), V<sub>GE</sub> = 20V, L = 100μH, R<sub>G</sub> = 10Ω.
- ② This is only applied to TO-220AB package.
- ③ Pulse width limited by max. junction temperature.
- ④ Refer to AN-1086 for guidelines for measuring V<sub>(BR)CES</sub> safely.



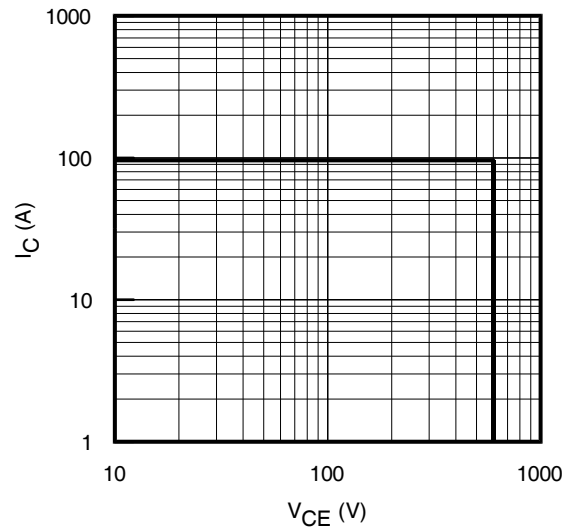
**Fig. 1** - Maximum DC Collector Current vs. Case Temperature



**Fig. 2** - Power Dissipation vs. Case Temperature

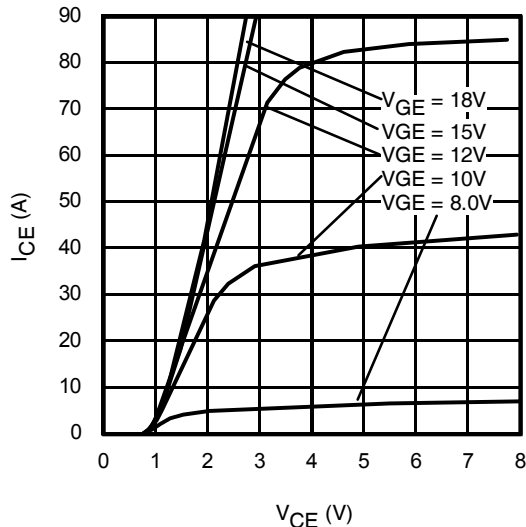


**Fig. 3** - Forward SOA

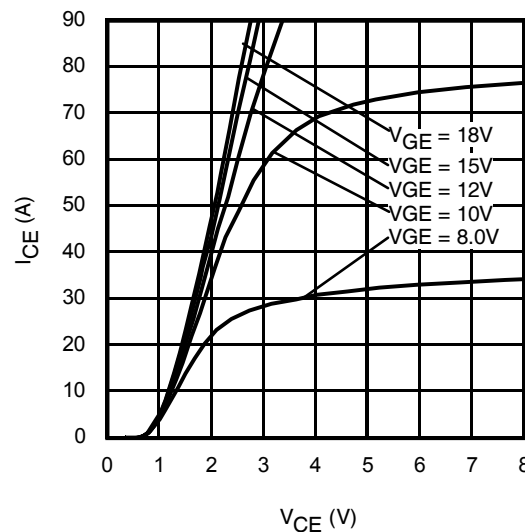


**Fig. 4** - Reverse Bias SOA  
T<sub>J</sub> = 175°C; V<sub>GE</sub> = 20V

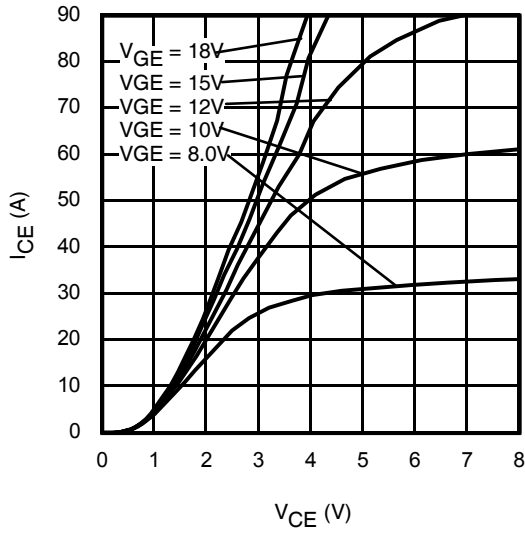
T<sub>C</sub> = 25°C, T<sub>J</sub> ≤ 175°C; V<sub>GE</sub> = 15V



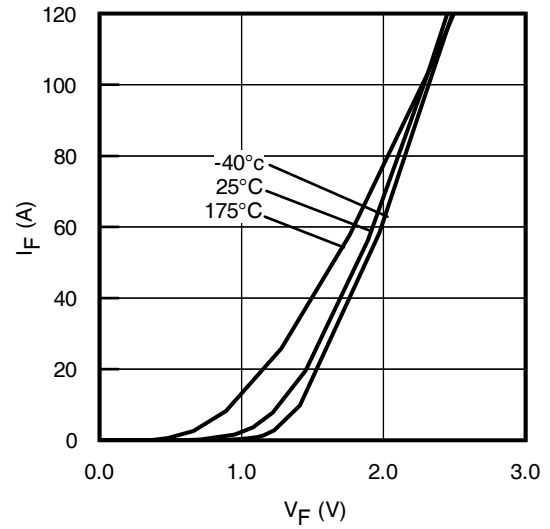
**Fig. 5** - Typ. IGBT Output Characteristics  
T<sub>J</sub> = -40°C; t<sub>p</sub> = 80µs



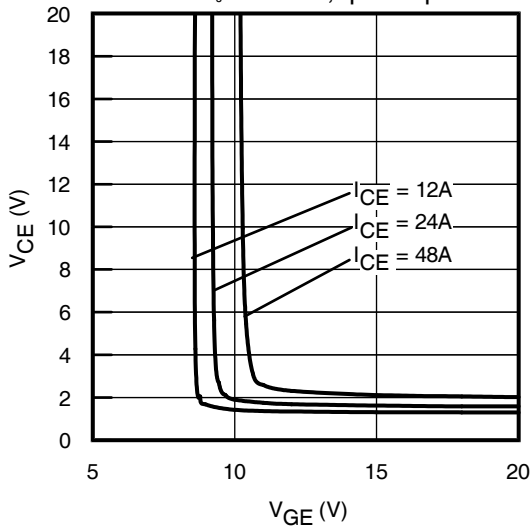
**Fig. 6** - Typ. IGBT Output Characteristics  
T<sub>J</sub> = 25°C; t<sub>p</sub> = 80µs



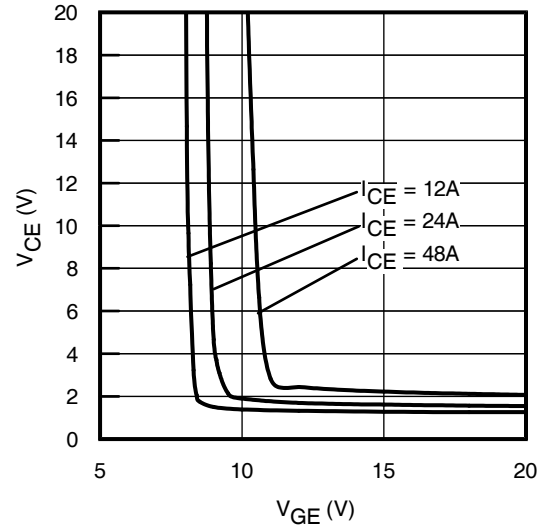
**Fig. 7 - Typ. IGBT Output Characteristics**  
 $T_J = 175^\circ\text{C}$ ;  $t_p = 80\mu\text{s}$



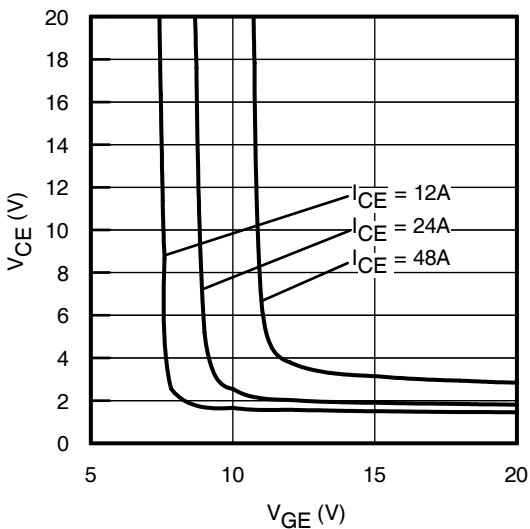
**Fig. 8 - Typ. Diode Forward Characteristics**  
 $t_p = 80\mu\text{s}$



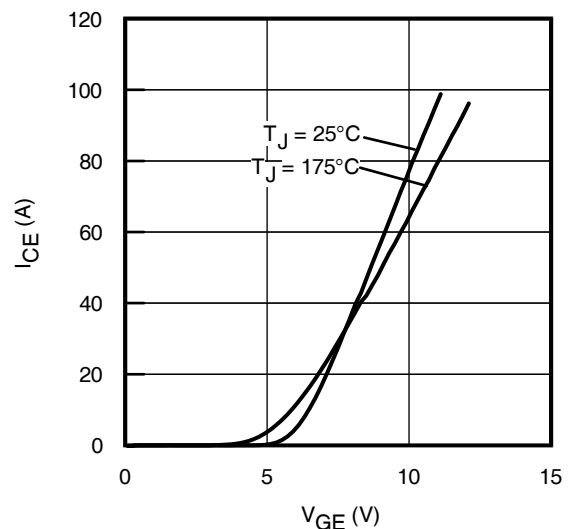
**Fig. 9 - Typical  $V_{CE}$  vs.  $V_{GE}$**   
 $T_J = -40^\circ\text{C}$



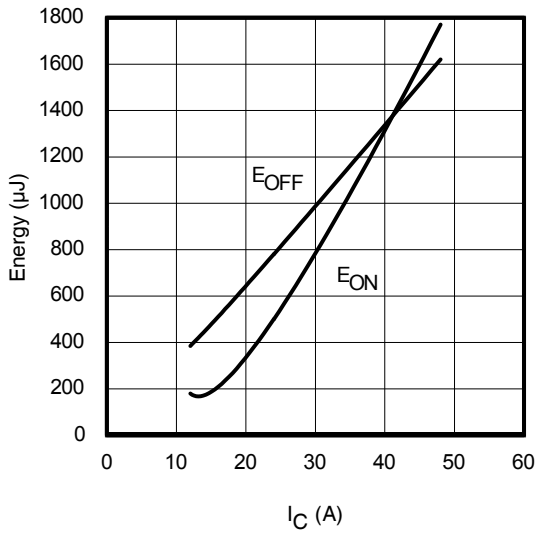
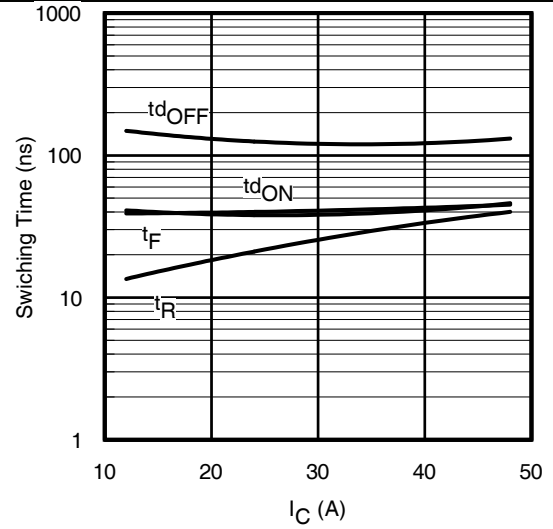
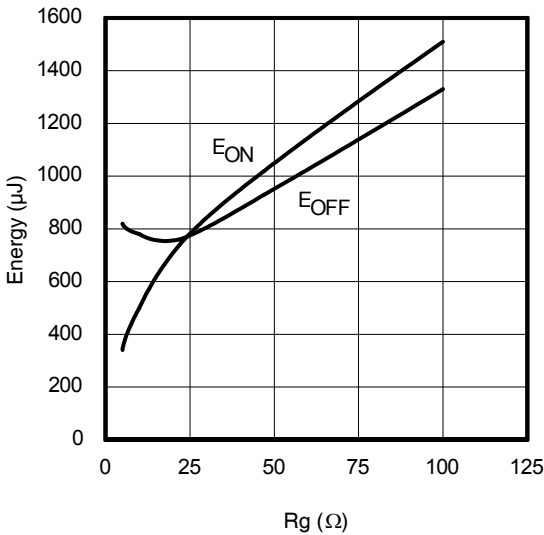
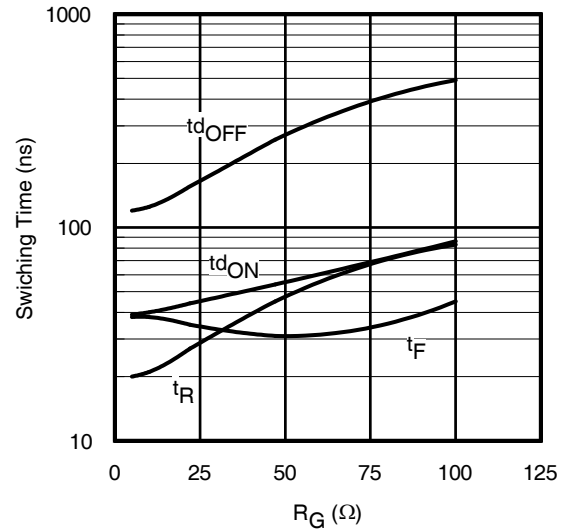
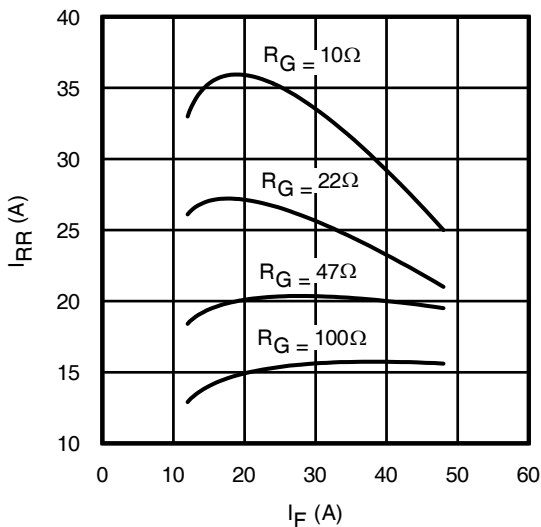
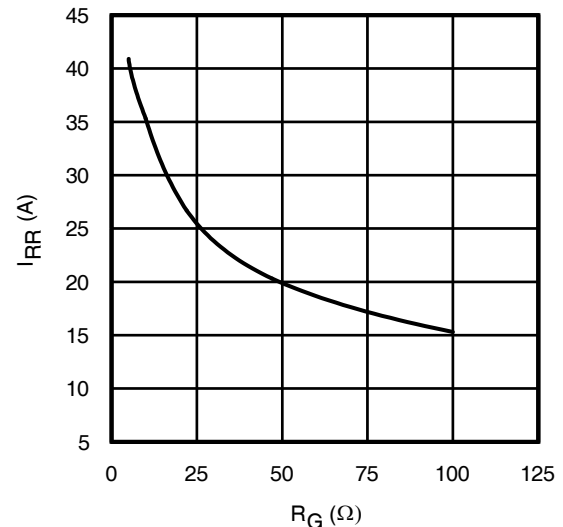
**Fig. 10 - Typical  $V_{CE}$  vs.  $V_{GE}$**   
 $T_J = 25^\circ\text{C}$

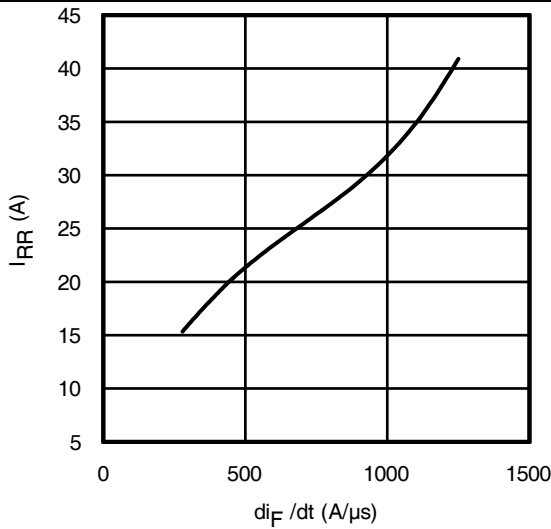


**Fig. 11 - Typical  $V_{CE}$  vs.  $V_{GE}$**   
 $T_J = 175^\circ\text{C}$

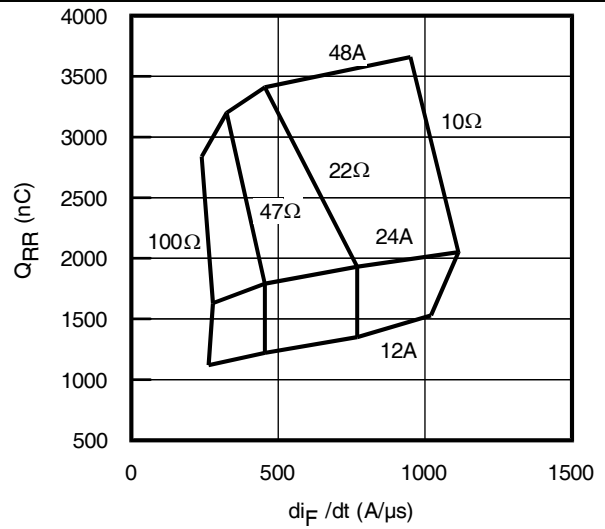


**Fig. 12 - Typ. Transfer Characteristics**  
 $V_{CE} = 50\text{V}$ ;  $t_p = 10\mu\text{s}$

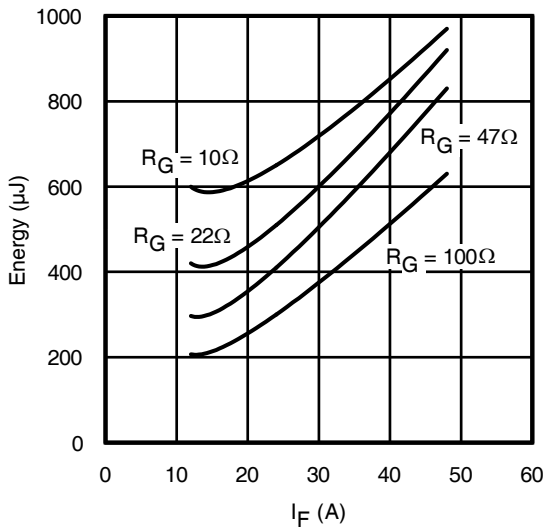

**Fig. 13 - Typ. Energy Loss vs.  $I_C$** 
 $T_J = 175^\circ\text{C}; L = 200\mu\text{H}; V_{CE} = 400\text{V}, R_G = 10\Omega; V_{GE} = 15\text{V}$ 

**Fig. 14 - Typ. Switching Time vs.  $I_C$** 
 $T_J = 175^\circ\text{C}; L = 200\mu\text{H}; V_{CE} = 400\text{V}, R_G = 10\Omega; V_{GE} = 15\text{V}$ 

**Fig. 15 - Typ. Energy Loss vs.  $R_G$** 
 $T_J = 175^\circ\text{C}; L = 200\mu\text{H}; V_{CE} = 400\text{V}, I_{CE} = 24\text{A}; V_{GE} = 15\text{V}$ 

**Fig. 16 - Typ. Switching Time vs.  $R_G$** 
 $T_J = 175^\circ\text{C}; L = 200\mu\text{H}; V_{CE} = 400\text{V}, I_{CE} = 24\text{A}; V_{GE} = 15\text{V}$ 

**Fig. 17 - Typ. Diode  $I_{RR}$  vs.  $I_F$**   
 $T_J = 175^\circ\text{C}$ 

**Fig. 18 Typ. Diode  $I_{RR}$  vs.  $R_G$**   
 $T_J = 175^\circ\text{C}$



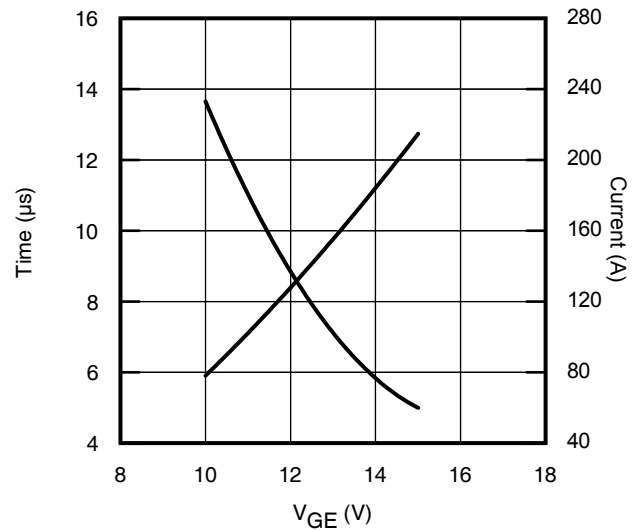
**Fig. 19** - Typ. Diode  $I_{RR}$  vs.  $dI_F/dt$   
 $V_{CC} = 400V$ ;  $V_{GE} = 15V$ ;  $I_F = 24A$ ;  $T_J = 175^\circ C$



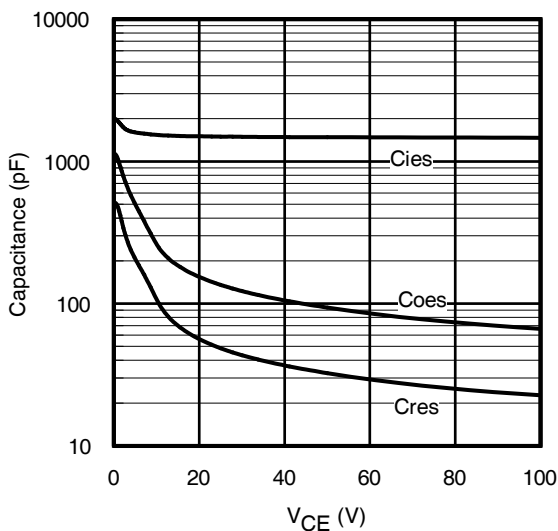
**Fig. 20** - Typ. Diode  $Q_{RR}$  vs.  $dI_F/dt$   
 $V_{CC} = 400V$ ;  $V_{GE} = 15V$ ;  $T_J = 175^\circ C$



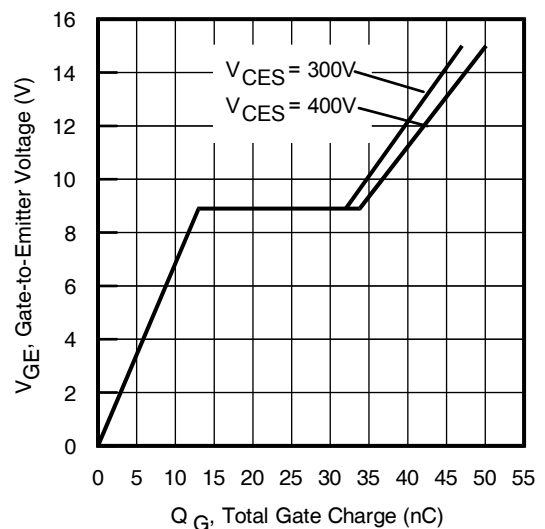
**Fig. 21** - Typ. Diode  $E_{RR}$  vs.  $I_F$   
 $T_J = 175^\circ C$



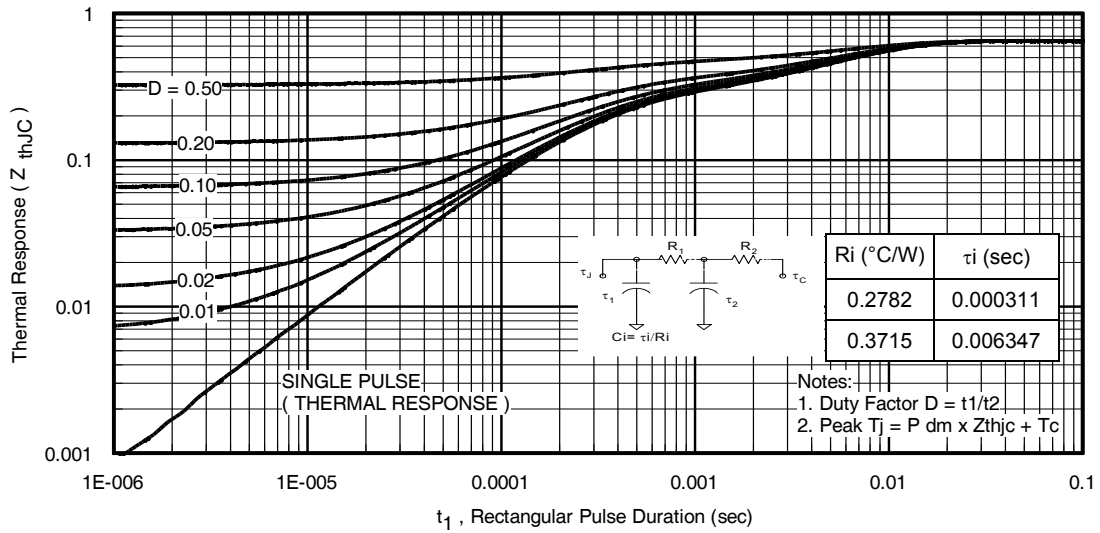
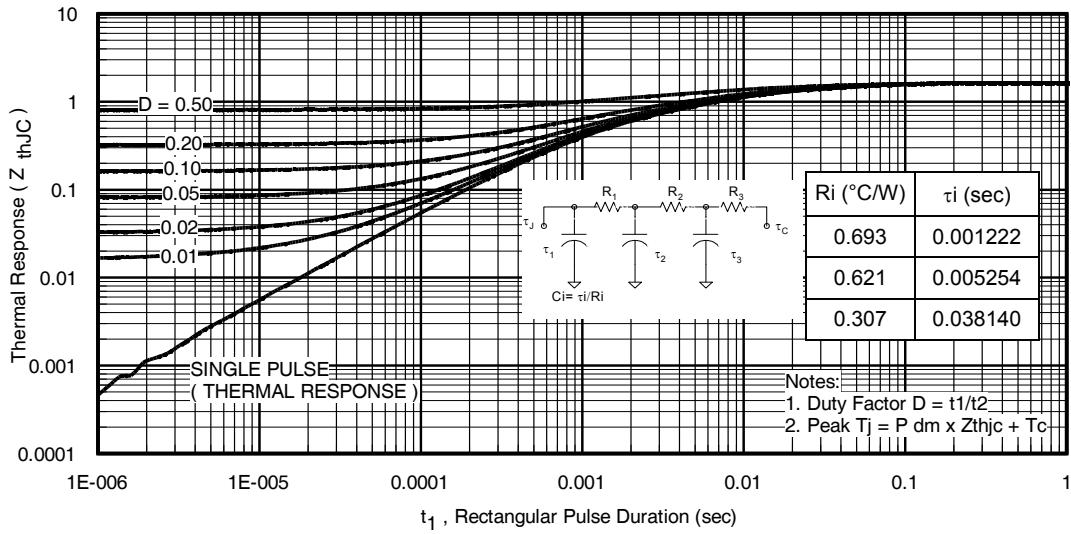
**Fig. 22** -  $V_{GE}$  vs. Short Circuit Time  
 $V_{CC} = 400V$ ;  $T_C = 25^\circ C$

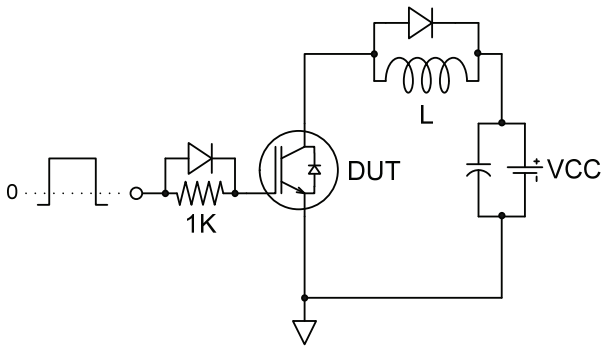
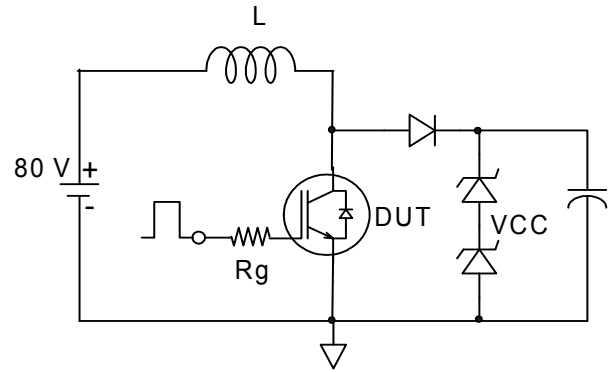
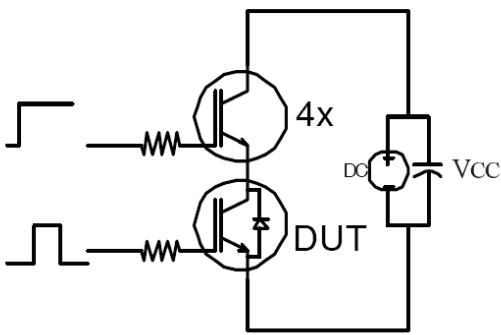
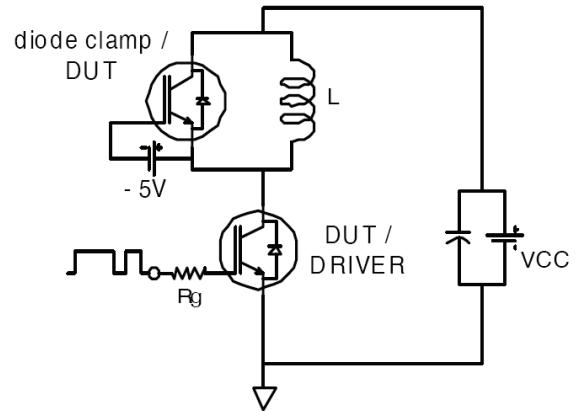
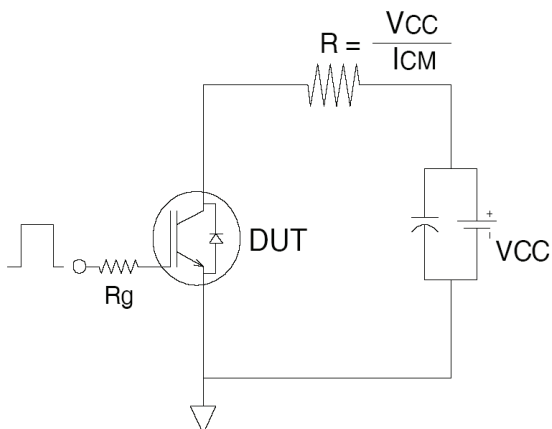
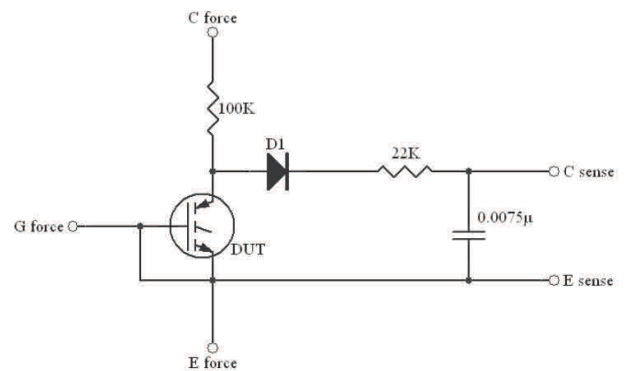


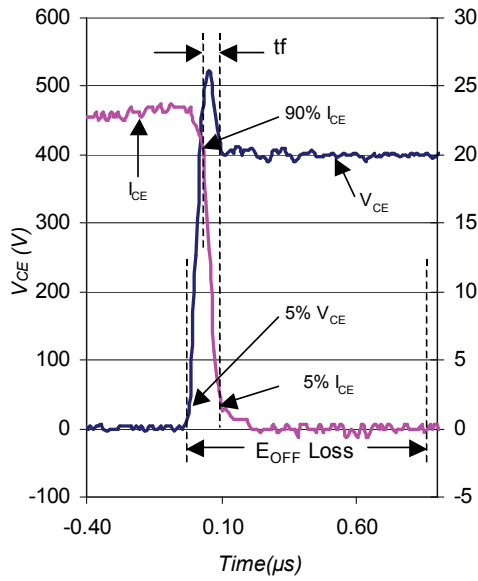
**Fig. 23** - Typ. Capacitance vs.  $V_{CE}$   
 $V_{GE} = 0V$ ;  $f = 1MHz$



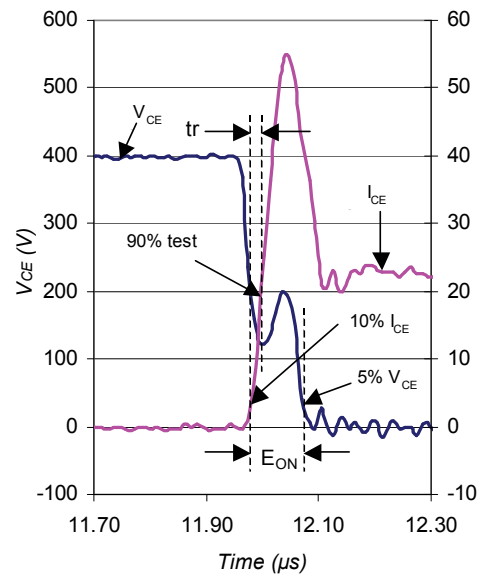
**Fig. 24** - Typical Gate Charge vs.  $V_{GE}$   
 $I_{CE} = 24A$ ;  $L = 600\mu H$


**Fig 25. Maximum Transient Thermal Impedance, Junction-to-Case (IGBT)**

**Fig 26. Maximum Transient Thermal Impedance, Junction-to-Case (DIODE)**

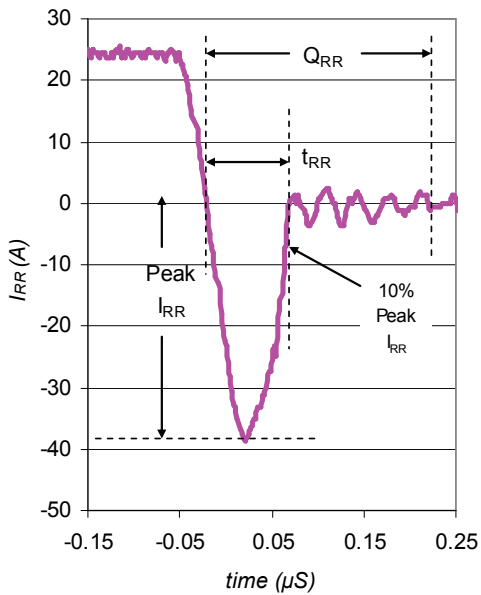

**Fig.C.T.1 - Gate Charge Circuit (turn-off)**

**Fig.C.T.2 - RBSOA Circuit**

**Fig.C.T.3 - S.C. SOA Circuit**

**Fig.C.T.4 - Switching Loss Circuit**

**Fig.C.T.5 - Resistive Load Circuit**

**Fig.C.T.6 - BVCES Filter Circuit**



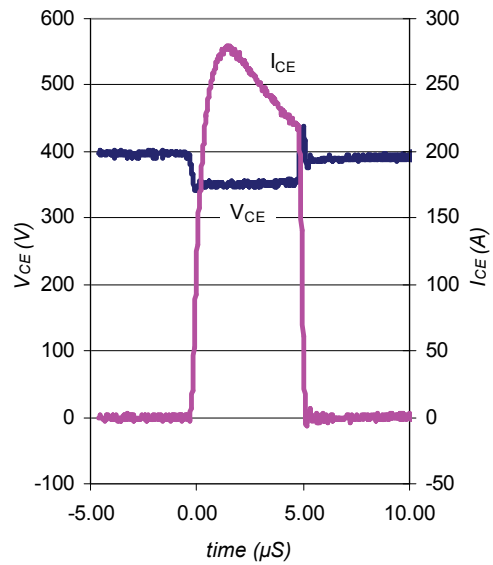
**Fig. WF1** - Typ. Turn-off Loss Waveform  
@  $T_J = 175^\circ\text{C}$  using Fig. CT.4



**Fig. WF2** - Typ. Turn-on Loss Waveform  
@  $T_J = 175^\circ\text{C}$  using Fig. CT.4



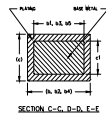
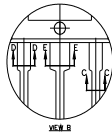
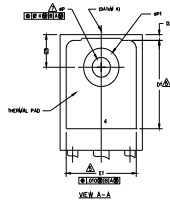
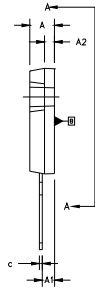
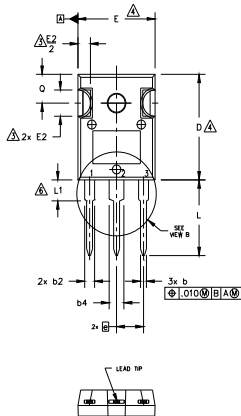
**Fig. WF3** - Typ. Diode Recovery Waveform  
@  $T_J = 175^\circ\text{C}$  using Fig. CT.4



**Fig. WF4** - Typ. S.C. Waveform  
@  $T_J = 25^\circ\text{C}$  using Fig. CT.3

## TO-247AC Package Outline

(Dimensions are shown in millimeters (inches))



**NOTES:**

1. DIMENSIONING AND TOLERANCING AS PER ASME Y14.5M 1994.
2. DIMENSIONS ARE SHOWN IN INCHES.
3. CONTOUR OF SLOT OPTIONAL.
4. DIMENSION D & E DO NOT INCLUDE MOLD FLASH. MOLD FLASH SHALL NOT EXCEED .005" (0.127) PER SIDE. THESE DIMENSIONS ARE MEASURED AT THE OUTERMOST EXTREMES OF THE PLASTIC BODY.
5. THERMAL PAD CONTOUR OPTIONAL WITHIN DIMENSIONS D1 & E1.
6. LEAD FINISH UNCONTROLLED IN L1.
7. ØP TO HAVE A MAXIMUM DRAFT ANGLE OF 1.5 ° TO THE TOP OF THE PART WITH A MAXIMUM HOLE DIAMETER OF .154 INCH.
8. OUTLINE CONFORMS TO JEDEC OUTLINE TO-247AC .

SYMBOL	DIMENSIONS				NOTES
	INCHES		MILLIMETERS		
	MIN.	MAX.	MIN.	MAX.	
A	.183	.209	4.65	5.31	
A1	.087	.102	2.21	2.59	
A2	.059	.098	1.50	2.49	
b	.039	.055	0.99	1.40	
b1	.039	.053	0.99	1.35	
b2	.065	.094	1.65	2.39	
b3	.065	.092	1.65	2.34	
b4	.102	.135	2.59	3.43	
b5	.102	.133	2.59	3.38	
c	.015	.035	0.38	0.89	4
c1	.015	.033	0.38	0.84	5
D	.776	.815	19.71	20.70	4
D1	.515	-	13.08	-	5
D2	.020	.053	0.51	1.35	
E	.602	.625	15.29	15.87	4
E1	.530	-	13.46	-	
E2	.178	.216	4.52	5.49	
e	.215 BSC		5.46 BSC		
Øk	.010		0.25		
L	.559	.634	14.20	16.10	
L1	.146	.169	3.71	4.29	
ØP	.140	.144	3.56	3.66	
ØP1	-	.291	-	7.39	
Q	.209	.224	5.31	5.69	
S	.217 BSC		5.51 BSC		

**LEAD ASSIGNMENTS**

**HEXFET**

- 1.- GATE
- 2.- DRAIN
- 3.- SOURCE
- 4.- DRAIN

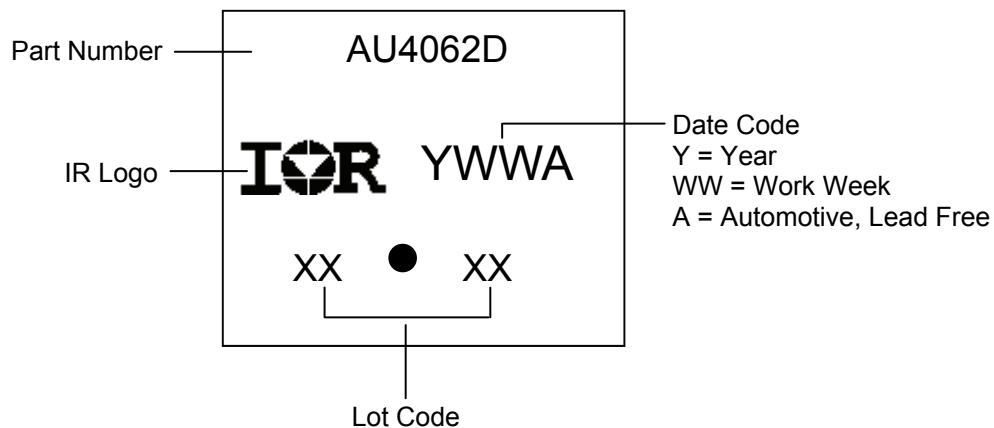
**IGBTs, CoPACK**

- 1.- GATE
- 2.- COLLECTOR
- 3.- EMITTER
- 4.- COLLECTOR

**DIODES**

- 1.- ANODE/OPEN
- 2.- CATHODE
- 3.- ANODE

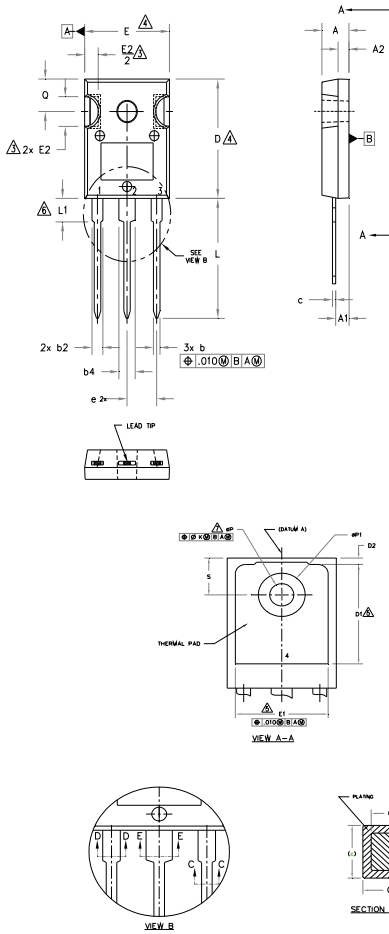
## TO-247AC Part Marking Information



TO-247AD package is not recommended for Surface Mount Application.

## TO-247AD Package Outline

(Dimensions are shown in millimeters (inches))



NOTES:

1. DIMENSIONING AND TOLERANCING AS PER ASME Y14.5M 1994.
2. DIMENSIONS ARE SHOWN IN INCHES.
3. CONTOUR OF SLOT OPTIONAL.
4. DIMENSION D & E DO NOT INCLUDE MOLD FLASH. MOLD FLASH SHALL NOT EXCEED .005" (0.127) PER SIDE. THESE DIMENSIONS ARE MEASURED AT THE OUTERMOST EXTREMES OF THE PLASTIC BODY.
5. THERMAL PAD CONTOUR OPTIONAL WITHIN DIMENSIONS D1 & E1.
6. LEAD FINISH UNCONTROLLED IN L1.
7.  $\phi P$  TO HAVE A MAXIMUM DRAFT ANGLE OF 1.5 ° TO THE TOP OF THE PART WITH A MAXIMUM HOLE DIAMETER OF .154 INCH.
8. OUTLINE CONFORMS TO JEDEC OUTLINE TO-247AD.

SYMBOL	DIMENSIONS				NOTES
	INCHES		MILLIMETERS		
	MIN.	MAX.	MIN.	MAX.	
A	.190	.203	4.83	5.13	
A1	.087	.102	2.21	2.59	
A2	.059	.098	1.50	2.49	
b	.039	.055	0.99	1.40	
b1	.039	.053	0.99	1.35	
b2	.065	.094	1.65	2.39	
b3	.065	.092	1.65	2.34	
b4	.102	.135	2.59	3.43	
b5	.102	.133	2.59	3.38	
c	.015	.035	0.38	0.89	
c1	.015	.033	0.38	0.84	
D	.776	.815	19.71	20.70	4
D1	.515	-	13.08	-	5
D2	.020	.053	0.51	1.35	
E	.602	.625	15.29	15.87	4
E1	.530	-	13.46	-	
E2	.178	.216	4.52	5.49	
e	.215 BSC		5.46 BSC		
$\phi k$	.010		0.25		
L	.780	.827	19.57	21.00	
L1	.146	.169	3.71	4.29	
$\phi P$	.140	.144	3.56	3.66	
$\phi P1$	-	.291	-	7.39	
Q	.209	.224	5.31	5.69	
S	.217 BSC		5.51 BSC		

LEAD ASSIGNMENTS

HEXFET

- 1.- GATE
- 2.- DRAIN
- 3.- SOURCE
- 4.- DRAIN

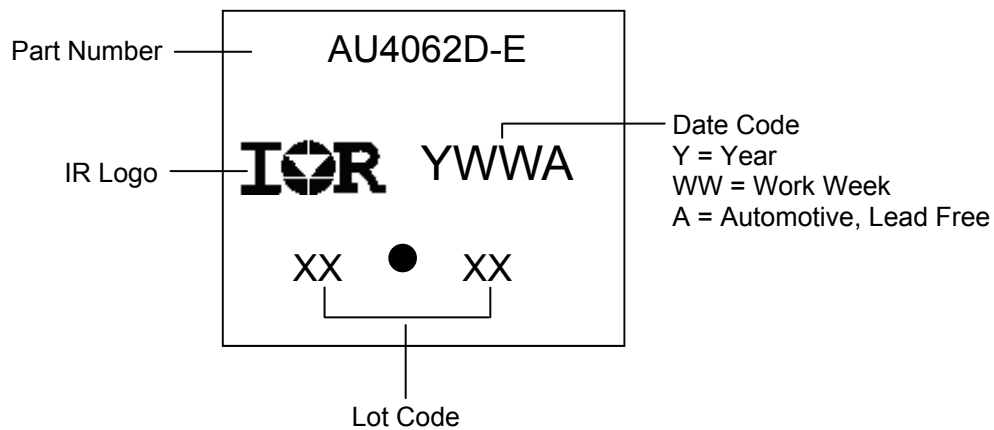
IGBTs, CoPACK

- 1.- GATE
- 2.- COLLECTOR
- 3.- EMITTER
- 4.- COLLECTOR

DIODES

- 1.- ANODE/OPEN
- 2.- CATHODE
- 3.- ANODE

## TO-247AD Part Marking Information



TO-247AD package is not recommended for Surface Mount Application.

**Qualification Information**

<b>Qualification Level</b>		Automotive (per AEC-Q101)	
		This part number(s) passed Automotive qualification. Infineon's Industrial and Consumer qualification level is granted by extension of the higher Automotive level.	
<b>Moisture Sensitivity Level</b>		TO-247AC	N/A
		TO-247AD	
<b>ESD</b>	Machine Model	Class M4(+/- 400V) <sup>†</sup> AEC-Q101-002	
	Human Body Model	Class H2(+/- 2000V) <sup>†</sup> AEC-Q101-001	
	Charged Device Model	Class C5 (+/- 1000V) <sup>†</sup> AEC-Q101-005	
<b>RoHS Compliant</b>		Yes	

† Highest passing voltage.

**Revision History**

Date	Comments
8/24/2017	<ul style="list-style-type: none"> <li>Updated datasheet with corporate template</li> <li>Corrected package outline –TO-247AD on page 11</li> <li>Corrected part marking on pages 10,11</li> </ul>

**Published by**

**Infineon Technologies AG**  
81726 München, Germany

© Infineon Technologies AG 2015

All Rights Reserved.

**IMPORTANT NOTICE**

The information given in this document shall in no event be regarded as a guarantee of conditions or characteristics ("Beschaffenheitsgarantie"). With respect to any examples, hints or any typical values stated herein and/or any information regarding the application of the product, Infineon Technologies hereby disclaims any and all warranties and liabilities of any kind, including without limitation warranties of non-infringement of intellectual property rights of any third party.

In addition, any information given in this document is subject to customer's compliance with its obligations stated in this document and any applicable legal requirements, norms and standards concerning customer's products and any use of the product of Infineon Technologies in customer's applications.

The data contained in this document is exclusively intended for technically trained staff. It is the responsibility of customer's technical departments to evaluate the suitability of the product for the intended application and the completeness of the product information given in this document with respect to such application.

For further information on the product, technology, delivery terms and conditions and prices please contact your nearest Infineon Technologies office ([www.infineon.com](http://www.infineon.com)).

**WARNINGS**

Due to technical requirements products may contain dangerous substances. For information on the types in question please contact your nearest Infineon Technologies office.

Except as otherwise explicitly approved by Infineon Technologies in a written document signed by authorized representatives of Infineon Technologies, Infineon Technologies' products may not be used in any applications where a failure of the product or any consequences of the use thereof can reasonably be expected to result in personal injury.