

Smart Lowside Power Switch

HITFET® BSP 75N



Data Sheet Rev. 1.4

Features

- Logic Level Input
- Input protection (ESD)
- Thermal shutdown with auto restart
- Overload protection
- Short circuit protection
- Overvoltage protection
- Current limitation
- Green Product (RoHS compliant)
- AEC Stress Test Qualification

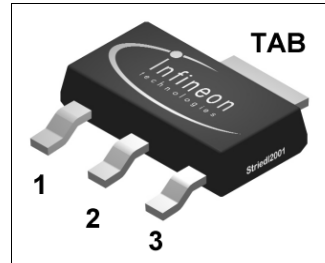

Application

- All kinds of resistive, inductive and capacitive loads in switching applications
- μC compatible power switch for 12 V and 24 V DC applications and for 42 Volt Powernet
- Replaces electromechanical relays and discrete circuits

General Description

N channel vertical power FET in Smart Power Technology. Fully protected by embedded protection functions.

Type	Ordering Code	Package
HITFET® BSP 75N	on request	PG-SOT223-4

Product Summary

Parameter	Symbol	Value	Unit
Continuous drain source voltage	V_{DS}	60	V
On-state resistance	$R_{\text{DS(ON)}}$	550	$\text{m}\Omega$
Current limitation	$I_{\text{D(lim)}}$	1	A
Nominal load current	$I_{\text{D(Nom)}}$	0.7	A
Clamping energy	E_{AS}	550	mJ

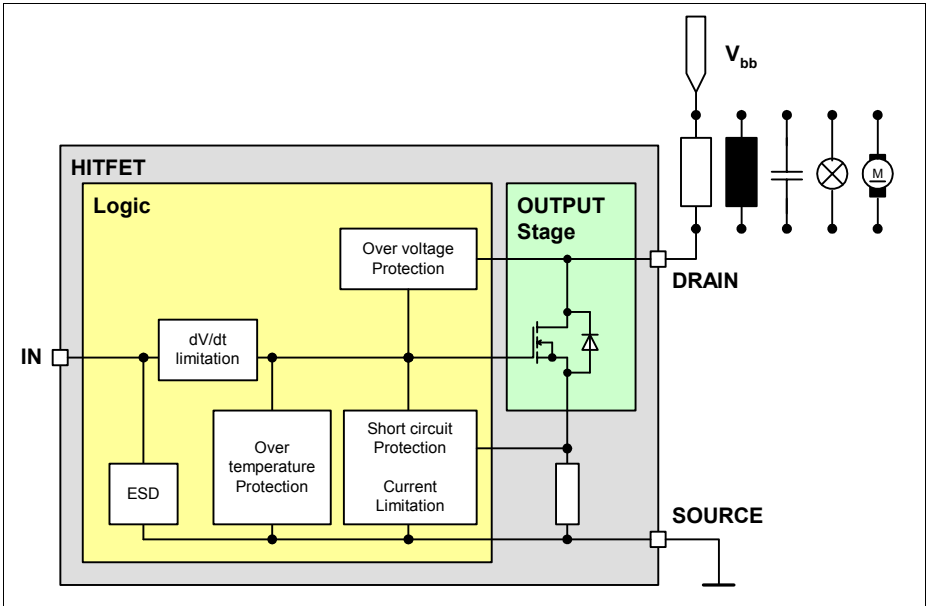

Figure 1 Block Diagram

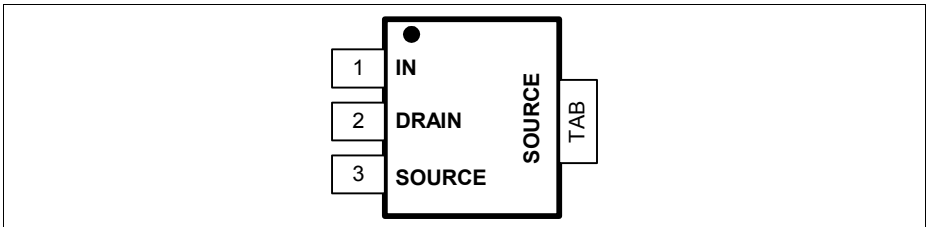

Figure 2 Pin Configuration

Pin Definitions and Functions

Pin No.	Symbol	Function
1	IN	Input ; activates output and supplies internal logic
2	DRAIN	Output to the load
3 + TAB	SOURCE	Ground ; pin3 and TAB are internally connected

Circuit Description

The BSP 75N is a monolithic power switch in Smart Power Technology (SPT) with a logic level input, an open drain DMOS output stage and integrated protection functions. It is designed for all kind of resistive and inductive loads (relays, solenoid) in automotive and industrial applications.

Protection Functions

- **Over voltage protection:** An internal clamp limits the output voltage at $V_{DS(AZ)}$ (min. 60V) when inductive loads are switched off.
- **Current limitation:** By means of an internal current measurement the drain current is limited at $I_{D(lim)}$ (1.4 - 1.5 A typ.). If the current limitation is active the device operates in the linear region, so power dissipation may exceed the capability of the heatsink. This operation leads to an increasing junction temperature until the over temperature threshold is reached.
- **Over temperature and short circuit protection:** This protection is based on sensing the chip temperature. The location of the sensor ensures a fast and accurate junction temperature detection. Over temperature shutdown occurs at minimum 150 °C. A hysteresis of typ. 10 K enables an automatic restart by cooling.

The device is ESD protected according Human Body Model (4 kV) and load dump protected (see Maximum Ratings).

Absolute Maximum Ratings
 $T_j = 25\text{ °C}$, unless otherwise specified

Parameter	Symbol	Values	Unit	Remarks
Continuous drain source voltage ¹⁾	V_{DS}	60	V	–
Drain source voltage for short circuit protection	V_{DS}	36	V	–
Continuous input voltage	V_{IN}	-0.2 ... +10	V	–
Peak input voltage	V_{IN}	-0.2 ... +20	V	–
Continuous Input Current -0.2V ≤ V_{IN} ≤ 10V V_{IN} < -0.2V or V_{IN} > 10V	I_{IN}	no limit I_{IN} ≤ 2mA	mA	–
Operating temperature range	T_j	-40 ... +150	°C	–
Storage temperature range	T_{stg}	-55 ... +150	°C	–
Power dissipation (DC)	P_{tot}	1.8	W	–
Unclamped single pulse inductive energy	E_{AS}	550	mJ	$I_{D(ISO)} = 0.7\text{ A}$; $V_{bb} = 32\text{ V}$
Load dump protection ²⁾ IN = low or high (8 V); $R_L = 50\ \Omega$ IN = high (8 V); $R_L = 22\ \Omega$	$V_{LoadDump}$	80 47	V	$V_{LoadDump} = V_P + V_S$; $V_P = 13.5\text{ V}$ $R_l^{3)} = 2\ \Omega$; $t_d = 400\text{ ms}$;
Electrostatic discharge voltage (Human Body Model) according to MIL STD 883D, method 3015.7 and EOS/ESD assn. standard S5.1 - 1993	V_{ESD}	4000	V	–

Thermal Resistance

Junction soldering point	R_{thJS}	≤ 10	K/W	–
Junction - ambient ⁴⁾	R_{thJA}	≤ 70	K/W	–

¹⁾ See also [Figure 7](#) and [Figure 10](#).

²⁾ $V_{LoadDump}$ is setup without DUT connected to the generator per ISO 7637-1 and DIN 40 839. See also [page 7](#).

³⁾ R_l = internal resistance of the load dump test pulse generator LD200.

⁴⁾ Device on epoxy pcb 40 mm × 40 mm × 1.5 mm with 6 cm² copper area for pin 4 connection.

Electrical Characteristics
 $T_j = 25\text{ °C}$, unless otherwise specified

Parameter	Symbol	Limit Values			Unit	Test Conditions
		min.	typ.	max.		

Static Characteristics

Drain source clamp voltage	$V_{DS(AZ)}$	60	–	75	V	$I_D = 10\text{ mA}$, $T_j = -40 \dots +150\text{ °C}$
Off state drain current	I_{DSS}	–	–	5	μA	$V_{IN} = 0\text{ V}$, $V_{DS} = 32\text{ V}$, $T_j = -40 \dots +150\text{ °C}$
Input threshold voltage	$V_{IN(th)}$	1	1.8	2.5	V	$I_D = 10\text{ mA}$
Input current: normal operation, $I_D < I_{D(lim)}$; current limitation mode, $I_D = I_{D(lim)}$; After thermal shutdown, $I_D = 0\text{ A}$:	$I_{IN(1)}$ $I_{IN(2)}$ $I_{IN(3)}$	– – 1000	100 250 1500	200 400 2000	μA	$V_{IN} = 5\text{ V}$
On-state resistance $T_j = 25\text{ °C}$ $T_j = 150\text{ °C}$	$R_{DS(on)}$	– –	490 850	675 1350	$\text{m}\Omega$	$I_D = 0.7\text{ A}$, $V_{IN} = 5\text{ V}$
On-state resistance $T_j = 25\text{ °C}$ $T_j = 150\text{ °C}$	$R_{DS(on)}$	– –	430 750	550 1000	$\text{m}\Omega$	$I_D = 0.7\text{ A}$, $V_{IN} = 10\text{ V}$
Nominal load current	$I_{D(Nom)}$	0.7	–	–	A	$V_{BB} = 12\text{ V}$, $V_{DS} = 0.5\text{ V}$, $T_S = 85\text{ °C}$, $T_j < 150\text{ °C}$
Current limit	$I_{D(lim)}$	1	1.5	1.9	A	$V_{IN} = 10\text{ V}$, $V_{DS} = 12\text{ V}$

Dynamic Characteristics ¹⁾

Turn-on time	V_{IN} to 90% I_D :	t_{on}	–	10	20	μs	$R_L = 22\ \Omega$, $V_{IN} = 0$ to 10 V, $V_{BB} = 12\text{ V}$
Turn-off time	V_{IN} to 10% I_D :	t_{off}	–	10	20	μs	$R_L = 22\ \Omega$, $V_{IN} = 10$ to 0 V, $V_{BB} = 12\text{ V}$

Electrical Characteristics (cont'd)
 $T_j = 25\text{ °C}$, unless otherwise specified

Parameter	Sym- bol	Limit Values			Unit	Test Conditions
		min.	typ.	max.		
Slew rate on 70 to 50% V_{BB} :	$-dV_{DS}/dt_{on}$	–	5	10	V/ μ s	$R_L = 22\ \Omega$, $V_{IN} = 0$ to 10 V, $V_{BB} = 12\text{ V}$
Slew rate off 50 to 70% V_{BB} :	dV_{DS}/dt_{off}	–	10	15	V/ μ s	$R_L = 22\ \Omega$, $V_{IN} = 10$ to 0 V, $V_{BB} = 12\text{ V}$

Protection Functions²⁾

Thermal overload trip temperature	T_{jt}	150	165	180	$^{\circ}\text{C}$	–
Thermal hysteresis	ΔT_{jt}	–	10	–	K	–
Unclamped single pulse inductive energy	E_{AS}	550	–	–	mJ	$I_{D(ISO)} = 0.7\text{ A}$, $V_{BB} = 32\text{ V}$
	$T_j = 25\text{ °C}$	200	–	–		
	$T_j = 150\text{ °C}$					

Inverse Diode

Continuous source drain voltage	V_{SD}	–	1	–	V	$V_{IN} = 0\text{ V}$, $-I_D = 2 \times 0.7\text{ A}$
---------------------------------	----------	---	---	---	---	---

¹⁾ See also [Figure 9](#).

²⁾ Integrated protection functions are designed to prevent IC destruction under fault conditions described in the datasheet. Fault conditions are considered as “outside” normal operating range. Protection functions are not designed for continuous, repetitive operation.

EMC-Characteristics

The following EMC-Characteristics outline the behavior of typical devices. They are not part of any production test.

Table 1 Test Conditions

Parameter	Symbol	Value	Unit	Remark
Temperature	T_A	23 ±5	°C	–
Supply Voltage	V_S	13.5	V	–
Load	R_L	27	Ω	ohmic
Operation mode	PWM DC	– –	– –	$f_{INx}=100\text{Hz}$, $D=0.5$ ON / OFF
DUT specific	$V_{IN}(\text{'HIGH'})=5\text{V}$			

Fast electrical transients

acc. to ISO 7637

Test ¹⁾ Pulse	Max. Test Level	Test Result		Pulse Cycle Time and Generator Impedance
		OUT _x stressed		
		ON	OFF	
1	-200V	C	C	500ms ; 10Ω
2	+200V	C	C	500ms ; 10Ω
3a	-200V	C	C	100ms ; 50Ω
3b	+200V	C	C	100ms ; 50Ω
4	-7V	C	C	0.01Ω
5	175V	E(65V)	E(75V)	400ms ; 2Ω

¹⁾ The test pulses are applied at V_S

Definition of functional status

Class	Content
C	All functions of the device are performed as designed after exposure to disturbance.
E	One or more function of a device does not perform as designed after exposure and can not be returned to proper operation without repairing or replacing the device. The value after the character shows the limit.

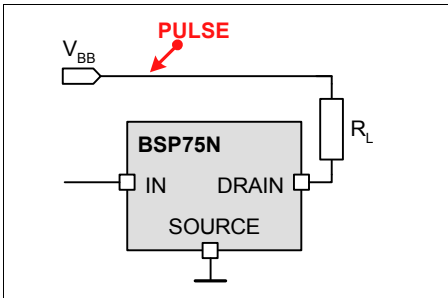

Figure 3 Test circuit for ISO pulse

Conducted Emissions

Acc. IEC 61967-4 (1Ω/150Ω method)

Typ. V_{bb} Emissions at PWM-mode with 150Ω-matching network

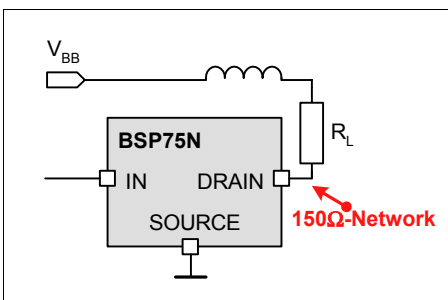
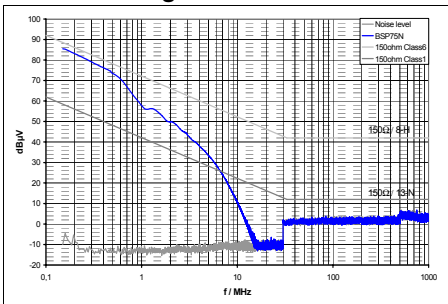

Figure 4 Test circuit for conducted emission 1)

Conducted Susceptibility

Acc. 47A/658/CD IEC 62132-4 (Direct Power Injection)

Direct Power Injection: Forward Power CW

Failure Criteria: Amplitude or frequency variation max. 10% at OUT

Typ. V_{bb} Susceptibility at DC-ON/OFF and at PWM

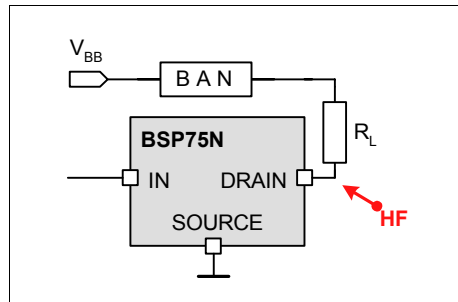
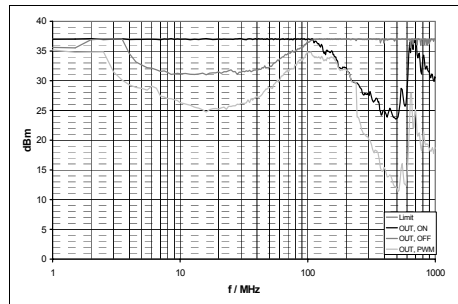

Test circuit for conducted susceptibility 2)

- 1) For defined de coupling and high reproducibility a defined choke (5µH at 1MHz) is inserted in the V_{bb}-Line.
- 2) Broadband Artificial Network (short: BAN) consists of the same choke (5µH at 1MHz) and the same 150 Ohm-matching network as for emission measurement for defined de coupling and high reproducibility.

Block diagram

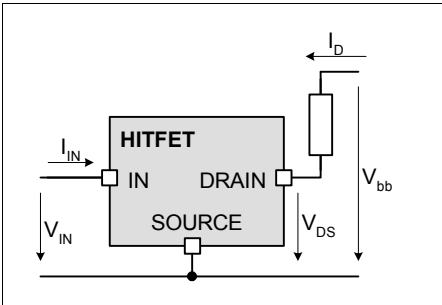

Figure 5 Terms

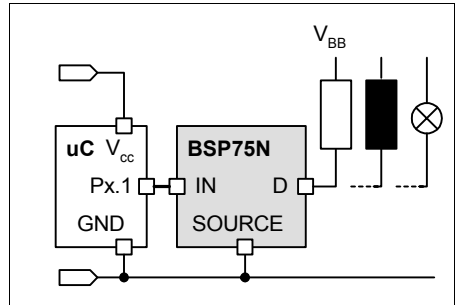

Figure 8 Application Circuit

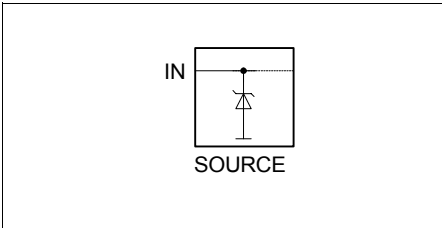

Figure 6 Input Circuit (ESD protection)

ESD zener diodes are not designed for DC current.

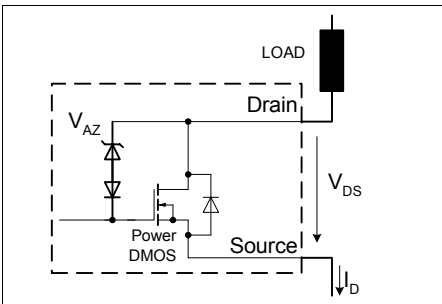

Figure 7 Inductive and Over voltage Output Clamp

Timing diagrams

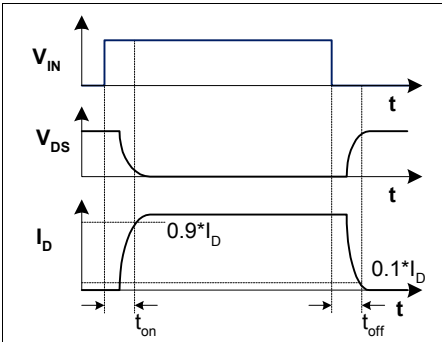

Figure 9 Switching a Resistive Load

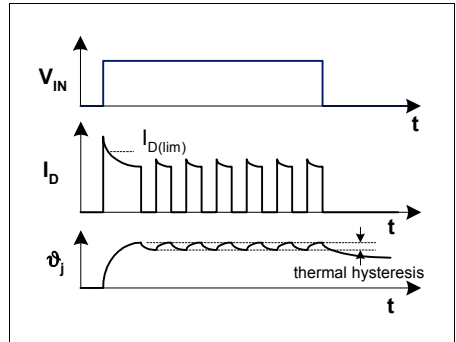

Figure 11 Short circuit

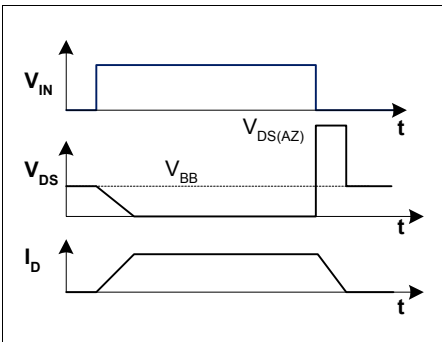
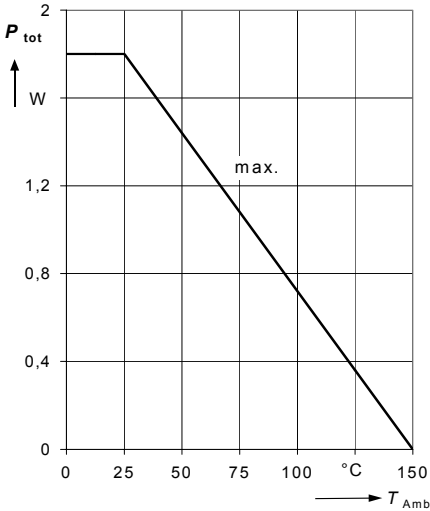

Figure 10 Switching an Inductive Load

1 Max. allowable power dissipation

$$P_{\text{tot}} = f(T_{\text{Amb}})$$

2 On-state resistance $R_{\text{ON}} = f(T_j)$;

$$I_D = 0.7 \text{ A}; V_{\text{IN}} = 10 \text{ V}$$

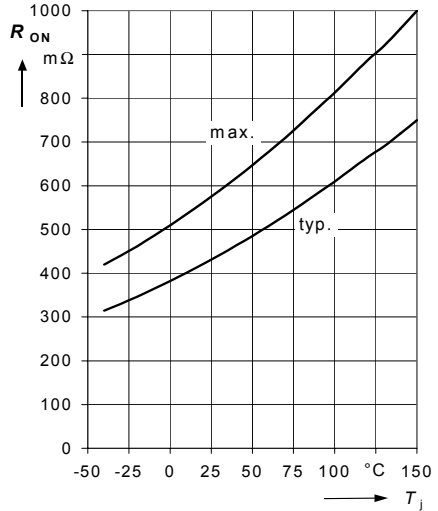

3 On-state resistance $R_{\text{ON}} = f(T_j)$;

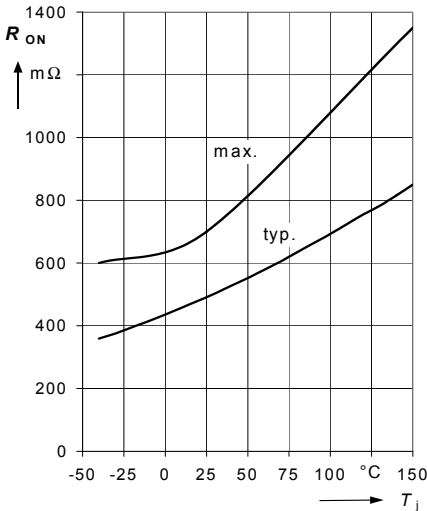
$$I_D = 0.7 \text{ A}; V_{\text{IN}} = 5 \text{ V}$$

4 Typ. input threshold voltage

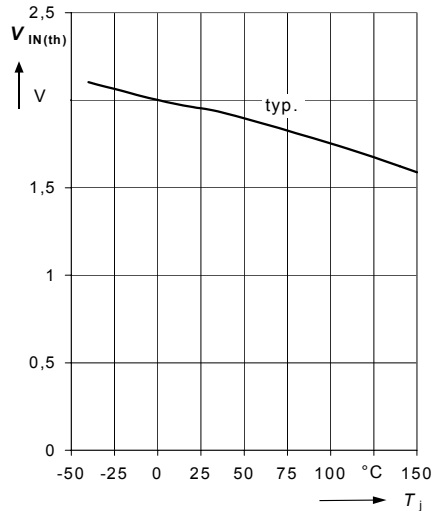
$$V_{\text{IN(th)}} = f(T_j); I_D = 10 \text{ mA}; V_{\text{DS}} = 12 \text{ V}$$

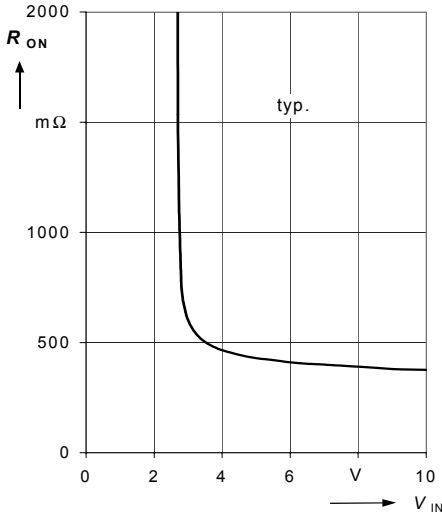
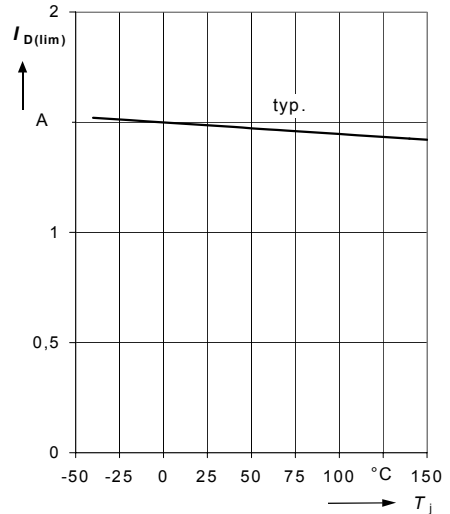
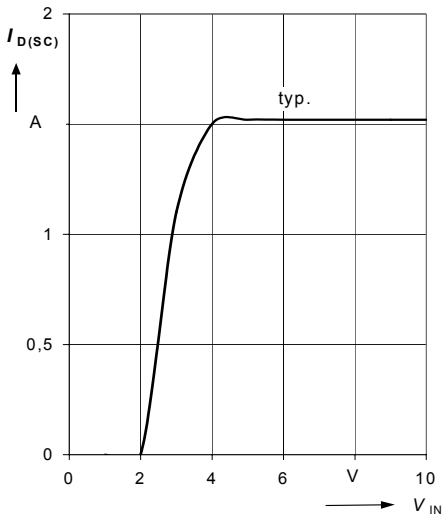
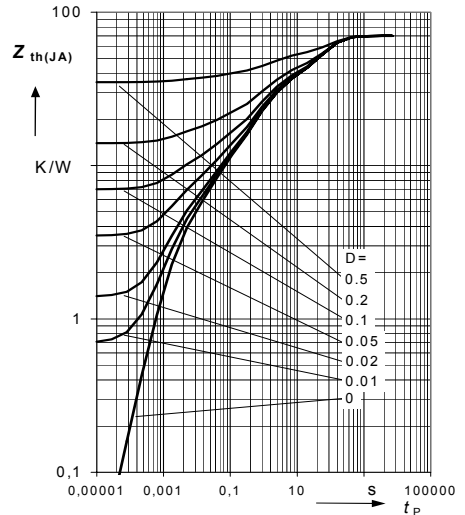

5 Typ. on-state resistance $R_{ON} = f(V_{IN})$;
 $I_D = 0.7 \text{ A}; T_j = 25 \text{ }^\circ\text{C}$

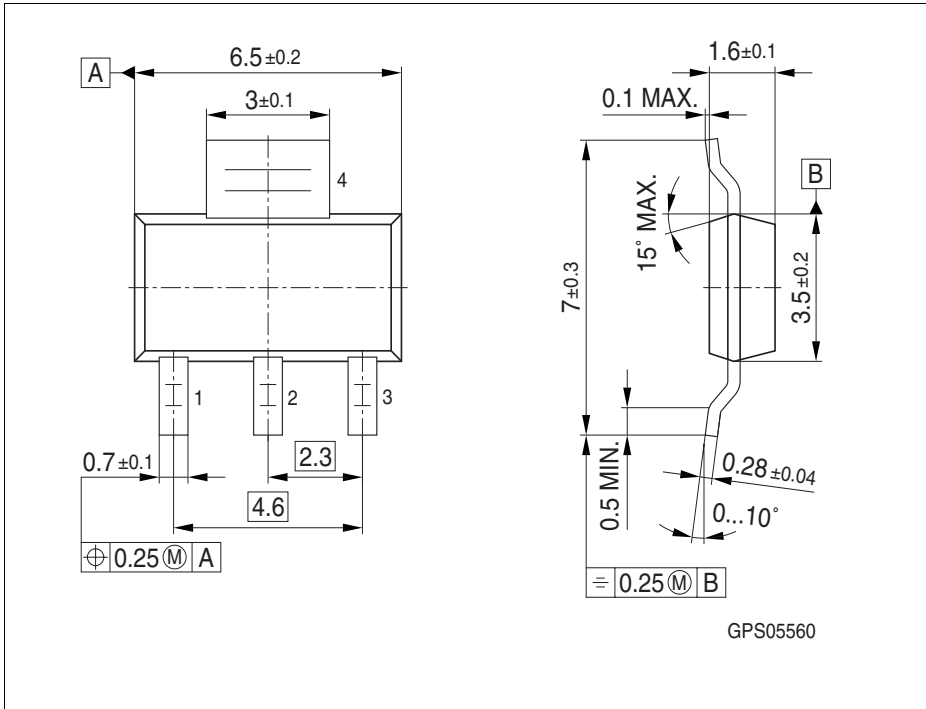
6 Typ. current limitation $I_{D(lim)} = f(T_j)$;
 $V_{DS} = 12 \text{ V}, V_{IN} = 10 \text{ V}$

7 Typ. short circuit current
 $I_{D(SC)} = f(V_{IN}); V_{DS} = 12 \text{ V}, T_j = 25 \text{ }^\circ\text{C}$

8 Max. transient thermal impedance
 $Z_{thJA} = f(t_p) @ 6\text{cm}^2$; Parameter: $D = t_p/T$

1 Package Outlines HITFET® BSP 75N

Figure 12 PG-SOT223-4 (Plastic Green Small Outline Transistor Package)
Green Product (RoHS compliant)

To meet the world-wide customer requirements for environmentally friendly products and to be compliant with government regulations the device is available as a green product. Green products are RoHS-Compliant (i.e Pb-free finish on leads and suitable for Pb-free soldering according to IPC/JEDEC J-STD-020).

Please specify the package needed (e.g. green package) when placing an order

You can find all of our packages, sorts of packing and others in our Infineon Internet Page: <http://www.infineon.com/packages>.

Dimensions in mm

Edition 2008-07-10

**Published by Infineon Technologies AG,
81726 Munich, Germany**

**© Infineon Technologies AG 2008.
All Rights Reserved.**

Legal Disclaimer

The information given in this document shall in no event be regarded as a guarantee of conditions or characteristics ("Beschaffenheitsgarantie"). With respect to any examples or hints given herein, any typical values stated herein and/or any information regarding the application of the device, Infineon Technologies hereby disclaims any and all warranties and liabilities of any kind, including without limitation warranties of non-infringement of intellectual property rights of any third party.

Information

For further information on technology, delivery terms and conditions and prices please contact your nearest Infineon Technologies Office (www.infineon.com)

Warnings

Due to technical requirements components may contain dangerous substances. For information on the types in question please contact your nearest Infineon Technologies Office.

Infineon Technologies Components may only be used in life-support devices or systems with the express written approval of Infineon Technologies, if a failure of such components can reasonably be expected to cause the failure of that life-support device or system, or to affect the safety or effectiveness of that device or system. Life support devices or systems are intended to be implanted in the human body, or to support and/or maintain and sustain and/or protect human life. If they fail, it is reasonable to assume that the health of the user or other persons may be endangered.