

BTS50025-1TEA

Smart High-Side Power Switch



1 Overview

Features

- One channel device
- Low Stand-by current
- Current controlled input
- Reverse battery protection
- Electrostatic discharge protection (ESD)
- Optimized Electromagnetic Compatibility (EMC)
- Compatible to cranking pulses (Severe cold start E11 in LV124)
- Embedded diagnostic functions
- Embedded protection functions
- Green Product (RoHS compliant)

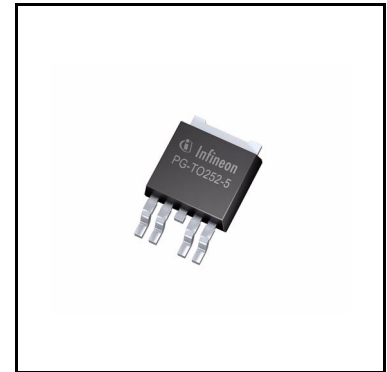

Applications

- Suitable for resistive, inductive and capacitive loads
- Replaces electromechanical relays, fuses and discrete circuits
- Most suitable for application with high current loads, such heating system, fan and pump
- PWM applications with low frequency

Product validation

Qualified for automotive applications. Product validation according to AEC-Q100.

Description

The BTS50025-1TEA is a 2.5mΩ single channel Smart High-Side Power Switch, embedded in a PG-TO-252-5-11 package, providing protective functions and diagnosis. It contains Infineon® ReverSave™ functionality. The power transistor is built by an N-channel MOSFET with charge pump. It is specially designed to drive high current loads up to 65A, for application like heaters, glow plugs, fan and pump in the harsh automotive environment.

Overview

Table 1 Product Summary

Parameter	Symbol	Values
Operating Voltage	$V_{S(OP)}$	5.8 V ... 18 V
Extended supply voltage range	$V_{S(EXT)}$	3.1 V ... 27 V
Maximum ON-State Resistance ($T_j = 150\text{ °C}$)	$R_{DS(ON)}$	5 m Ω
Nominal Load Current ($T_A = 85\text{ °C}$)	$I_{L(NOM)}$	24 A
Typical current sense differential ratio	dk_{ILIS}	18000
Minimum short circuit current threshold	$I_{CL(0)}$	65 A
Maximum reverse battery voltage	$-V_{S(REV)}$	-16 V
Maximum Stand-by Current at $T_j = 25\text{ °C}$	$I_{vs(off)}$	4 μ A

Embedded Diagnostic Functions

- Proportional load current sense
- Short circuit / Overtemperature detection
- Latched status signal after short circuit or overtemperature detection

Embedded Protection Functions

- Infineon[®] ReverSave™: Reverse battery protection by self turn ON of power MOSFET
- Short circuit protection with latch
- Overtemperature protection with latch
- Enhanced short circuit operation
- Infineon[®] SMART CLAMPING

Type	Package	Marking
BTS50025-1TEA	PG-TO-252-5-11	S50025A

Table of Contents

1	Overview	1
	Features	1
	Applications	1
	Product validation	1
	Description	1
	Table of Contents	3
	List of Tables	5
	List of Figures	6
2	Block Diagram	7
3	Pin Configuration	8
3.1	Pin Assignment	8
3.2	Pin Definitions and Functions	8
3.3	Voltage and Current Definition	9
4	General Product Characteristics	10
4.1	Absolute Maximum Ratings	10
4.2	Functional Range	13
4.3	Thermal Resistance	14
5	Functional Description	15
5.1	Power Stage	15
5.1.1	Output ON-State Resistance	15
5.1.2	Switching Resistive Loads	15
5.1.3	Switching Inductive Loads	15
5.1.3.1	Output Clamping	15
5.1.3.2	Maximum Load Inductance	17
5.1.4	PWM Switching	18
5.1.5	Advanced switch-off behavior	18
5.2	Input Pins	19
5.2.1	Input Circuitry	19
5.3	Protection Functions	19
5.3.1	Overload Protection	20
5.3.1.1	Activation of the Switch into Short Circuit (Short Circuit Type 1)	20
5.3.1.2	Short Circuit Appearance when the Device is already ON (Short Circuit Type 2)	20
5.3.1.3	Over-power shutdown (PSD)	20
5.3.2	Temperature Limitation in the Power DMOS	21
5.4	Diagnostic Functions	22
5.4.1	IS Pin	22
5.4.2	SENSE Signal in Different Operation Modes	23
5.4.3	SENSE Signal in the Nominal Current Range	23
5.4.3.1	SENSE Signal Variation and Calibration	25
5.4.3.2	SENSE Signal Timing	27
5.4.3.3	SENSE Signal in Case of Short Circuit to V_S	27
5.4.3.4	SENSE Signal in Case of Over Load	27

6	Electrical Characteristics BTS50025-1TEA	29
6.1	Electrical Characteristics Table	29
6.2	Typical Performance Characteristics	35
7	Application Information	40
7.1	Further Application Information	41
8	Package Information	42
9	Revision History	43

List of Tables

Table 1	Product Summary	2
Table 2	Absolute Maximum Ratings	10
Table 3	Functional Range	13
Table 4	Thermal Resistance	14
Table 5-1	Sense Signal, Function of Operation Mode	23
Table 6-1	Electrical Characteristics: BTS50025-1TEA	29
Table 7-1	Bill of material	41

List of Figures

Figure 2-1	Block Diagram for the BTS50025-1TEA	7
Figure 2-2	Internal diode diagram	7
Figure 3-1	Pin Configuration	8
Figure 3-2	Voltage and Current Definition	9
Figure 1	Maximum Energy Dissipation for Inductive Switch OFF, $E_{AS/AR}$ vs. I_L at $V_S = 13.5\text{ V}$	12
Figure 2	Maximum Energy Dissipation Repetitive Pulse temperature derating	12
Figure 3	Typical Transient Thermal Impedance $Z_{th(JA)} = f(\text{time})$ for Different PCB Conditions	14
Figure 5-1	Switching a Resistive Load: Timing	15
Figure 5-2	Output Clamp	16
Figure 5-3	Switching an Inductance	16
Figure 5-4	Switching in PWM	18
Figure 5-5	Input Pin Circuitry	19
Figure 5-6	Diagram of Diagnosis & Protection Block	20
Figure 5-7	Over Power Shutdown behavior at low voltage	21
Figure 5-8	Behavior of the BTS50025-1TEA during PWM operation above $F_{IN\text{ max}}$	21
Figure 5-9	Overload Protection	22
Figure 5-10	Diagnostic Block Diagram	23
Figure 5-11	Current Sense for Nominal and Overload Condition	24
Figure 5-12	I_{IL0} and I_{ISO} definition	25
Figure 5-13	Improved Current Sense Accuracy after 2-Point Calibration	26
Figure 5-14	Fault Acknowledgement	27
Figure 7-1	Application Diagram with BTS50025-1TEA	40
Figure 8-1	PG-TO-252-5-11 (RoHS-Compliant)	42

Block Diagram

2 Block Diagram

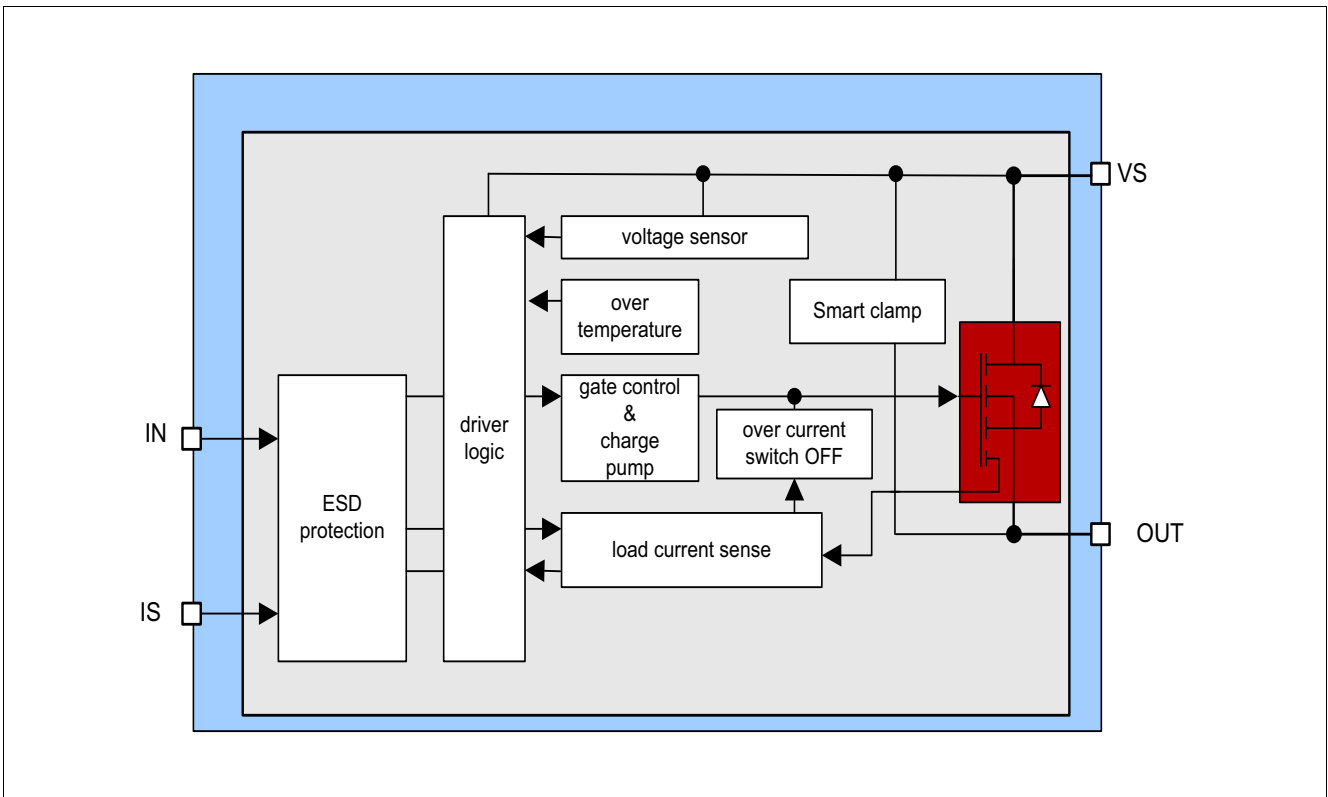

Figure 2-1 Block Diagram for the BTS50025-1TEA

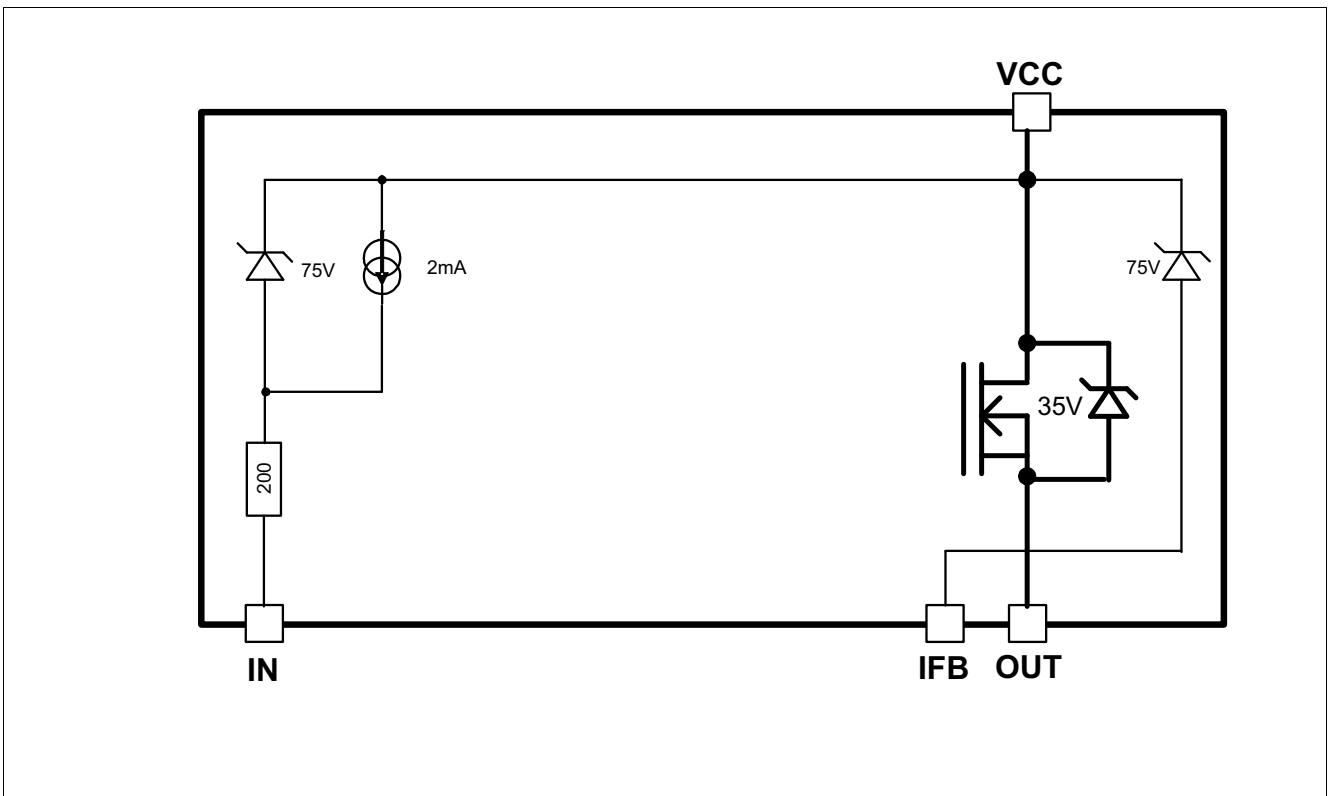

Figure 2-2 Internal diode diagram

Pin Configuration

3 Pin Configuration

3.1 Pin Assignment

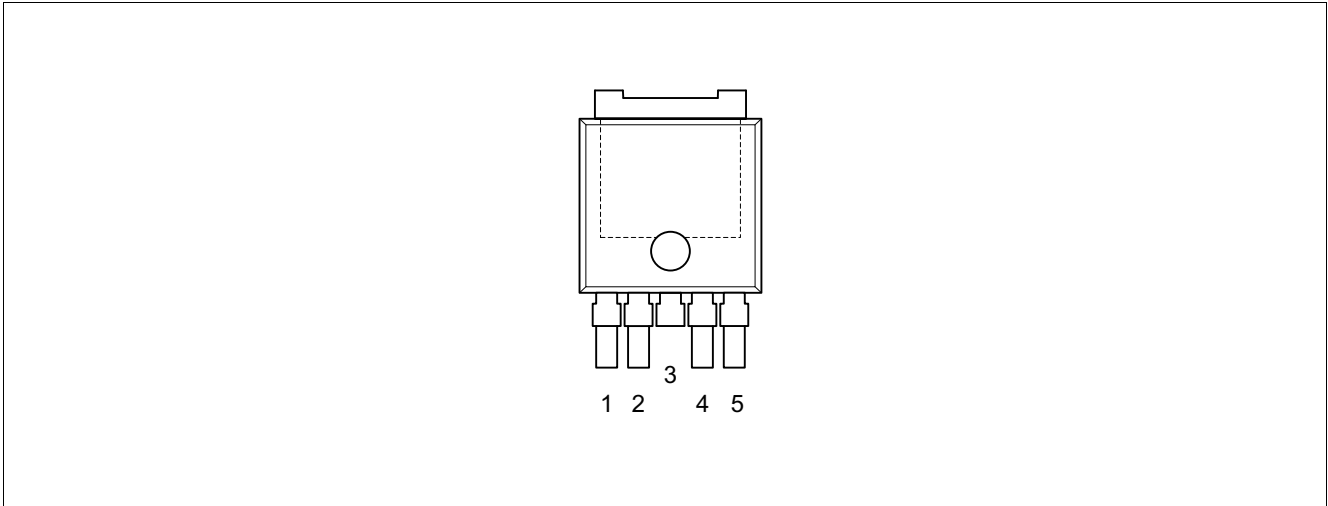

Figure 3-1 Pin Configuration

3.2 Pin Definitions and Functions

Pin	Symbol	Function
1	OUT	OUTput; Protected high side power output channel ¹⁾
2	IN	INput ; Digital signal to switch ON channel with Bipolar or Mosfet (active “low”)
3, Cooling tab	VS	Supply Voltage ; Battery voltage
4	IS	Sense; Analog/Digital signal for diagnosis, if not used: left open
5	OUT	OUTput; Protected high side power output channel ¹⁾

1) All output pins are internally connected and they also have to be connected together on the PCB. Not shorting all outputs on PCB will considerably increase the ON-state resistance and decrease the current sense / overcurrent tripping accuracy. PCB traces have to be designed to withstand the maximum current. Exact path resistance matching on both outputs to common point is needed also for short circuit robustness and reliability at high current.

Pin Configuration

3.3 Voltage and Current Definition

Figure 3-2 shows all terms used in this data sheet, with associated convention for positive values.

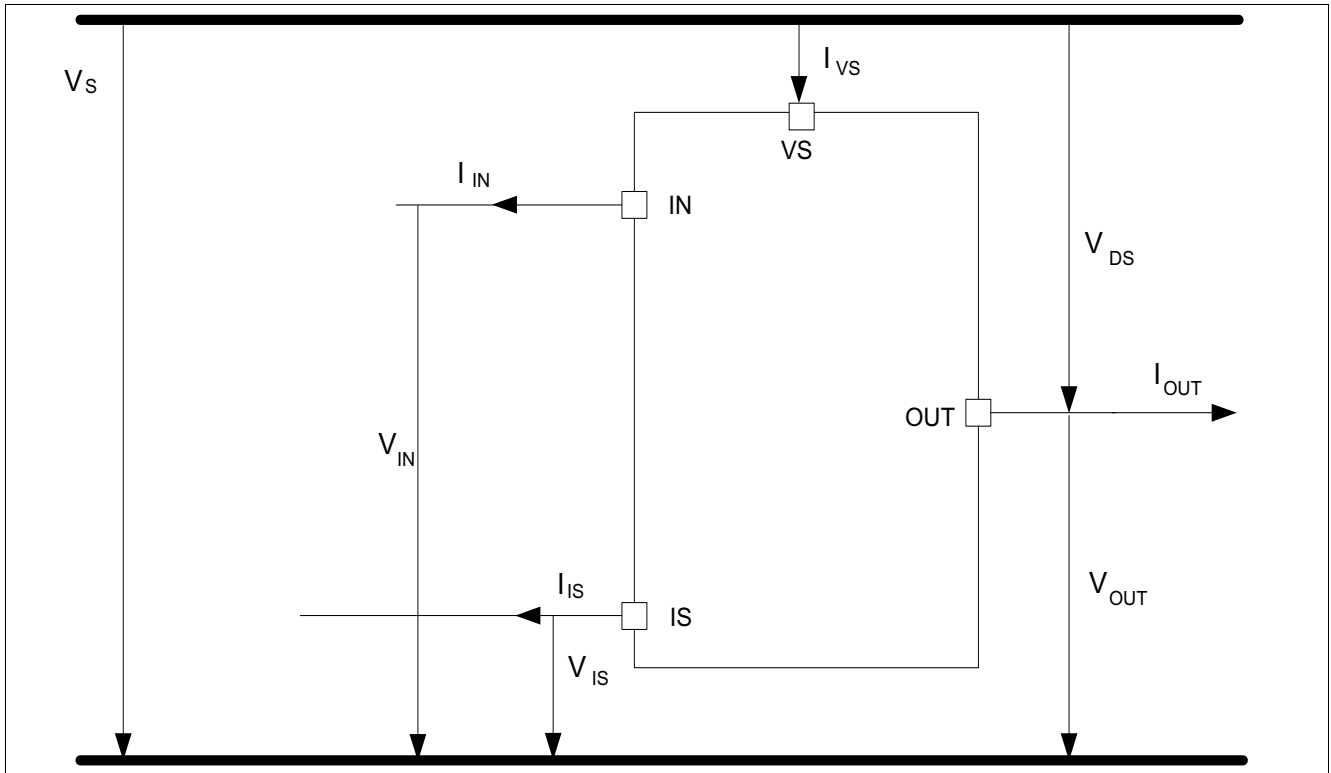

Figure 3-2 Voltage and Current Definition

General Product Characteristics

4 General Product Characteristics

4.1 Absolute Maximum Ratings

Table 2 Absolute Maximum Ratings¹⁾

$T_j = -40^\circ\text{C}$ to $+150^\circ\text{C}$; (unless otherwise specified)

Parameter	Symbol	Values			Unit	Note or Test Condition	Number
		Min.	Typ.	Max.			
Supply Voltages							
Supply Voltage	V_S	-0.3	-	35	V	-	P_4.1.1
Reverse Polarity Voltage	$-V_{S(\text{REV})}$	0	-	18	V	²⁾ $V_{\text{in}}=0$ V $T_A = 25^\circ\text{C}$ $R_L \geq 0.68 \Omega$ $t < 5$ min.	P_4.1.2
Load Dump Voltage	$V_{S(\text{LD})}$	-	-	45	V	Suppressed Load Dump acc. to ISO16750-2 $R_1 = 2 \Omega$ $t_d=200$ ms $U_S=100$ V $R_L = 0.68 \Omega$ $R_{IS} = 1$ k Ω $V_{S(\text{LD})} = U_S^*$	P_4.1.3
Short Circuit Capability							
Supply Voltage for Short Circuit Protection	$V_{S(\text{SC})}$	3.1	-	27	V	In accordance to AEC Q100-012, Figure-1 Test Circuit.	P_4.1.4
Input Pin							
Voltage at IN pin	$V_S - V_{\text{in}}$	-16	-	75	V	-	P_4.1.6
Current through IN pin	I_{IN}	-50	-	50	mA	-	P_4.1.20
Maximum Input Frequency	F_{in}	-	-	200	Hz	$5.8\text{V} < V_S - V_{\text{IN}} < 27\text{V}$	P_4.1.7
Maximum Retry Cycle Rate in Fault Condition	F_{fault}	-	-	200	Hz	-	P_4.1.8

General Product Characteristics

Table 2 Absolute Maximum Ratings¹⁾ (cont'd)

$T_j = -40^\circ\text{C}$ to $+150^\circ\text{C}$; (unless otherwise specified)

Parameter	Symbol	Values			Unit	Note or Test Condition	Number
		Min.	Typ.	Max.			
Sense Pin							
Voltage at IS pin	$V_S - V_{IS}$	-0.3	-	75	V	-	P_4.1.9
Current through IS Pin	I_{IS}	-50	-	50	mA	-	P_4.1.10
Power Stage							
Maximum Energy Dissipation by Switching Off Inductive Load Single Pulse over Lifetime	E_{AS}	-	-	600	mJ	$V_S = 13.5\text{ V}$ $I_L = 19\text{ A}$ $T_{J(0)} \leq 150^\circ\text{C}$ See Figure 1	P_4.1.11
Maximum Energy Dissipation Repetitive Pulse	E_{AR}	-	-	130	mJ	³⁾ $V_S = 13.5\text{ V}$ $I_L = 19\text{ A}$ $T_{J(0)} \leq 105^\circ\text{C}$ See Figure 1	P_4.1.12
Maximum Energy Dissipation Repetitive Pulse	E_{AR}	-	-	80	mJ	³⁾ $V_S = 13.5\text{ V}$ $I_L = 40\text{ A}$ $T_{J(0)} \leq 105^\circ\text{C}$ See Figure 1	P_4.1.13
Voltage at OUT Pin	$V_S - V_{OUT}$	-0.3	-	35	V	-	P_4.1.14
Temperatures							
Junction Temperature	T_J	-40	-	150	$^\circ\text{C}$	-	P_4.1.15
Dynamic Temperature Increase while Switching	ΔT_J	-	-	60	K	-	P_4.1.16
Storage Temperature	T_{STG}	-55	-	150	$^\circ\text{C}$	-	P_4.1.17
ESD Susceptibility							
ESD Susceptibility (all Pins)	$V_{ESD(HBM)}$	-2	-	2	kV	HBM ⁴⁾	P_4.1.18
ESD Susceptibility OUT Pin vs. V_S	$V_{ESD(HBM)}$	-4	-	4	kV	HBM ⁴⁾	P_4.1.19
ESD Susceptibility (all Pins)	$V_{ESD(CDM)}$	-500	-	500	V	CDM ⁵⁾	P_4.1.21
ESD Susceptibility (corner Pins)	$V_{ESD(CD)}$	-750	-	750	V	CDM ⁵⁾	P_4.1.22

1) Not subject to production test, specified by design.

2) The device is mounted on a FR4 2s2p board according to Jedec JESD51-2,-5,-7 at natural convection.

3) Setup with repetitive EAR and superimposed TC conditions (like AEC-Q100-PTC, $\leq 10^6$ pulses with $E \leq E_{AR}$, $\leq 10^3$ passive temperature cycles), parameter drift within datasheet limits possible

4) ESD susceptibility, Human Body Model "HBM" according to AEC Q100-002.

5) ESD susceptibility, Charged Device Model "CDM" according to AEC Q100-011.

Notes

1. Stresses above the ones listed here may cause permanent damage to the device. Exposure to absolute maximum rating conditions for extended periods may affect device reliability.
2. Integrated protection functions are designed to prevent IC destruction under fault conditions described in the data sheet. Fault conditions are considered as "outside" normal operating range. Protection functions are not designed for continuous repetitive operation.

General Product Characteristics

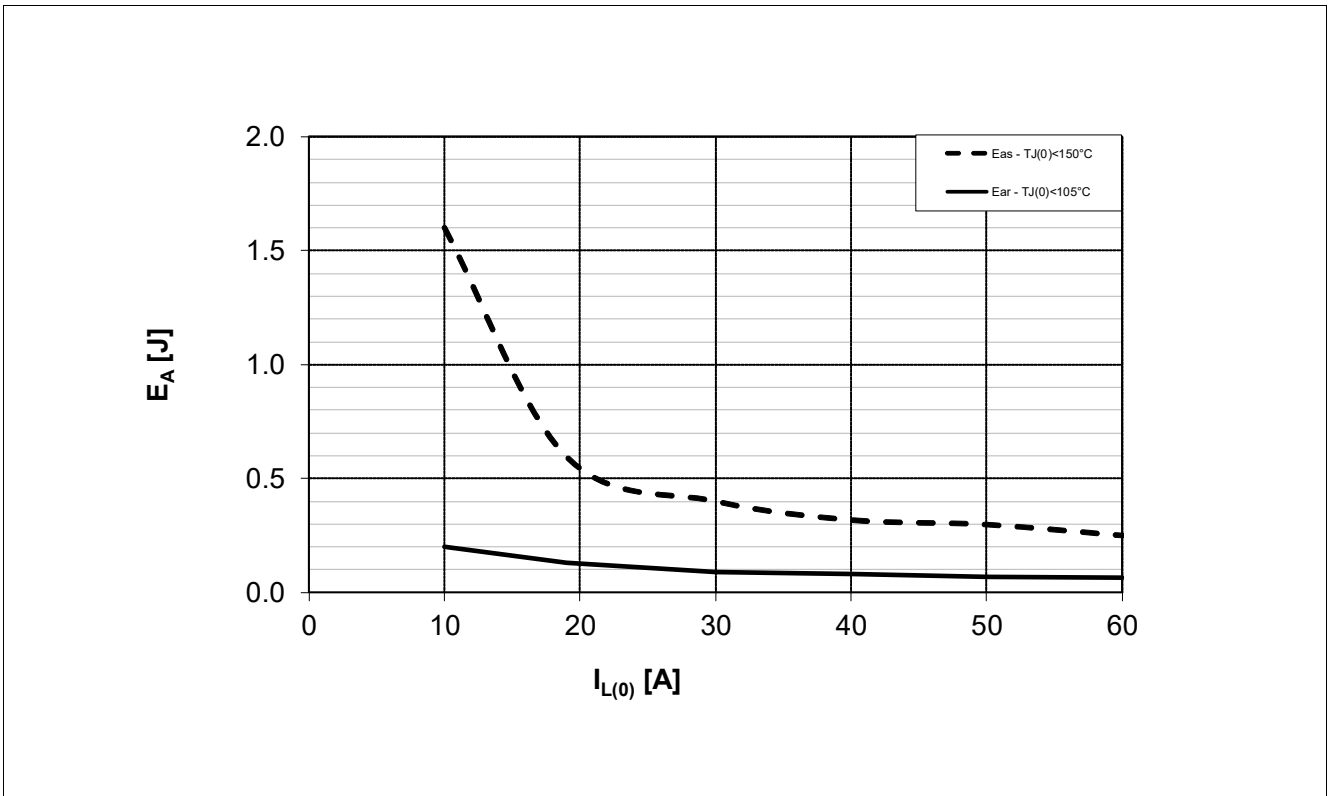

Figure 1 Maximum Energy Dissipation for Inductive Switch OFF, $E_{AS/AR}$ vs. I_L at $V_S = 13.5\text{ V}$

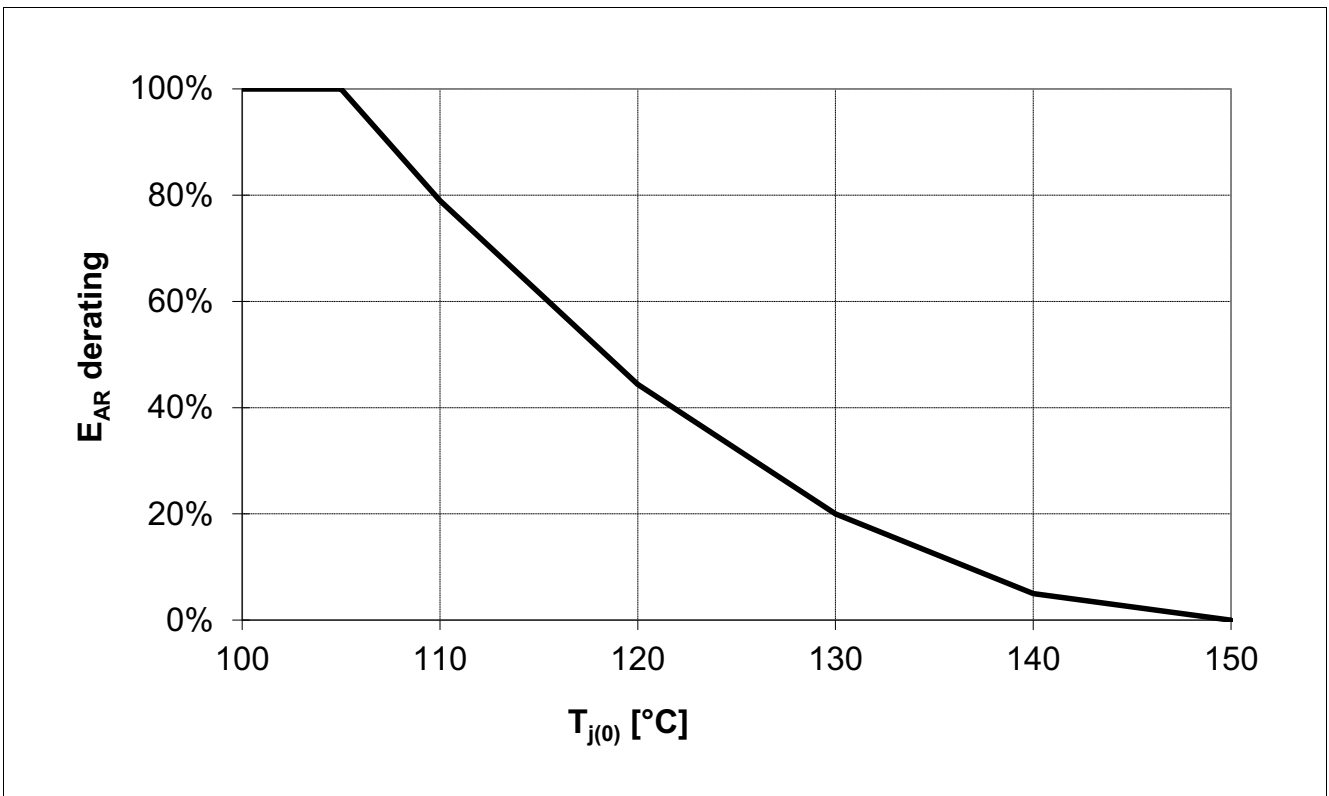

Figure 2 Maximum Energy Dissipation Repetitive Pulse temperature derating

General Product Characteristics

4.2 Functional Range

Table 3 Functional Range

Parameter	Symbol	Values			Unit	Note or Test Condition	Number
		Min.	Typ.	Max.			
Supply Voltage Range for Nominal Operation	$V_{S(NOM)}$	5.8	–	18	V	–	P_4.2.1
Supply Voltage Range for Extended Operation	$V_{S(EXT)}$	3.1	–	27	V	¹⁾ Parameter deviation possible	P_4.2.2

1) Protection functions still operative

Note: Within the functional or operating range, the IC operates as described in the circuit description. The electrical characteristics are specified within the conditions given in the Electrical Characteristics table.

General Product Characteristics

4.3 Thermal Resistance

Note: This thermal data was generated in accordance with JEDEC JESD51 standards. For more information, go to www.jedec.org.

Table 4 Thermal Resistance

Parameter	Symbol	Values			Unit	Note or Test Condition	Number
		Min.	Typ.	Max.			
Junction to Case	R_{thJC}	–	–	0.8	K/W	1)	P_4.3.1
Junction to Ambient	$R_{thJA(2s2p)}$	–	22	–	K/W	1)2)	P_4.3.2
Junction to Ambient	$R_{thJA(1s0p/600\text{mm}^2)}$	–	35	–	K/W	1)3)	P_4.3.3

- 1) Not subject to production test, specified by design.
- 2) Specified R_{thJA} value is according to Jedec JESD51-2,-5,-7 at natural convection on FR4 2s2p board; The Product (Chip+Package) was simulated on a 76.2 × 114.3 × 1.5 mm board with 2 inner copper layers (2 × 70 μm Cu, 2 × 35 μm Cu). Where applicable a thermal via array under the exposed pad contacted the first inner copper layer. $T_A = 25^\circ\text{C}$. Device is dissipating 2 W power.
- 3) Specified R_{thJA} value is according to Jedec JESD51-2,-5,-7 at natural convection on FR4 1s0p board; the Product (Chip+Package) was simulated on a 76.2 × 114.3 × 1.5 mm board with only one top copper layer 1 × 70 μm. $T_A = 25^\circ\text{C}$. Device is dissipating 2 W power.

Figure 3 is showing the typical thermal impedance of BTS50025-1TEA mounted according to JEDEC JESD51-2,-5,-7 at natural convection on FR4 1s0p and 2s2p boards.

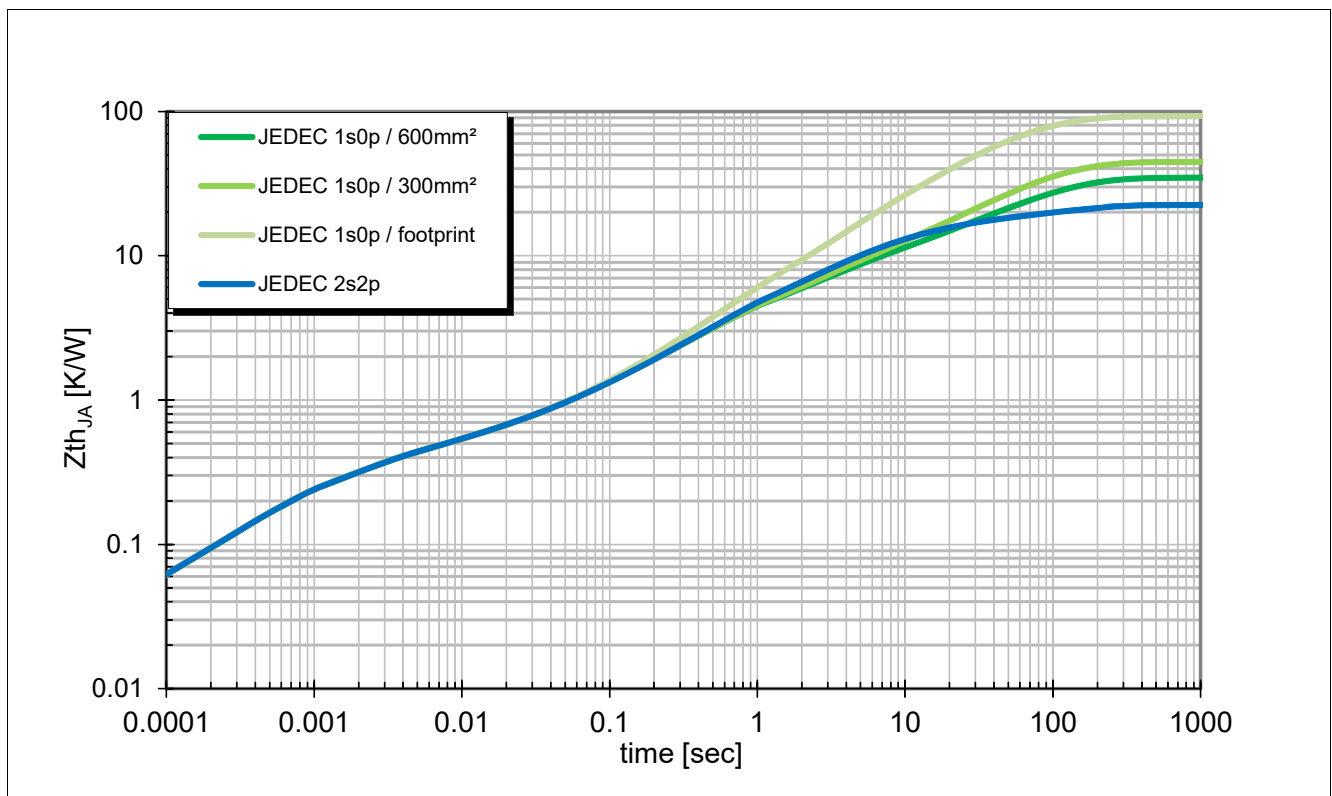

Figure 3 Typical Transient Thermal Impedance $Z_{th(JA)} = f(\text{time})$ for Different PCB Conditions

Functional Description

5 Functional Description

5.1 Power Stage

The power stage is built by a N-channel power MOSFET (DMOS) with a charge pump.

5.1.1 Output ON-State Resistance

The ON-state resistance $R_{DS(ON)}$ depends on the supply voltage as well as the junction temperature T_J . **Page 35** shows the dependencies in terms of temperature and supply voltage, for the typical ON-state resistance. The behavior in reverse polarity is described in **Chapter 5.2.1**.

A LOW signal (see **Chapter 5.1.2**) at the input pin causes the power DMOS to switch ON with a dedicated slope, which is optimized in terms of EMC emission.

5.1.2 Switching Resistive Loads

Figure 5-1 shows the typical timing when switching a resistive load. The power stage has a defined switching behavior. Defined slew rates results in lowest EMC emission at minimum switching losses.

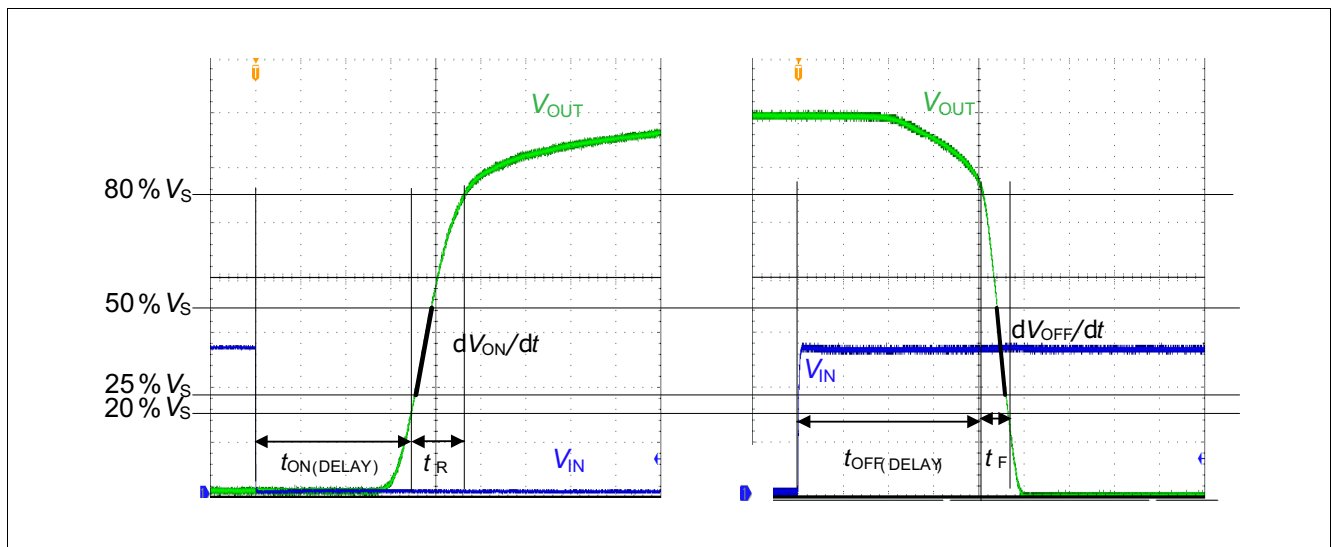

Figure 5-1 Switching a Resistive Load: Timing

5.1.3 Switching Inductive Loads

5.1.3.1 Output Clamping

When switching OFF inductive loads with high side switches, the voltage V_{OUT} drops below ground potential, because the inductance intends to continue driving the current. To prevent the destruction of the device due to high voltages, there is a Infineon® SMART CLAMPING mechanism implemented that keeps negative output voltage to a certain level ($V_S - V_{DS(CL)}$). Please refer to **Figure 5-2** and **Figure 5-3** for details. Nevertheless, the maximum allowed load inductance remains limited.

Functional Description

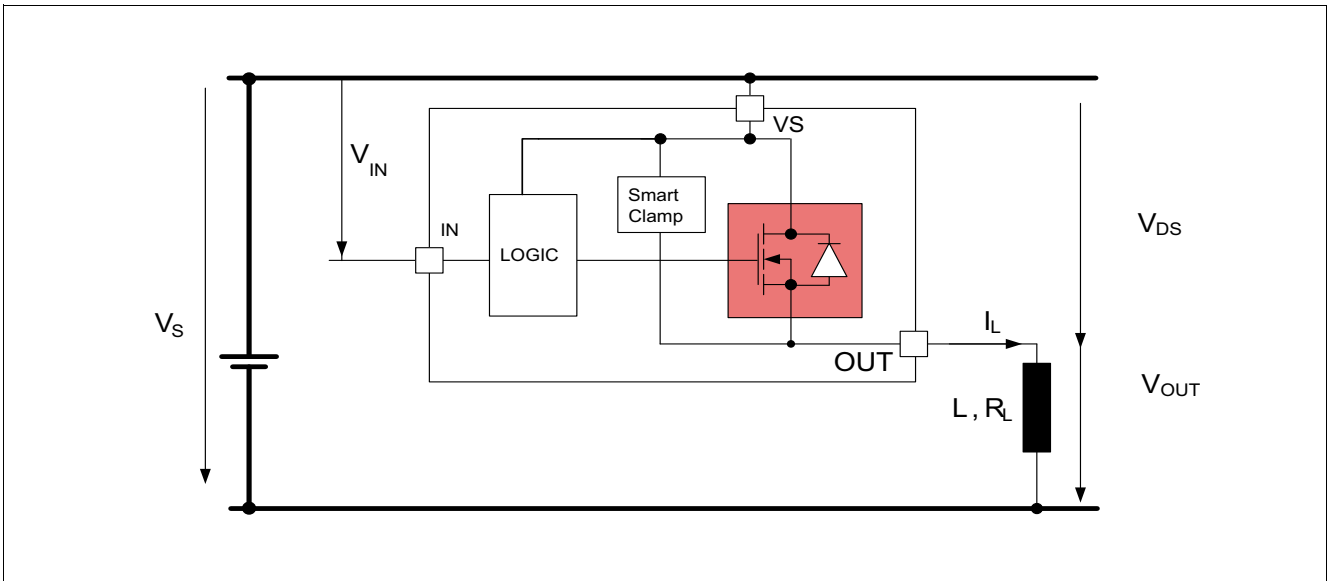

Figure 5-2 Output Clamp

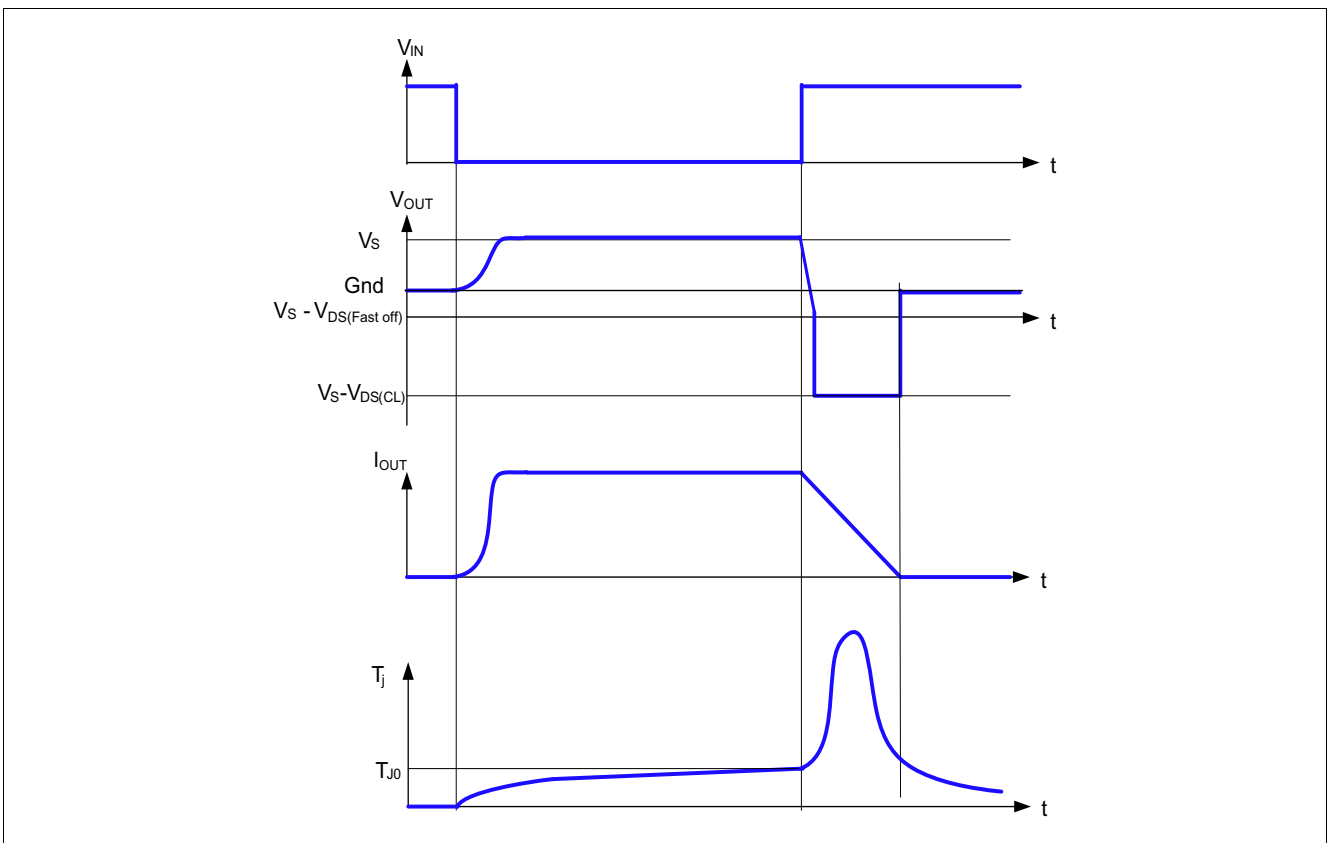

Figure 5-3 Switching an Inductance

The BTS50025-1TEA provides Infineon® SMART CLAMPING functionality. To increase the energy capability, the clamp voltage $V_{DS(CL)}$ increases with junction temperature T_j and with load current I_L . Refer to [Page 37](#).

Functional Description

5.1.3.2 Maximum Load Inductance

During demagnetization of inductive loads, energy must be dissipated in the BTS50025-1TEA. This energy can be calculated with following equation:

$$E = V_{DS(CL)} \times \frac{L}{R_L} \times \left[\frac{V_S - V_{DS(CL)}}{R_L} \times \ln \left(1 - \frac{R_L \times I_L}{V_S - V_{DS(CL)}} \right) + I_L \right] \quad (5.1)$$

Following equation simplifies under the assumption of $R_L = 0 \Omega$.

$$E = \frac{1}{2} \times L \times I_L^2 \times \left(1 - \frac{V_S}{V_S - V_{DS(CL)}} \right) \quad (5.2)$$

The energy, which is converted into heat, is limited by the thermal design of the component. See [Figure 1](#) for the maximum allowed energy dissipation as function of the load current.

Functional Description

5.1.4 PWM Switching

The switching losses during this operation should be properly considered (see following equation):

$$P_{TOTAL} = (\text{switching_ON_energy} + \text{switching_OFF_energy} + I_L^2 \times R_{DS(ON)} \times t_{DC}) / \text{period}$$

In the event of a fault condition it has to be ensured, that the PWM frequency will not exceed a maximum retry frequency of f_{FAULT} (parameter P_4.1.9). With this measure the short circuit robustness n_{RSC1} (parameter P_4.1.4) can be utilized. Operation at nominal PWM frequency can only be restored, once the fault condition is overcome.

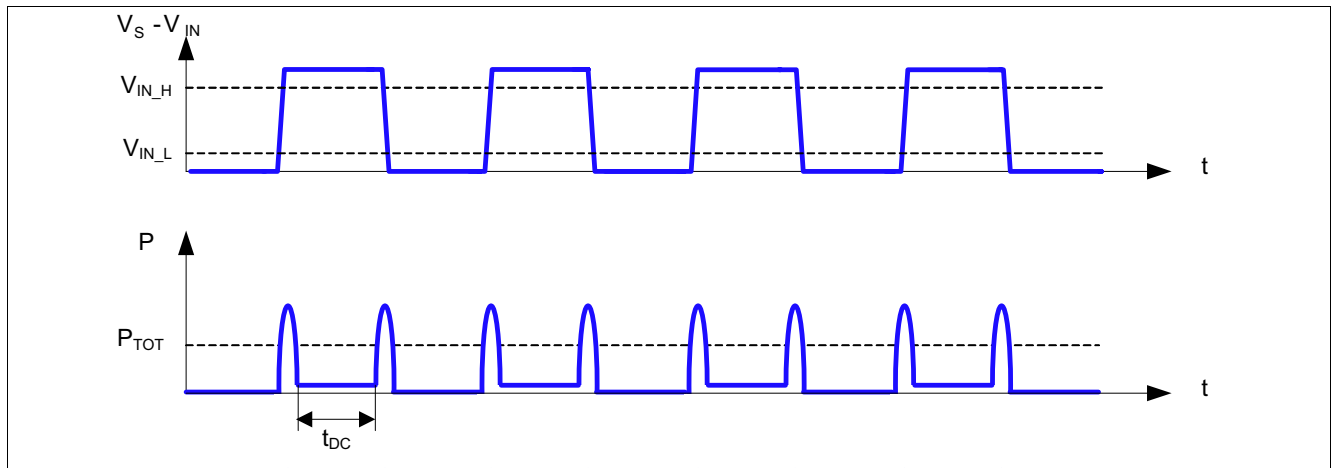

Figure 5-4 Switching in PWM

5.1.5 Advanced switch-off behavior

In order to reduce device stress when switching OFF Inductive and critical loads, the device provides an advanced switch off functionality which results in a faster switch off behavior. This fast switch off functionality is triggered by one the following conditions:

- The device is commanded off by applying $V_{IN(L)}$ at the IN pin. During the switch OFF operation the OUT pins' voltage in respect to VS pin drops below $V_{ds(\text{fast off})}$. See [Figure 5-3](#).
- The device is commanded on or is already in on-state. The device then detects a short circuit condition ($I_L \geq I_{CL(0)}$) and initiates a protective switch off. Please refer to [Chapter 5.3.1.1](#) and [Chapter 5.3.1.2](#) for details.
- The device is commanded on or is already in on-state. The device then detects an over-temperature condition.

Functional Description

5.2 Input Pins

5.2.1 Input Circuitry

The input circuitry is referenced to V_S . To turn on the device $V_S - V_{IN}$ must be higher than $V_{IN(H)}$ and lower than $V_{IN(L)}$ to turn off the device. The most common way is to use a bipolar transistor to connect the input pin to the ground. When the device is latched in protection mode $V_S - V_{IN}$ must be lower than $V_{IN(L)}$ and I_{in} lower than $I_{IN(L)}$ in order to reset the latch. The device provides Infineon® ReverSave™ functionality which turns on the power mosfet in reverse polarity. This functionality required to have a diode in parallel of the bipolar transistor. **Figure 5-5** shows the electrical equivalent input circuitry.

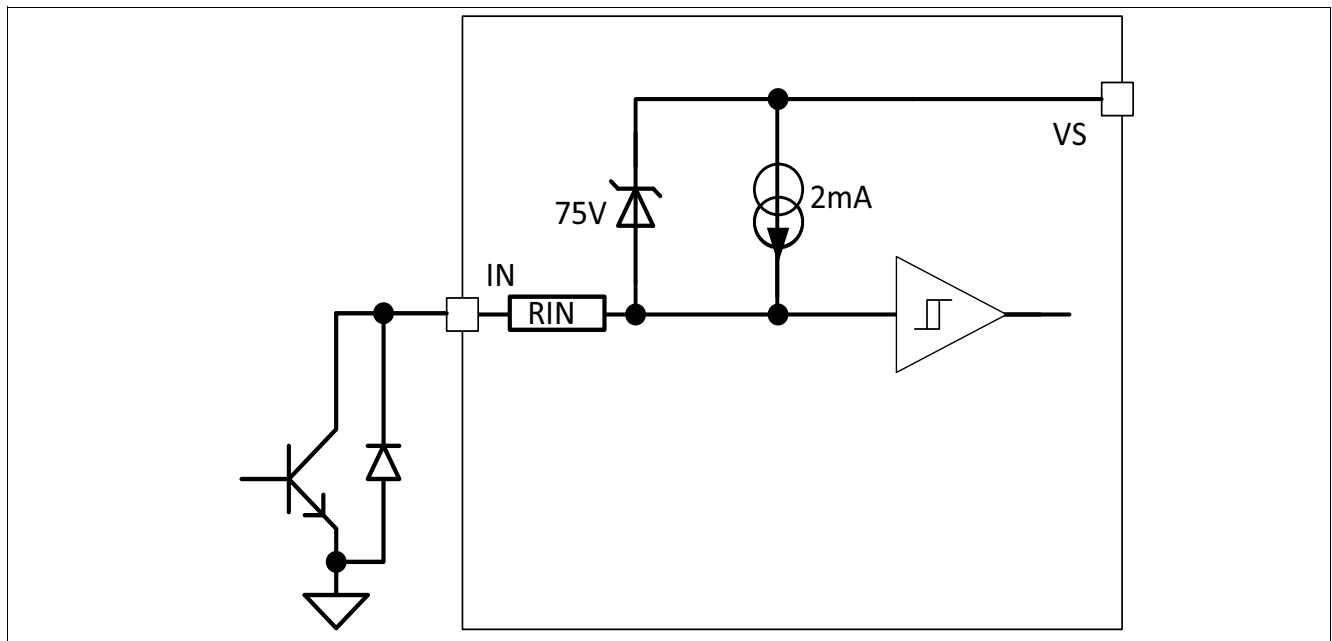

Figure 5-5 Input Pin Circuitry

5.3 Protection Functions

The device provides embedded protective functions. Integrated protection functions are designed to prevent the destruction of the IC from fault conditions described in the data sheet. Fault conditions are considered as “outside” normal operating range. Protection functions are designed neither for continuous nor for repetitive operation.

Figure 5-6 describes the typical functionality of the diagnosis and protection block.

Functional Description

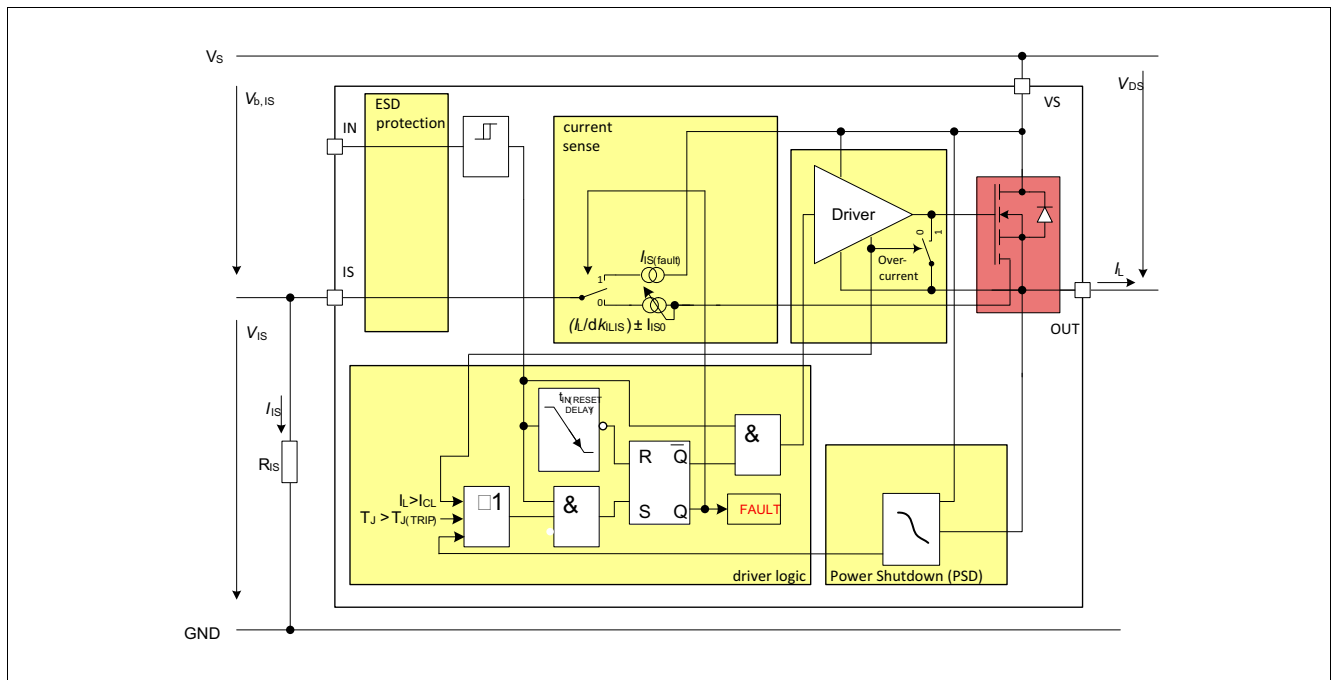

Figure 5-6 Diagram of Diagnosis & Protection Block

5.3.1 Overload Protection

In case of overload, high inrush current or short circuit to ground, the BTS50025-1TEA offers several protection mechanisms. Any protective switch OFF latches the output. To restart the device, it is necessary to set $V_s - V_{in} < V_{in(l)}$ and I_{in} lower than $I_{IN(L)}$ for $t > t_{IN(RESETDELAY)}$. This is a latch behavior. [Figure 5-9](#) gives a sketch of the situation.

5.3.1.1 Activation of the Switch into Short Circuit (Short Circuit Type 1)

When the switch is activated into short circuit, the current will raise. When the output current reaches $I_{CL(0)}$ value, the device is latched and will turn off after $t_{OFF(TRIP)}$ regardless the output current value. For overload (short circuit or overtemperature), the maximum retry cycle (f_{fault}) under fault condition must be considered.

5.3.1.2 Short Circuit Appearance when the Device is already ON (Short Circuit Type 2)

When the device is in ON state and a short circuit to ground appears at the output (SC2) with an overcurrent higher than $I_{CL(0)}$, the device automatically turns OFF and latches the device.

5.3.1.3 Over-power shutdown (PSD)

The BTS50025-1TEA integrates an over-power shutdown protection in order to limit the power dissipation. This protection intends to limit the maximum junction temperature in case of soft short circuit ($IL < I_{CL(0)}$), repetitive short circuit or short circuit at low voltage.

In case of a short circuit at low voltage with high resistor or inductor in the battery line, V_s can drop below $V_{VS-VIN(PSD)}$ and the load current will not reach the $I_{CL(0)}$. In such condition the over-power shutdown protection will be activated and will latch the device after $t_{PSD(UV)}$.

Functional Description

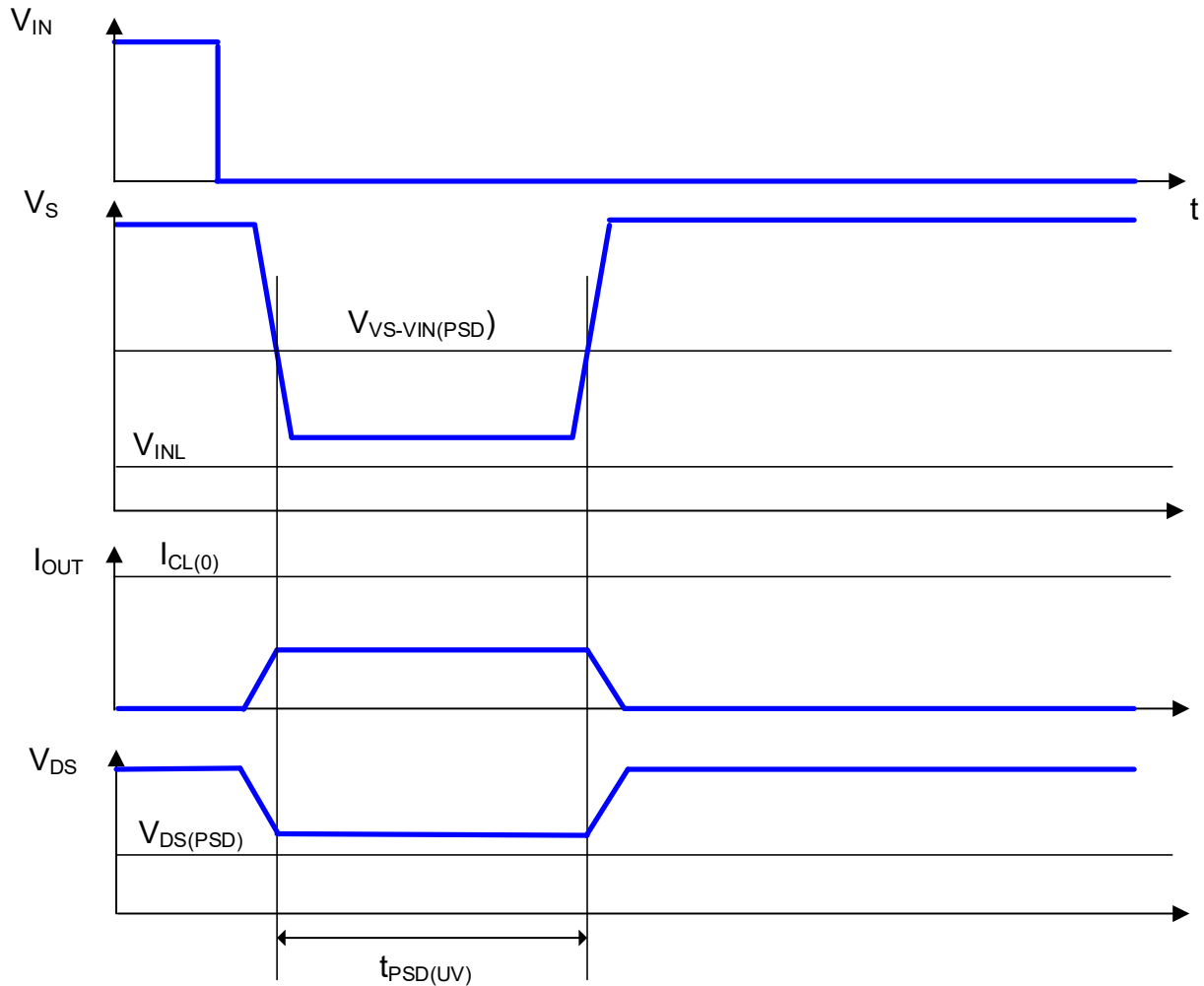

Figure 5-7 Over Power Shutdown behavior at low voltage

It also limits the maximum PWM frequency below F_{IN} . See [Figure 5-8](#)

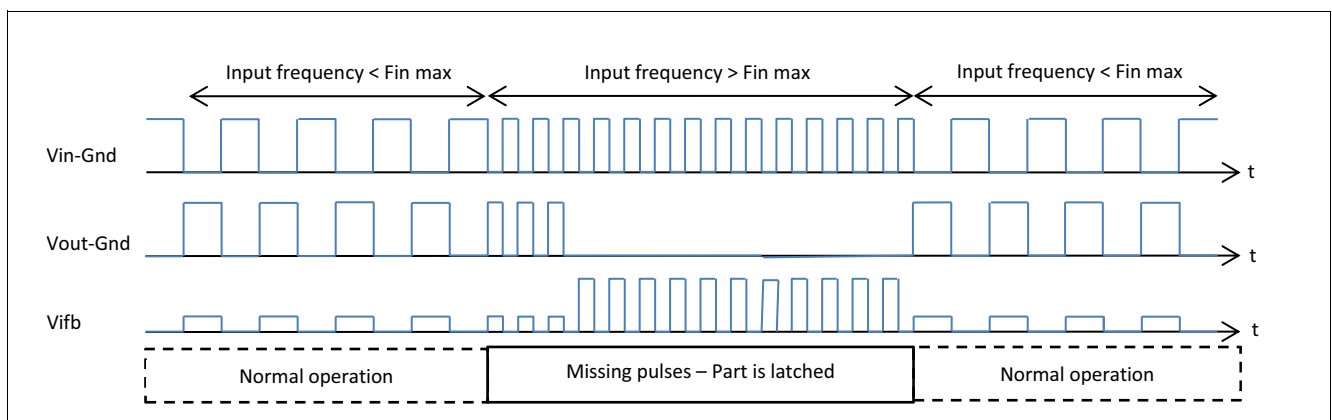

Figure 5-8 Behavior of the BTS50025-1TEA during PWM operation above F_{IN} max

5.3.2 Temperature Limitation in the Power DMOS

The BTS50025-1TEA incorporates a temperature sensor. Triggering the over-temperature ($T_{J(TRIP)}$) will switch OFF the Power Mosfet to prevent destruction and latches the device.

Functional Description

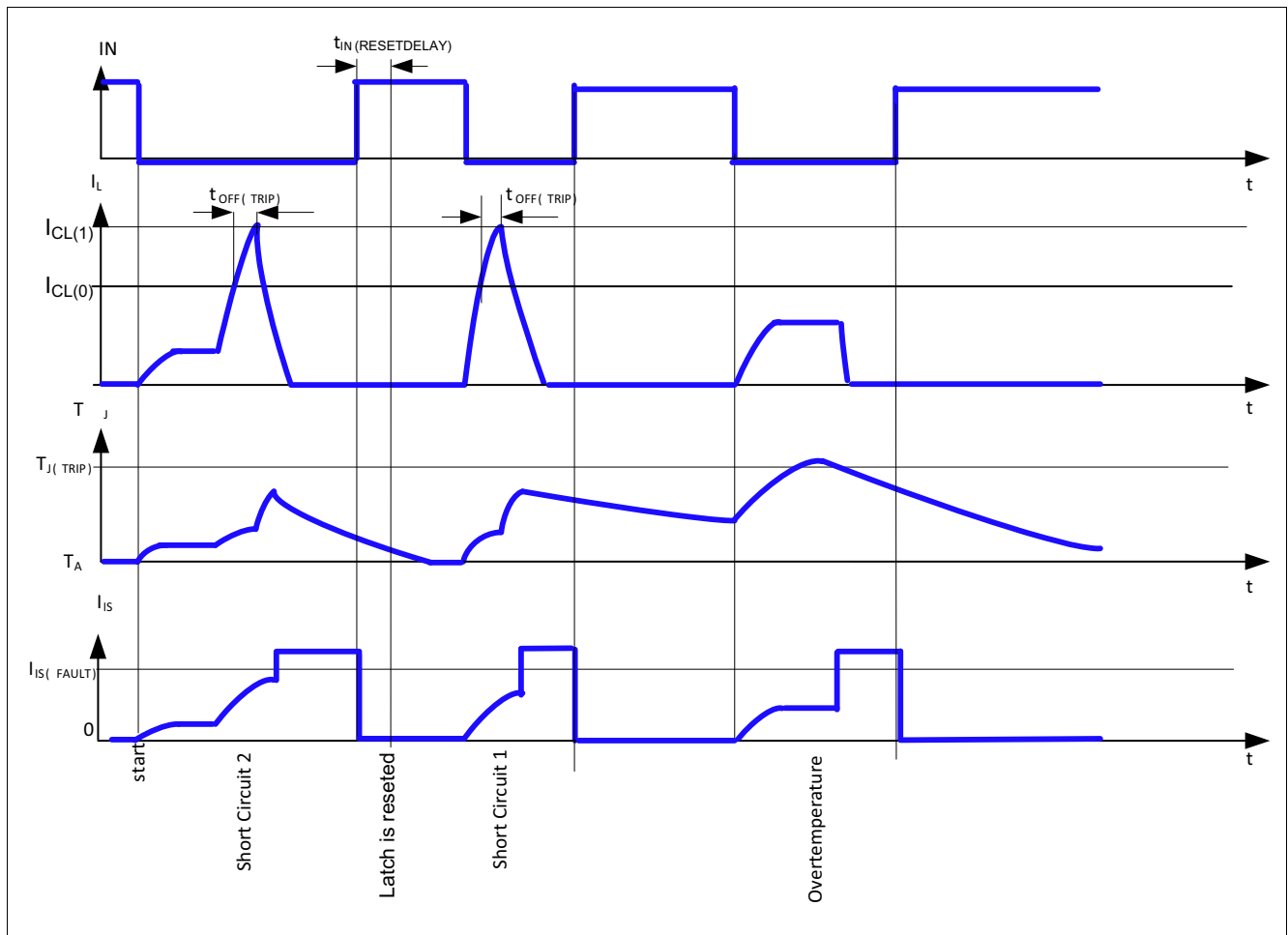

Figure 5-9 Overload Protection

The current sense exact signal timing can be found in the [Chapter 5.4.3.2](#). It is represented here only for device’s behavior understanding.

5.4 Diagnostic Functions

For diagnosis purposes, the BTS50025-1TEA provides a combination of digital and analog signal at pin IS.

5.4.1 IS Pin

The BTS50025-1TEA provides an enhanced current sense signal called I_{IS} at pin IS. As long as no “hard” failure mode occurs (short circuit to GND / overcurrent / overtemperature) and the condition $V_{IS} \leq V_{OUT} - 3.5\text{ V}$ is fulfilled, a proportional signal to the load current is provided. The complete IS pin and diagnostic mechanism is described in [Figure 5-10](#). The accuracy of the sense current depends on temperature and load current. In case of failure, a fixed $I_{IS(FAULT)}$ is provided. In order to get the fault current in the specified range, the condition $V_S - V_{IS} \geq 3.5\text{ V}$ must be fulfilled.

Functional Description

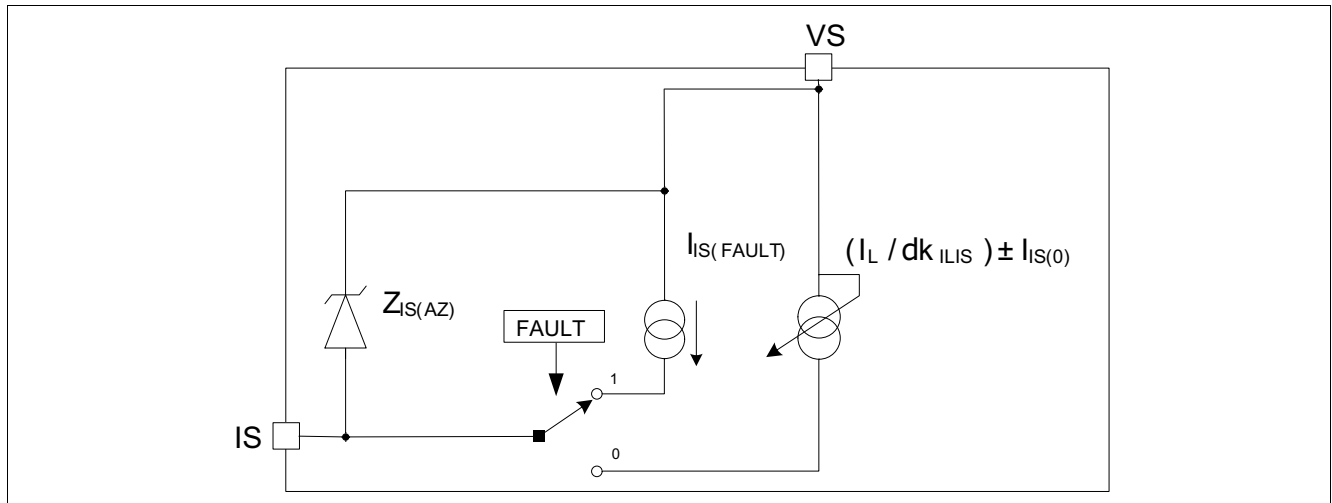

Figure 5-10 Diagnostic Block Diagram

5.4.2 SENSE Signal in Different Operation Modes

Table 5-1 Sense Signal, Function of Operation Mode¹⁾

Operation mode	Input Level	Output Level V_{OUT}	Diagnostic Output (IS) ²⁾
Normal operation	HIGH (OFF)	GND	$I_{IS(OFF)}$
Short circuit to GND		GND	$I_{IS(OFF)}$
Overtemperature		GND	$I_{IS(OFF)}$
Short circuit to VS		V_S	$I_{IS(OFF)}$
Open Load		Z	$I_{IS(OFF)}$
Normal operation	LOW (ON)	$\sim V_S$	$I_{IS} = (I_L / dk_{ILIS}) \pm I_{IS0}$
Short circuit to GND		GND	$I_{IS(FAULT)}$
Overtemperature (after the event)		GND	$I_{IS(FAULT)}$
Short circuit to VS		V_S	$I_{IS} < I_L / dk_{ILIS} \pm I_{IS0}$
Open Load		V_S	I_{IS0}

1) Z = High Impedance

2) See [Chapter 5.4.3](#) for Current Sense Range and Improved Current Sense Accuracy.

5.4.3 SENSE Signal in the Nominal Current Range

Figure 5-11 and **Figure 5-13** show the current sense as function of the load current in the power DMOS. Usually, a pull-down resistor R_{IS} is connected to the current sense pin IS. A typical value is 1 kΩ. The dotted curve represents the typical sense current, assuming a typical dk_{ILIS} factor value. The range between the two solid curves shows the sense accuracy range that the device is able to provide, at a defined current.

$$I_{IS} = \frac{I_L}{dk_{ILIS}} + I_{IS0} \text{ with } (I_{IS} \geq 0) \tag{5.3}$$

Functional Description

where the definition of dk_{ILIS} is:

$$dk_{ILIS} = \frac{I_{L3} - I_{L1}}{I_{IS3} - I_{IS1}} \tag{5.4}$$

the definition of I_{IS0} is:

$$I_{IS0} = I_{IS1} - \frac{I_{L1}}{dk_{ILIS}} \tag{5.5}$$

and the definition of I_{L0} is:

$$I_{L0} = I_{L1} - I_{S1} \times dk_{ILIS} \tag{5.6}$$

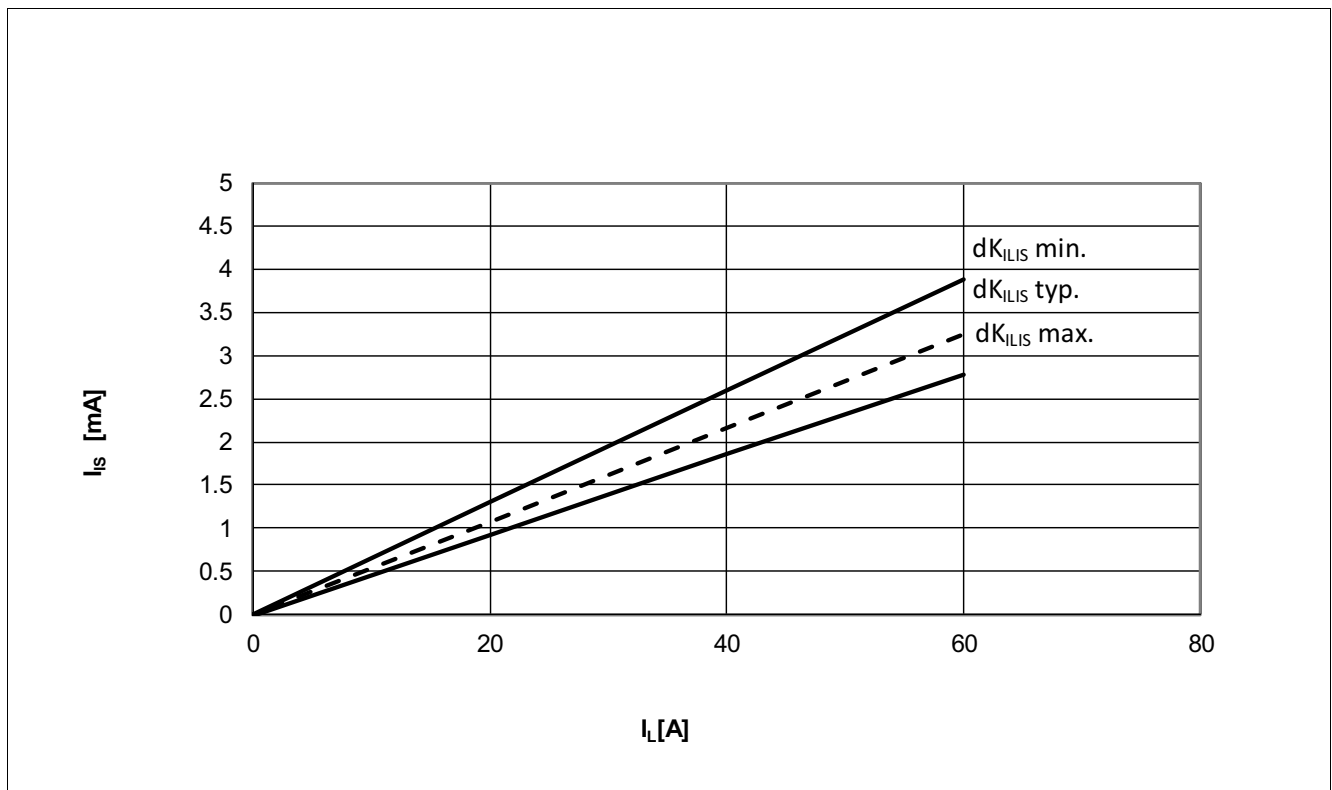

Figure 5-11 Current Sense for Nominal and Overload Condition

Functional Description

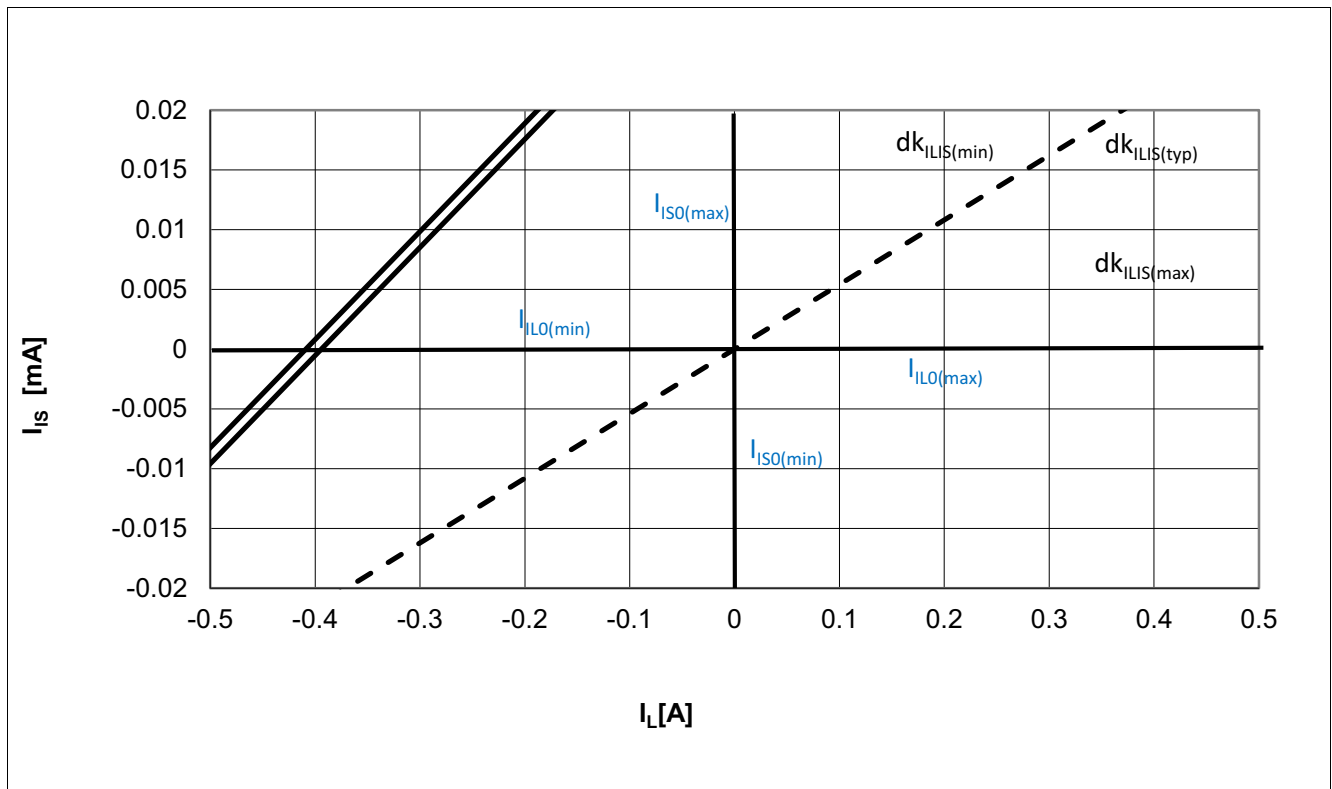

Figure 5-12 I_{IL0} and I_{ISO} definition

5.4.3.1 SENSE Signal Variation and Calibration

In some applications, an enhanced accuracy is required around the device nominal current range $I_{L(NOM)}$. To achieve this accuracy requirement, a calibration on the application is possible. After two point calibration, the BTS50025-1TEA will have a limited I_{IS} value spread at different load currents and temperature conditions. The I_{IS} variation can be described with the parameters $\Delta(dk_{ILIS(cal)})$ and the $\Delta I_{ISO(cal)}$. The blue solid line in **Figure 5-13** is the current sense ratio after the two point calibration at a given temperature. The slope of this line is defined as follows:

$$\frac{1}{dk_{ILIS(cal)}} = \frac{I_{IS(cal)2} - I_{IS(cal)1}}{I_{L(cal)2} - I_{L(cal)1}} \tag{5.7}$$

The offset is defined as follows:

$$I_{ISO(cal)} = I_{IS(cal)1} - \frac{I_{L(cal)1}}{dk_{ILIS(cal)}} = I_{IS(cal)2} - \frac{I_{L(cal)2}}{dk_{ILIS(cal)}} \tag{5.8}$$

The bluish area in **Figure 5-13** is the range where the current sense ratio can vary across temperature and load current after performing the calibration. The accuracy of the load current sensing is improved and, given a sense current value I_{IS} (measured in the application), the load current can be calculated as follow, using the absolute value for $\Delta(dk_{ILIS(cal)})$ instead of % values:

$$I_L = dk_{ILIS(cal)} \times (1 + \Delta(dk_{ILIS(cal)})) \times (I_{IS} - I_{ISO(cal)} - \Delta I_{ISO(cal)}) \tag{5.9}$$

Functional Description

where $dk_{I_{LIS(cal)}}$ is the current sense ratio measured after two-points calibration (defined in **Equation (5.7)**), $I_{ISO(cal)}$ is the current sense offset (calculated after two points calibration, see **Equation (5.8)**), and $\Delta I_{ISO(cal)}$ is the additional variation of the individual offset over life time and temperature. For a calibration at 25°C $\Delta I_{ISO(cal)}$ varies over temperature and life time for all positive $\Delta I_{ISO(cal)}$ within the differences of the temperature dependent Max. limits. All negative $\Delta I_{ISO(cal)}$ vary within the differences of the temperature dependent Min. limits.

For positive $I_{ISO(cal)}$ values ($I_{ISO(cal)} > 0$):

$$\text{Max } I_{ISO} (@T_J = 150^\circ\text{C}) - \text{Max } I_{ISO} (@T_J = 25^\circ\text{C}) \leq \Delta I_{ISO(cal)} \leq \text{Max } I_{ISO} (@T_J = -40^\circ\text{C}) - \text{Max } I_{ISO} (@T_J = 25^\circ\text{C}) \tag{5.10}$$

For negative $I_{ISO(cal)}$ values ($I_{ISO(cal)} < 0$):

$$\text{Min } I_{ISO} (@T_J = 150^\circ\text{C}) - \text{Min } I_{ISO} (@T_J = 25^\circ\text{C}) \geq \Delta I_{ISO(cal)} \geq \text{Min } I_{ISO} (@T_J = -40^\circ\text{C}) - \text{Min } I_{ISO} (@T_J = 25^\circ\text{C}) \tag{5.11}$$

Equation (5.9) actually provides four solutions for load current, considering that $\Delta(dk_{I_{LIS(cal)}}$) and $\Delta I_{ISO(cal)}$ can be both positive and negative. The load current I_L for any sense current I_{IS} will spread between a minimum I_L value resulting from the combination of lowest $\Delta(dk_{I_{LIS(cal)}}$) value and highest $\Delta I_{ISO(cal)}$ and a maximum I_L value resulting from the combination of highest $\Delta(dk_{I_{LIS(cal)}}$) value and lowest $\Delta I_{ISO(cal)}$.

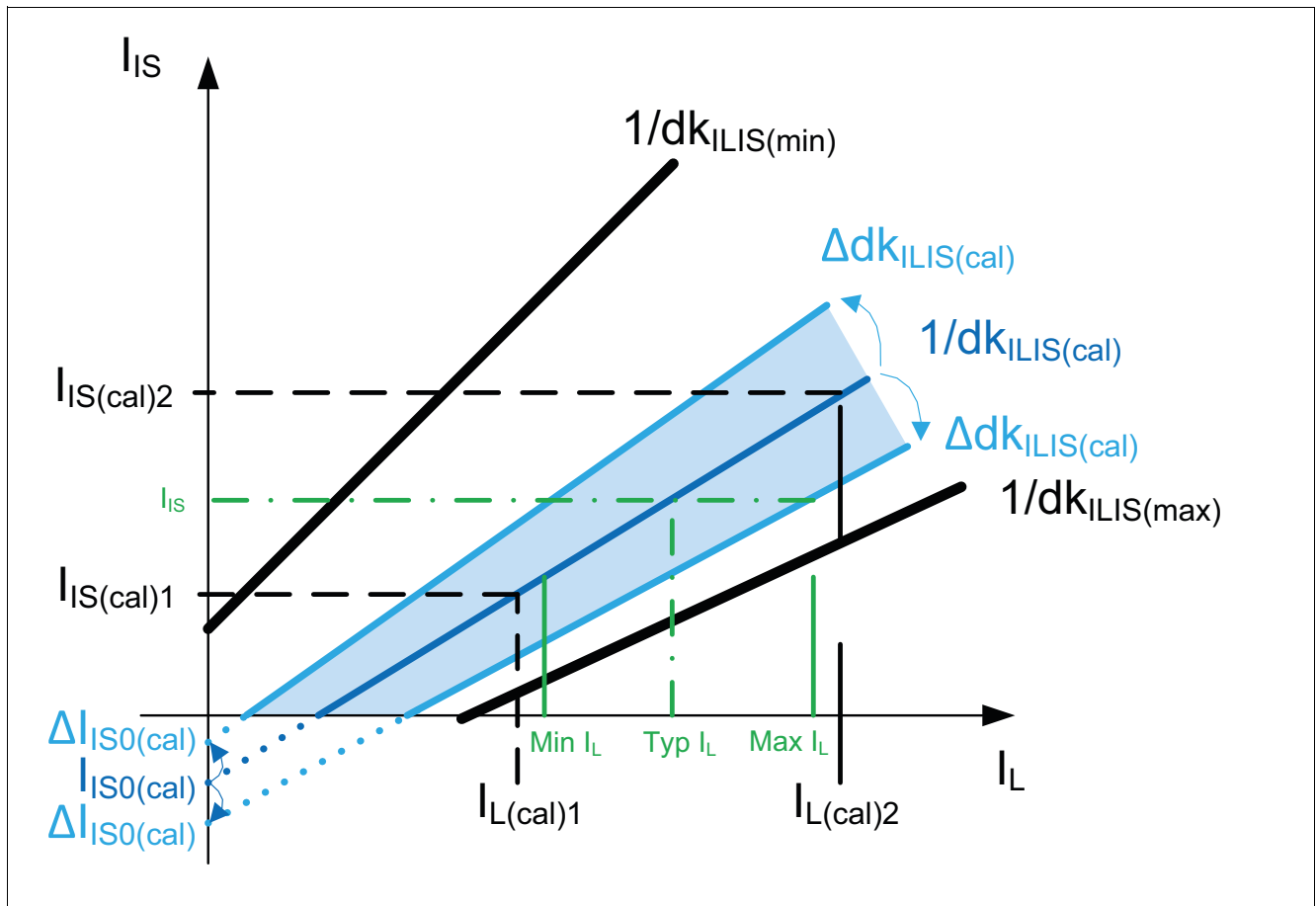

Figure 5-13 Improved Current Sense Accuracy after 2-Point Calibration

Functional Description

5.4.3.2 SENSE Signal Timing

Figure 5-14 shows the timing during settling and disabling of the sense.

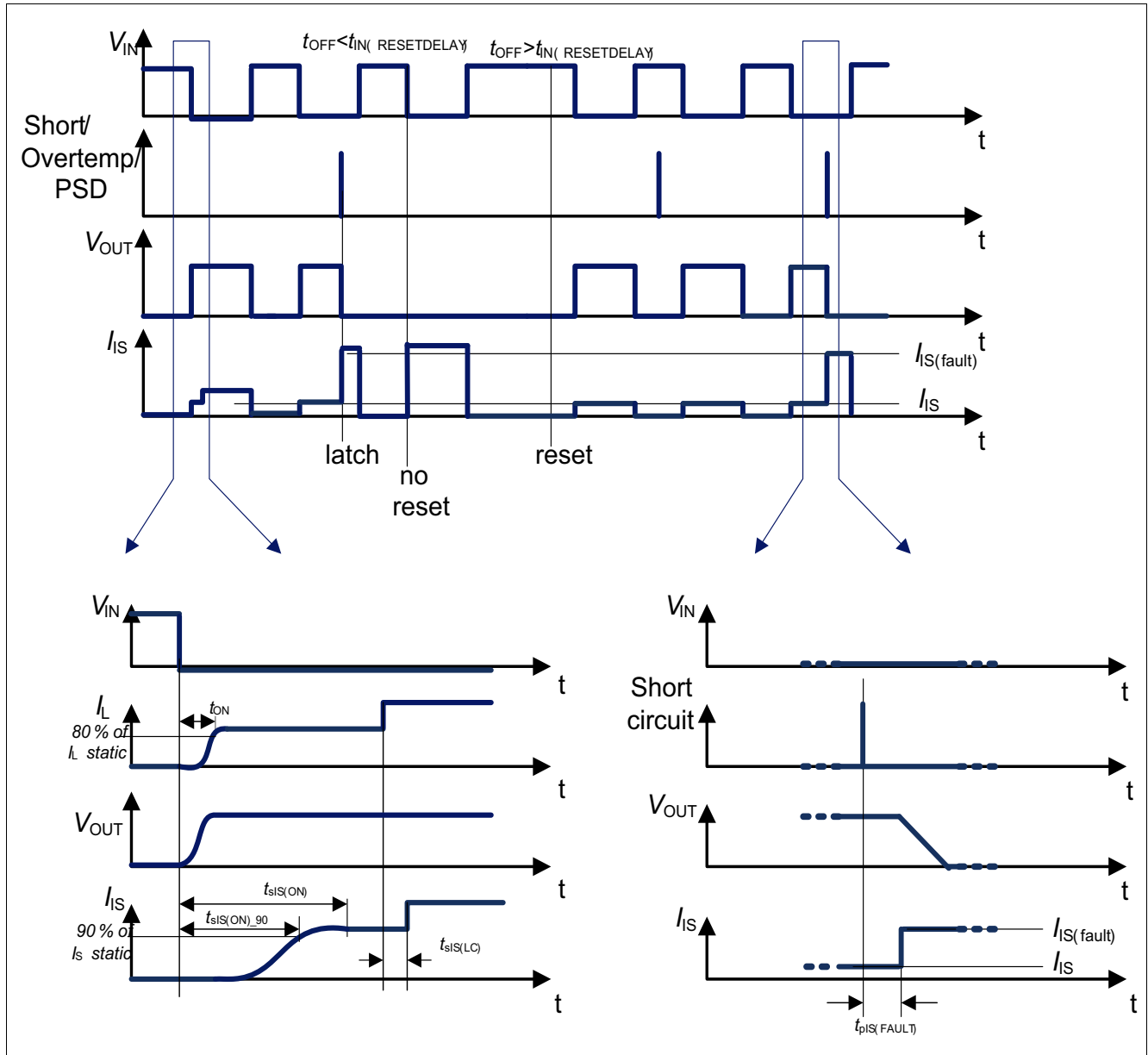

Figure 5-14 Fault Acknowledgement

5.4.3.3 SENSE Signal in Case of Short Circuit to V_S

In case of a short circuit between OUT and V_S , a major part of the load current will flow through the short circuit. As a result, a lower current compared to the nominal operation will flow through the DMOS of the BTS50025-1TEA, which can be recognized at the current sense signal.

5.4.3.4 SENSE Signal in Case of Over Load

An over load condition is defined by a current flowing out of the DMOS reaching the current over load I_{CL} or the junction temperature reaches the thermal shutdown temperature $T_{J(TRIP)}$. Please refer to **Chapter 5.3.1** for details. In that case, the SENSE signal will be $I_{IS(FAULT)}$ when the IN pin stays LOW.

Functional Description

This is a device with latch functionality. The state of the device will remain and the sense signal will remain on $I_{IS(FAULT)}$ until a reset signal comes from the IN pin. For example, when a thermal shutdown occurs, even when the over temperature condition has disappeared, the DMOS can only be reactivated when a reset signal is sent to the IN pin.

6 Electrical Characteristics BTS50025-1TEA

6.1 Electrical Characteristics Table

Table 6-1 Electrical Characteristics: BTS50025-1TEA

$V_S = 5.8 \text{ V to } 18 \text{ V}$, $T_J = -40^\circ\text{C to } +150^\circ\text{C}$ (unless otherwise specified)

For a given temperature or voltage range, typical values are specified at $V_S = 13.5 \text{ V}$, $T_J = 25^\circ\text{C}$

Parameter	Symbol	Values			Unit	Note or Test Condition	Number
		Min.	Typ.	Max.			
Operating and Standby Currents							
Standby Current for Whole Device with Load	$I_{VS(OFF)}$	–	1	4	μA	¹⁾ $V_S = 18 \text{ V}$ $V_{OUT} = 0 \text{ V}$ $V_{in} = V_S$ $T_J \leq 85^\circ\text{C}$ See Page 35	P_6.1.1
Maximum Standby Current for Whole Device with Load	$I_{VS(OFF)}$	–	10	100	μA	$V_S = 18 \text{ V}$ $V_{OUT} = 0 \text{ V}$ $V_{in} = V_S$ $T_J \leq 150^\circ\text{C}$ See Page 35	P_6.1.2
Power Stage							
ON-State Resistance in Forward Condition	$R_{DS(ON)}$	–	4.4	5	$\text{m}\Omega$	$I_L = 20 \text{ A}$ $V_S - V_{in} \geq 5.8 \text{ V}$ $T_J = 150^\circ\text{C}$ See Page 35	P_6.1.3
ON-State Resistance in Forward Condition	$R_{DS(ON)}$	–	2.7	–	$\text{m}\Omega$	¹⁾ $I_L = 20 \text{ A}$ $V_S - V_{in} \geq 5.8 \text{ V}$ $T_J = 25^\circ\text{C}$	P_6.1.4
ON-State Resistance in Forward Condition, Low Battery Voltage	$R_{DS(ON)}$	–	6	20	$\text{m}\Omega$	$I_L = 12 \text{ A}$ $V_S - V_{in} \geq 3.1 \text{ V}$ $T_J = 150^\circ\text{C}$	P_6.1.5
ON-State Resistance in Forward Condition, Low Battery Voltage	$R_{DS(ON)}$	–	3.5	–	$\text{m}\Omega$	¹⁾ $I_L = 12 \text{ A}$ $V_S - V_{in} \geq 3.1 \text{ V}$ $T_J = 25^\circ\text{C}$	P_6.1.6
Nominal Load Current	$I_{L(NOM)}$	24	26	–	A	²⁾ $T_A = 85^\circ\text{C}$ $T_J \leq 150^\circ\text{C}$	P_6.1.7
Drain to Source Smart Clamp Voltage $V_{DS(CL)} = V_S - V_{OUT}$	$V_{DS(CL)}$	30	35	45	V	$I_{DS} = 10 \text{ mA}$ $T_J = 25^\circ\text{C}$ See Page 37	P_6.1.8
Drain to Source Smart Clamp Voltage $V_{DS(CL)} = V_S - V_{OUT}$	$V_{DS(CL)}$	35	39	50	V	$I_{DS} = 10 \text{ mA}$ $T_J = 150^\circ\text{C}$ See Page 37	P_6.1.9
Fast turn off detection voltage	$V_{DS(FAST)}$	–	28	–	V	¹⁾ See Page 16	P_6.1.10

Electrical Characteristics BTS50025-1TEA

Table 6-1 Electrical Characteristics: BTS50025-1TEA (cont'd)

$V_S = 5.8\text{ V to }18\text{ V}$, $T_J = -40^\circ\text{C to }+150^\circ\text{C}$ (unless otherwise specified)

For a given temperature or voltage range, typical values are specified at $V_S = 13.5\text{ V}$, $T_J = 25^\circ\text{C}$

Parameter	Symbol	Values			Unit	Note or Test Condition	Number
		Min.	Typ.	Max.			
Body diode Forward voltage	V_F	–	0.6	0.8	V	$I_{OUT} = -20\text{ A}$ $T_J = 150^\circ\text{C}$	P_6.1.11
Output Leakage Current	$I_{L(OFF)}$	–	1	4	μA	¹⁾ $V_S = 18\text{ V}$ $V_{OUT} = 0\text{ V}$ $V_{in} = V_S$ $T_J \leq 85^\circ\text{C}$ (10ms after $V_S = V_{IN}$)	P_6.1.12
Output Leakage Current	$I_{L(OFF)}$	–	10	100	μA	$V_S = 18\text{ V}$ $V_{OUT} = 0\text{ V}$ $V_{in} = V_S$ $T_J \leq 150^\circ\text{C}$ (10ms after $V_S = V_{IN}$)	P_6.1.13
Turn ON Slew Rate $V_{OUT} = 25\%$ to 50% V_S	dV_{ON}/dt	0.05	0.25	1	$\text{V}/\mu\text{s}$	$R_L = 0.68\ \Omega$ $V_S = 13.5\text{ V}$	P_6.1.14
Turn OFF Slew Rate $V_{OUT} = 50\%$ to 25% V_S	$-dV_{OFF}/dt$	0.05	0.25	1	$\text{V}/\mu\text{s}$	See Figure 5-1 See Page 36	P_6.1.15
Rising time during turn on V_{OUT} from 20% to 80% of V_S	t_r	10	50	150	μs		P_6.1.16
Falling time during turn off V_{OUT} from 80% to 20% of V_S	t_f	10	50	150	μs		P_6.1.17
Turn ON Time to $V_{OUT} = 20\%$ of V_S	$t_{ON(Delay)}$	10	50	250	μs		P_6.1.18
Turn OFF Time to $V_{OUT} = 80\%$ of V_S	$t_{OFF(Delay)}$	50	150	450	μs		P_6.1.19
Switch ON Energy	E_{ON}	–	5.5	–	mJ	¹⁾ $R_L = 0.68\ \Omega$ $V_S = 13.5\text{ V}$ See Page 37	P_6.1.20
Switch OFF Energy	E_{OFF}	–	4	–	mJ	¹⁾ $R_L = 0.68\ \Omega$ $V_S = 13.5\text{ V}$ See Page 37	P_6.1.21

Electrical Characteristics BTS50025-1TEA

Table 6-1 Electrical Characteristics: BTS50025-1TEA (cont'd)

$V_S = 5.8\text{ V to }18\text{ V}$, $T_J = -40^\circ\text{C to }+150^\circ\text{C}$ (unless otherwise specified)

For a given temperature or voltage range, typical values are specified at $V_S = 13.5\text{ V}$, $T_J = 25^\circ\text{C}$

Parameter	Symbol	Values			Unit	Note or Test Condition	Number
		Min.	Typ.	Max.			
Input Pin							
LOW Level Input Voltage	$V_{VS-VIN(L)}$	2.3	2.7	3.1	V		P_6.1.22
HIGH Level Input Voltage	$V_{VS-VIN(H)}$	4	4.8	5.8	V		P_6.1.23
Input Voltage Hysteresis	$V_{VS-VIN(HYS)}$	1.7	2.1	2.5	V		P_6.1.24
On stage Input Current	$I_{IN(ON)}$	1	2	4	mA	$V_S - V_{IN} = 18\text{ V}$, $V_S = 18\text{ V}$	P_6.1.25
LOW Level Input Current	$I_{IN(L)}$	100	-	-	μA	$V_{IN} = V_{in(L)}$	P_6.1.26
Input resistor	R_{in}	115	200	300	Ω	Built-in	P_6.1.27

Protection: Reverse Polarity

ON-State Resistance in Reverse Polarity	$R_{DS(REV)}$	-	5	10	m Ω	$V_S = 0\text{ V}$ $V_S - V_{IN} = -16\text{ V}$ $I_L = -20\text{ A}$ $T_J = 150^\circ\text{C}$	P_6.1.28
ON-State Resistance in Reverse Polarity	$R_{DS(REV)}$	-	4	-	m Ω	¹⁾ $V_S = 0\text{ V}$ $V_S - V_{IN} = -16\text{ V}$ $I_L = -20\text{ A}$ $T_J = 25^\circ\text{C}$ See Page 37	P_6.1.29

Protection: Overload

Current Trip Detection Level	$I_{CL(0)}$	65	82	100	A	$5.8\text{ V} < V_S - V_{IN} < 27\text{ V}$ See Figure 5-9	P_6.1.30
Current Trip Detection Level at low voltage	$I_{CL(0_UV)}$	12	82	120	A	$V_S = 3.1\text{ V}$	P_6.1.32
Current Trip Maximum Level	$I_{CL(1)}$	65	92	140	A	$dI_L/dt = 1\text{ A}/\mu\text{s}$ See Figure 5-9	P_6.1.33
Overload Shutdown Delay Time	$t_{OFF(TRIP)}$	-	7	-	μs	¹⁾ See Figure 5-9	P_6.1.34
Thermal Shutdown Temperature	$T_{J(TRIP)}$	150	175 ¹⁾	200 ¹⁾	$^\circ\text{C}$	See Figure 5-9 $3.1\text{ V} < V_S - V_{IN} < 27\text{ V}$	P_6.1.35
Over Power Shutdown Detection Level	$V_{DS(PSD)}$	650	900	1100	mV	¹⁾ See Figure 5-7	P_6.1.36
Over Power Shutdown Activation Level	$V_{VS-VIN(PSD)}$	3.8	4.3	5	V	¹⁾ See Figure 5-7	P_6.1.37
Over Power Shutdown Time	$t_{PSD(UV)}$	10	50	300	μs	See Figure 5-7	P_6.1.38

Electrical Characteristics BTS50025-1TEA

Table 6-1 Electrical Characteristics: BTS50025-1TEA (cont'd)

$V_S = 5.8 \text{ V to } 18 \text{ V}$, $T_J = -40^\circ\text{C to } +150^\circ\text{C}$ (unless otherwise specified)

For a given temperature or voltage range, typical values are specified at $V_S = 13.5 \text{ V}$, $T_J = 25^\circ\text{C}$

Parameter	Symbol	Values			Unit	Note or Test Condition	Number
		Min.	Typ.	Max.			
Diagnostic Function: Sense Pin							
Sense Signal Current in Fault Condition	$I_{IS(\text{FAULT})}$	5	12	18	mA	$V_S - V_{IS} \geq 3.5 \text{ V}$ Typ. and Max. value: $V_S - V_{IS} \geq 8 \text{ V}$	P_6.1.39
Sense Signal Saturation Current	$I_{IS(\text{LIM})}$	4.4	6.5	–	mA	¹⁾ $V_S - V_{IS} \geq 3.5 \text{ V}$	P_6.1.40

Electrical Characteristics BTS50025-1TEA

Table 6-1 Electrical Characteristics: BTS50025-1TEA (cont'd)

$V_S = 5.8\text{ V to }18\text{ V}$, $T_j = -40^\circ\text{C to }+150^\circ\text{C}$ (unless otherwise specified)

For a given temperature or voltage range, typical values are specified at $V_S = 13.5\text{ V}$, $T_j = 25^\circ\text{C}$

Parameter	Symbol	Values			Unit	Note or Test Condition	Number
		Min.	Typ.	Max.			
Diagnostic Function: Current Sense Ratio Signal in the Nominal Area, Stable Current Load Condition							
Current Sense Differential Ratio	dk_{ILIS}	15500	18000	20500	–	$I_{L3} = 60\text{ A}$ $I_{L1} = 0.2\text{ A}$ $V_S - V_{IS} \geq 3.5\text{ V}$ See Equation (5.4)	P_6.1.41
Calculated Sense Offset load Current $I_S = 0\text{ A}$, $T_j = -40^\circ\text{C}$	I_{L0}	-0.15	0	0.15	A	³⁾ $V_S - V_{IS} \geq 3.5\text{ V}$ See Figure 5-11	P_6.1.42
Calculated Sense Offset load Current $I_S = 0\text{ A}$, $T_j = 25^\circ\text{C}$	I_{L0}	-0.13	0	0.13	A	³⁾ $V_S - V_{IS} \geq 3.5\text{ V}$ See Figure 5-11	P_6.1.60
Calculated Sense Offset load Current $I_S = 0\text{ A}$, $T_j = 150^\circ\text{C}$	I_{L0}	-0.105	0	0.105	A	³⁾ $V_S - V_{IS} \geq 3.5\text{ V}$ See Figure 5-11	P_6.1.61
Calculated Sense Offset Current $I_L = I_{L0} = 0\text{ A}$, $T_j = -40^\circ\text{C}$	I_{IS0}	-7	0	9.7	μA	³⁾ $V_S - V_{IS} \geq 3.5\text{ V}$ $T_j = -40^\circ\text{C}$ See Figure 5-11	P_6.1.43
Calculated Sense Offset Current $I_L = I_{L0} = 0\text{ A}$, $T_j = 25^\circ\text{C}$	I_{IS0}	-5.95	0	8.25	μA	³⁾ $V_S - V_{IS} \geq 3.5\text{ V}$ $T_j = 25^\circ\text{C}$ See Figure 5-11	P_6.1.58
Calculated Sense Offset Current $I_L = I_{L0} = 0\text{ A}$, $T_j = 150^\circ\text{C}$	I_{IS0}	-4.9	0	6.8	μA	³⁾ $V_S - V_{IS} \geq 3.5\text{ V}$ $T_j = 150^\circ\text{C}$ See Figure 5-11	P_6.1.59
Sense Current $I_L = I_{L1} = 0.2\text{ A}$	I_{IS1}	2.3	10.8	22.6	μA	$V_S - V_{IS} \geq 3.5\text{ V}$ See Figure 5-11	P_6.1.44
Sense Current $I_L = I_{L2} = 20\text{ A}$	I_{IS2}	0.92	1.08	1.3	mA	$V_S - V_{IS} \geq 3.5\text{ V}$ See Figure 5-11	P_6.1.45
Sense Current $I_L = I_{L3} = 60\text{ A}$	I_{IS3}	2.78	3.24	3.88	mA	$V_S - V_{IS} \geq 3.5\text{ V}$ See Figure 5-11	P_6.1.46
Current Sense Ratio Spread between -40°C and 25°C for Repetitive Operation	$\Delta(dk_{ILIS(cal)(-40^\circ\text{C})})$	-1.5	0	+1.5	%	¹⁾ $(dk_{ILIS(cal)(-40^\circ\text{C})} - dk_{ILIS(cal)(25^\circ\text{C})}) / dk_{ILIS(cal)(25^\circ\text{C})}$ See Figure 5-13	P_6.1.47
Current Sense Ratio Spread between 150°C and 25°C for Repetitive Operation	$\Delta(dk_{ILIS(cal)(150^\circ\text{C})})$	-3.5	-0.8	+2	%	¹⁾ $(dk_{ILIS(cal)(150^\circ\text{C})} - dk_{ILIS(cal)(25^\circ\text{C})}) / dk_{ILIS(cal)(25^\circ\text{C})}$ See Figure 5-13	P_6.1.48

Electrical Characteristics BTS50025-1TEA

Table 6-1 Electrical Characteristics: BTS50025-1TEA (cont'd)

$V_S = 5.8\text{ V to }18\text{ V}$, $T_J = -40^\circ\text{C to }+150^\circ\text{C}$ (unless otherwise specified)

For a given temperature or voltage range, typical values are specified at $V_S = 13.5\text{ V}$, $T_J = 25^\circ\text{C}$

Parameter	Symbol	Values			Unit	Note or Test Condition	Number
		Min.	Typ.	Max.			
Diagnostic Function: Diagnostic Timing in Normal Condition							
Current Sense Settling Time until 90% and 110% of I_{IS} Stable after turn on	$t_{SIS(ON)_{90}}$	–	–	700	μs	$V_S = 13.5\text{ V}$ $R_L = 0.68\ \Omega$ See Figure 5-14	P_6.1.49
Current Sense Settling Time to I_{IS} Stable after turn on	$t_{SIS(ON)}$	–	–	1500	μs	$V_S = 13.5\text{ V}$ $R_L = 0.68\ \Omega$ See Figure 5-14	P_6.1.50
I_{IS} Leakage Current when IN Disabled	$I_{IS(OFF)}$	–	–	1	μA	$V_{IN} = V_S$ $R_{IS} = 1\text{ k}\Omega$ $T_J \leq 150^\circ\text{C}$	P_6.1.51
Current Sense Settling Time after Load Change	$t_{SIS(LC)}$	–	5	–	μs	¹⁾ $I_L \geq 0.2\text{ A}$	P_6.1.52

Diagnostic Function: Diagnostic Timing in Overload Condition

Fault Propagation Time for Short Circuit Detection	$t_{pIS(FAULT)}$	–	3	20	μs	See Figure 5-14	P_6.1.53
Fault Propagation Time for Over temperature Detection	$t_{FAULT(OT)}$	–	100	–	μs	¹⁾	P_6.1.55
Delay Time to Reset Fault Pin after Turning OFF V_{IN}	$t_{IN(RESETDELAY)}$	6	–	5000	μs	See Figure 5-14	P_6.1.54

1) Not subject to production test, specified by design.

2) Value is calculated from the parameters typ. $R_{thJA(2s2p)}$ with 65 K temperature increase, typ. and max. $R_{DS(ON)}$.

3) Value is calculated from the parameters dk_{ILIS} and I_{IS1} .

6.2 Typical Performance Characteristics

Standby Current for Whole Device with Load,
 $I_{VS(OFF)} = f(V_S, T_J), -40^{\circ}\text{C}, 85^{\circ}\text{C}, 150^{\circ}\text{C}$

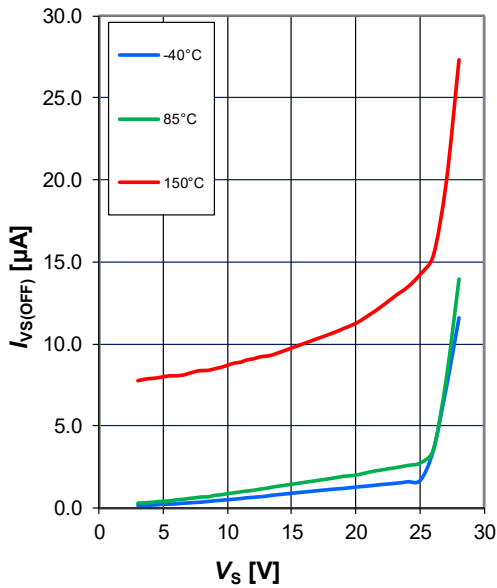

Standby Current for Whole Device with Load,
 $I_{VS(OFF)} = f(T_J) \text{ at } V_S = 13.5\text{ V}$

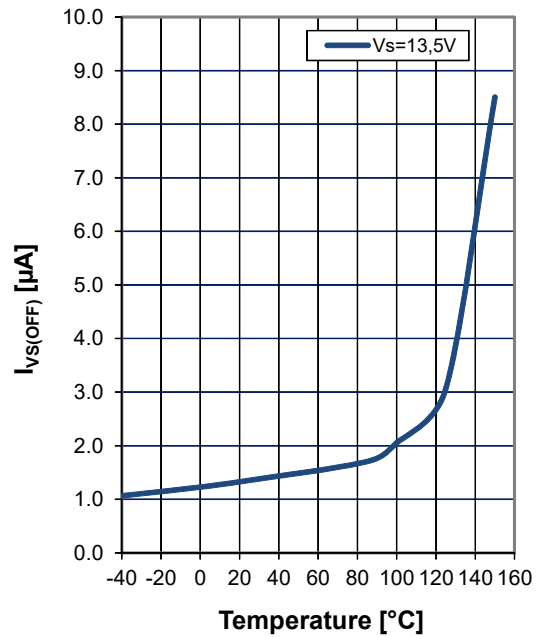

ON State Resistance

$R_{DS(ON)} = f(V_S - V_{IN}, T_J), I_L = 10\text{ A} \dots I_{CL}(0)\text{ min}; -40^{\circ}\text{C}, 25^{\circ}\text{C}, 150^{\circ}\text{C}$

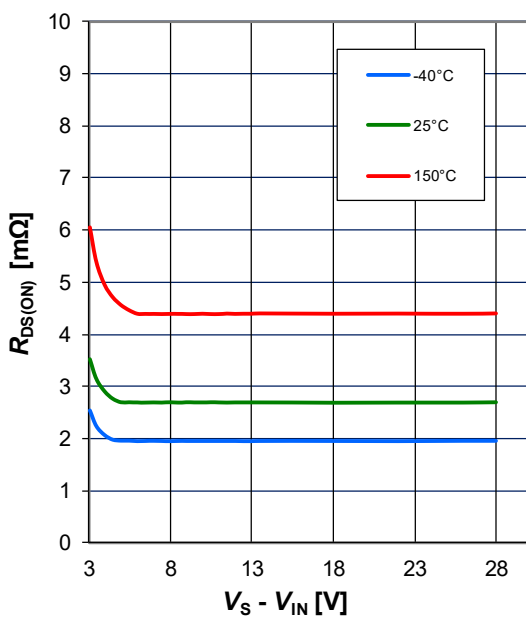

ON State Resistance

$R_{DS(ON)} = f(T_J), V_S - V_{IN} = 13.5\text{ V}, I_L = 10\text{ A} \dots I_{CL}(0)\text{ min}$

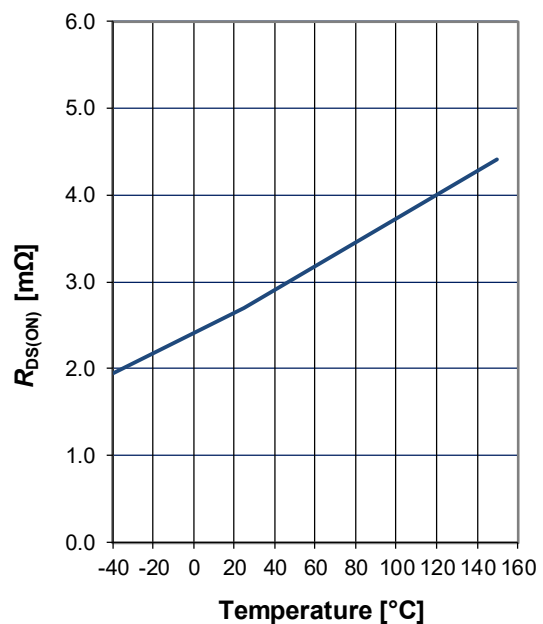

Electrical Characteristics BTS50025-1TEA

Turn ON Time

$t_{ON} = f(V_S, T_J), R_L = 0.68 \Omega$

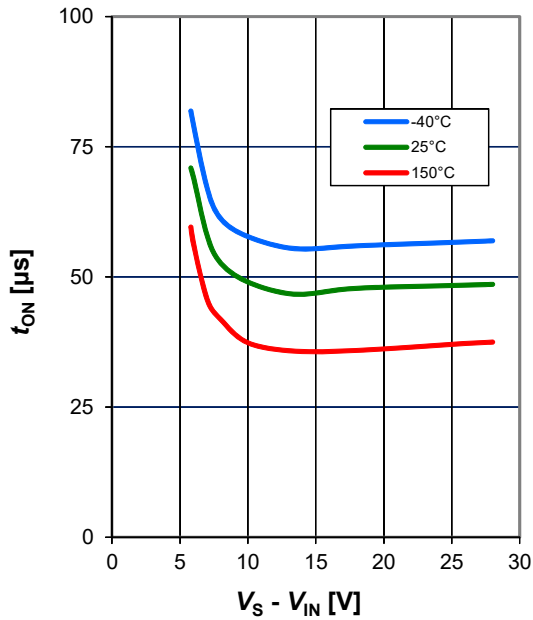

Turn OFF Time

$t_{OFF} = f(V_S, T_J), R_L = 0.68 \Omega$

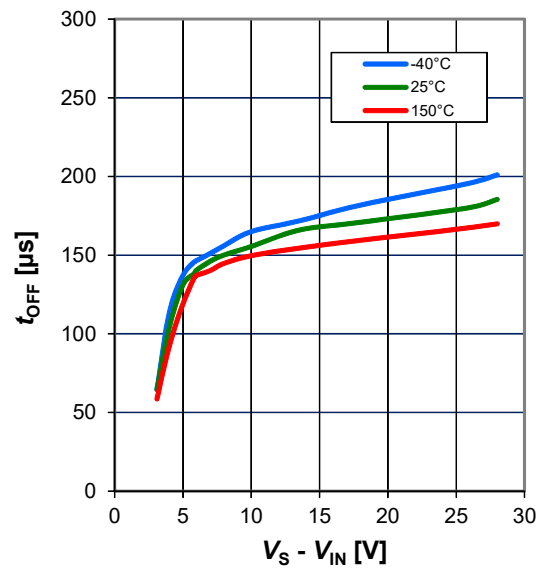

Slew Rate at Turn ON

$dV_{ON} / dt = f(V_S, T_J), R_L = 0.68 \Omega$

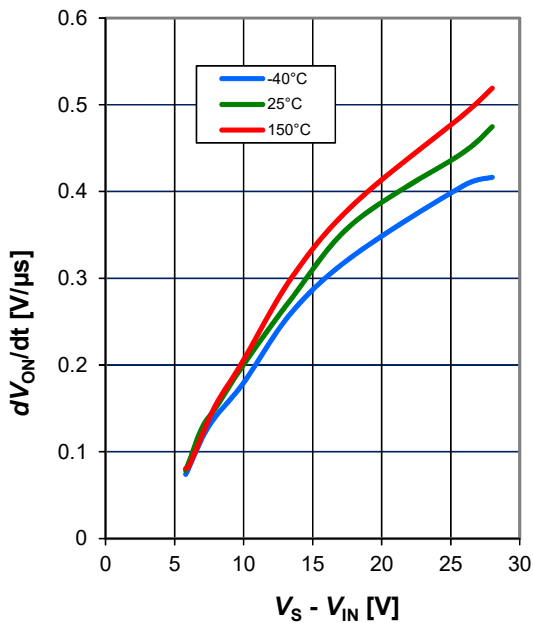

Slew Rate at Turn OFF

$dV_{OFF} / dt = f(V_S, T_J), R_L = 0.68 \Omega$

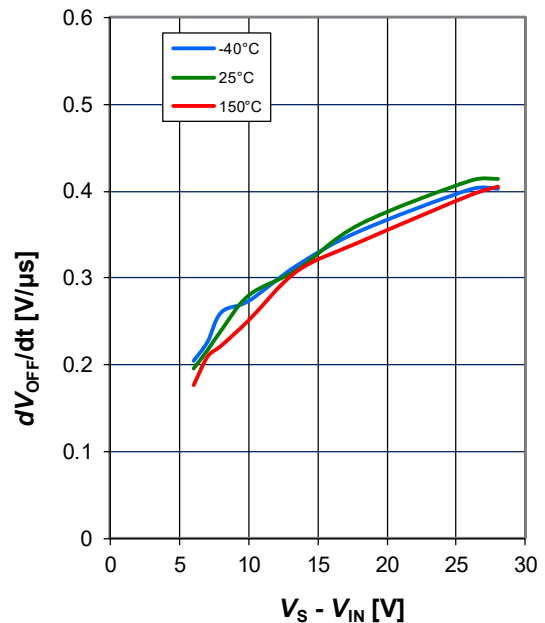

Electrical Characteristics BTS50025-1TEA

Switch ON Energy

$E_{ON} = f(V_S, T_J), R_L = 0.68 \Omega$

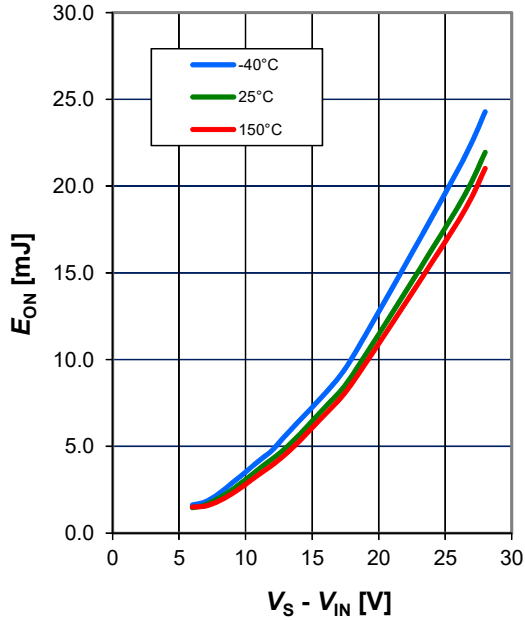

Switch OFF Energy

$E_{OFF} = f(V_S, T_J), R_L = 0.68 \Omega$

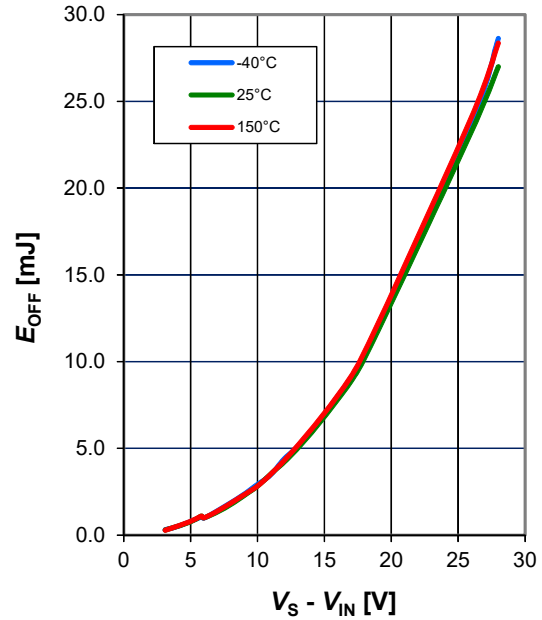

Drain to Source Clamp Voltage

$V_{DS(CL)} = f(T_J), I_L = 10 \text{ mA}$

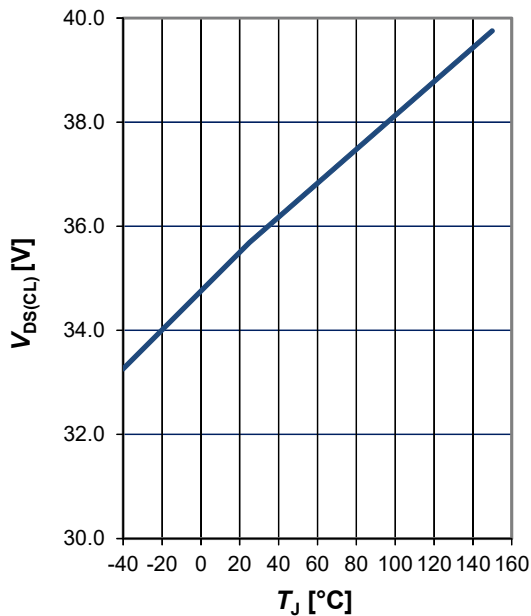

Resistance in ReverSave™

$R_{DS(REV)} = f(V_S, T_J), I_L = -20 \text{ A}$

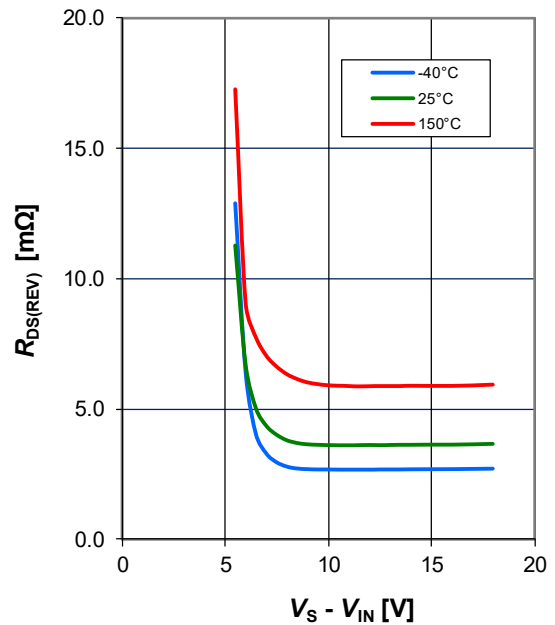

Electrical Characteristics BTS50025-1TEA

Input Current

$I_{IN} = f(V_S, T_J)$

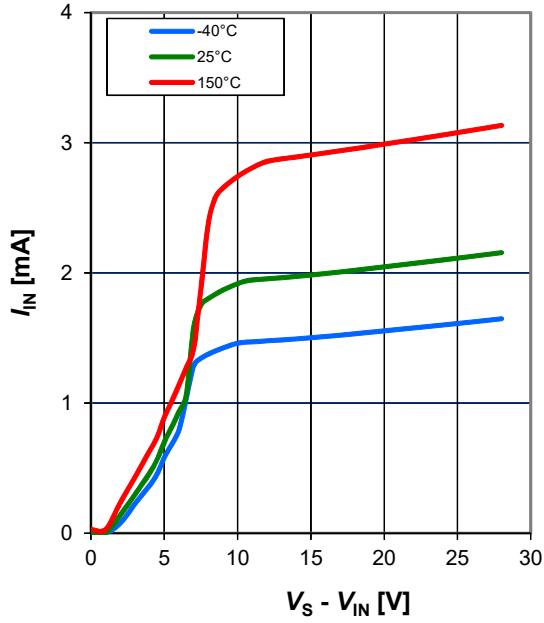

Time to Shutdown

$t_{SHUTDOWN} \text{ Vs } I_L, R_{thJA(2s2p)}$

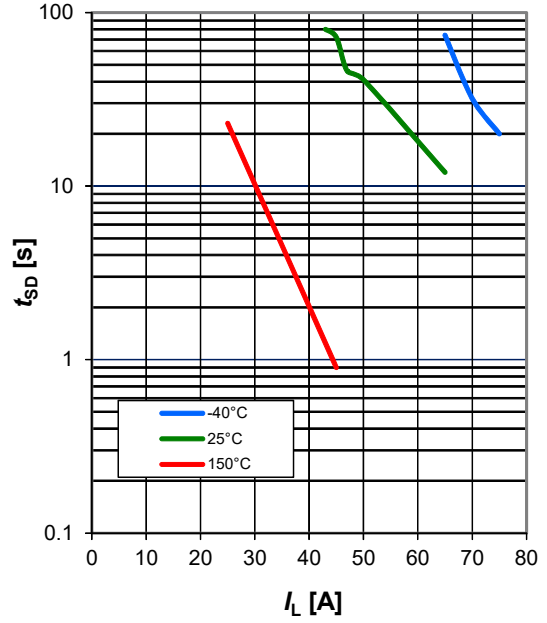

$V_{IS(FAULT)}$ min. Vs V_S ; $R_{IS} = 500\Omega, 1\text{ k}\Omega, 2.2\text{ k}\Omega$

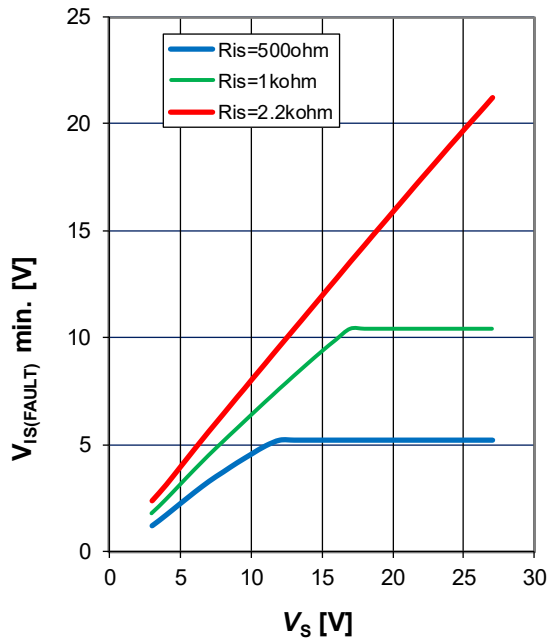

dK_{ILIS} Vs T_J

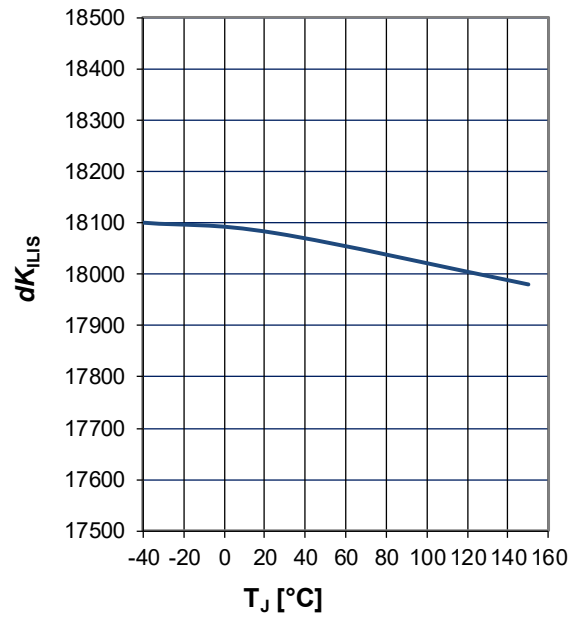

Electrical Characteristics BTS50025-1TEA

$$I_{CL(0)} = f(V_S, T_J)$$

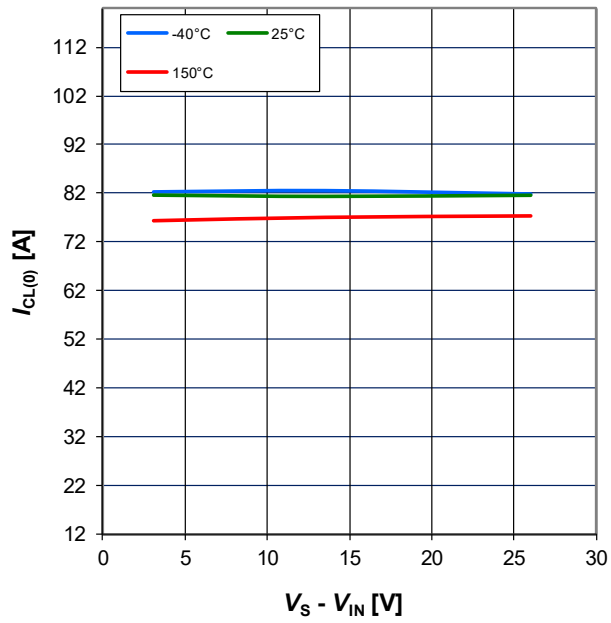

Application Information

7 Application Information

Note: The following information is given as a hint for the implementation of the device only and shall not be regarded as a description or warranty of a certain functionality, condition or quality of the device. This is a very simplified example of an application circuit. The function must be verified in the real application.

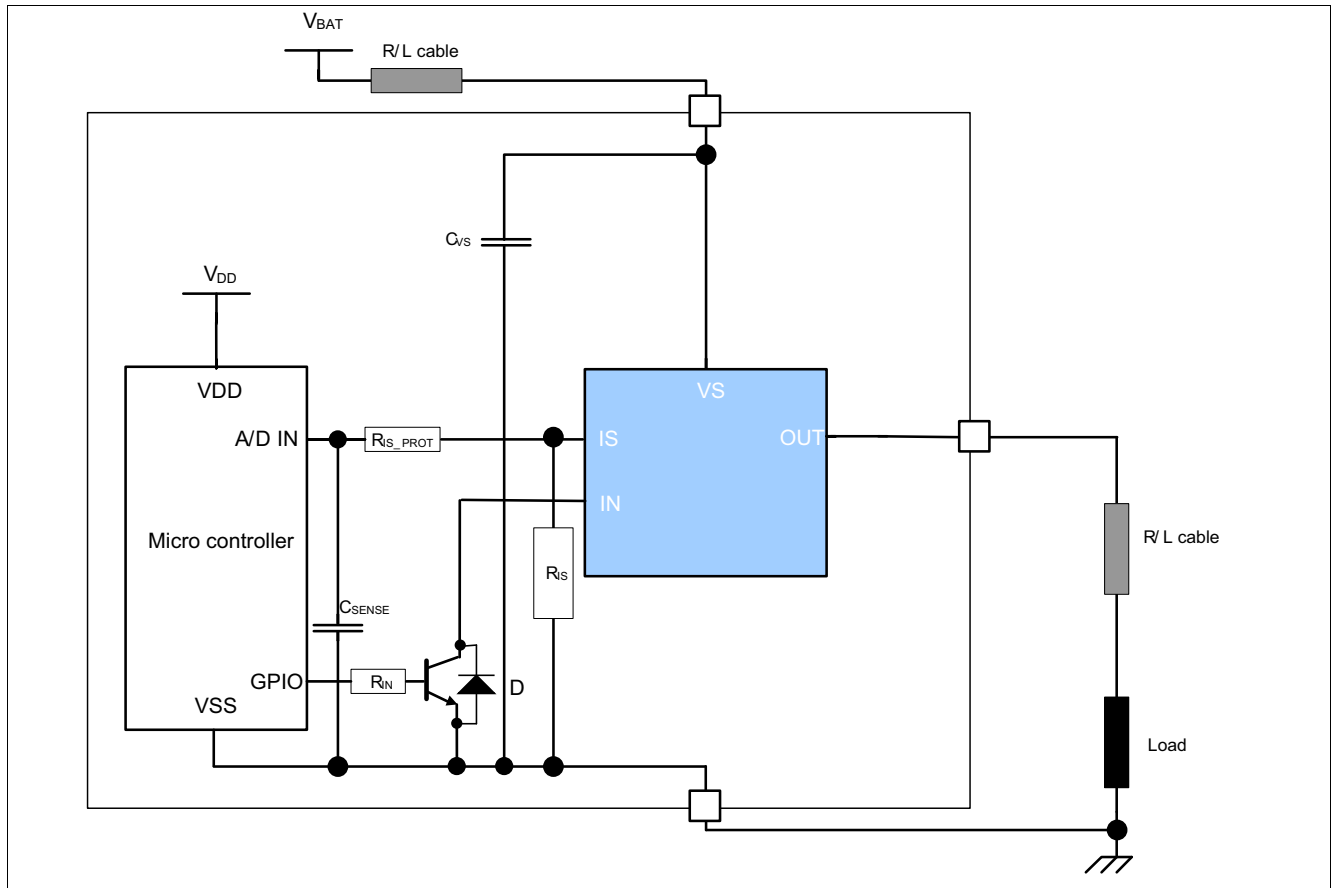

Figure 7-1 Application Diagram with BTS50025-1TEA

Application Information

Table 7-1 Bill of material

Reference	Value	Purpose
R_{IN}	4.7 k Ω	Protection of the microcontroller during reverse polarity and during loss of ground
R_{IS}	1 k Ω	Sense resistor
R_{IS_PROT}	10 k Ω	Protection of the microcontroller during fault condition Protection of the BTS50025-1TEA and the microcontroller during reverse polarity
C_{SENSE}	10 nF	Sense signal filtering
C_{VS}	100 nF	Improved EMC behavior (in layout, pls. place close to the pins)
D		To turn on the Power Mosfet during reverse polarity

7.1 Further Application Information

- Please contact us for information regarding the pin FMEA
- For further information you may contact <http://www.infineon.com/>

8 Package Information

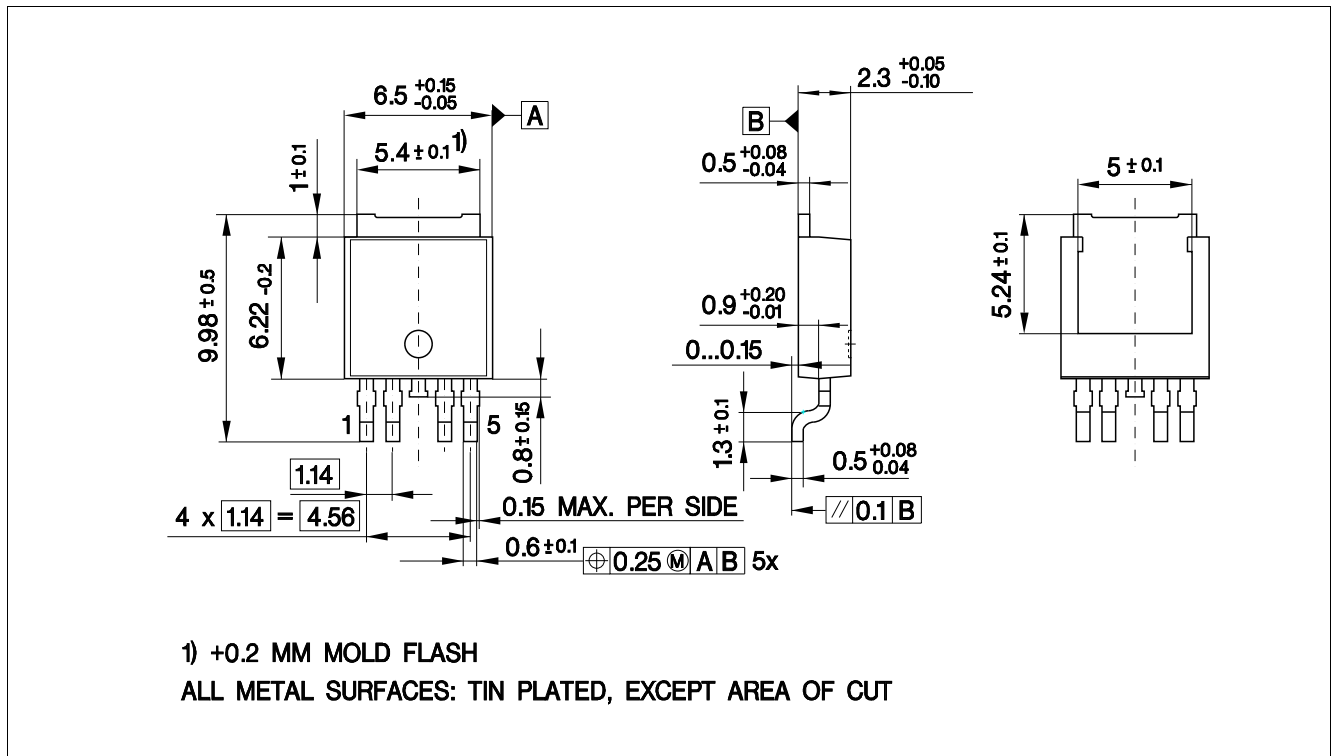

Figure 8-1 PG-TO-252-5-11 (RoHS-Compliant)¹⁾

Green Product (RoHS compliant)

To meet the world-wide customer requirements for environmentally friendly products and to be compliant with government regulations the device is available as a green product. Green products are RoHS-Compliant (i.e. Pb-free finish on leads and suitable for Pb-free soldering according to IPC/JEDEC J-STD-020).

1) Dimensions in mm

Revision History

9 Revision History

Revision	Date	Changes
1.1	2019-09-30	Chapter “Electrical Characteristics” <ul style="list-style-type: none">• Change P_6.1.30 and P_6.1.33 minimum limit from 60A to 65A• Change P_6.1.30 and P_6.1.32 typical value from 80A to 82A• Change P_6.1.33 typical value from 87A to 92A
1.0	2018-08-16	Datasheet created

Trademarks of Infineon Technologies AG

μ HVIC™, μ IPM™, μ PFC™, AU-ConvertIR™, AURIX™, C166™, CanPAK™, CIPOS™, CIPURSE™, CoolDP™, CoolGaN™, COOLiR™, CoolMOS™, CoolSET™, CoolSiC™, DAVE™, DI-POL™, DirectFET™, DrBlade™, EasyPIM™, EconoBRIDGE™, EconoDUAL™, EconoPACK™, EconoPIM™, EiceDRIVER™, eupec™, FCOS™, GaNpowIR™, HEXFET™, HITFET™, HybridPACK™, iMOTION™, IRAM™, ISOFACE™, IsoPACK™, LEDriviR™, LITIX™, MIPAQ™, ModSTACK™, my-d™, NovalithIC™, OPTIGA™, OptiMOS™, ORIGA™, PowIRaudio™, PowIRstage™, PrimePACK™, PrimeSTACK™, PROFET™, PRO-SIL™, RASIC™, REAL3™, SmartLEWIS™, SOLID FLASH™, SPOC™, StrongIRFET™, SupIRBuck™, TEMPFET™, TRENCHSTOP™, TriCore™, UHVIC™, XHP™, XMC™.

Trademarks updated November 2015

Other Trademarks

All referenced product or service names and trademarks are the property of their respective owners.

Edition 2019-09-30

Published by

Infineon Technologies AG

81726 Munich, Germany

© 2019 Infineon Technologies AG.

All Rights Reserved.

Do you have a question about any aspect of this document?

Email: erratum@infineon.com

IMPORTANT NOTICE

The information given in this document shall in no event be regarded as a guarantee of conditions or characteristics ("Beschaffheitsgarantie").

With respect to any examples, hints or any typical values stated herein and/or any information regarding the application of the product, Infineon Technologies hereby disclaims any and all warranties and liabilities of any kind, including without limitation warranties of non-infringement of intellectual property rights of any third party.

In addition, any information given in this document is subject to customer's compliance with its obligations stated in this document and any applicable legal requirements, norms and standards concerning customer's products and any use of the product of Infineon Technologies in customer's applications.

The data contained in this document is exclusively intended for technically trained staff. It is the responsibility of customer's technical departments to evaluate the suitability of the product for the intended application and the completeness of the product information given in this document with respect to such application.

For further information on technology, delivery terms and conditions and prices, please contact the nearest Infineon Technologies Office (www.infineon.com).

WARNINGS

Due to technical requirements products may contain dangerous substances. For information on the types in question please contact your nearest Infineon Technologies office.

Except as otherwise explicitly approved by Infineon Technologies in a written document signed by authorized representatives of Infineon Technologies, Infineon Technologies' products may not be used in any applications where a failure of the product or any consequences of the use thereof can reasonably be expected to result in personal injury.