

PROFET™ + 12V

BTS5200-4EKA

Smart High-Side Power Switch
Quad Channel, 200mΩ

Data Sheet

PROFET™+ 12V
Rev. 1.0, 2014-02-06

Automotive Power

Table of Contents

1	Overview	4
2	Block Diagram	6
3	Pin Configuration	7
3.1	Pin Assignment	7
3.2	Pin Definitions and Functions	7
3.3	Voltage and Current Definition	8
4	General Product Characteristics	9
4.1	Absolute Maximum Ratings	9
4.2	Functional Range	11
4.3	Thermal Resistance	12
4.3.1	PCB set up	12
4.3.2	Thermal Impedence	13
5	Power Stage	14
5.1	Output ON-state Resistance	14
5.2	Turn ON/OFF Characteristics with Resistive Load	14
5.3	Inductive Load	15
5.3.1	Output Clamping	15
5.3.2	Maximum Load Inductance	15
5.4	Inverse Current Capability	16
5.5	Electrical Characteristics Power Stage	18
6	Protection Functions	20
6.1	Loss of Ground Protection	20
6.2	Undervoltage Protection	20
6.3	Overvoltage Protection	21
6.4	Reverse Polarity Protection	22
6.5	Overload Protection	22
6.5.1	Current Limitation	22
6.5.2	Temperature Limitation in the Power DMOS	23
6.5.3	Short Circuit Appearance with Channels in Parallel	24
6.6	Electrical Characteristics for the Protection Functions	25
7	Diagnostic Functions	26
7.1	IS Pin	26
7.2	SENSE Signal in Different Operating Modes	27
7.3	SENSE Signal in the Nominal Current Range	27
7.3.1	SENSE Signal Variation as a Function of Temperature and Load Current	28
7.3.2	SENSE Signal Timing	29
7.3.3	SENSE Signal in Open Load	30
7.3.3.1	Open Load in ON Diagnostic	30
7.3.3.2	Open Load in OFF Diagnostic	30
7.3.3.3	Open Load Diagnostic Timing	31
7.3.4	SENSE Signal in Short Circuit to V_S	32
7.3.5	SENSE Signal in Case of Overload	32
7.3.6	SENSE Signal in Case of Inverse Current	32
7.4	Electrical Characteristics Diagnostic Function	33
8	Input Pins	36
8.1	Input Circuitry	36

Table of Contents

8.2	DEN / DSEL0,1 Pin	36
8.3	Input Pin Voltage	36
8.4	Electrical Characteristics	37
9	Characterization Results	38
9.1	General Product Characteristics	38
9.2	Power Stage	39
9.3	Protection Functions	41
9.4	Diagnostic Mechanism	42
9.5	Input Pins	43
10	Application Information	44
10.1	Further Application Information	46
11	Package Outlines	47
12	Revision History	48



1 Overview

Application

- Suitable for resistive, inductive and capacitive loads
- Replaces electromechanical relays, fuses and discrete circuits
- Most suitable for loads with high inrush current, such as lamps

Basic Features

- Quad channel device
- Very low stand-by current
- 3.3 V and 5 V compatible logic inputs
- Electrostatic discharge protection (ESD)
- Optimized electromagnetic compatibility
- Logic ground independent from load ground
- Very low power DMOS leakage current in OFF state
- Green product (RoHS compliant)
- AEC qualified

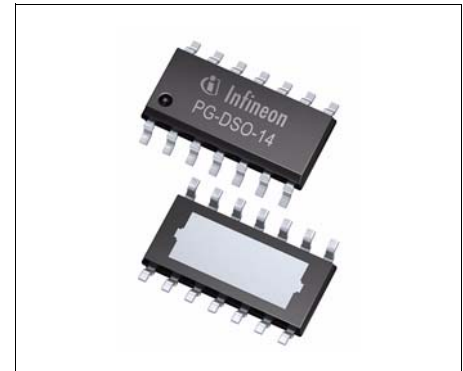

PG-DSO-14-48-EP

Description

The BTS5200-4EKA is a 200 mΩ quad channel Smart High-Side Power Switch, embedded in a PG-DSO-14-48-EP, Exposed Pad package, providing protective functions and diagnosis. The power transistor is built by an N-channel vertical power MOSFET with charge pump. The device is integrated in Smart6 technology. It is specially designed to drive lamps up to R5W, as well as LEDs in the harsh automotive environment.

Table 1 Product Summary

Parameter	Symbol	Value
Operating voltage range	$V_{S(OP)}$	5 V ... 28 V
Maximum supply voltage	$V_{S(LD)}$	41 V
Maximum ON state resistance at $T_J = 150\text{ °C}$ per channel	$R_{DS(ON)}$	400 mΩ
Nominal load current (one channel active)	$I_{L(NOM)1}$	1 A
Nominal load current (all channels active)	$I_{L(NOM)2}$	0.8 A
Typical current sense ratio	k_{ILIS}	300
Minimum current limitation	$I_{L5(SC)}$	5.6 A
Maximum standby current with load at $T_J = 25\text{ °C}$	$I_{S(OFF)}$	500 nA

Type	Package	Marking
BTS5200-4EKA	PG-DSO-14-48-EP	BTS5200-4EKA

Diagnostic Functions

- Proportional load current sense multiplexed for the 4 channels
- Open load detection in ON and OFF
- Short circuit to battery and ground indication
- Overtemperature switch off detection
- Stable diagnostic signal during short circuit
- Enhanced k_{ILIS} dependency with temperature and load current

Protection Functions

- Stable behavior during undervoltage
- Reverse polarity protection with external components
- Secure load turn-off during logic ground disconnection with external components
- Overtemperature protection with restart
- Overvoltage protection with external components
- Enhanced short circuit operation
- Voltage dependent current limitation

2 Block Diagram

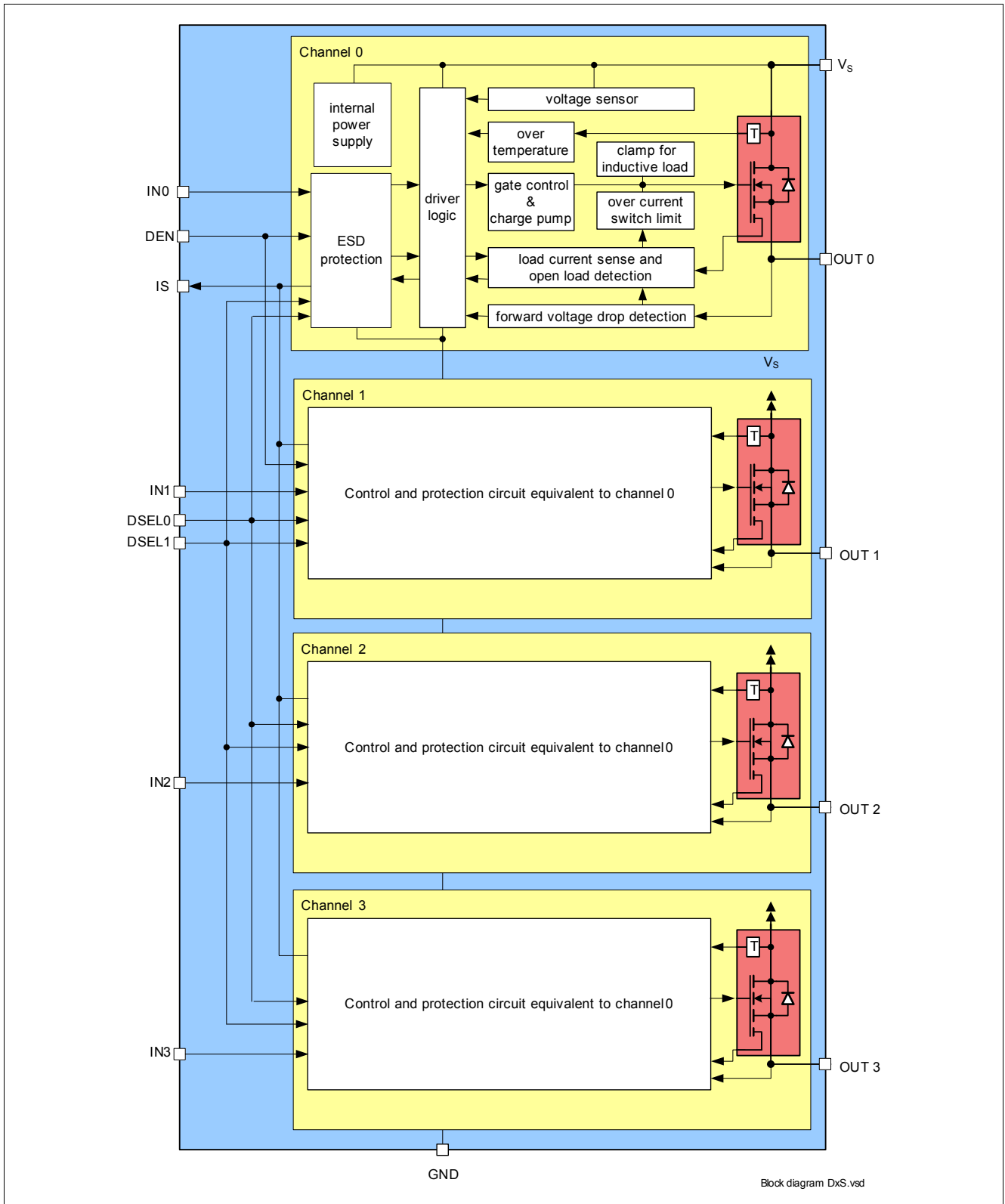

Figure 1 Block Diagram for the BTS5200-4EKA

3 Pin Configuration

3.1 Pin Assignment

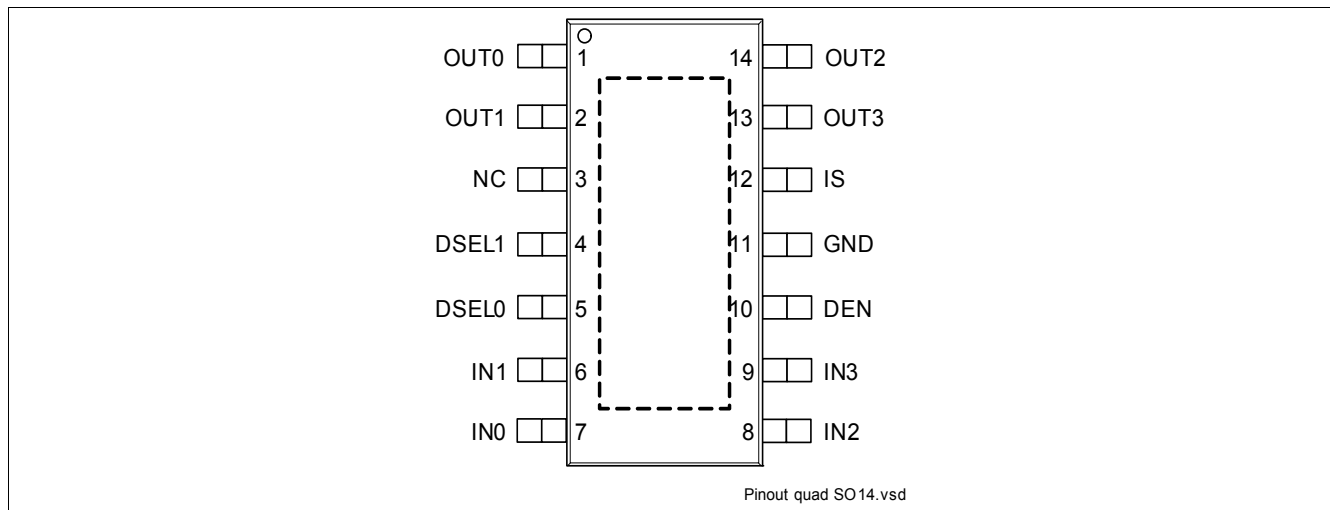

Figure 2 Pin Configuration

3.2 Pin Definitions and Functions

Pin	Symbol	Function
1	OUT0	OUTput 0 ; Protected high side power output channel 0 ¹⁾
2	OUT1	OUTput 1 ; Protected high side power output channel 1 ¹⁾
3	NC	Not Connected ; No internal connection to the chip
4	DSEL1	Diagnostic SElection ; Digital signal to select the channel to be diagnosed
5	DSEL0	Diagnostic SElection ; Digital signal to select the channel to be diagnosed
6	IN1	INput channel 1 ; Input signal for channel 1 activation
7	IN0	INput channel 0 ; Input signal for channel 0 activation
8	IN2	INput channel 2 ; Input signal for channel 2 activation
9	IN3	INput channel 3 ; Input signal for channel 3 activation
10	DEN	Diagnostic ENable ; Digital signal to enable/disable the diagnosis of the device
11	GND	GrouND ; Ground connection
12	IS	Sense ; Sense current of the selected channel
13	OUT3	OUTput 3 ; Protected high side power output channel 3 ¹⁾
14	OUT2	OUTput 2 ; Protected high side power output channel 2 ¹⁾
Cooling Tab	V_s	Voltage Supply ; Battery voltage

1) All PCB traces that are connected to the output pin have to be designed to withstand the maximum current which can flow.

3.3 Voltage and Current Definition

Figure 3 shows all terms used in this data sheet, with associated convention for positive values.

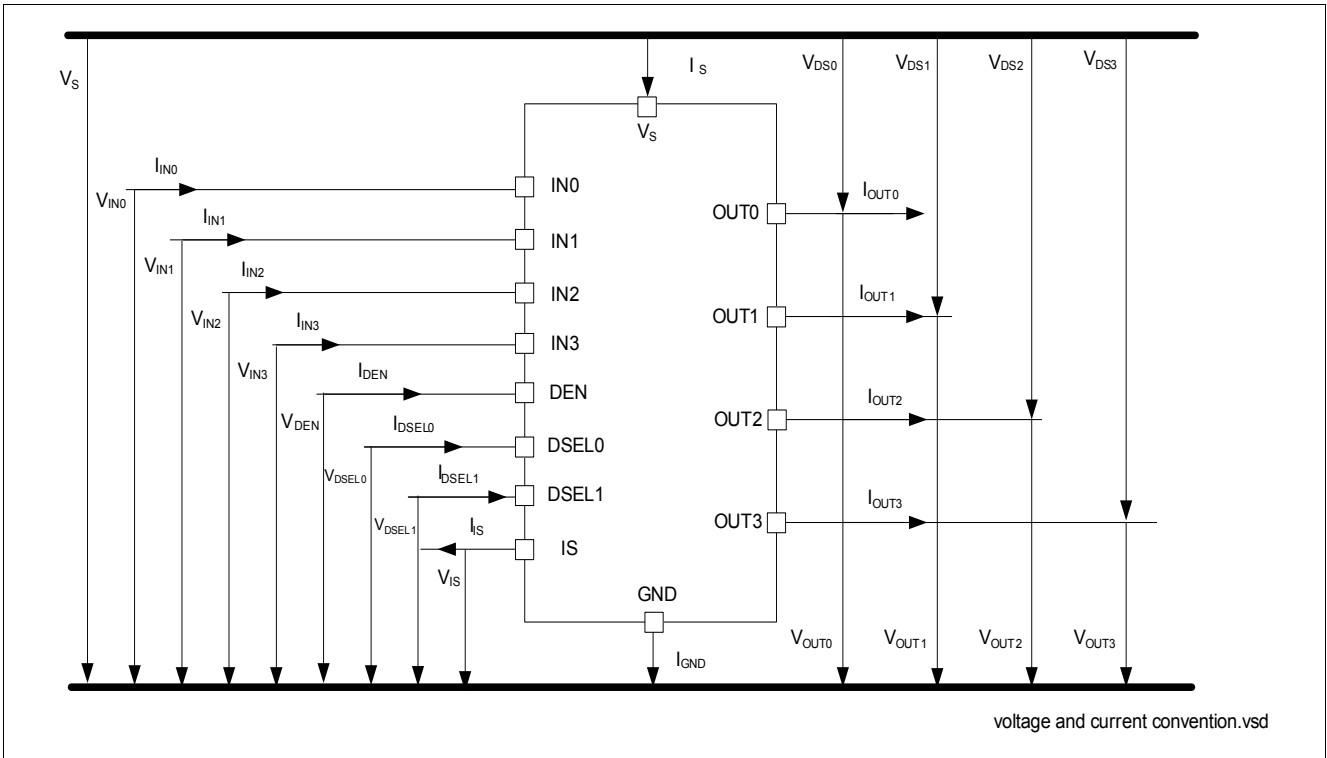

Figure 3 Voltage and Current Definition

4 General Product Characteristics

4.1 Absolute Maximum Ratings

Table 2 Absolute Maximum Ratings ¹⁾
 $T_J = -40^\circ\text{C}$ to 150°C ; (unless otherwise specified)

Parameter	Symbol	Values			Unit	Note / Test Condition	Number
		Min.	Typ.	Max.			
Supply Voltages							
Supply voltage	V_S	-0.3	–	28	V	–	P_4.1.1
Reverse polarity voltage	$-V_{S(\text{REV})}$	0	–	16	V	$t < 2$ min $T_A = 25^\circ\text{C}$ $R_L \geq 25 \Omega$ $R_{\text{GND}} = 150 \Omega$	P_4.1.2
Supply voltage for short circuit protection	$V_{\text{BAT(SC)}}$	0	–	24	V	²⁾ $R_{\text{ECU}} = 20 \text{ m}\Omega$ $R_{\text{Cable}} = 16 \text{ m}\Omega/\text{m}$ $L_{\text{Cable}} = 1 \mu\text{H}/\text{m}$, $l = 0$ or 5 m See Chapter 6 and Figure 28	P_4.1.3
Supply voltage for Load dump protection	$V_{S(\text{LD})}$	–	–	41	V	³⁾ $R_1 = 2 \Omega$ $R_L = 25 \Omega$	P_4.1.12
Short Circuit Capability							
Permanent short circuit IN pin toggles	n_{RSC1}	–	–	100	k cycles	⁴⁾ $t_{\text{ON}} = 300\text{ms}$	P_4.1.4
Input Pins							
Voltage at INPUT pins	V_{IN}	-0.3 –	–	6 7	V	– $t < 2$ min	P_4.1.13
Current through INPUT pins	I_{IN}	-2	–	2	mA	–	P_4.1.14
Voltage at DEN pin	V_{DEN}	-0.3 –	–	6 7	V	– $t < 2$ min	P_4.1.15
Current through DEN pin	I_{DEN}	-2	–	2	mA	–	P_4.1.16
Voltage at DSEL pin	V_{DSEL}	-0.3 –	–	6 7	V	– $t < 2$ min	P_4.1.17
Current through DSEL pin	I_{DSEL}	-2	–	2	mA	–	P_4.1.18
Sense Pin							
Voltage at IS pin	V_{IS}	-0.3	–	V_S	V	–	P_4.1.19
Current through IS pin	I_{IS}	-25	–	50	mA	–	P_4.1.20
Power Stage							
Load current	$ I_L $	–	–	$I_{L(\text{LIM})}$	A	–	P_4.1.21
Power dissipation (DC)	P_{TOT}	–	–	1.4	W	$T_A = 85^\circ\text{C}$ $T_J < 150^\circ\text{C}$	P_4.1.22

Table 2 Absolute Maximum Ratings (cont'd)¹⁾
 $T_J = -40^\circ\text{C}$ to 150°C ; (unless otherwise specified)

Parameter	Symbol	Values			Unit	Note / Test Condition	Number
		Min.	Typ.	Max.			
Maximum energy dissipation Single pulse (one channel)	E_{AS}	–	–	50	mJ	$I_{L(0)} = 0.5\text{ A}$ $T_{J(0)} = 150^\circ\text{C}$ $V_S = 13.5\text{ V}$	P_4.1.23
Maximum Energy dissipation repetitive pulse	E_{AR}	–	–	20	mJ	1Mio cycles $T_A < 105^\circ\text{C}$ $V_S = 13.5\text{ V}$ $I_{L(0)} = 350\text{ mA}$	P_4.1.25
Voltage at power transistor	V_{DS}	–	–	41	V	–	P_4.1.26
Currents							
Current through ground pin	I_{GND}	-10 -150	–	10 20	mA	– $t < 2\text{ min}$	P_4.1.27
Temperatures							
Junction temperature	T_J	-40	–	150	$^\circ\text{C}$	–	P_4.1.28
Storage temperature	T_{STG}	-55	–	150	$^\circ\text{C}$	–	P_4.1.30
ESD Susceptibility							
ESD susceptibility (all pins)	V_{ESD}	-2	–	2	kV	⁵⁾ HBM	P_4.1.31
ESD susceptibility OUT Pin vs. GND and V_S connected	V_{ESD}	-4	–	4	kV	⁵⁾ HBM	P_4.1.32
ESD susceptibility	V_{ESD}	-500	–	500	V	⁶⁾ CDM	P_4.1.33
ESD susceptibility pin (corner pins)	V_{ESD}	-750	–	750	V	⁶⁾ CDM	P_4.1.34

1) Not subject to production test. Specified by design.

2) Hardware set-up in accordance to AEC Q100-012 and AEC Q101-006.

3) $V_{S(LD)}$ is setup without the DUT connected to the generator per ISO 7637-1.

4) EOL tests according to AECQ100-012. Threshold limit for short circuit failures: 100 ppm. Please refer to the legal disclaimer for short-circuit capability at the end of this document.

5) ESD susceptibility HBM according to ANSI/ESDA/JEDEC JS-001

6) "CDM" ESDA STM5.3.1 or ANSI/ESD S.5.3.1

Notes

1. Stresses above the ones listed here may cause permanent damage to the device. Exposure to absolute maximum rating conditions for extended periods may affect device reliability.
2. Integrated protection functions are designed to prevent IC destruction under fault conditions described in the data sheet. Fault conditions are considered as "outside" normal operating range. Protection functions are not designed for continuous repetitive operation.

4.2 Functional Range

Table 3 Functional Range $T_J = -40^\circ\text{C}$ to 150°C ; (unless otherwise specified)

Parameter	Symbol	Values			Unit	Note / Test Condition	Number
		Min.	Typ.	Max.			
Nominal operating voltage	V_{NOM}	8	13.5	18	V	–	P_4.2.1
Extended operating voltage	$V_{\text{S(OP)}}$	5	–	28	V	²⁾ $V_{\text{IN}} = 4.5\text{ V}$ $R_{\text{L}} = 25\ \Omega$ $V_{\text{DS}} < 0.5\text{ V}$	P_4.2.2
Minimum functional supply voltage	$V_{\text{S(OP)_MIN}}$	3.5	4.3	5	V	¹⁾ $V_{\text{IN}} = 4.5\text{ V}$ $R_{\text{L}} = 25\ \Omega$ From $I_{\text{OUT}} = 0\text{ A}$ to $V_{\text{DS}} < 0.5\text{ V}$;	P_4.2.3
Undervoltage shutdown	$V_{\text{S(UV)}}$	2.6	3.5	4.1	V	¹⁾ $V_{\text{IN}} = 4.5\text{ V}$ $V_{\text{DEN}} = 0\text{ V}$ $R_{\text{L}} = 25\ \Omega$ From $V_{\text{DS}} < 1\text{ V}$; to $I_{\text{OUT}} = 0\text{ A}$ See Chapter 9.1	P_4.2.4
Undervoltage shutdown hysteresis	$V_{\text{S(UV)_HYS}}$	–	850	–	mV	²⁾ –	P_4.2.13
Operating current All channels active	I_{GND_4}	–	4	11	mA	$V_{\text{IN}} = 5.5\text{ V}$ $V_{\text{DEN}} = 5.5\text{ V}$ Device in $R_{\text{DS(ON)}}$ $V_{\text{S}} = 18\text{ V}$ See Chapter 9.1	P_4.2.6
Standby current for whole device with load (ambiente)	$I_{\text{S(OFF)}}$	–	0.1	0.5	μA	¹⁾ $V_{\text{S}} = 18\text{ V}$ $V_{\text{OUT}} = 0\text{ V}$ V_{IN} floating V_{DEN} floating $T_J \leq 85^\circ\text{C}$	P_4.2.7
Maximum standby current for whole device with load	$I_{\text{S(OFF)_150}}$	–	–	10	μA	$V_{\text{S}} = 18\text{ V}$ $V_{\text{OUT}} = 0\text{ V}$ V_{IN} floating V_{DEN} floating $T_J = 150^\circ\text{C}$	P_4.2.10
Standby current for whole device with load, diagnostic active	$I_{\text{S(OFF)_DEN}}$	–	1.2	–	mA	²⁾ $V_{\text{S}} = 18\text{ V}$ $V_{\text{OUT}} = 0\text{ V}$ V_{IN} floating $V_{\text{DEN}} = 5.5\text{ V}$	P_4.2.8

1) Test at $T_J = -40^\circ\text{C}$ only

2) Not subject to production test. Specified by design.

Note: Within the functional range the IC operates as described in the circuit description. The electrical characteristics are specified within the conditions given in the related electrical characteristics table.

4.3 Thermal Resistance

Table 4 Thermal Resistance

Parameter	Symbol	Values			Unit	Note / Test Condition	Number
		Min.	Typ.	Max.			
Junction to soldering point	R_{thJS}	–	5	–	K/W	1)	P_4.3.1
Junction to ambient All channels active	R_{thJA}	–	40	–	K/W	1)2)	P_4.3.2

- 1) Not subject to production test. Specified by design.
- 2) Specified R_{thja} value is according to JEDEC JESD51-2,-5,-7 at natural convection on FR4 2s2p board; The product (chip + package) was simulated on a 76.4 x 114.3 x 1.5 mm board with 2 inner copper layers (2 x 70 μ m Cu, 2 x 35 μ m Cu). Where applicable, a thermal via array under the exposed pad contacts the first inner copper layer. Please refer to [Figure 4](#).

4.3.1 PCB set up

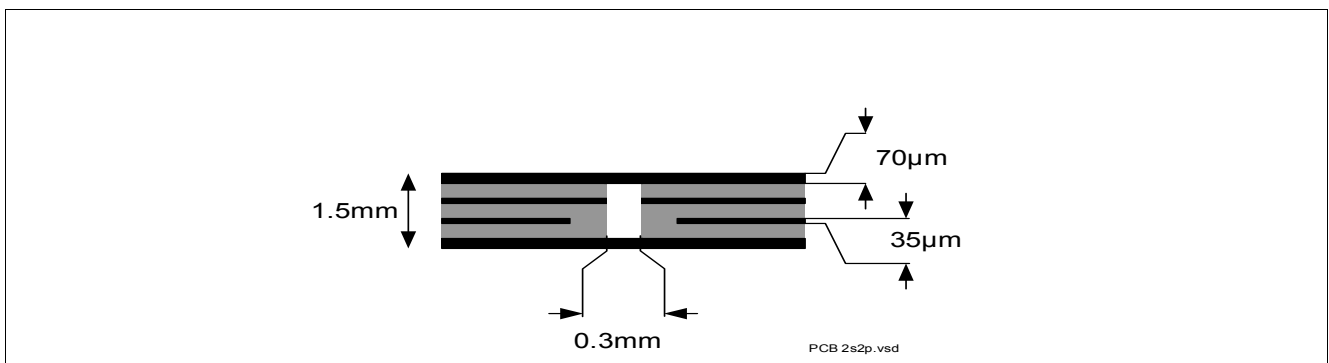

Figure 4 2s2p PCB Cross Section

4.3.2 Thermal Impedence

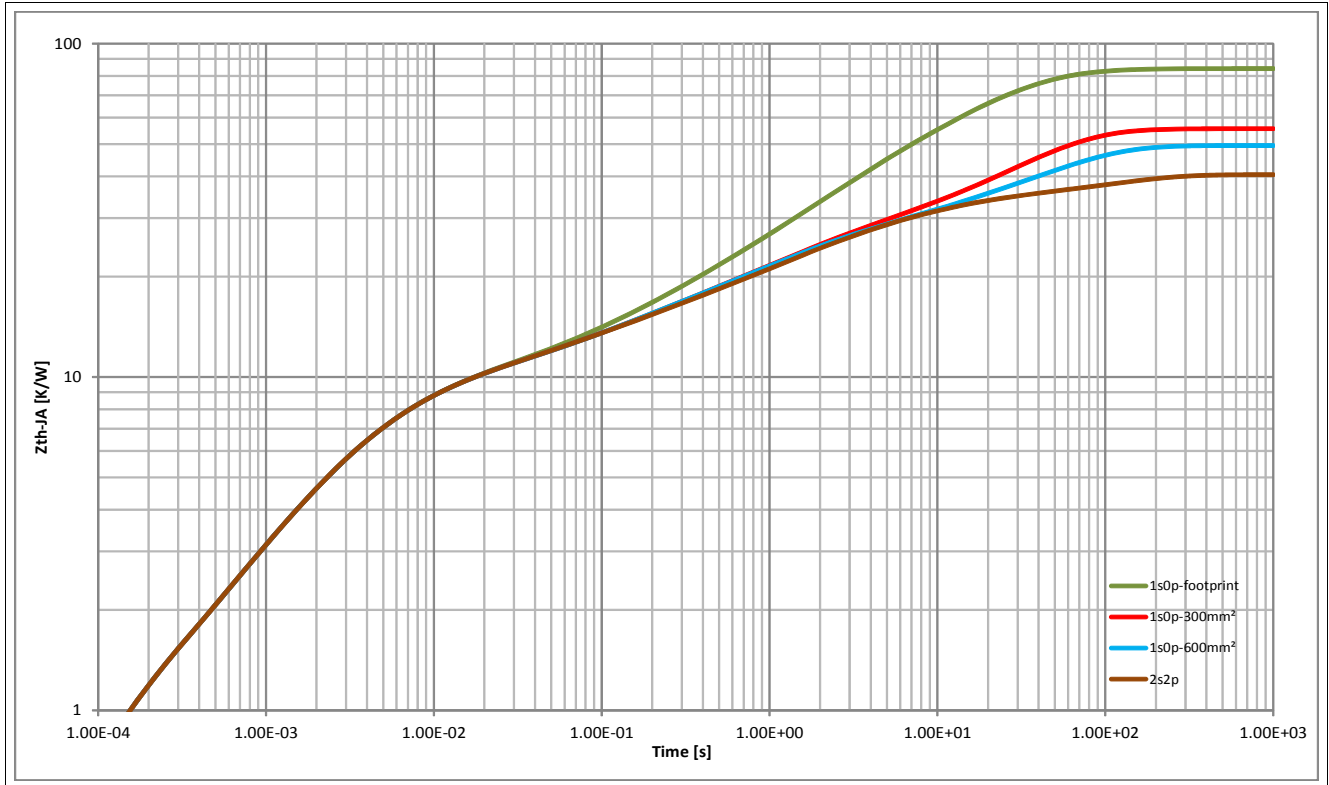

Figure 5 Typical Thermal Impedance. 2s2p PCB set up according Figure 4

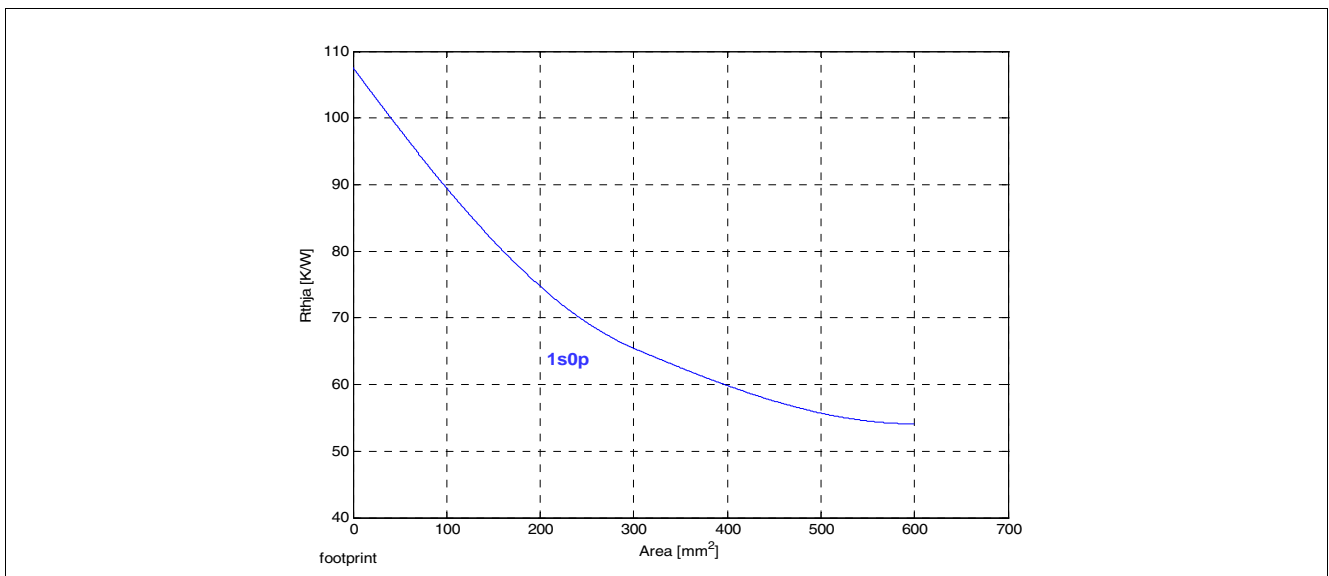

Figure 6 Typical Thermal Resistance. PCB set-up 1s0p

5 Power Stage

The power stages are built using an N-channel vertical power MOSFET (DMOS) with charge pump.

5.1 Output ON-state Resistance

The ON-state resistance $R_{DS(ON)}$ depends on the supply voltage as well as the junction temperature T_J . **Figure 7** shows the dependencies in terms of temperature and supply voltage for the typical ON-state resistance. The behavior in reverse polarity is described in **Chapter 6.4**.

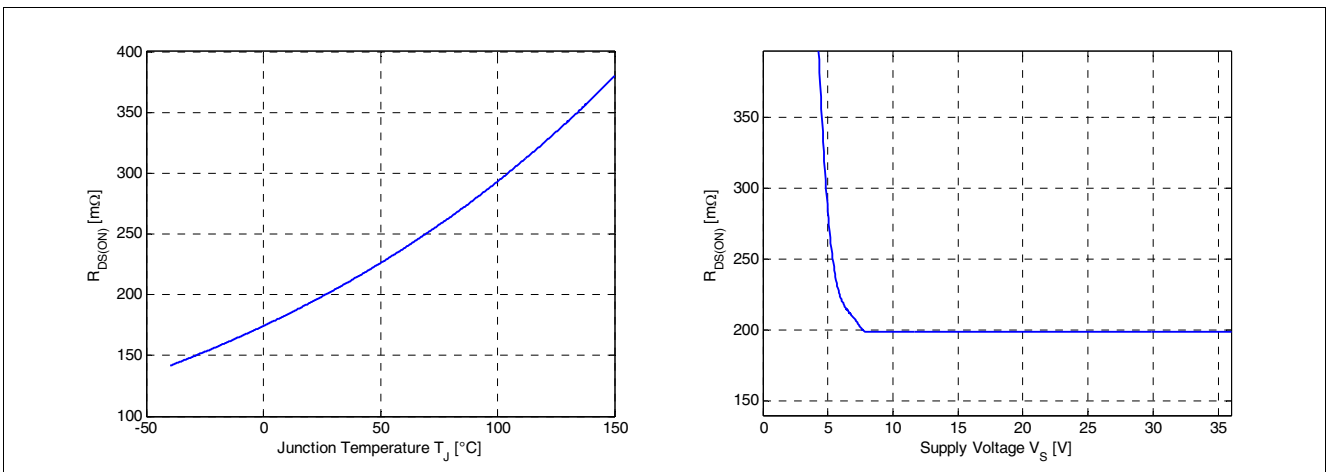

Figure 7 Typical ON-state Resistance

A high signal at the input pin (see **Chapter 8**) causes the power DMOS to switch ON with a dedicated slope, which is optimized in terms of EMC emission.

5.2 Turn ON/OFF Characteristics with Resistive Load

Figure 8 shows the typical timing when switching a resistive load.

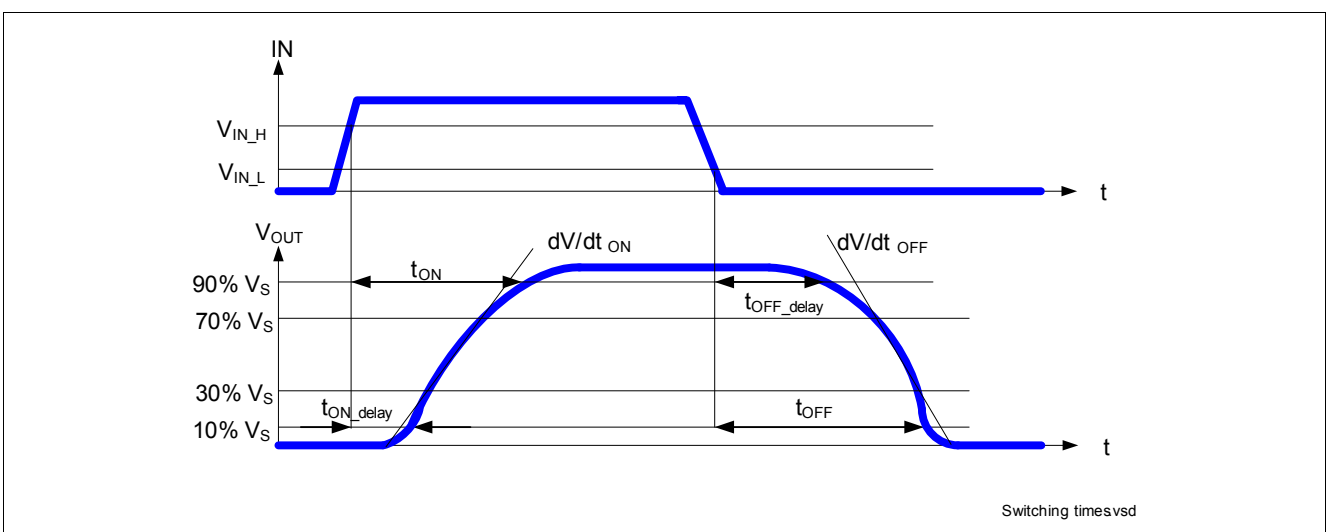

Figure 8 Switching a Resistive Load Timing

5.3 Inductive Load

5.3.1 Output Clamping

When switching OFF inductive loads with high side switches, the voltage V_{OUT} drops below ground potential, because the inductance intends to continue driving the current. To prevent the destruction of the device by avalanche due to high voltages, there is a voltage clamp mechanism $Z_{DS(AZ)}$ implemented that limits negative output voltage to a certain level ($V_S - V_{DS(AZ)}$). Please refer to **Figure 9** and **Figure 10** for details. Nevertheless, the maximum allowed load inductance is limited.

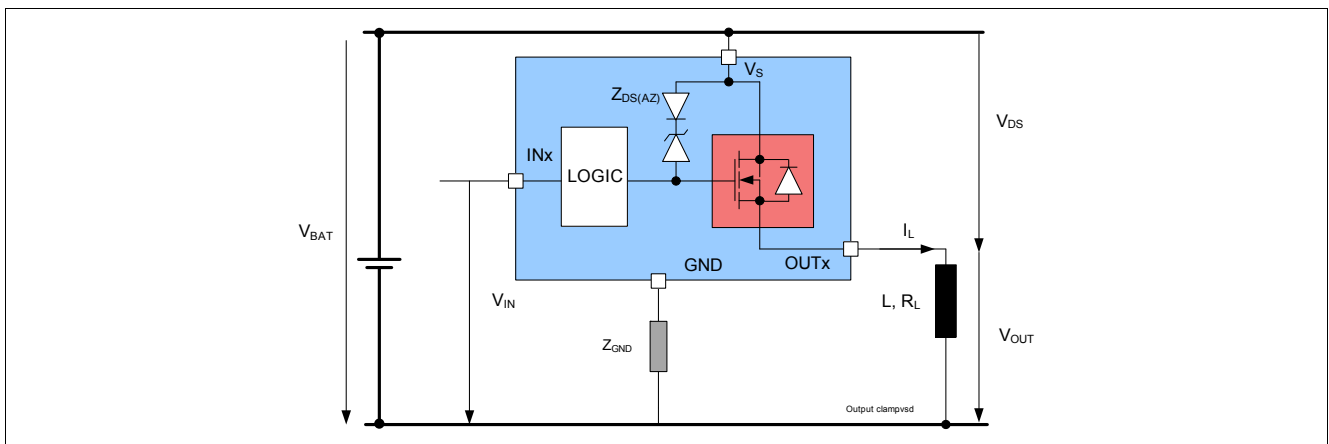

Figure 9 Output Clamp

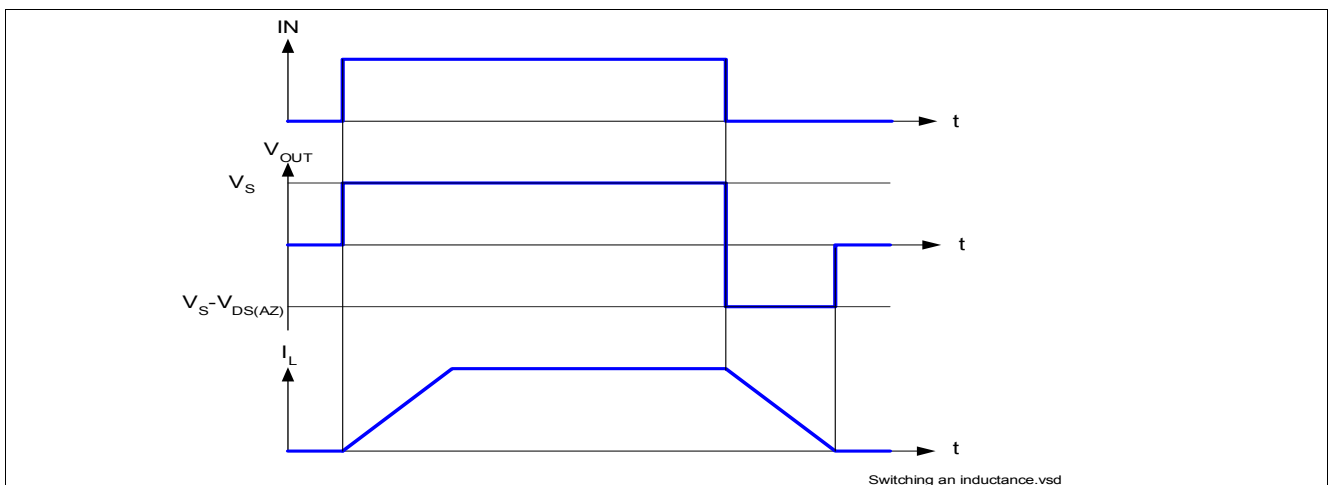

Figure 10 Switching an Inductive Load Timing

5.3.2 Maximum Load Inductance

During demagnetization of inductive loads, energy has to be dissipated in the BTS5200-4EKA. This energy can be calculated with following equation:

$$E = V_{DS(AZ)} \times \frac{L}{R_L} \times \left[\frac{V_S - V_{DS(AZ)}}{R_L} \times \ln\left(1 - \frac{R_L \times I_L}{V_S - V_{DS(AZ)}}\right) + I_L \right] \quad (1)$$

Following equation simplifies under the assumption of $R_L = 0 \Omega$.

$$E = \frac{1}{2} \times L \times I^2 \times \left(1 - \frac{V_S}{V_S - V_{DS(AZ)}}\right) \tag{2}$$

The energy, which is converted into heat, is limited by the thermal design of the component. See [Figure 11](#) for the maximum allowed energy dissipation as a function of the load current.

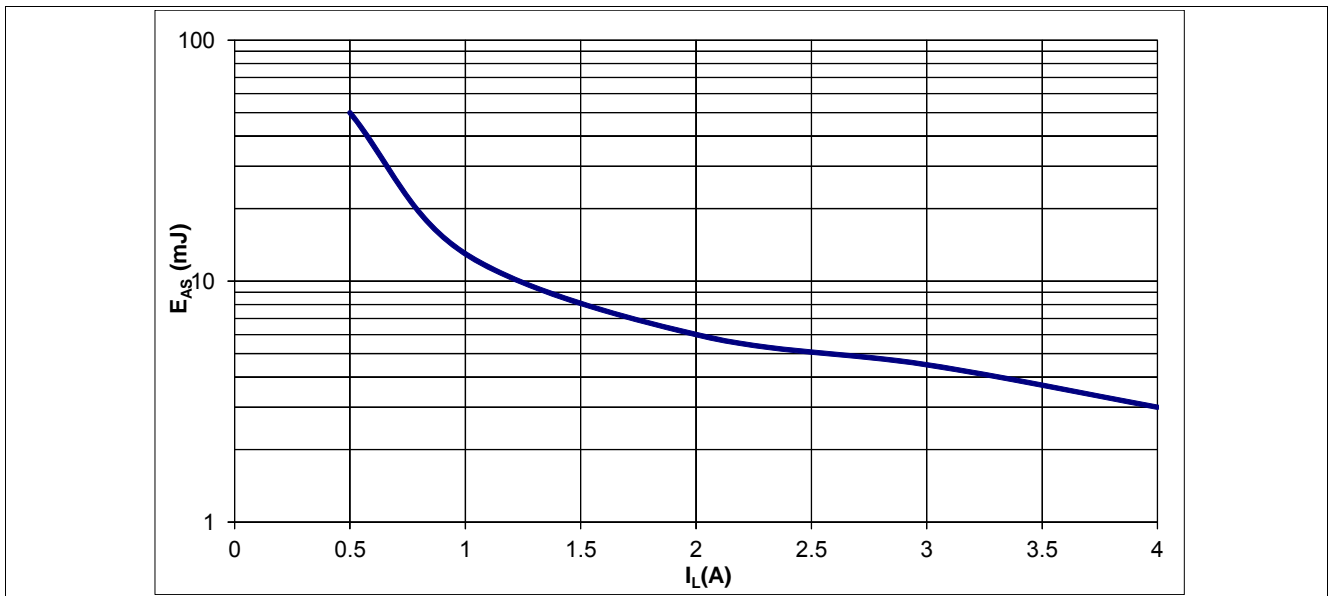

Figure 11 Maximum Energy Dissipation Single Pulse, $T_{J_START} = 150 \text{ }^\circ\text{C}$; $V_S = 13.5\text{V}$

5.4 Inverse Current Capability

In case of inverse current, meaning a voltage V_{INV} at the OUTput higher than the supply voltage V_S , a current I_{INV} will flow from output to V_S pin via the body diode of the power transistor (please refer to [Figure 12](#)). The output stage follows the state of the IN pin, except if the IN pin goes from OFF to ON during inverse. In that particular case, the output stage is kept OFF until the inverse current disappears. Nevertheless, the current I_{INV} should not be higher than $I_{L(INV)}$. If the channel is OFF, the diagnostic will detect an open load at OFF. If the affected channel is ON, the diagnostic will detect open load at ON (the overtemperature signal is inhibited). At the appearance of V_{INV} , a parasitic diagnostic can be observed. After, the diagnosis is valid and reflects the output state. At V_{INV} vanishing, the diagnosis is valid and reflects the output state. During inverse current, no protection functions are available.

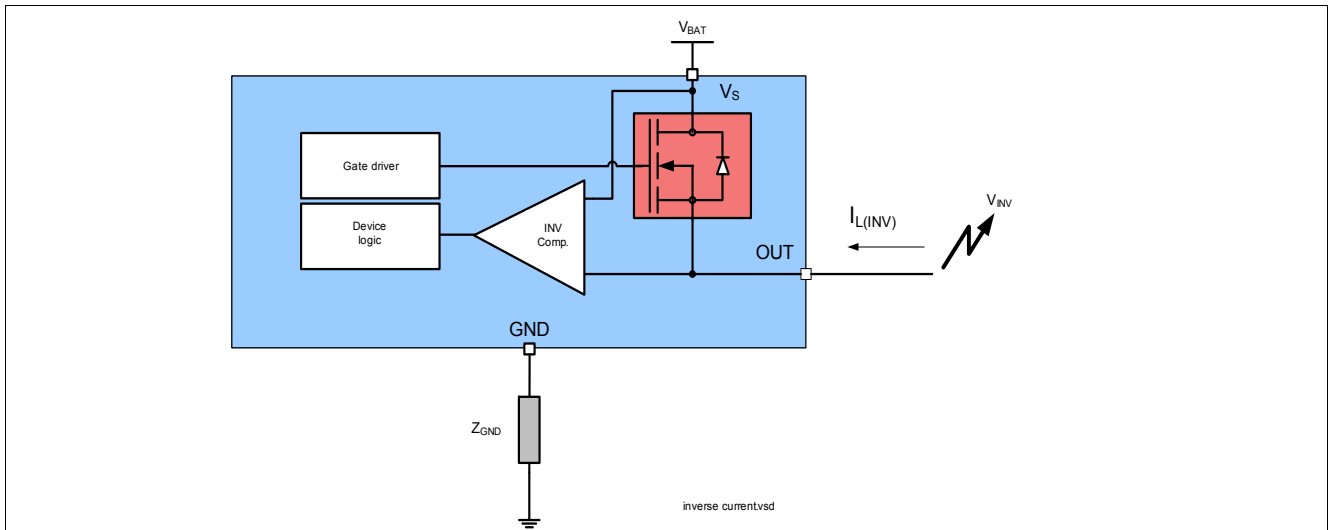

Figure 12 Inverse Current Circuitry

5.5 Electrical Characteristics Power Stage

Table 5 Electrical Characteristics: Power Stage
 $V_S = 8\text{ V to }18\text{ V}$, $T_J = -40^\circ\text{C to }150^\circ\text{C}$ (unless otherwise specified).

 Typical values are given at $V_S = 13.5\text{ V}$, $T_J = 25^\circ\text{C}$

Parameter	Symbol	Values			Unit	Note / Test Condition	Number
		Min.	Typ.	Max.			
ON-state resistance per channel	$R_{DS(ON)_150}$	300	360	400	m Ω	$I_L = I_{L4} = 0.5\text{ A}$ $V_{IN} = 4.5\text{ V}$ $T_J = 150^\circ\text{C}$ See Figure 7	P_5.5.1
ON-state resistance per channel	$R_{DS(ON)_25}$	–	200	–	m Ω	¹⁾ $T_J = 25^\circ\text{C}$	P_5.5.21
Nominal load current One channel active	$I_{L(NOM)1}$	–	1	–	A	¹⁾ $T_A = 85^\circ\text{C}$ $T_J < 150^\circ\text{C}$	P_5.5.2
Nominal load current All channels active	$I_{L(NOM)2}$	–	0.8	–	A		P_5.5.3
Output voltage drop limitation at small load currents	$V_{DS(NL)}$	–	10	25	mV	$I_L = I_{L0} = 25\text{ mA}$ See Chapter 9.3	P_5.5.4
Drain to source clamping voltage $V_{DS(AZ)} = [V_S - V_{OUT}]$	$V_{DS(AZ)}$	41	47	53	V	$I_{DS} = 20\text{ mA}$ See Figure 10 See Chapter 9.1	P_5.5.5
Output leakage current $T_J \leq 85^\circ\text{C}$ per channel	$I_{L(OFF)}$	–	0.1	0.5	μA	²⁾ V_{IN} floating $V_{OUT} = 0\text{ V}$ $T_J \leq 85^\circ\text{C}$	P_5.5.6
Output leakage current $T_J = 150^\circ\text{C}$ per channel	$I_{L(OFF)_150}$	–	–	2.5	μA	V_{IN} floating $V_{OUT} = 0\text{ V}$ $T_J = 150^\circ\text{C}$	P_5.5.8
Inverse current capability	$I_{L(NV)}$	–	0.8	–	A	¹⁾ $V_S < V_{OUTX}$	P_5.5.9
Slew rate 30% to 70% V_S	dV/dt_{ON}	0.1	0.25	0.5	V/ μs	$R_L = 25\ \Omega$ $V_S = 13.5\text{ V}$	P_5.5.11
Slew rate 70% to 30% V_S	$-dV/dt_{OFF}$	0.1	0.25	0.5	V/ μs	See Figure 8 See Chapter 9.1	P_5.5.12
Slew rate matching $dV/dt_{ON} - dV/dt_{OFF}$	$\Delta dV/dt$	-0.15	0	0.15	V/ μs		P_5.5.13
Turn-ON time to $V_{OUT} = 90\%$ V_S	t_{ON}	30	90	230	μs		P_5.5.14
Turn-OFF time to $V_{OUT} = 10\%$ V_S	t_{OFF}	30	90	230	μs		P_5.5.15
Turn-ON / OFF matching $t_{OFF} - t_{ON}$	Δt_{SW}	-50	5	50	μs		P_5.5.16
Turn-ON time to $V_{OUT} = 10\%$ V_S	t_{ON_delay}	10	35	100	μs		P_5.5.17
Turn-OFF time to $V_{OUT} = 90\%$ V_S	t_{OFF_delay}	10	35	100	μs		P_5.5.18

Table 5 Electrical Characteristics: Power Stage (cont'd)

$V_S = 8\text{ V to }18\text{ V}$, $T_J = -40^\circ\text{C to }150^\circ\text{C}$ (unless otherwise specified).
 Typical values are given at $V_S = 13.5\text{ V}$, $T_J = 25^\circ\text{C}$

Parameter	Symbol	Values			Unit	Note / Test Condition	Number
		Min.	Typ.	Max.			
Switch ON energy	E_{ON}	–	210	–	μJ	¹⁾ $R_L = 25\ \Omega$ $V_{OUT} = 90\% V_S$ $V_S = 18\text{ V}$ See Chapter 9.1	P_5.5.19
Switch OFF energy	E_{OFF}	–	140	–	μJ	¹⁾ $R_L = 25\ \Omega$ $V_{OUT} = 10\% V_S$ $V_S = 18\text{ V}$ See Chapter 9.1	P_5.5.20

- 1) Not subject to production test, specified by design.
- 2) Test at $T_J = -40^\circ\text{C}$ only

6 Protection Functions

The device provides integrated protection functions. These functions are designed to prevent the destruction of the IC from fault conditions described in the data sheet. Fault conditions are considered as “outside” normal operating range. Protection functions are designed for neither continuous nor repetitive operation.

6.1 Loss of Ground Protection

In case of loss of the module ground and the load remains connected to ground, the device protects itself by automatically turning OFF (when it was previously ON) or remains OFF, regardless of the voltage applied on IN pins.

In case of loss of device ground, it's recommended to use input resistors between the microcontroller and the BTS5200-4EKA to ensure switching OFF of channels.

In case of loss of module or device ground, a current ($I_{OUT(GND)}$) can flow out of the DMOS. **Figure 13** sketches the situation.

Z_{GND} is recommended to be a diode in parallel to a resistor (1 k Ω).

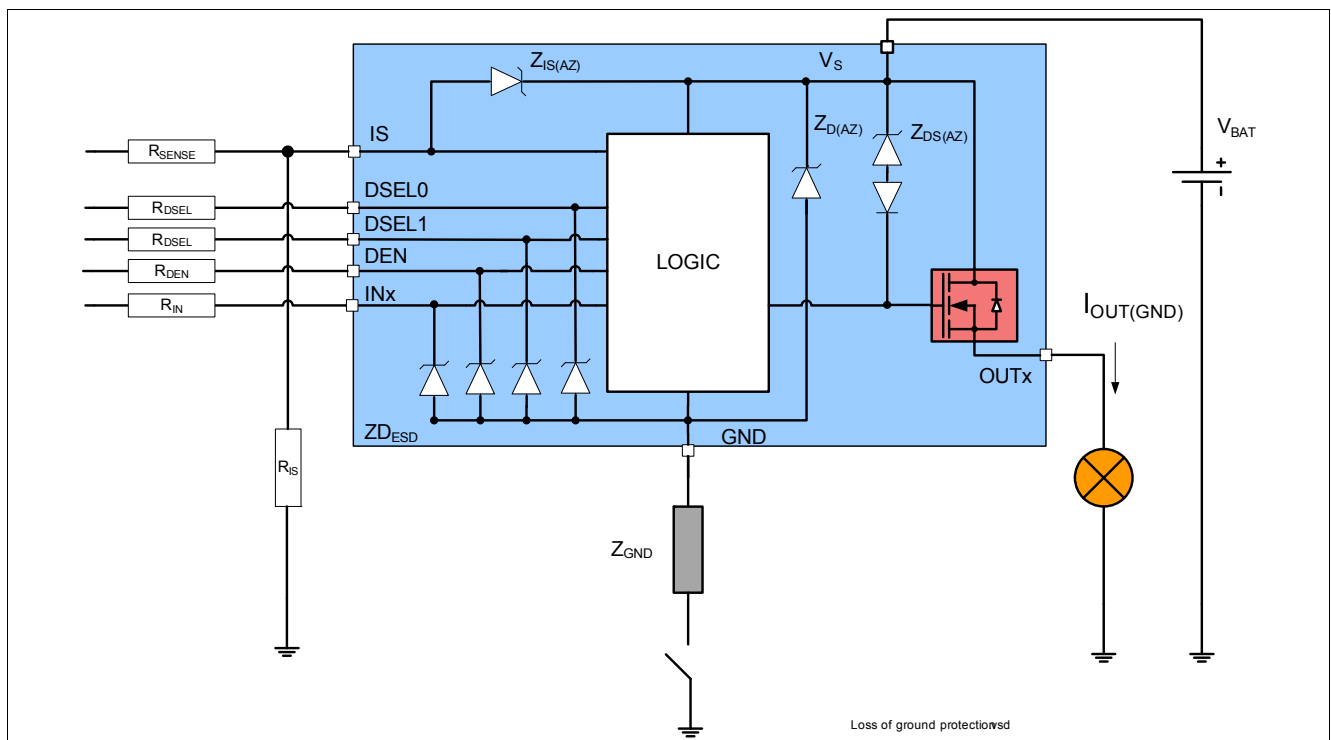

Figure 13 Loss of Ground Protection with External Components

6.2 Undervoltage Protection

Between $V_{S(UV)}$ and $V_{S(OP)}$, the undervoltage mechanism is triggered. $V_{S(OP)}$ represents the minimum voltage where the switching ON and OFF can take place. $V_{S(UV)}$ represents the minimum voltage the switch can hold ON. If the supply voltage is below the undervoltage mechanism $V_{S(UV)}$, the device is OFF (turns OFF). As soon as the supply voltage is above the undervoltage mechanism $V_{S(OP)}$, then the device can be switched ON. When the switch is ON, protection functions are operational. Nevertheless, the diagnosis is not guaranteed until V_S is in the V_{NOM} range. **Figure 14** sketches the undervoltage mechanism.

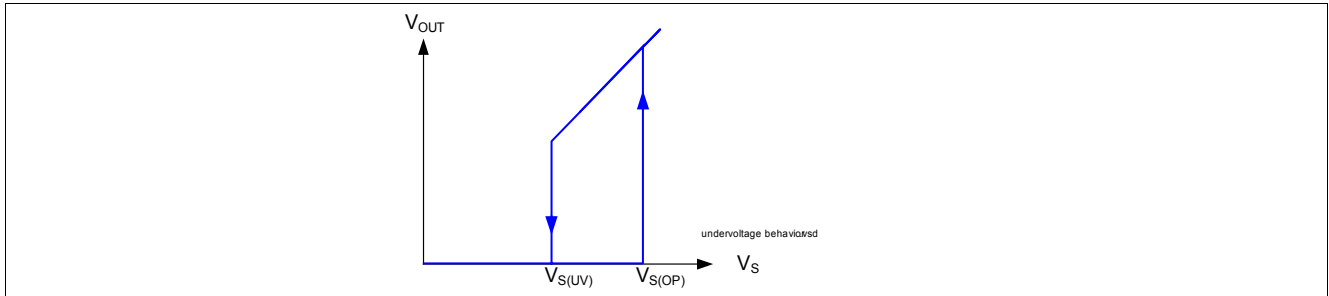

Figure 14 Undervoltage Behavior

6.3 Overvoltage Protection

There is an integrated clamp mechanism for overvoltage protection ($Z_{D(AZ)}$). To guarantee this mechanism operates properly in the application, the current in the Zener diode has to be limited by a ground resistor. **Figure 15** shows a typical application to withstand overvoltage issues. In case of supply voltage higher than $V_{S(AZ)}$, the power transistor switches ON and the voltage across the logic section is clamped. As a result, the internal ground potential rises to $V_S - V_{S(AZ)}$. Due to the ESD Zener diodes, the potential at pin INx, DSELx, and DEN rises almost to that potential, depending on the impedance of the connected circuitry. In the case the device was ON, prior to overvoltage, the BTS5200-4EKA remains ON. In the case the BTS5200-4EKA was OFF, prior to overvoltage, the power transistor can be activated. In the case the supply voltage is in above $V_{BAT(SC)}$ and below $V_{DS(AZ)}$, the output transistor is still operational and follows the input. If at least one channel is in the ON state, parameters are no longer guaranteed and lifetime is reduced compared to the nominal supply voltage range. This especially impacts the short circuit robustness, as well as the maximum energy E_{AS} capability. Z_{GND} with a resistor (27 Ω) in series to the diode will offer better results.

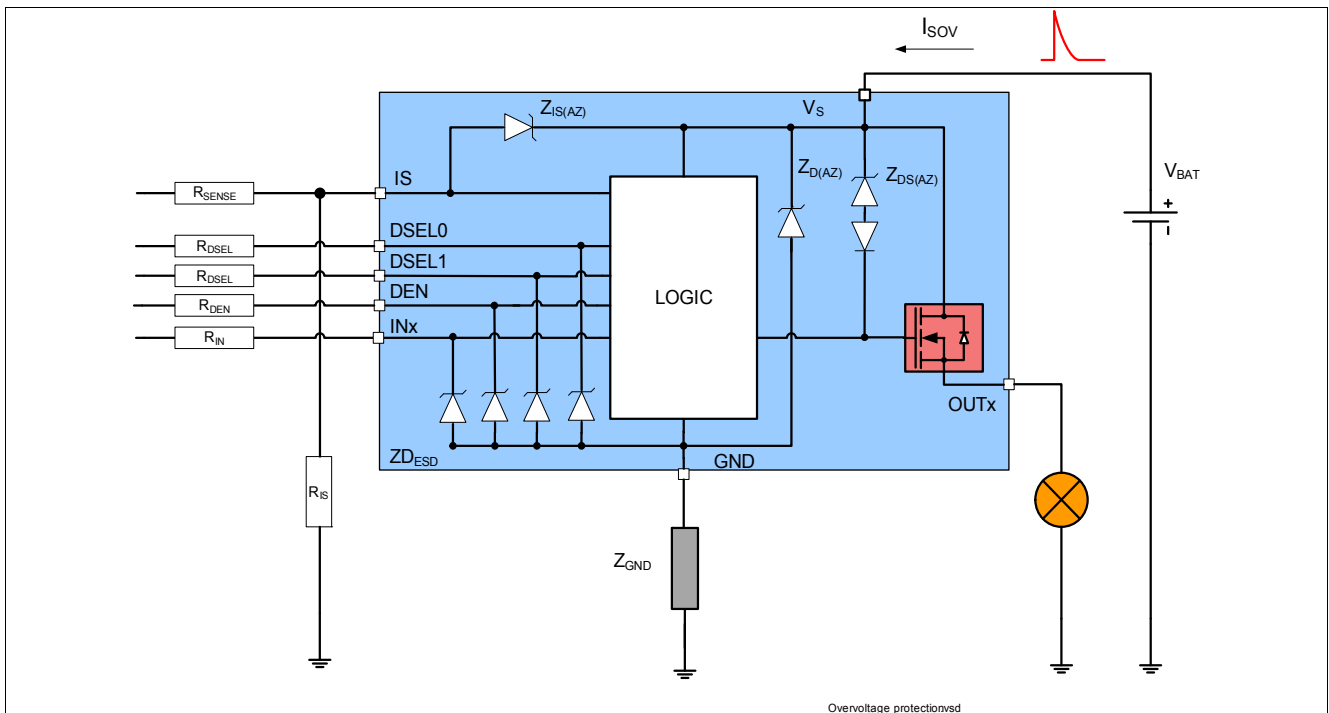

Figure 15 Overvoltage Protection with External Components

6.4 Reverse Polarity Protection

In case of reverse polarity, the intrinsic body diodes of the power DMOS causes power dissipation. The current in this intrinsic body diode is limited by the load itself. Additionally, the current into the ground path and the logic pins has to be limited to the maximum current described in Chapter 4.1 with an external resistor. Figure 16 shows a typical application. R_{GND} resistor is used to limit the current in the Zener protection of the device. Resistors R_{DSEL} , R_{DEN} , and R_{IN} are used to limit the current in the logic of the device and in the ESD protection stage. R_{SENSE} is used to limit the current in the sense transistor which behaves as a diode. The recommended value for $R_{DEN} = R_{DSEL} = R_{IN} = R_{SENSE} = 4.7\text{ k}\Omega$. Z_{GND} is recommended to be a $1\text{ k}\Omega$ resistor in parallel to a diode. During reverse polarity, no protection functions are available.

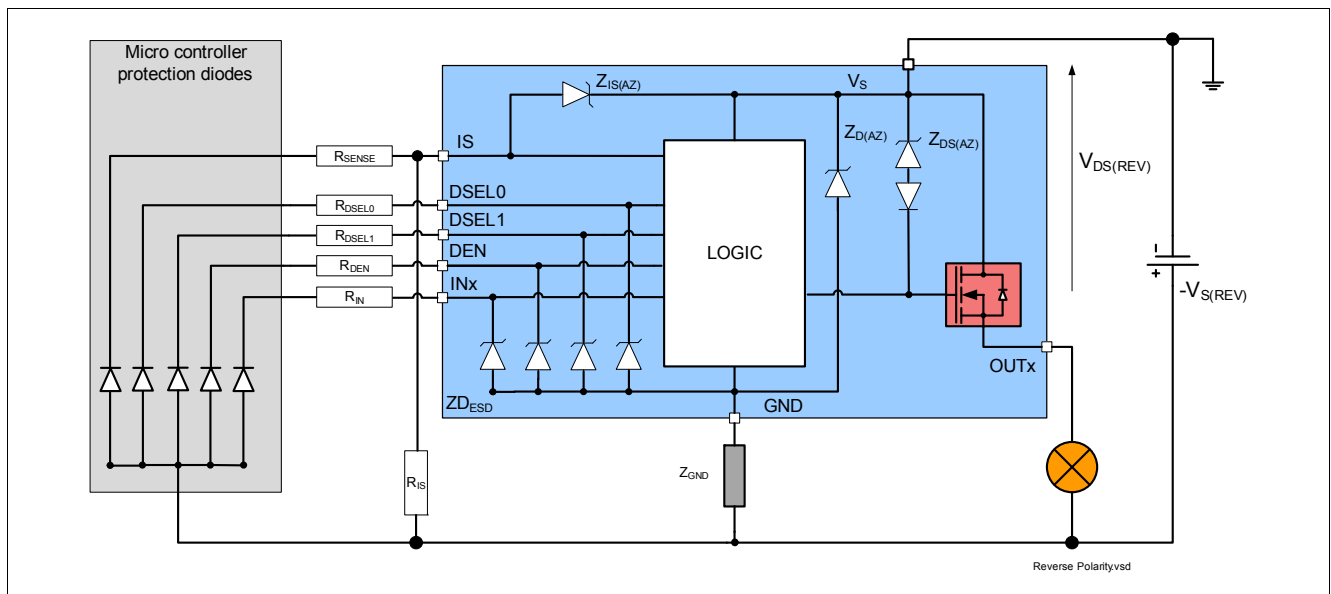

Figure 16 Reverse Polarity Protection with External Components

6.5 Overload Protection

In case of overload, such as high inrush of cold lamp filament, or short circuit to ground, the BTS5200-4EKA offers several protection mechanisms.

6.5.1 Current Limitation

At first step, the instantaneous power in the switch is maintained at a safe value by limiting the current to the maximum current allowed in the switch $I_{L(SC)}$. During this time, the DMOS temperature is increasing, which affects the current flowing in the DMOS. The current limitation value is V_{DS} dependent. Figure 17 shows the behavior of the current limitation as a function of the drain to source voltage.

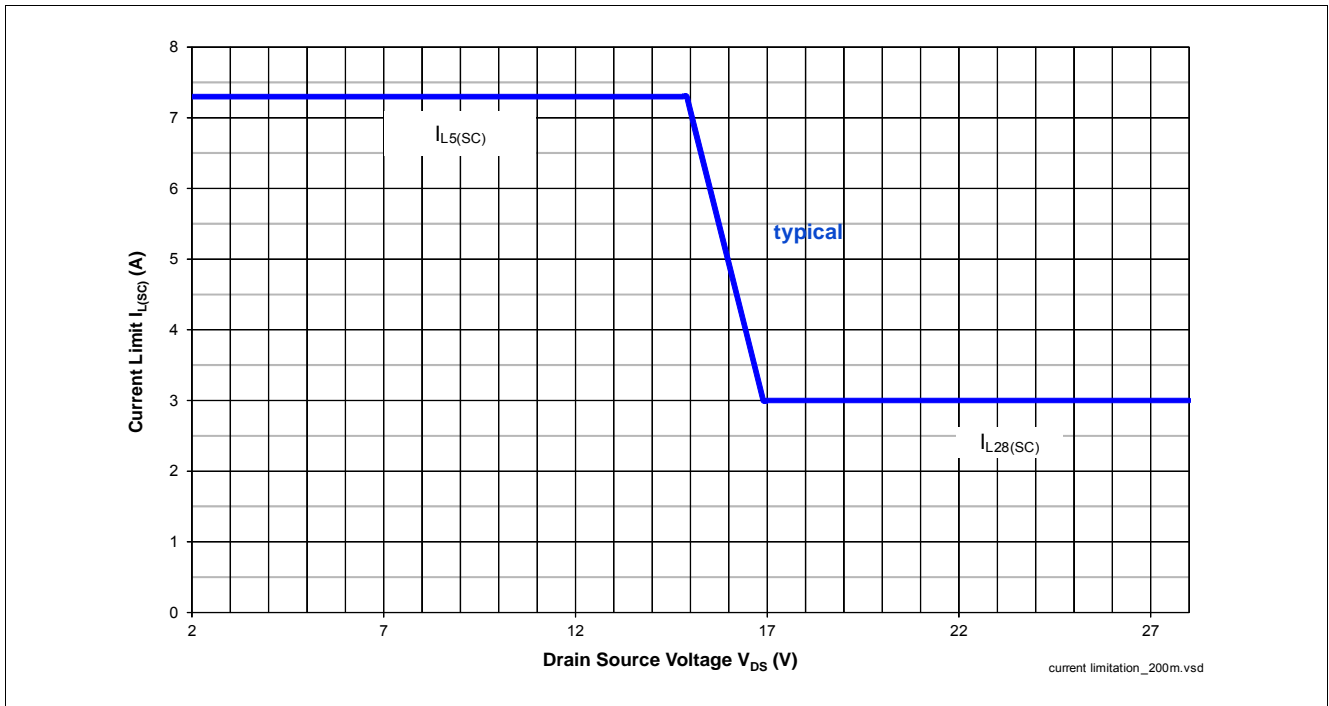

Figure 17 Current Limitation (typical behavior)

6.5.2 Temperature Limitation in the Power DMOS

Each channel incorporates an absolute ($T_{J(SC)}$) temperature sensor and a switch OFF timer that is started by an overcurrent event. The activation of these protection mechanisms will cause an overheated channel to switch OFF to prevent destruction. A temperature limitation switch OFF latches the output until the temperature has reached an acceptable value. [Figure 18](#) gives a sketch of the situation.

A retry strategy is implemented such that when the DMOS temperature has cooled down enough, the switch is switched ON again, if the IN pin signal is still high (restart behavior).

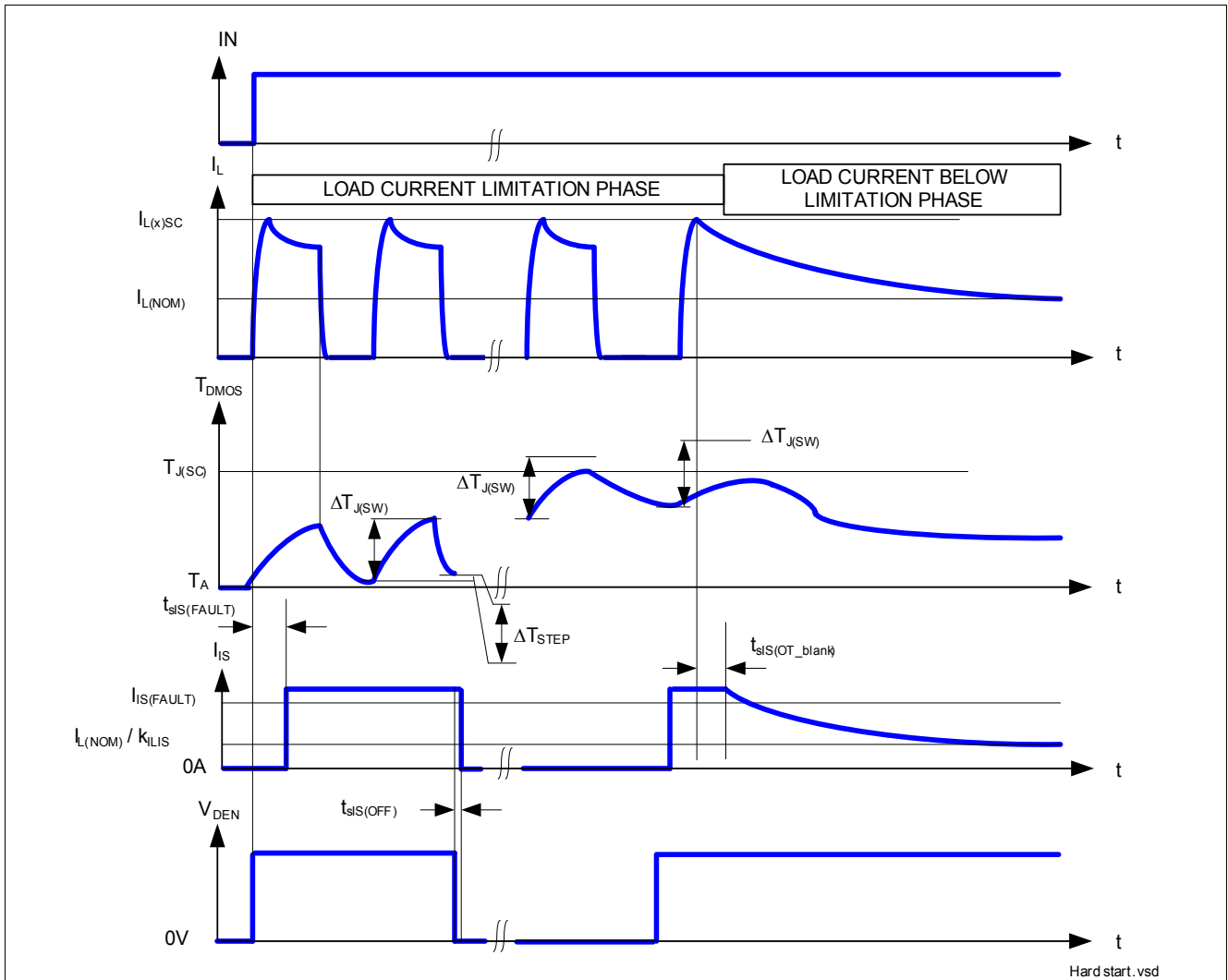

Figure 18 Overload Protection

Note: For better understanding, the time scale is not linear. The real timing of this drawing is application dependant and cannot be described.

6.5.3 Short Circuit Appearance with Channels in Parallel

The four channels are not synchronised in the restart event. When the channels are in temperature limitation, the channel which has cooled down the fastest doesn't wait for the other to be cooled down as well to restart. Thus, it is not recommended to use the device with channels in parallel.

6.6 Electrical Characteristics for the Protection Functions

Table 6 Electrical Characteristics: Protection
 $V_S = 8\text{ V to }18\text{ V}$, $T_J = -40^\circ\text{C to }150^\circ\text{C}$ (unless otherwise specified).

 Typical values are given at $V_S = 13.5\text{ V}$, $T_J = 25^\circ\text{C}$

Parameter	Symbol	Values			Unit	Note / Test Condition	Number
		Min.	Typ.	Max.			
Loss of Ground							
Output leakage current while GND disconnected	$I_{\text{OUT(GND)}}$	–	0.1	–	mA	¹⁾²⁾ $V_S = 28\text{ V}$ See Figure 13	P_6.6.1
Reverse Polarity							
Drain source diode voltage during reverse polarity	$V_{\text{DS(REV)}}$	200	650	700	mV	³⁾ $I_L = -0.5\text{ A}$ $T_J = 150^\circ\text{C}$ See Figure 16	P_6.6.2
Overvoltage							
Overvoltage protection	$V_{\text{S(AZ)}}$	41	47	53	V	$I_{\text{SOV}} = 5\text{ mA}$ See Figure 15	P_6.6.3
Overload Condition							
Load current limitation	$I_{\text{L5(SC)}}$	5.6	7.3	9	A	⁴⁾ $V_{\text{DS}} = 5\text{ V}$ See Figure 17 and Chapter 9.3	P_6.6.4
Load current limitation	$I_{\text{L28(SC)}}$	–	3	–	A	²⁾ $V_{\text{DS}} = 28\text{ V}$ See Figure 17 and Chapter 9.3	P_6.6.7
Short circuit average current after several minutes of thermal toggling	$I_{\text{L(RMS)}}$	–	1	–	A	²⁾ $V_{\text{IN}} = 4.5\text{ V}$ $R_{\text{SHORT}} = 100\text{ m}\Omega$ $L_{\text{SHORT}} = 5\text{ }\mu\text{H}$	P_6.6.12
Thermal shutdown temperature	$T_{\text{J(SC)}}$	150	170	200	$^\circ\text{C}$	^{3) 5)} See Figure 18	P_6.6.10
Thermal shutdown hysteresis	$\Delta T_{\text{J(SC)}}$	–	20	–	K	²⁾ See Figure 18	P_6.6.11

 1) All pins are disconnected except V_S and OUT.

2) Not Subject to production test, specified by design

 3) Test at $T_J = +150^\circ\text{C}$ only

 4) Test at $T_J = -40^\circ\text{C}$ only

5) Functional test only

7 Diagnostic Functions

For diagnosis purpose, the BTS5200-4EKA provides a combination of digital and analog signals at pin IS. In case the diagnostic is disabled via DEN, pin IS becomes high impedance. In case DEN is activated, the sense current of the channel X is enabled/disabled via associated pins DSEL0 and DSEL1. **Table 7** gives the truth table.

Table 7 Diagnostic Truth Table

DEN	DSEL1	DSEL0	IS0	IS1	IS2	IS3
0	don't care	don't care	Z	Z	Z	Z
1	0	0	IIS0	0	0	0
1	0	1	0	IIS1	0	0
1	1	0	0	0	IIS2	0
1	1	1	0	0	0	IIS3

7.1 IS Pin

The BTS5200-4EKA provides a sense signal called I_{IS} at pin IS. As long as no “hard” failure mode occurs (short circuit to GND / current limitation / overtemperature / excessive dynamic temperature increase or open load at OFF) a proportional signal to the load current (ratio $k_{ILIS} = I_L / I_{IS}$) is provided. The complete IS pin and diagnostic mechanism is described on **Figure 19**. The accuracy of the sense current depends on temperature and load current. The sense pin multiplexes the currents $I_{IS(0)}$, $I_{IS(1)}$, $I_{IS(2)}$ and $I_{IS(3)}$ via the pins DSEL0 and DSEL1. Thanks to this multiplexing, the matching between $k_{ILISCHANNEL0}$, $k_{ILISCHANNEL1}$, $k_{ILISCHANNEL2}$ and $k_{ILISCHANNEL3}$ is optimized. Due to the ESD protection, in connection to V_S , it is not recommended to share the IS pin with other devices if these devices are using another battery feed. The consequence is that the unsupplied device would be fed via the IS pin of the supplied device.

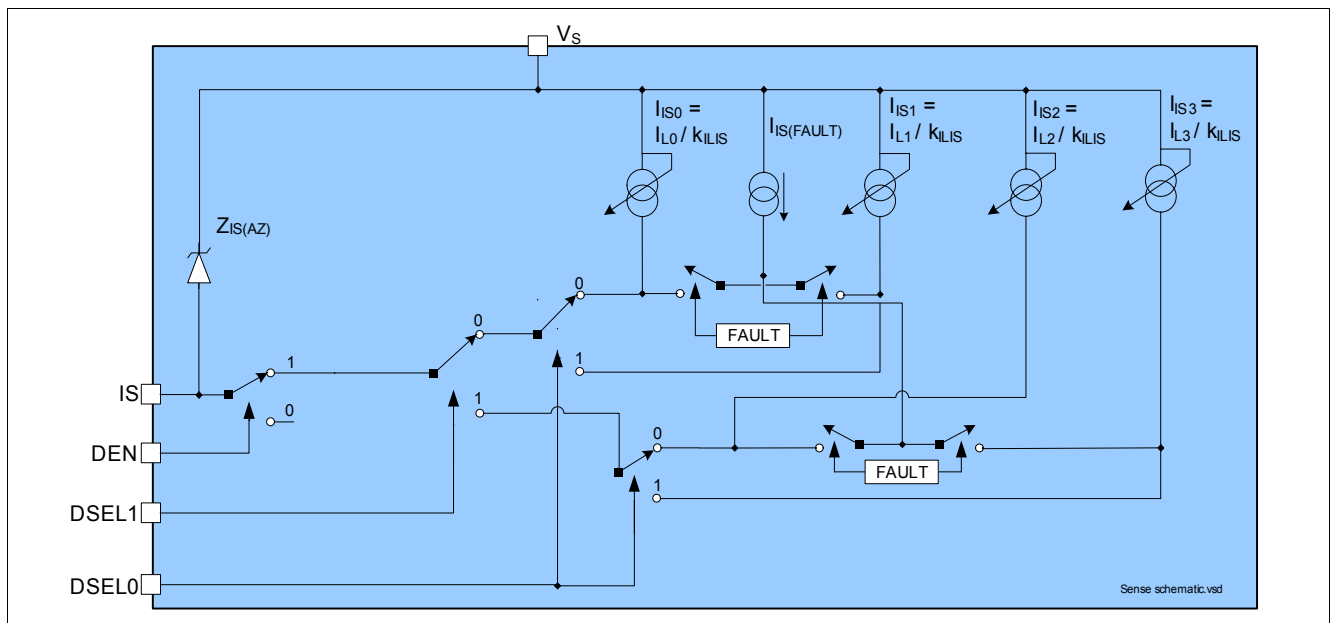

Figure 19 Diagnostic Block Diagram

7.2 SENSE Signal in Different Operating Modes

Table 8 gives a quick reference for the state of the IS pin during device operation.

Table 8 Sense Signal, Function of Operation Mode

Operation Mode	Input level Channel X	DEN ¹⁾	Output Level	Diagnostic Output		
Normal operation	OFF	H	Z	Z		
Short circuit to GND			~ GND	Z		
Overtemperature			Z	Z		
Short circuit to V_S			V_S	$I_{IS(FAULT)}$		
Open Load			$< V_{OL(OFF)}$ $> V_{OL(OFF)}^{2)}$	Z $I_{IS(FAULT)}$		
Inverse current			~ V_{INV}	$I_{IS(FAULT)}$		
Normal operation			ON	L	~ V_S	$I_{IS} = I_L / k_{ILIS}$
Current limitation	$< V_S$	$I_{IS(FAULT)}$				
Short circuit to GND	~ GND	$I_{IS(FAULT)}$				
Overtemperature $T_{J(SW)}$ event	Z	$I_{IS(FAULT)}$				
Short circuit to V_S	V_S	$I_{IS} < I_L / k_{ILIS}$				
Open Load	~ $V_S^{3)}$	$I_{IS} < I_{IS(OL)}$				
Inverse current	~ V_{INV}	$I_{IS} < I_{IS(OL)}^{4)}$				
Underload	~ $V_S^{5)}$	$I_{S(OL)} < I_{IS} < I_L / k_{ILIS}$				
Don't care	Don't care	L			Don't care	Z

1) The table doesn't indicate but it is assumed that the appropriate channel is selected via the DSEL pins.

2) Stable with additional pull-up resistor.

3) The output current has to be smaller than $I_{L(OL)}$.

4) After maximum t_{INV} .

5) The output current has to be higher than $I_{L(OL)}$.

7.3 SENSE Signal in the Nominal Current Range

Figure 20 and **Figure 21** show the current sense as a function of the load current in the power DMOS. Usually, a pull-down resistor R_{IS} is connected to the current sense IS pin. This resistor has to be higher than 560 Ω to limit the power losses in the sense circuitry. A typical value is 1.2 k Ω . The blue curve represents the ideal sense current, assuming an ideal k_{ILIS} factor value. The red curves shows the accuracy the device provides across full temperature range at a defined current.

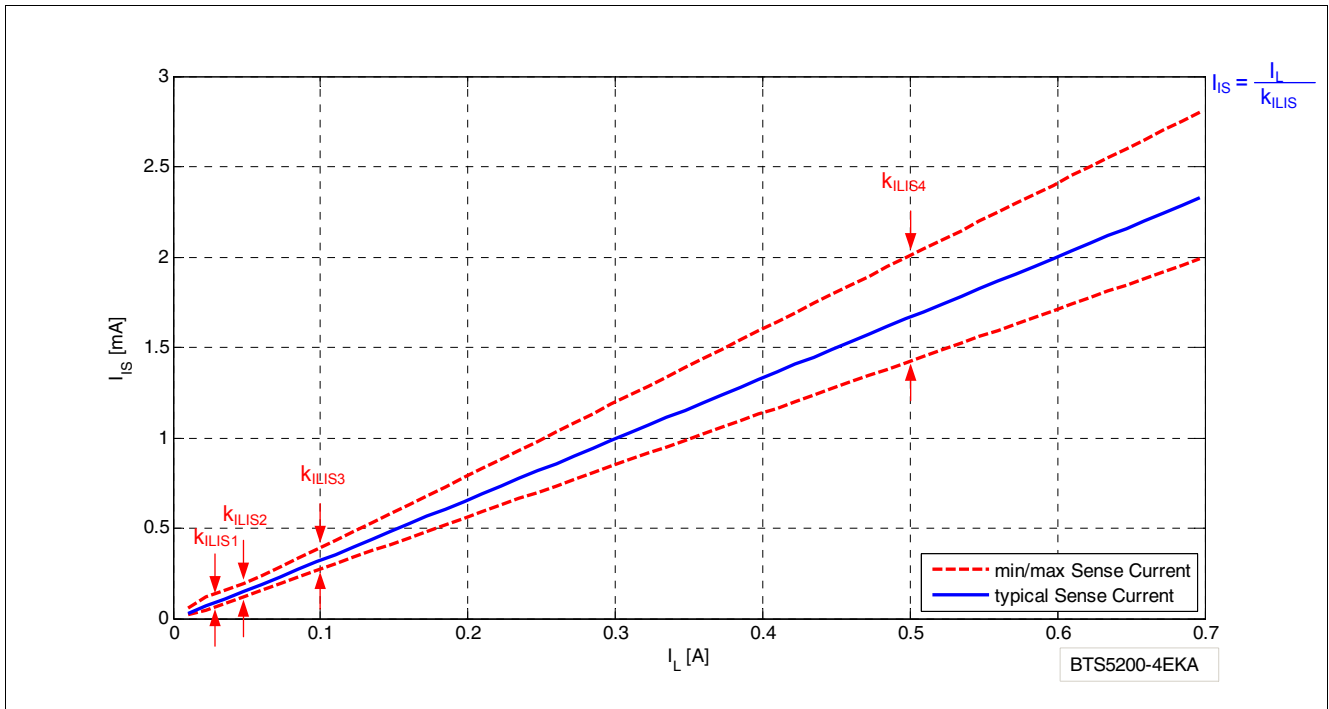

Figure 20 Current Sense for Nominal Load

7.3.1 SENSE Signal Variation as a Function of Temperature and Load Current

In some applications a better accuracy is required at smaller currents. To achieve this accuracy requirement, a calibration on the application is possible. To avoid multiple calibration points at different load and temperature conditions, the BTS5200-4EKA allows limited derating of the k_{ILIS} value, at a given point (I_{L3} ; $T_J = +25\text{ °C}$). This derating is described by the parameter Δk_{ILIS} . Figure 21 shows the behavior of the sense current, assuming one calibration point at nominal load at +25 °C.

The blue line indicates the ideal k_{ILIS} ratio.

The green lines indicate the derating on the parameter across temperature and voltage, assuming one calibration point at nominal temperature and nominal battery voltage.

The red lines indicate the k_{ILIS} accuracy without calibration.

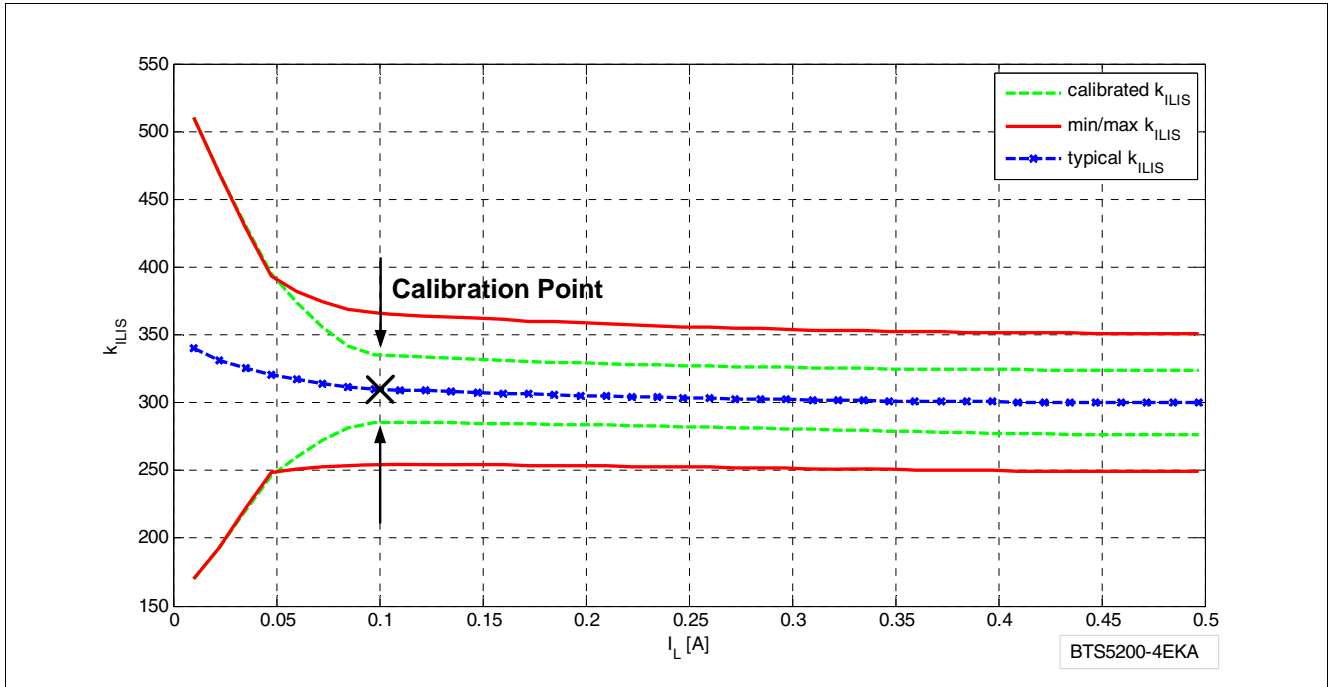

Figure 21 Improved Current Sense Accuracy with One Calibration Point

7.3.2 SENSE Signal Timing

Figure 22 shows the timing during settling and disabling of the SENSE.

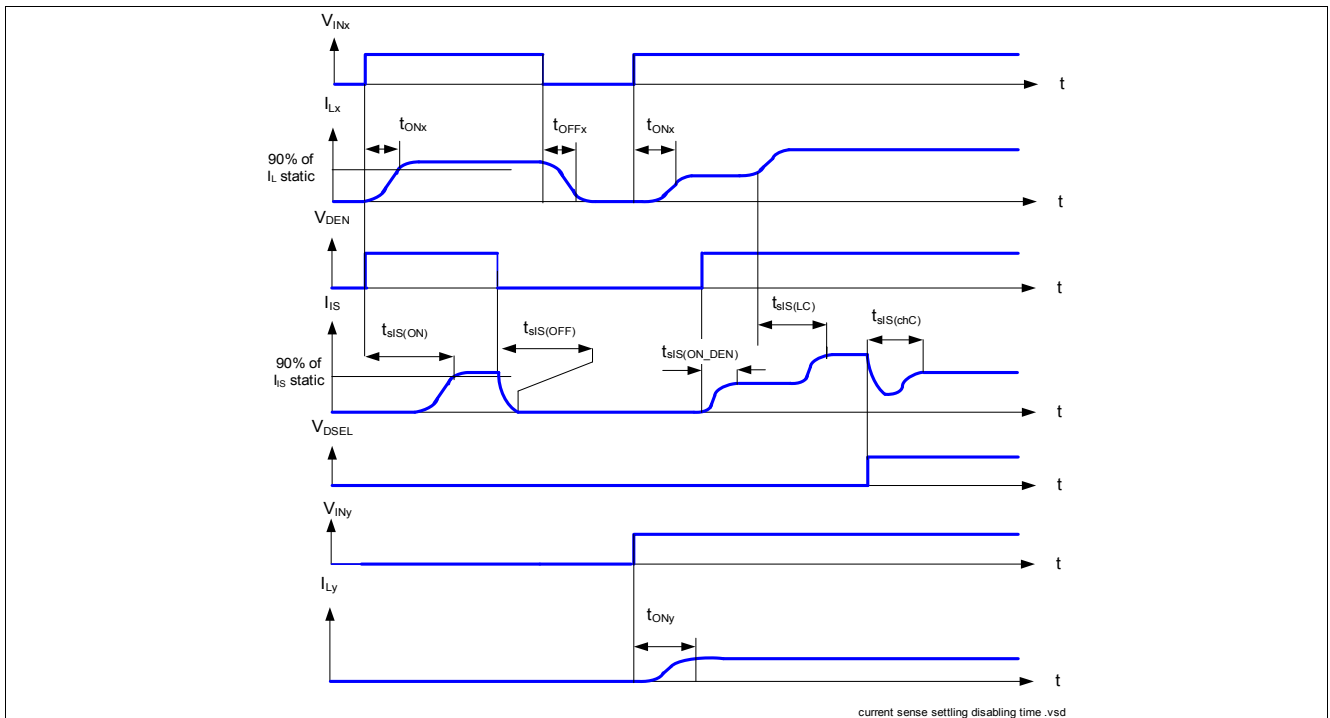

Figure 22 Current Sense Settling / Disabling Timing

7.3.3 SENSE Signal in Open Load

7.3.3.1 Open Load in ON Diagnostic

If the channel is ON, a leakage current can still flow through an open load, for example due to humidity. The parameter $I_{L(OL)}$ gives the threshold of recognition for this leakage current. If the current I_L flowing out the power DMOS is below this value, the device recognizes a failure, if the DEN (and DSEL) is selected. In that case, the SENSE current is below $I_{IS(OL)}$. Otherwise, the minimum SENSE current is given above parameter $I_{IS(OL)}$. **Figure 23** shows the SENSE current behavior in this area. The red curve shows a typical product curve. The blue curve shows the ideal current sense.

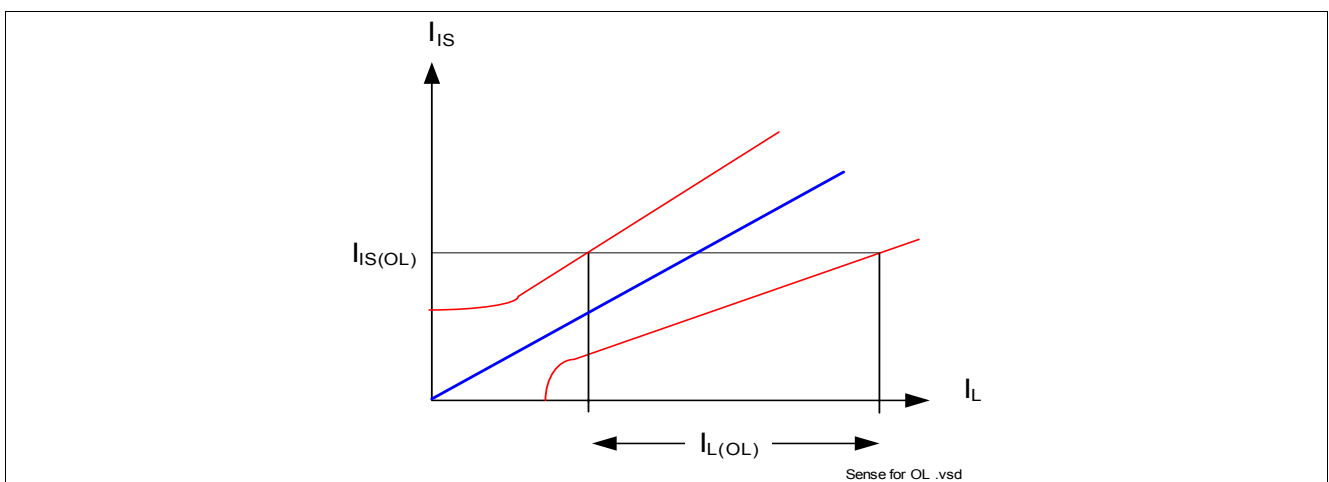

Figure 23 Current Sense Ratio for Low Currents

7.3.3.2 Open Load in OFF Diagnostic

For open load diagnosis in OFF-state, an external output pull-up resistor (R_{OL}) is recommended. For the calculation of pull-up resistor value, the leakage currents and the open load threshold voltage $V_{OL(OFF)}$ have to be taken into account. **Figure 24** gives a sketch of the situation. $I_{leakage}$ defines the leakage current in the complete system, including $I_{L(OFF)}$ (see **Chapter 5.5**) and external leakages, e.g. due to humidity, corrosion, etc... in the application.

To reduce the stand-by current of the system, an open load resistor switch S_{OL} is recommended. If the channel x is OFF, the output is no longer pulled down by the load and V_{OUT} voltage rises to nearly V_S . This is recognized by the device as an open load. The voltage threshold is given by $V_{OL(OFF)}$. In that case, the SENSE signal is switched to the $I_{IS(FAULT)}$.

An additional R_{PD} resistor can be used to pull V_{OUT} to 0V. Otherwise, the OUT pin is floating. This resistor can be used as well for short circuit to battery detection, see **Chapter 7.3.4**.

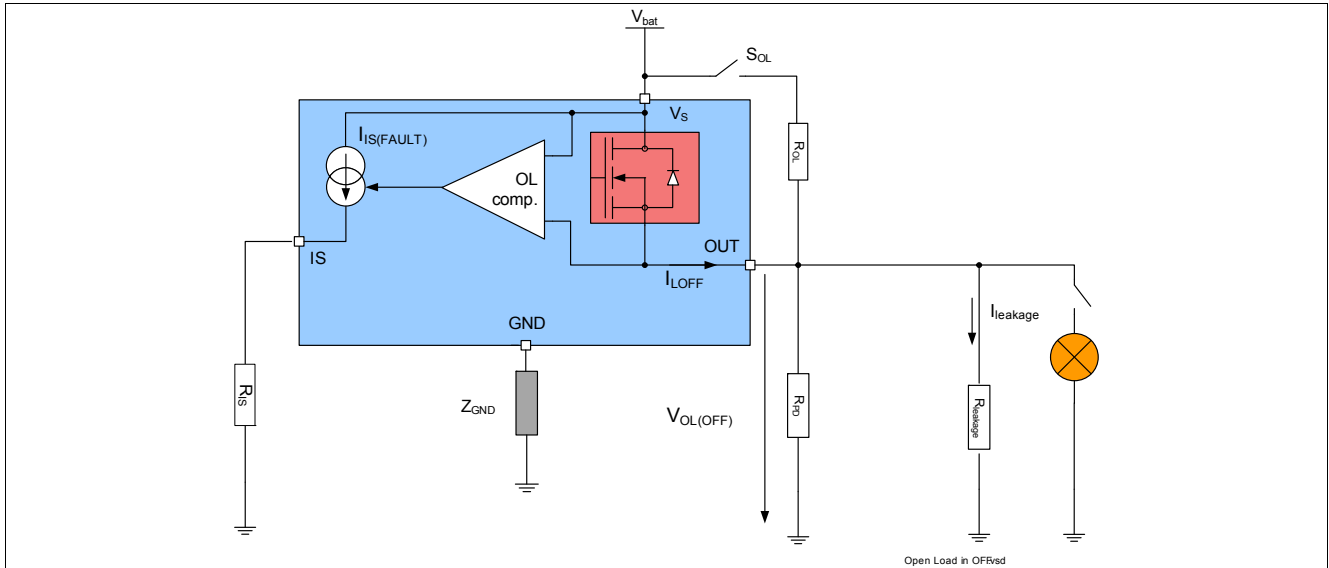

Figure 24 Open Load Detection in OFF Electrical Equivalent Circuit

7.3.3.3 Open Load Diagnostic Timing

Figure 25 shows the timing during either Open Load in ON or OFF condition when the DEN pin is HIGH. Please note that a delay $t_{sIS(FAULT_OL_OFF)}$ has to be respected after the falling edge of the input, when applying an open load in OFF diagnosis request, otherwise the diagnosis can be wrong.

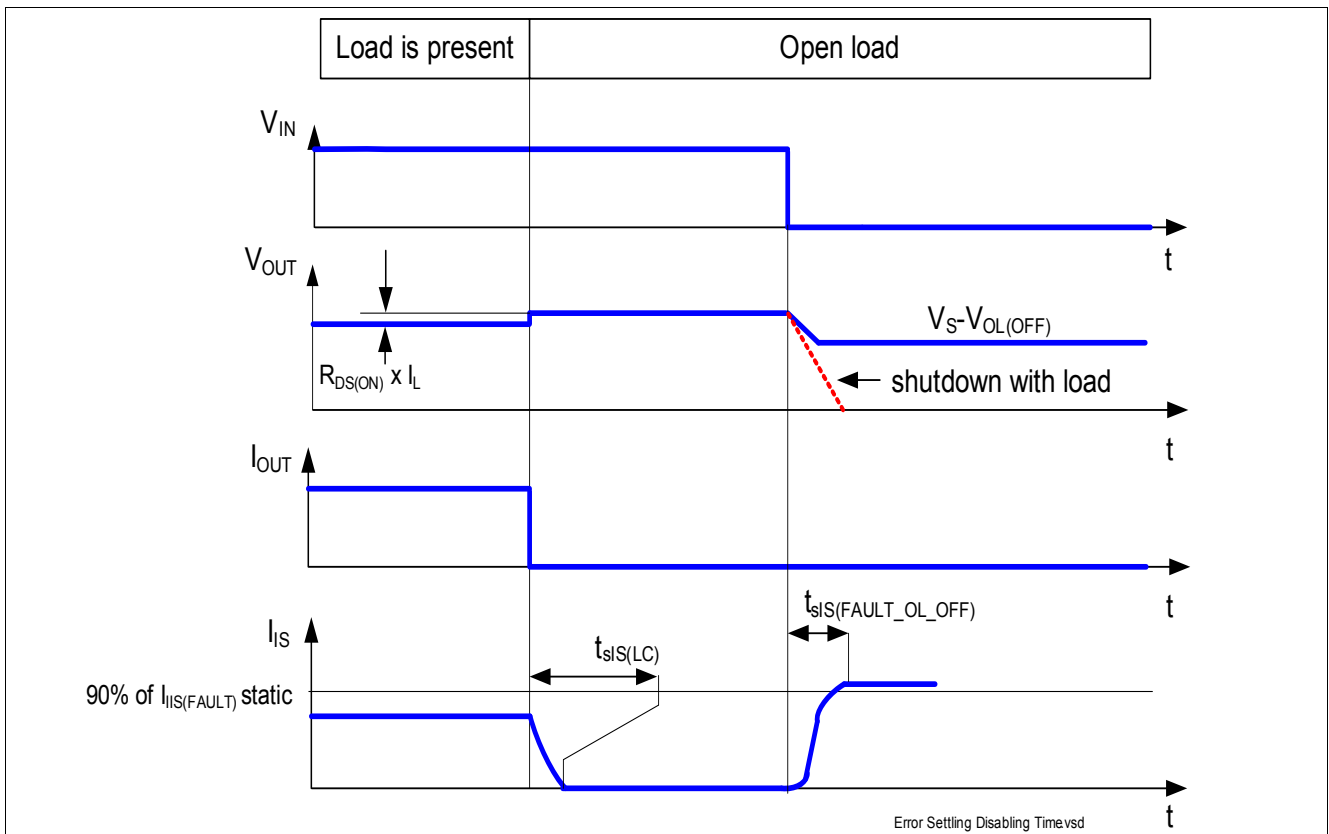

Figure 25 Sense Signal in Open Load Timing

7.3.4 SENSE Signal in Short Circuit to V_S

In case of a short circuit between the OUTput-pin and the V_S pin, all or portion (depending on the short circuit impedance) of the load current will flow through the short circuit. As a result, a lower current compared to the normal operation will flow through the DMOS of the BTS5200-4EKA, which can be recognized at the current sense signal. The open load at OFF detection circuitry can also be used to distinguish a short circuit to V_S . In that case, an external resistor to ground R_{SC_VS} is required. **Figure 26** gives a sketch of the situation.

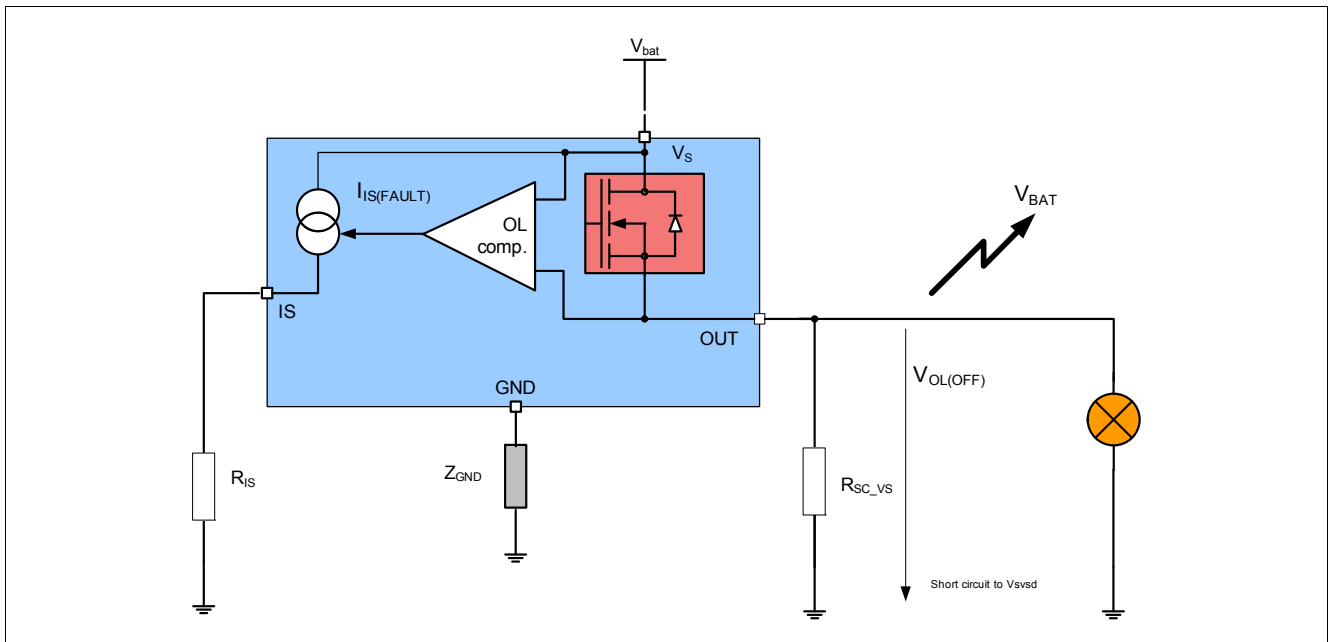

Figure 26 Short Circuit to Battery Detection in OFF Electrical Equivalent Circuit

7.3.5 SENSE Signal in Case of Overload

An overload condition is defined by a current flowing out of the DMOS reaching the current limitation and / or the absolute dynamic temperature swing $T_{J(SW)}$ is reached, and / or the junction temperature reaches the thermal shutdown temperature $T_{J(SC)}$. Please refer to **Chapter 6.5** for details.

In that case, the SENSE signal given is by $I_{IS(FAULT)}$ when the diagnostic is selected.

The device has an thermal restart behavior, such that when the overtemperature or the exceed dynamic temperature condition has disappeared, the DMOS is reactivated if the IN is still at logical level one. If the DEN pin is activated, and DSEL pin is selected to the correct channel, the IS pin is not toggling with the restart mechanism and remains to $I_{IS(FAULT)}$.

7.3.6 SENSE Signal in Case of Inverse Current

In the case of inverse current, the sense signal of the affected channel will indicate open load in OFF state and indicate open load in ON state. The unaffected channels indicate normal behavior as long as the I_{INV} current is not exceeding the maximum value specified in **Chapter 5.4**.

7.4 Electrical Characteristics Diagnostic Function

Measurement setup used for k_{ILIS} (unless otherwise specified):

All channels are ON at the same time with equal I_L .

Table 9 Electrical Characteristics: Diagnostics

$V_S = 8\text{ V to }18\text{ V}$, $T_J = -40^\circ\text{C to }150^\circ\text{C}$ (unless otherwise specified).

Typical values are given at $V_S = 13.5\text{ V}$, $T_J = 25^\circ\text{C}$

Parameter	Symbol	Values			Unit	Note / Test Condition	Number
		Min.	Typ.	Max.			
Load Condition Threshold for Diagnostic							
Open load detection threshold in OFF state	$V_S - V_{OL(OFF)}$	4	–	6	V	¹⁾ $V_{IN} = 0\text{ V}$ $V_{DEN} = 4.5\text{ V}$ See Figure 25	P_7.5.1
Open load detection threshold in ON state	$I_{L(OL)}$	2	–	9	mA	$V_{IN} = V_{DEN} = 4.5\text{ V}$ $I_{IS(OL)} = 15\text{ }\mu\text{A}$ See Figure 23 See Chapter 9.4	P_7.5.2
Sense Pin							
IS pin leakage current when sense is disabled	$I_{IS(DIS)}$	–	–	1	μA	¹⁾ $V_{IN} = 4.5\text{ V}$ $V_{DEN} = 0\text{ V}$ $I_L = I_{L4} = 0.5\text{ A}$	P_7.5.4
Sense signal saturation voltage	$V_S - V_{IS(RANGE)}$	1	–	3	V	³⁾ $V_{IN} = 0\text{ V}$ $V_{OUT} = V_S > 10\text{ V}$ $V_{DEN} = 4.5\text{ V}$ $I_{IS} = 6\text{ mA}$ See Chapter 9.4	P_7.5.6
Sense signal maximum current in fault condition	$I_{IS(FAULT)}$	6	15	30	mA	$V_{IS} = V_{IN} = V_{DSEL} = 0\text{ V}$ $V_{OUT} = V_S > 10\text{ V}$ $V_{DEN} = 4.5\text{ V}$ See Figure 19 See Chapter 9.4	P_7.5.7
Sense pin maximum voltage	$V_{IS(AZ)}$	41	47	53	V	$I_{IS} = 5\text{ mA}$ See Figure 19	P_7.5.3
Current Sense Ratio Signal in the Nominal Area, Stable Load Current Condition							
Current sense ratio $I_{L0} = 10\text{ mA}$	k_{ILIS0}	-50%	360	+50%		$V_{IN} = 4.5\text{ V}$ $V_{DEN} = 4.5\text{ V}$ See Figure 20 $T_J = -40^\circ\text{C}; 150^\circ\text{C}$	P_7.5.8
Current sense ratio $I_{L1} = 0.025\text{ A}$	k_{ILIS1}	-35%	350	+35%			P_7.5.9
Current sense ratio $I_{L2} = 0.05\text{ A}$	k_{ILIS2}	-22%	340	+22%			P_7.5.10
Current sense ratio $I_{L3} = 0.1\text{ A}$	k_{ILIS3}	-18%	330	+18%			P_7.5.11
Current sense ratio $I_{L4} = 0.5\text{ A}$	k_{ILIS4}	-10%	320	+10%			P_7.5.12
k_{ILIS} derating with current and temperature	Δk_{ILIS}	-8	0	+8	%	³⁾ k_{ILIS4} versus k_{ILIS3} See Figure 21	P_7.5.17
Diagnostic Timing in Normal Condition							

Table 9 Electrical Characteristics: Diagnostics (cont'd)

$V_S = 8\text{ V to }18\text{ V}$, $T_J = -40^\circ\text{C to }150^\circ\text{C}$ (unless otherwise specified).
 Typical values are given at $V_S = 13.5\text{ V}$, $T_J = 25^\circ\text{C}$

Parameter	Symbol	Values			Unit	Note / Test Condition	Number
		Min.	Typ.	Max.			
Current sense settling time to k_{ILIS} function stable after positive input slope on both INput and DEN	$t_{sIS(ON)}$	0	–	250	μs	³⁾ $V_{DEN} = V_{IN} = 0$ to 4.5 V $V_S = 13.5\text{ V}$ $R_{IS} = 1.2\text{ k}\Omega$ $C_{SENSE} < 100\text{ pF}$ $I_L = I_{L4} = 0.5\text{ A}$	P_7.5.18
Current sense settling time with load current stable and transition of the DEN	$t_{sIS(ON_DEN)}$	0	–	20	μs	¹⁾ $V_{IN} = 4.5\text{ V}$ $V_{DEN} = 0$ to 4.5 V $R_{IS} = 1.2\text{ k}\Omega$ $C_{SENSE} < 100\text{ pF}$ $I_L = I_{L4} = 0.5\text{ A}$ See Figure 22	P_7.5.19
Current sense settling time to I_{IS} stable after positive input slope on current load	$t_{sIS(LC)}$	0	–	20	μs	¹⁾ $V_{IN} = 4.5\text{ V}$ $V_{DEN} = 4.5\text{ V}$ $R_{IS} = 1.2\text{ k}\Omega$ $C_{SENSE} < 100\text{ pF}$ $I_L = I_{L3} = 0.1\text{ A}$ to $I_L = I_{L4} = 0.5\text{ A}$ See Figure 22	P_7.5.20
Diagnostic Timing in Open Load Condition							
Current sense settling time to I_{IS} stable for open load detection in OFF state	$t_{sIS(FAULT_OL_OFF)}$	0	–	100	μs	¹⁾ $V_{IN} = 0\text{ V}$ $V_{DEN} = 0$ to 4.5 V $R_{IS} = 1.2\text{ k}\Omega$ $C_{SENSE} < 100\text{ pF}$ $V_{OUT} = V_S = 13.5\text{ V}$ See Figure 25	P_7.5.22
Current sense settling time to I_{IS} stable for open load detection in ON-OFF transition	$t_{sIS(FAULT_OL_ON_OFF)}$	0	200	450	μs	¹⁾ $V_{IN} = 4.5\text{ V to }0$ $V_{DEN} = 4.5\text{ V}$ $R_{IS} = 1.2\text{ k}\Omega$ $C_{SENSE} < 100\text{ pF}$ $V_{OUT} = V_S = 13.5\text{ V}$	P_7.5.23
Diagnostic Timing in Overload Condition							
Current sense settling time to I_{IS} stable for overload detection	$t_{sIS(FAULT)}$	0	–	250	μs	¹⁾²⁾ $V_{IN} = V_{DEN} = 0$ to 4.5 V $R_{IS} = 1.2\text{ k}\Omega$ $C_{SENSE} < 100\text{ pF}$ $V_{DS} = 5\text{ V}$ See Figure 18	P_7.5.24
Current sense over temperature blanking time	$t_{sIS(OT_blank)}$	–	350	–	μs	³⁾ $V_{IN} = V_{DEN} = 4.5\text{ V}$ $R_{IS} = 1.2\text{ k}\Omega$ $C_{SENSE} < 100\text{ pF}$ $V_{DS} = 5\text{ V to }0\text{ V}$ See Figure 18	P_7.5.32

Table 9 Electrical Characteristics: Diagnostics (cont'd)

$V_S = 8\text{ V to }18\text{ V}$, $T_J = -40^\circ\text{C to }150^\circ\text{C}$ (unless otherwise specified).
 Typical values are given at $V_S = 13.5\text{ V}$, $T_J = 25^\circ\text{C}$

Parameter	Symbol	Values			Unit	Note / Test Condition	Number
		Min.	Typ.	Max.			
Diagnostic disable time DEN transition to $I_{IS} < 50\% I_L / k_{ILIS}$	$t_{sIS(OFF)}$	0	–	30	μs	1) $V_{IN} = 4.5\text{ V}$ $V_{DEN} = 4.5\text{ V to }0\text{ V}$ $R_{IS} = 1.2\text{ k}\Omega$ $C_{SENSE} < 100\text{ pF}$ $I_L = I_{L4} = 0.5\text{ A}$ See Figure 22	P_7.5.25
Current sense settling time from one channel to another	$t_{sIS(ChC)}$	0	–	20	μs	$V_{IN0} = V_{IN1} = 4.5\text{ V}$ $V_{DEN} = 4.5\text{ V}$ $V_{DSEL} = 0\text{ to }4.5\text{ V}$ $R_{IS} = 1.2\text{ k}\Omega$ $C_{SENSE} < 100\text{ pF}$ $I_{L(OUT0)} = I_{L4} = 0.5\text{ A}$ $I_{L(OUT1)} = I_{L3} = 0.1\text{ A}$ See Figure 22	P_7.5.26

- 1) DSEL pin select channel 0 only.
- 2) Test at $T_J = -40^\circ\text{C}$ only
- 3) Not subject to production test, specified by design

8 Input Pins

8.1 Input Circuitry

The input circuitry is compatible with 3.3 and 5 V microcontrollers. The concept of the input pin is to react to voltage thresholds. An implemented Schmitt trigger avoids any undefined state if the voltage on the input pin is slowly increasing or decreasing. The output is either OFF or ON but cannot be in a linear or undefined state. The input circuitry is compatible with PWM applications. [Figure 27](#) shows the electrical equivalent input circuitry. In case the pin is not needed, it must be left opened, or must be connected to device ground (and not module ground) via an input resistor.

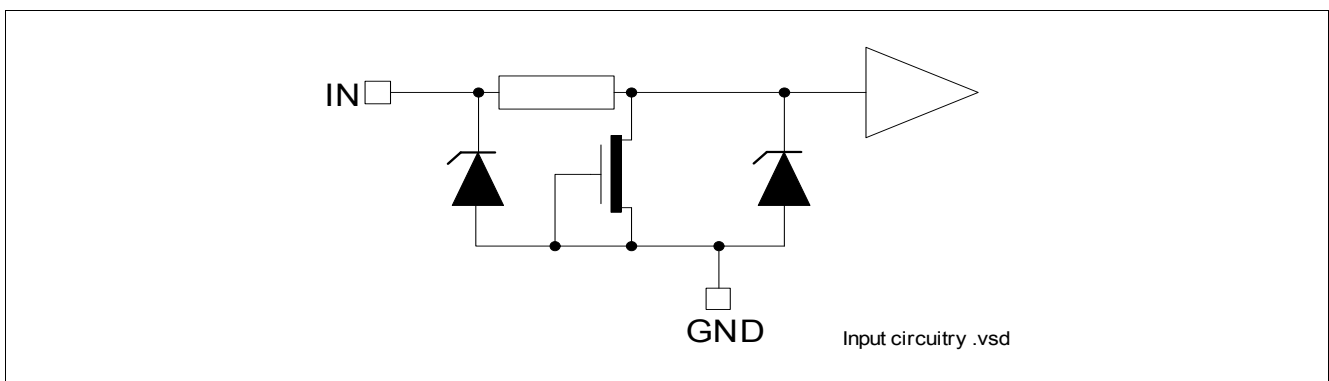

Figure 27 Input Pin Circuitry

8.2 DEN / DSEL0,1 Pin

The DEN / DSEL0,1 pins enable and disable the diagnostic functionality of the device. The pins have the same structure as the INput pins, please refer to [Figure 27](#).

8.3 Input Pin Voltage

The IN, DSEL and DEN use a comparator with hysteresis. The switching ON / OFF takes place in a defined region, set by the thresholds $V_{IN(L)}$ Max. and $V_{IN(H)}$ Min. The exact value where the ON and OFF take place are unknown and depends on the process, as well as the temperature. To avoid cross talk and parasitic turn ON and OFF, a hysteresis is implemented. This ensures a certain immunity to noise.

8.4 Electrical Characteristics

Table 10 Electrical Characteristics: Input Pins
 $V_S = 8\text{ V to }18\text{ V}$, $T_J = -40^\circ\text{C to }150^\circ\text{C}$ (unless otherwise specified).

 Typical values are given at $V_S = 13.5\text{ V}$, $T_J = 25^\circ\text{C}$

Parameter	Symbol	Values			Unit	Note / Test Condition	Number
		Min.	Typ.	Max.			
Input Pins Characteristics							
Low level input voltage range	$V_{IN(L)}$	-0.3	–	0.8	V	See Chapter 9.5	P_8.4.1
High level input voltage range	$V_{IN(H)}$	2	–	6	V	See Chapter 9.5	P_8.4.2
Input voltage hysteresis	$V_{IN(HYS)}$	–	250	–	mV	¹⁾ See Chapter 9.5	P_8.4.3
Low level input current	$I_{IN(L)}$	1	10	20	μA	$V_{IN} = 0.8\text{ V}$	P_8.4.4
High level input current	$I_{IN(H)}$	2	10	25	μA	$V_{IN} = 5.5\text{ V}$ See Chapter 9.5	P_8.4.5
DEN Pin							
Low level input voltage range	$V_{DEN(L)}$	-0.3	–	0.8	V	–	P_8.4.6
High level input voltage range	$V_{DEN(H)}$	2	–	6	V	–	P_8.4.7
Input voltage hysteresis	$V_{DEN(HYS)}$	–	250	–	mV	¹⁾	P_8.4.8
Low level input current	$I_{DEN(L)}$	1	10	20	μA	$V_{DEN} = 0.8\text{ V}$	P_8.4.9
High level input current	$I_{DEN(H)}$	2	10	25	μA	$V_{DEN} = 5.5\text{ V}$	P_8.4.10
DSEL Pins							
Low level input voltage range	$V_{DSEL(L)}$	-0.3	–	0.8	V	–	P_8.4.11
High level input voltage range	$V_{DSEL(H)}$	2	–	6	V	–	P_8.4.12
Input voltage hysteresis	$V_{DSEL(HYS)}$	–	250	–	mV	¹⁾	P_8.4.13
Low level input current	$I_{DSEL(L)}$	1	10	20	μA	$V_{DSEL} = 0.8\text{ V}$	P_8.4.14
High level input current	$I_{DSEL(H)}$	2	10	25	μA	$V_{DSEL} = 5.5\text{ V}$	P_8.4.15

¹⁾ Not subject to production test, specified by design

9 Characterization Results

The characterization have been performed on 3 lots, with 3 devices each. Characterization have been performed at 8 V, 13.5 V and 18 V over temperature range. When there is no voltage dependency seen, only a single curve is sketched.

9.1 General Product Characteristics

P_4.2.3

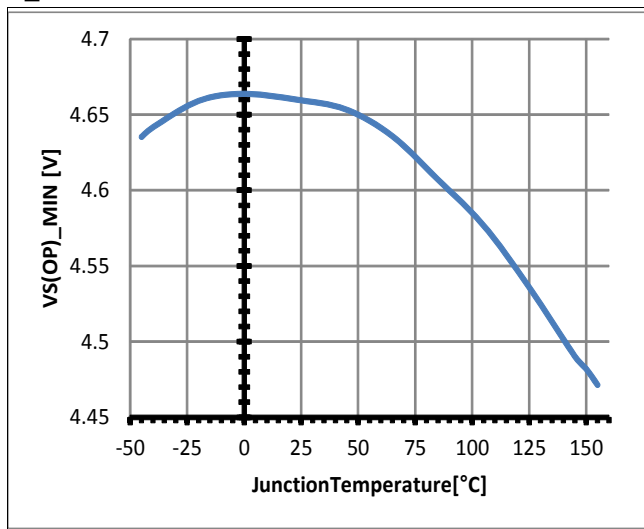

Minimum Functional Supply Voltage

$$V_{S(OP)_{MIN}} = f(T_J)$$

P_4.2.4

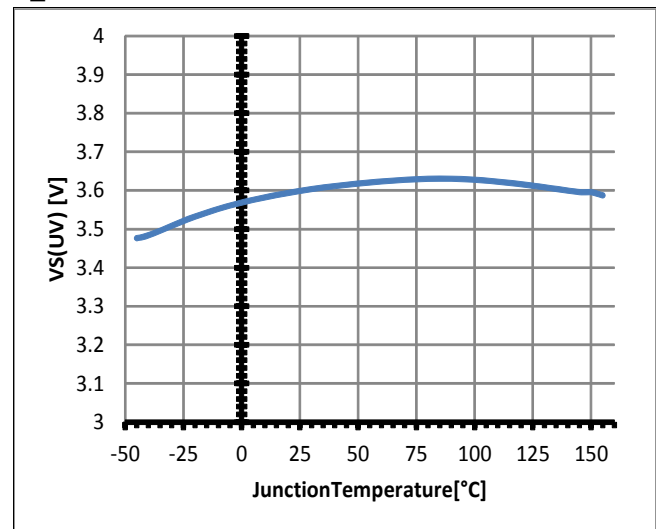

Undervoltage Threshold $V_{S(UV)} = f(T_J)$

P_4.2.6

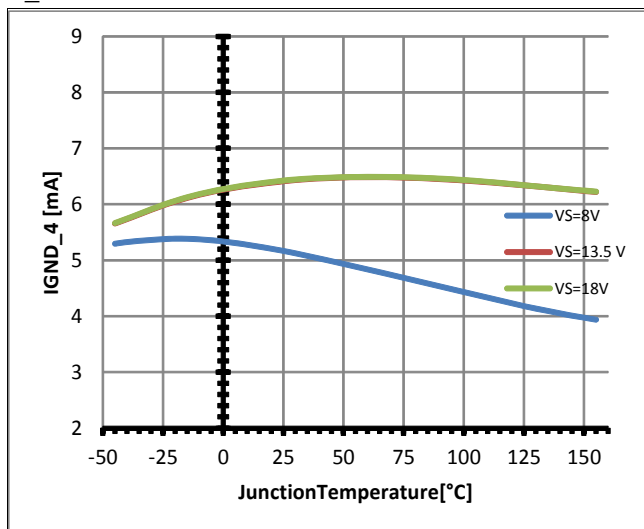

Current Consumption for Whole Device with Load. All Channels Active $I_{GND_4} = f(T_J; V_S)$

P_4.2.7, P_4.2.10

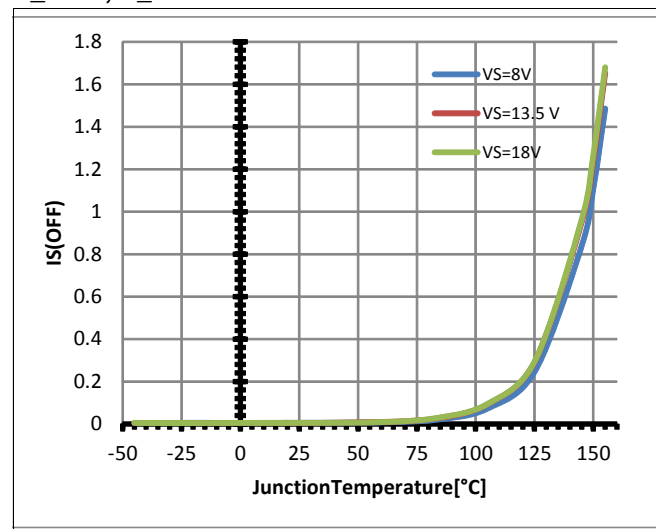

Standby Current for Whole Device with Load. $I_{S(OFF)} = f(T_J; V_S)$

9.2 Power Stage

P_5.5.4

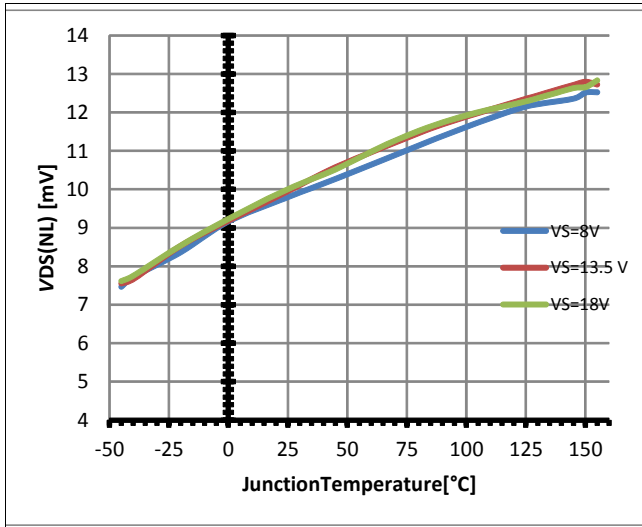

Output Voltage Drop Limitation at Low Load Current
 $V_{DS(NL)} = f(T_J; V_S)$

P_5.5.5

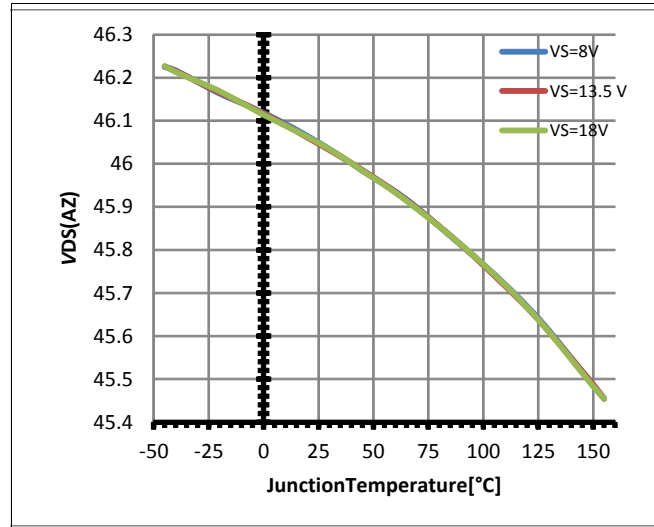

Drain to Source Clamp Voltage $V_{DS(AZ)} = f(T_J)$

P_5.5.11

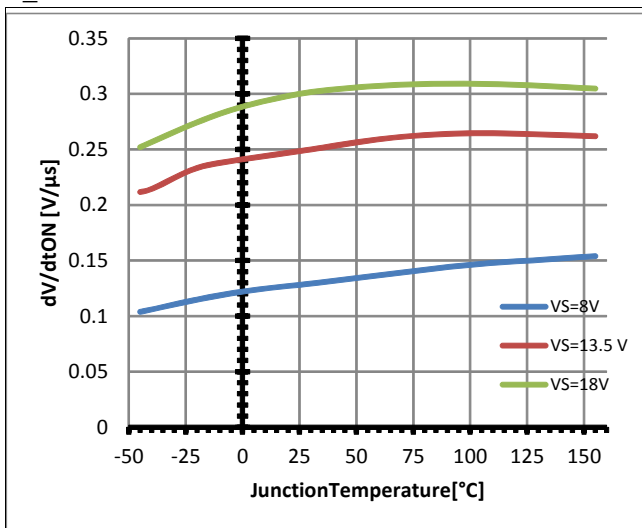

Slew Rate at Turn ON
 $dV/dt_{ON} = f(T_J; V_S), R_L = 25 \Omega$

P_5.5.12

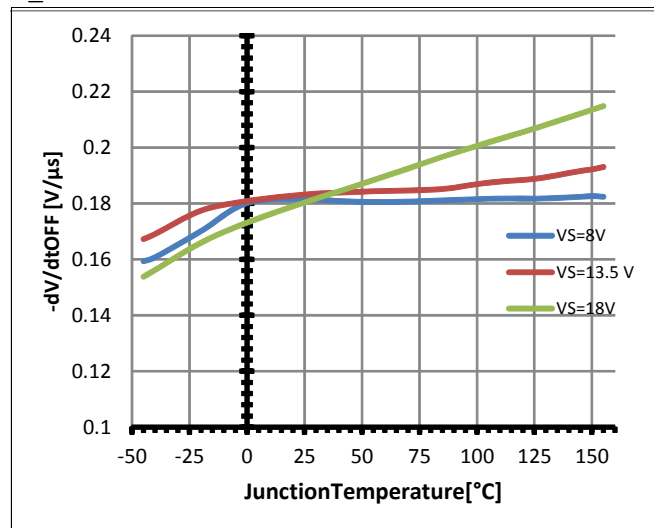

Slew Rate at Turn OFF
 $-dV/dt_{OFF} = f(T_J; V_S), R_L = 25 \Omega$

P_5.5.14

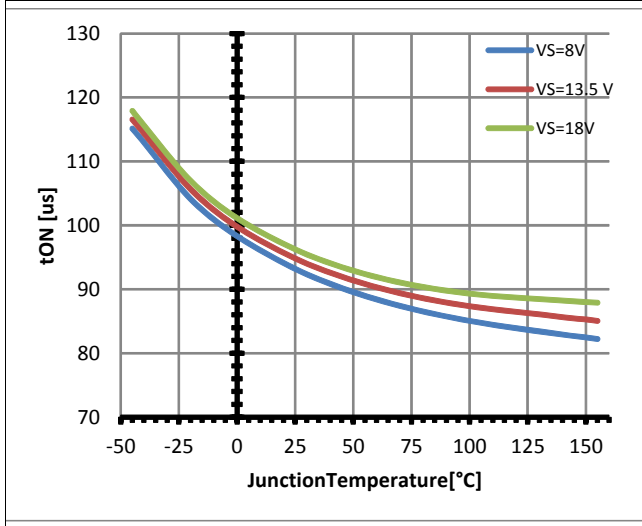

Turn ON $T_{ON} = f(T_J; V_S), R_L = 25 \Omega$

P_5.5.15

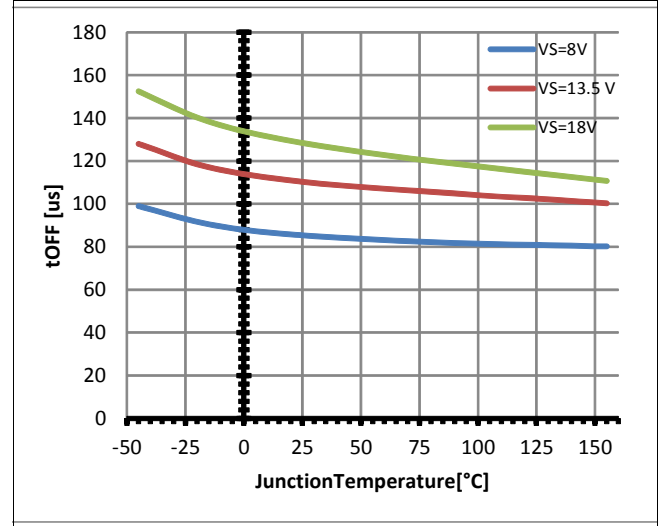

Turn OFF $T_{OFF} = f(T_J; V_S), R_L = 25 \Omega$

P_5.5.19

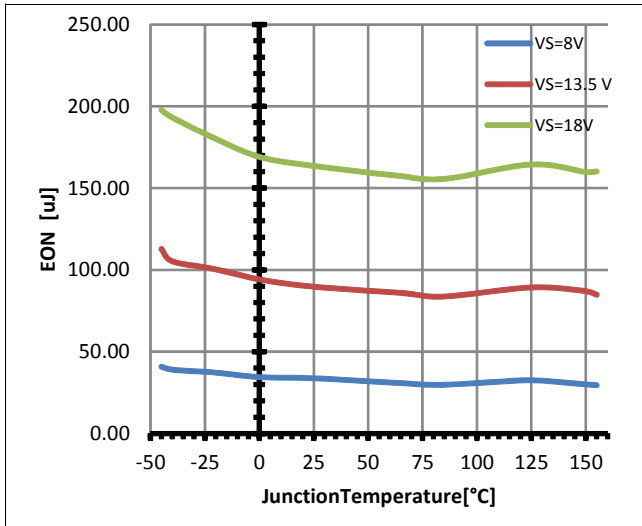

Switch ON Energy $E_{ON} = f(T_J; V_S), R_L = 25 \Omega$

P_5.5.20

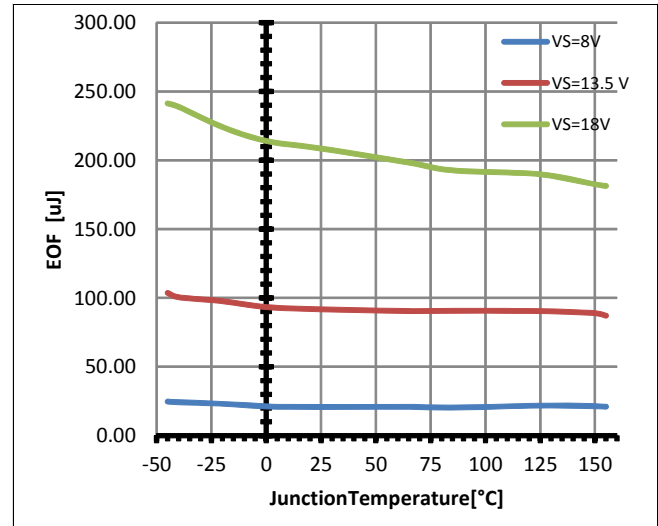

Switch OFF Energy $E_{OFF} = f(T_J; V_S), R_L = 25 \Omega$

9.3 Protection Functions

P_6.6.4

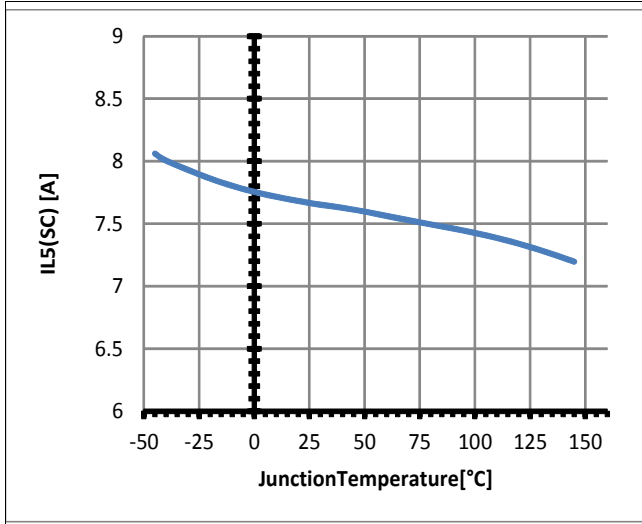

Overload Condition in the Low Voltage Area

$$I_{L5(SC)} = f(T_J);$$

P_6.6.7

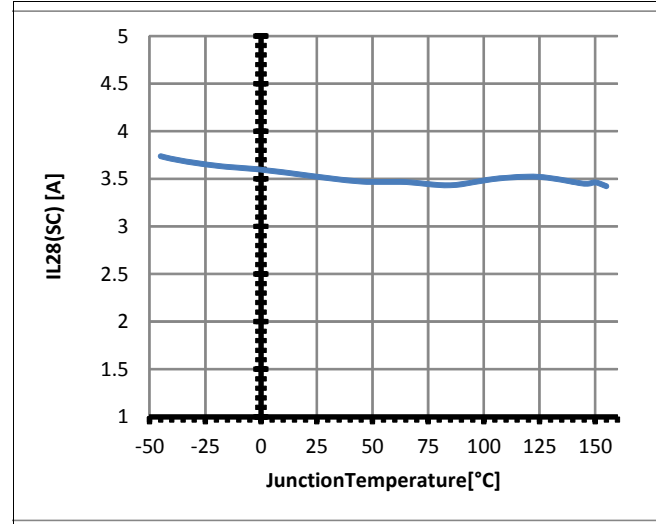

Overload Condition in the High Voltage Area

$$I_{L28(SC)} = f(T_J);$$

9.4 Diagnostic Mechanism

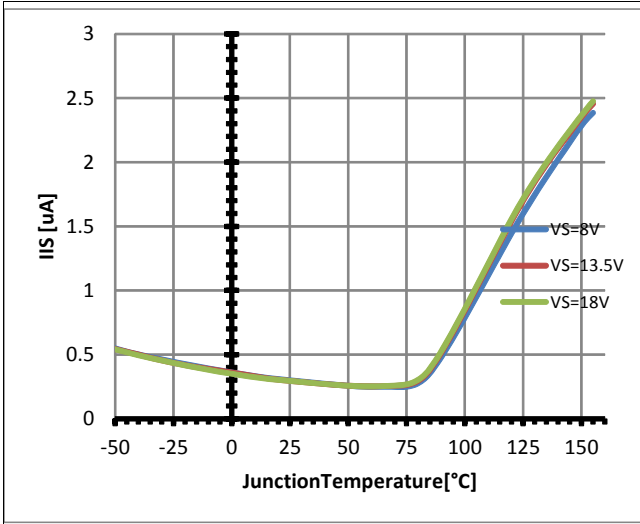

Current Sense at no Load I_{IS}
 $= f(T_J), I_L = 0$

P_7.5.2

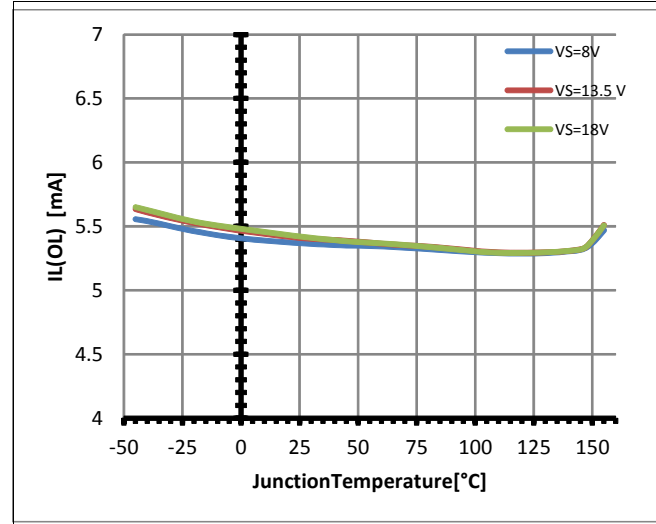

Open Load Detection ON State Threshold $I_{IL(OL)}$
 $= f(T_J; V_S)$

P_7.5.3

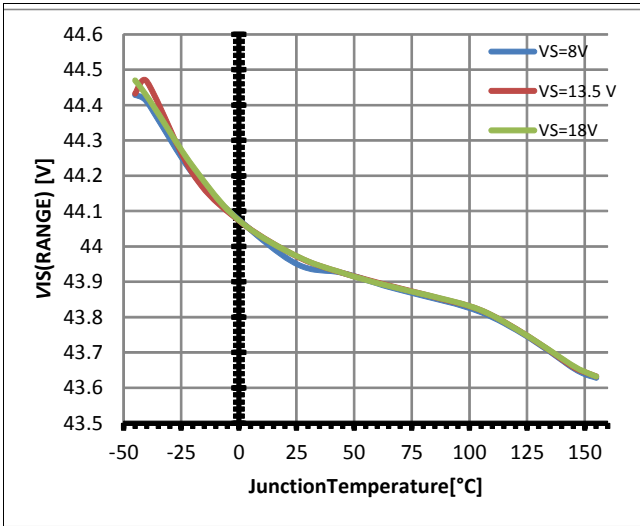

Sense Signal Maximum Voltage (Clamping Voltage)
 $V_{IS(AZ)} = f(T_J)$

P_7.5.7

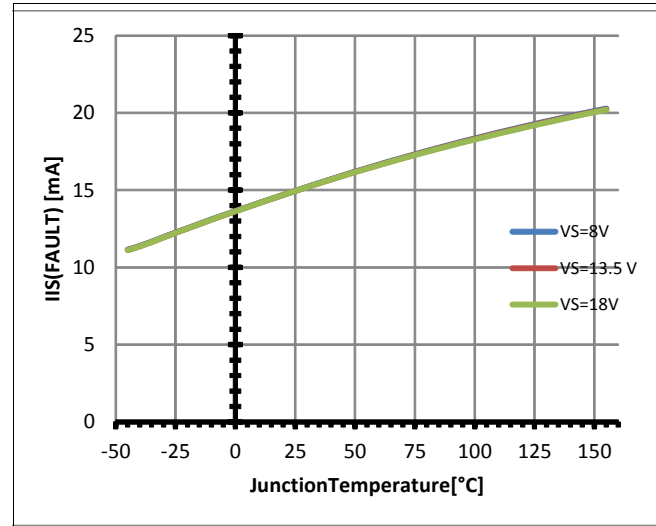

Sense Signal Maximum Current in Fault Condition
 $I_{S(FAULT)} = f(T_J)$

9.5 Input Pins

P_8.4.1

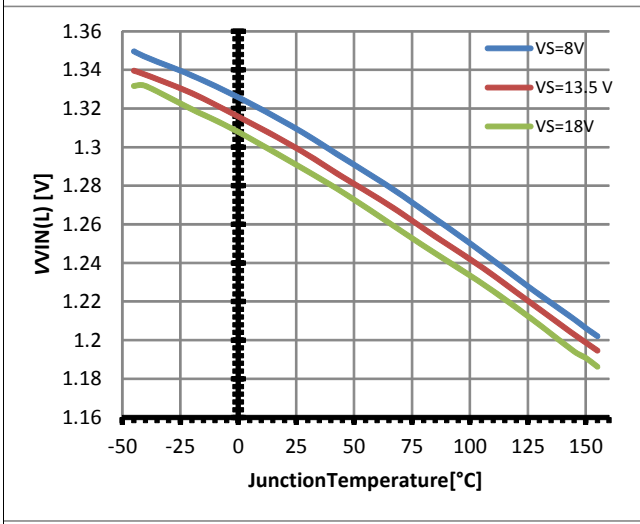

Input Voltage Threshold

$$V_{VIN(L)} = f(T_J; V_S)$$

P_8.4.2

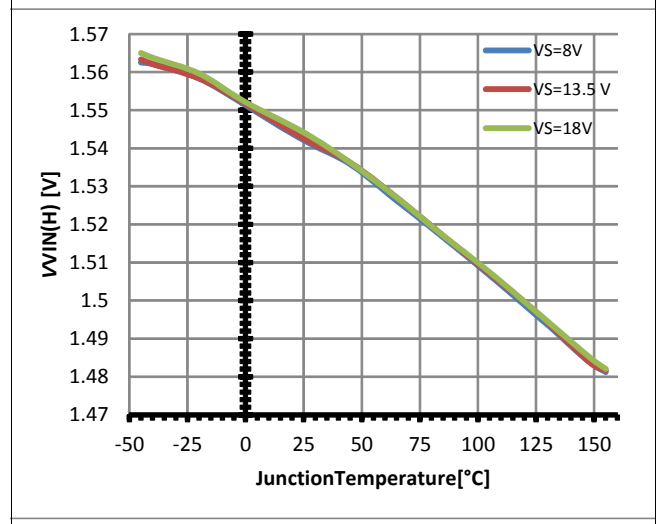

Input Voltage Threshold

$$V_{VIN(H)} = f(T_J; V_S)$$

P_8.4.3

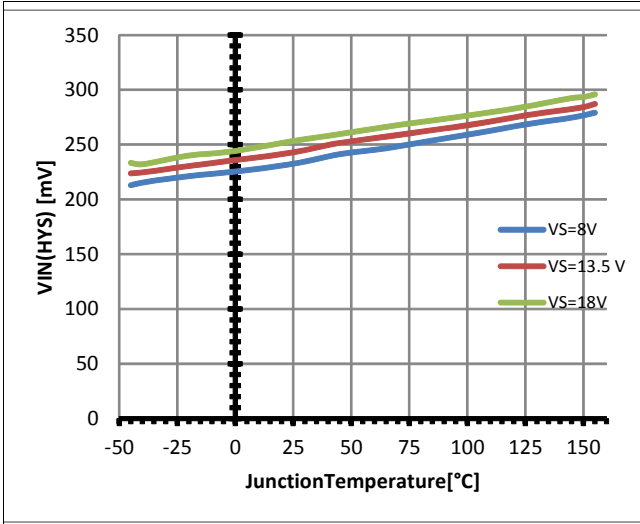

Input Voltage Hysteresis

$$V_{IN(HYS)} = f(T_J; V_S)$$

P_8.4.5

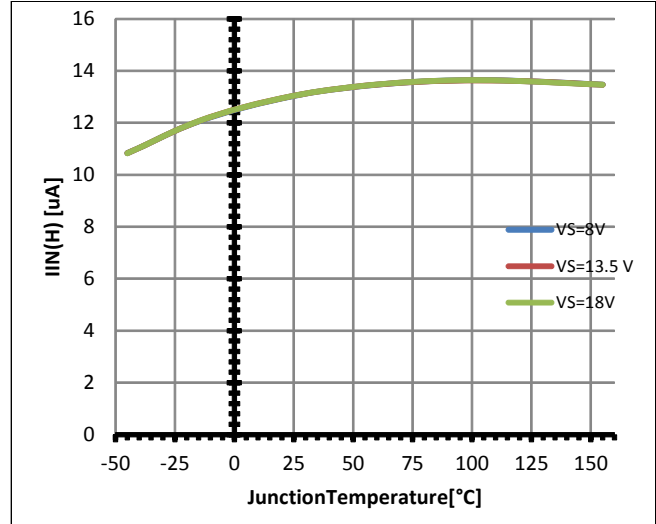

Input Current High Level

$$I_{IN(H)} = f(T_J)$$

10 Application Information

Note: The following information is given as a hint for the implementation of the device only and shall not be regarded as a description or warranty of a certain functionality, condition or quality of the device.

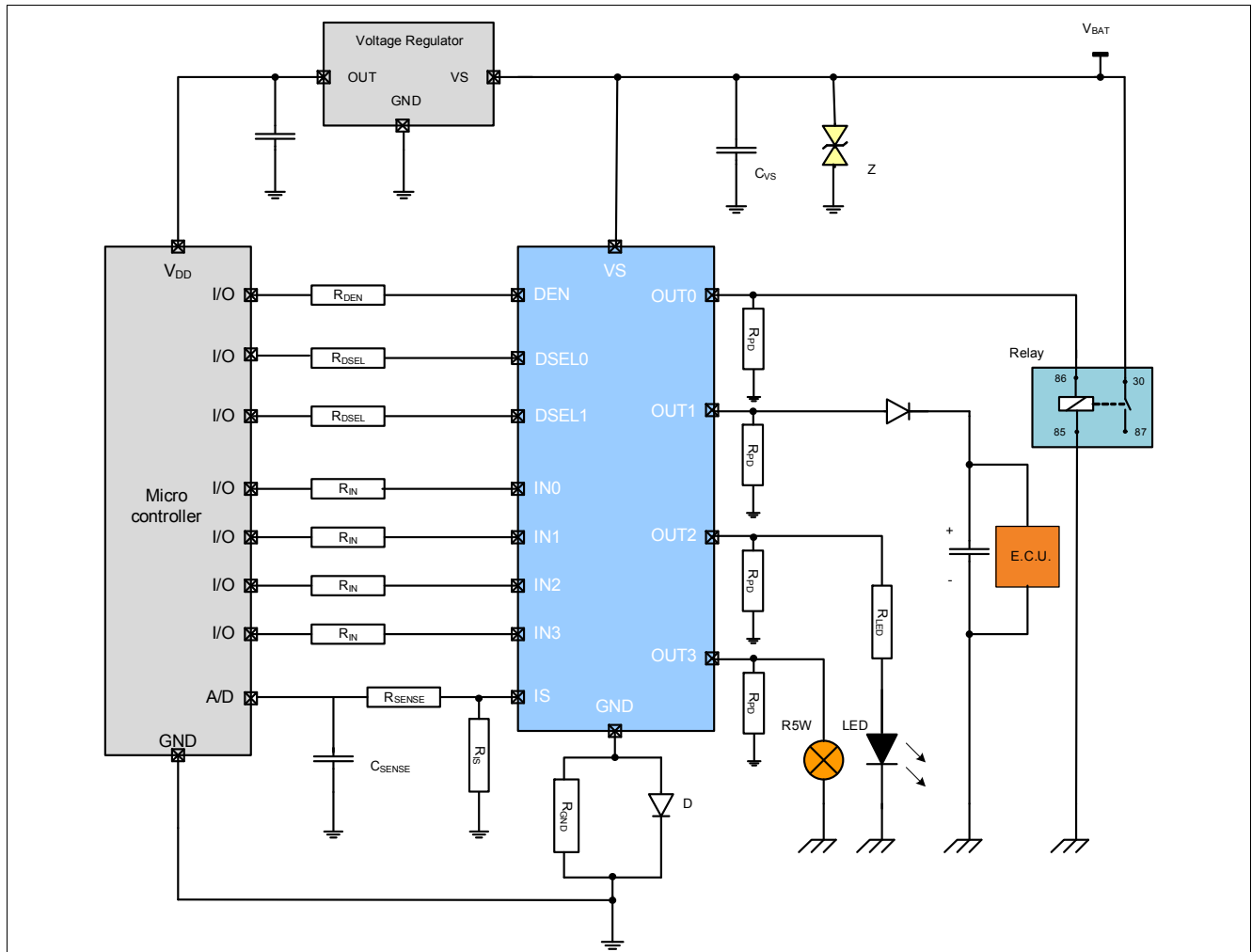

Figure 28 Application Diagram with BTS5200-4EKA

Note: This is a very simplified example of an application circuit. The function must be verified in the real application.

Table 11 Bill of Material

Reference	Value	Purpose
R_{IN}	10 k Ω	Protection of the microcontroller during overvoltage, reverse polarity Guarantee BTS5200-4EKA channels OFF during loss of ground
R_{DSEL}	10 k Ω	Protection of the microcontroller during overvoltage, reverse polarity
R_{DEN}	10 k Ω	Protection of the microcontroller during overvoltage, reverse polarity
R_{PD}	47 k Ω	Polarization of the output for short circuit to VS detection Improve BTS5200-4EKA immunity to electromagnetic noise
R_{IS}	1.2 k Ω	Sense resistor
R_{SENSE}	4.7 k Ω	Overvoltage, reverse polarity, loss of ground. Value to be tuned with micro controller specification.

Table 11 Bill of Material (cont'd)

Reference	Value	Purpose
C_{SENSE}	100 pF	Sense signal filtering.
R_{LED}	680 Ω	Overvoltage protection of the LED. Value to be tuned with LED specification.
R_{GND}	1 k Ω	Protection of the BTS5200-4EKA during loss of inductive load
D	BAS21	Protection of the BTS5200-4EKA during reverse polarity
Z	36 V Zener diode	Protection of the device during overvoltage
C_{VS}	100 nF	Filtering of voltage spikes at the battery line

10.1 Further Application Information

Please contact us to get

- Existing App. Notes
- For further information you may visit <http://www.infineon.com/profet>

11 Package Outlines

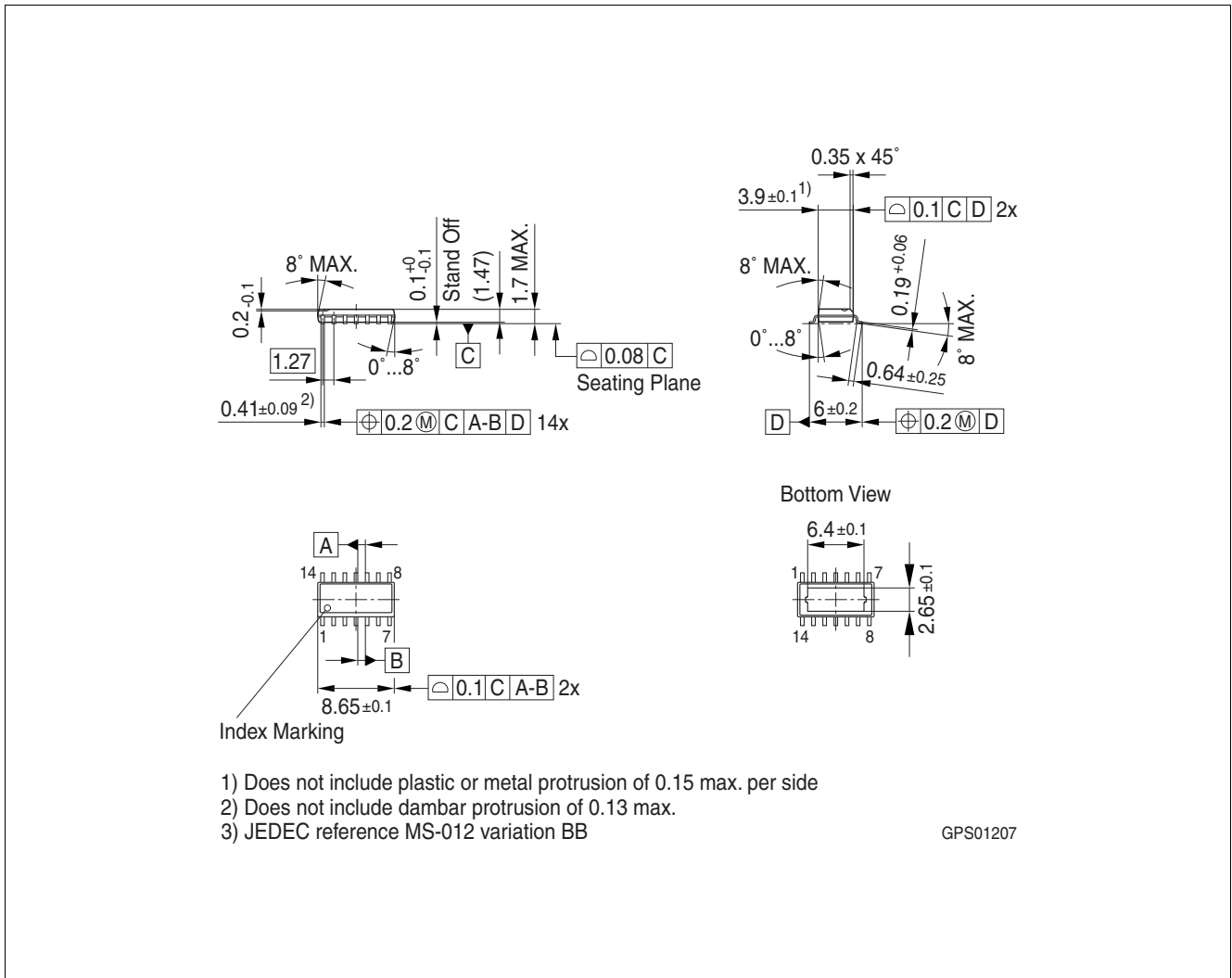

Figure 29 PG-DSO-14-48-EP (Plastic Dual Small Outline Package) (RoHS-Compliant)

Green Product (RoHS compliant)

To meet the world-wide customer requirements for environmentally friendly products and to be compliant with government regulations the device is available as a green product. Green products are RoHS-Compliant (i.e Pb-free finish on leads and suitable for Pb-free soldering according to IPC/JEDEC J-STD-020).

12 Revision History

Revision	Date	Changes
1.0	2014-02-06	Creation of the document

Edition 2014-02-06

**Published by
Infineon Technologies AG
81726 Munich, Germany**

**© 2014 Infineon Technologies AG
All Rights Reserved.**

Legal Disclaimer

The information given in this document shall in no event be regarded as a guarantee of conditions or characteristics. With respect to any examples or hints given herein, any typical values stated herein and/or any information regarding the application of the device, Infineon Technologies hereby disclaims any and all warranties and liabilities of any kind, including without limitation, warranties of non-infringement of intellectual property rights of any third party.

Legal Disclaimer for short-circuit capability

Infineon disclaims any warranties and liabilities, whether expressed nor implied, for any short-circuit failures below the threshold limit.

Information

For further information on technology, delivery terms and conditions and prices, please contact the nearest Infineon Technologies Office (www.infineon.com).

Warnings

Due to technical requirements, components may contain dangerous substances. For information on the types in question, please contact the nearest Infineon Technologies Office.

Infineon Technologies components may be used in life-support devices or systems only with the express written approval of Infineon Technologies, if a failure of such components can reasonably be expected to cause the failure of that life-support device or system or to affect the safety or effectiveness of that device or system. Life support devices or systems are intended to be implanted in the human body or to support and/or maintain and sustain and/or protect human life. If they fail, it is reasonable to assume that the health of the user or other persons may be endangered.