

# BTS6110-1SJA

Smart High-Side Power Switch

## Data Sheet

Rev. 1.1, 2014-11-24

## Table of Contents

<b>1</b>	<b>Overview</b> .....	<b>3</b>
<b>2</b>	<b>Block Diagram</b> .....	<b>4</b>
<b>3</b>	<b>Application Information</b> .....	<b>4</b>
<b>4</b>	<b>Pin Configuration</b> .....	<b>5</b>
4.1	Pin Assignment .....	5
4.2	Pin Definitions and Functions .....	5
4.3	Voltage and Current Definition .....	5
<b>5</b>	<b>General Product Characteristics</b> .....	<b>6</b>
5.1	Absolute Maximum Ratings .....	6
5.2	Functional Range .....	7
5.3	Thermal Resistance .....	7
5.3.1	PCB set up .....	7
5.3.2	Thermal Resistance .....	8
<b>6</b>	<b>Power Stage</b> .....	<b>9</b>
6.1	Output ON-state Resistance .....	9
6.2	Turn ON/OFF Characteristics with Resistive Load .....	9
6.3	Frequency Generator .....	10
6.4	Timing Output .....	10
6.5	Output Polarization .....	11
6.6	CAP Pin .....	13
<b>7</b>	<b>Protection Functions</b> .....	<b>14</b>
7.1	Overvoltage Protection .....	14
7.2	Reverse Polarity Protection .....	14
7.3	Overload Protection .....	15
7.3.1	Current Limitation .....	15
7.3.2	Temperature Limitation in the Power DMOS .....	15
<b>8</b>	<b>Diagnostic Functions</b> .....	<b>16</b>
8.1	Load Current Measurement .....	16
8.2	Under load Current .....	17
<b>9</b>	<b>Electrical Characteristics</b> .....	<b>18</b>
9.1	Electrical Characteristics Power Stage .....	18
9.2	Electrical Characteristics CAP pin .....	19
9.3	Electrical Characteristics for the Protection Functions .....	20
9.4	Electrical Characteristics Diagnostic Function .....	21
<b>10</b>	<b>Package Outlines</b> .....	<b>22</b>
<b>11</b>	<b>Revision History</b> .....	<b>23</b>



# 1 Overview

## Application

- Side Indicator 2 x R10W + 1 x R2W

## Basic Features

- One channel device
- Very small external reservoir capacitor of 10  $\mu$ F
- Electrostatic discharge protection (ESD)
- Optimized electromagnetic compatibility
- Green product (RoHS compliant)
- AEC qualified

## Protection Functions

- Overtemperature protection with limited restart
- Overvoltage protection without external component

## Diagnostic Functions

- Auto-failure detection of a failed main lamp (N-1 diagnosis), signaled by frequency doubling

## Description

The BTS6110-1SJA is a single 80 m $\Omega$  channel Smart High-Side Power Switch, embedded in a PG-DSO-8-49 package, providing protective functions and diagnosis. It is designed to drive lamps 2 x R10W + 1 x R2W to realize the side indicators function for motorcycle.



Package	Marking
PG-DSO-8-49	6110-SJA

**Table 1 Product Summary**

Parameter	Symbol	Value
Operating voltage range	$V_{S(OP)}$	9 V ... 16 V
Load dump voltage	$V_{S(LD)}$	65 V
Maximum ON state resistance at $T_J = 150\text{ }^\circ\text{C}$	$R_{DS(ON)}$	200 m $\Omega$
Flasher Frequency ; normal operation	$f_4$	85 $\pm$ 15 cycles / minute <sup>1)</sup>
Flasher Frequency; loss of a main lamp / typical value	$f_2$	$f_4 * 2.24$
Minimum current limitation	$I_{L(SC)}$	20 A

1) With external capacitor CEXT = 10 $\mu$ F

## 2 Block Diagram

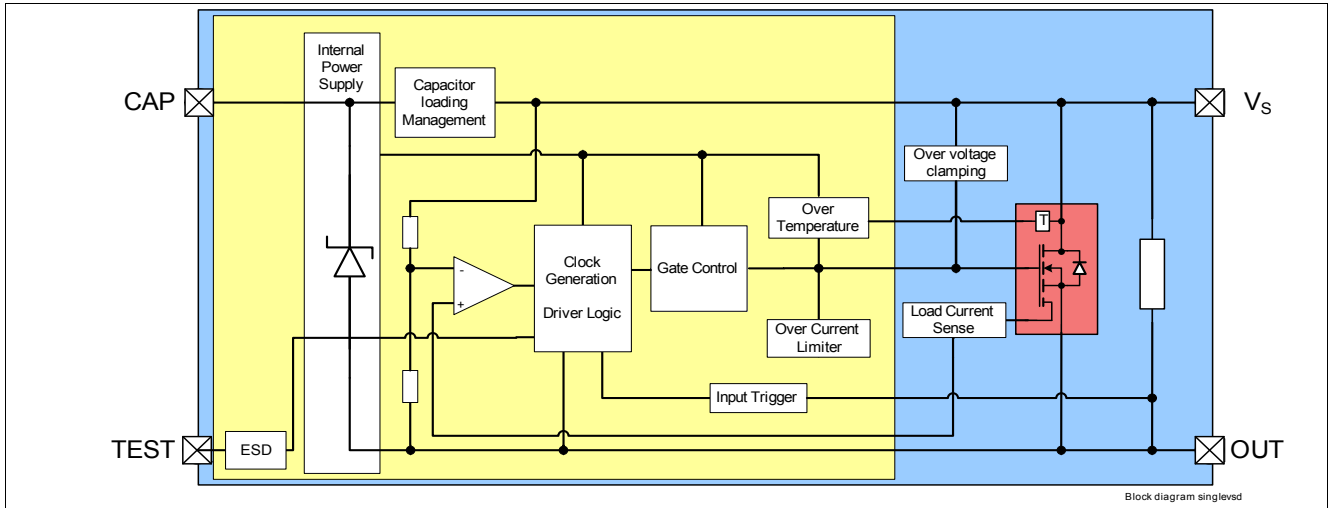

Figure 1 BTS6110-1SJA Block Diagram

## 3 Application Information

Note: The following information is given as a hint for the implementation of the device only and shall not be regarded as a description or warranty of a certain functionality, condition or quality of the device.

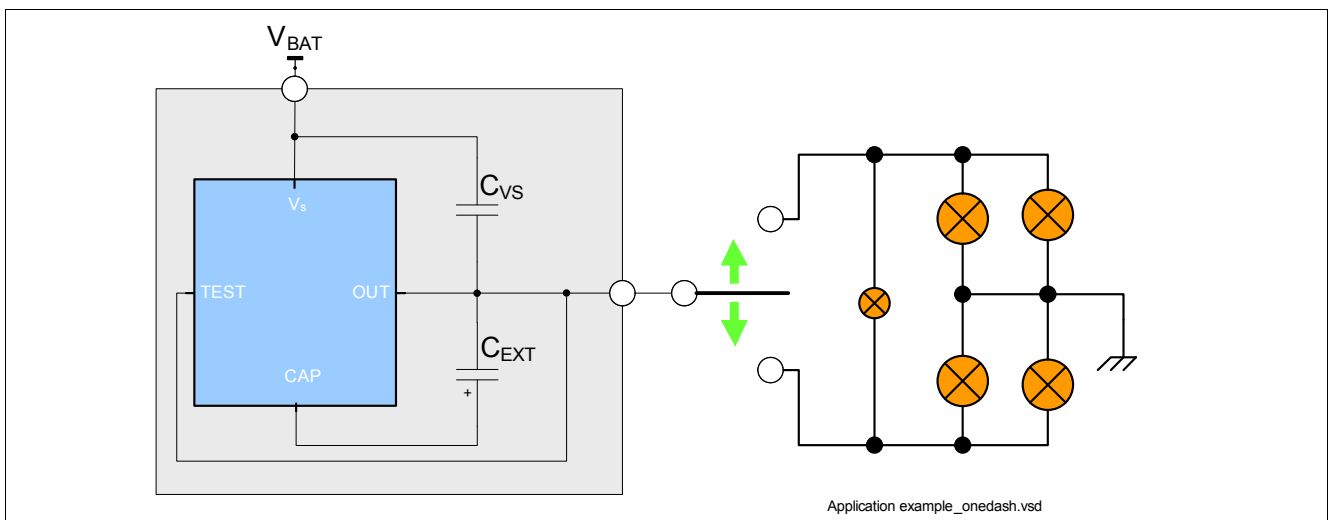

Figure 2 Application Example

Note: This is a very simplified example of an application circuit. The function must be verified in the real application.

Table 2 Bill of Material

Reference	Value	Purpose
C <sub>VS</sub>	10 nF / min. 100V	Reduction of voltage spikes. It is mandatory to place this component to assure correct device behavior.
C <sub>EXT</sub>	10 μF	BTS6110-1SJA energy reservoir during ON state. It is mandatory to place this component to assure correct device behavior.

## 4 Pin Configuration

### 4.1 Pin Assignment

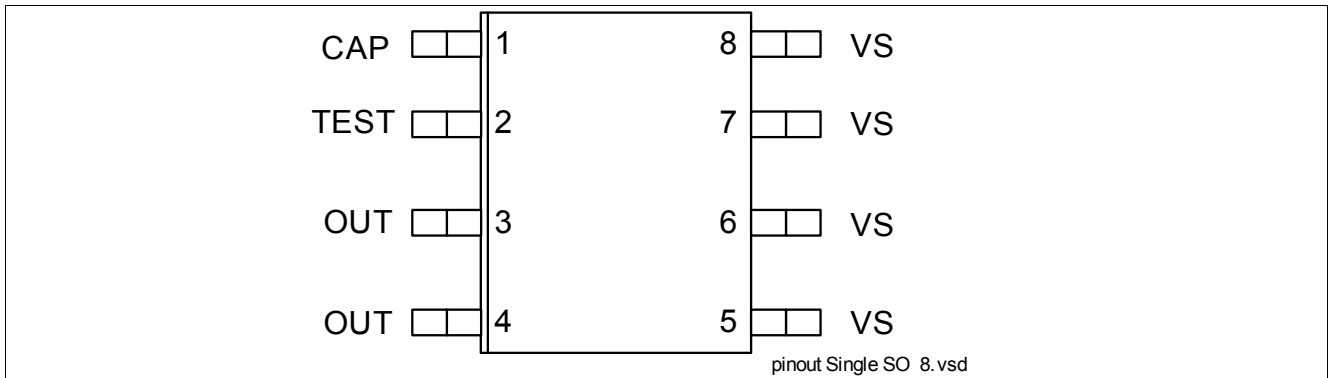

Figure 3 Pin Configuration

### 4.2 Pin Definitions and Functions

Pin	Symbol	Function
1	CAP	<b>CAPacitor</b> ; Must be connected to OUT via a reservoir capacitor
2	TEST	<b>TEST MODE PIN</b> ; Must be connected to OUT
3, 4	OUT	<b>OUTput</b> ; Protected high side power output channel <sup>1)</sup>
5, 6, 7, 8	V <sub>S</sub>	<b>Voltage Supply</b> ; Battery voltage

1) All output pins must be connected together on the PCB. PCB traces have to be designed to withstand the maximum current which can flow.

### 4.3 Voltage and Current Definition

Figure 4 shows all terms used in this document, with associated convention for positive values.

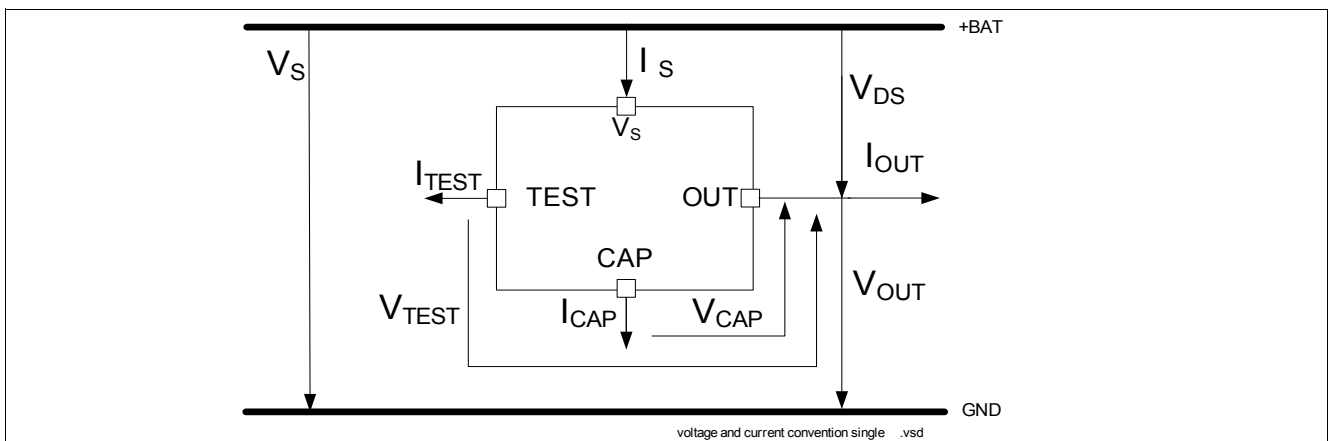

Figure 4 Voltage and Current Definition

## 5 General Product Characteristics

### 5.1 Absolute Maximum Ratings

**Table 3 Absolute Maximum Ratings <sup>1)</sup>**
 $T_J = -40\text{ °C}$  to  $+150\text{ °C}$ ; (unless otherwise specified)

Parameter	Symbol	Values			Unit	Note / Test Condition	Number
		Min.	Typ.	Max.			
<b>Supply Voltages</b>							
Supply voltage	$V_S$	-0.3	–	18	V	–	P_5.1.1
Reverse polarity voltage	$-V_{S(REV)}$	0	–	16	V	$t < 120\text{ s}$ $T_A = 25\text{ °C}$ $R_L \geq 6\ \Omega$	P_5.1.2
Supply voltage for Load dump protection	$V_{S(LD)}$	–	–	65	V	<sup>2)</sup> $R_1 = 2\ \Omega$ $R_L = 6\ \Omega$	P_5.1.3
<b>CAP Pin</b>							
Voltage at CAP pin	$V_{CAP}$	-0.3	–	8.0	V	–	P_5.1.4
Current through CAP pin	$I_{CAP}$	-2	–	15	mA	–	P_5.1.5
<b>TEST Pin</b>							
Voltage at TEST pin	$V_{TEST}$	-0.3	–	1	V	–	P_5.1.6
Current through TEST pin	$I_{TEST}$	-2	–	2	mA	–	P_5.1.7
<b>Power Stage</b>							
Load current	$ I_L $	–	–	$I_{L(LIM)}$	A	–	P_5.1.8
Power dissipation (50% duty cycle)	$P_{TOT}$	–	–	1.4	W	$T_A = 85\text{ °C}$ $T_J < 150\text{ °C}$	P_5.1.9
Voltage at power transistor	$V_{DS}$	–	–	65	V	–	P_5.1.10
<b>Temperatures</b>							
Junction temperature	$T_J$	-40	–	150	°C	–	P_5.1.11
Storage temperature	$T_{STG}$	-55	–	150	°C	–	P_5.1.12
<b>ESD Susceptibility</b>							
ESD susceptibility (all pins)	$V_{ESD}$	-2	–	2	kV	<sup>3)</sup> HBM	P_5.1.13
ESD susceptibility (OUT versus VS)	$V_{ESD}$	-4	–	4	kV	<sup>3)</sup> HBM	P_5.1.14

1) Not subject to production test. Specified by design.

 2)  $V_{S(LD)}$  is setup without the DUT connected to the generator per ISO 7637-1.

3) ESD susceptibility HBM according to EIA/JESD 22-A 114B

#### Notes

- Stresses above the ones listed here may cause permanent damage to the device. Exposure to absolute maximum rating conditions for extended periods may affect device reliability.
- Integrated protection functions are designed to prevent IC destruction under fault conditions described in the data sheet. Fault conditions are considered as “outside” normal operating range. Protection functions are not designed for continuous repetitive operation.

## 5.2 Functional Range

**Table 4 Functional Range  $T_J = -40\text{ °C}$  to  $+150\text{ °C}$ ; (unless otherwise specified)**

Parameter	Symbol	Values			Unit	Note / Test Condition	Number
		Min.	Typ.	Max.			
Nominal operating voltage	$V_{NOM}$	9	13.5	16	V	$V_{OUT} = 0\text{ V}$	P_5.2.1
Extended operating voltage	$V_{S(OP)}$	8	–	24	V	<sup>1)</sup> 8 to 18 V: $R_L = 6\ \Omega$ , 18 to 24 V: $R_L = 12\ \Omega$ $V_{DS} < 0.7\text{ V}$	P_5.2.2

1) Not subject to production test. Specified by design.

*Note: Within the functional range the IC operates as described in the circuit description. The electrical characteristics are specified within the conditions given in the related electrical characteristics table.*

## 5.3 Thermal Resistance

**Table 5 Thermal Resistance**

Parameter	Symbol	Values			Unit	Note / Test Condition	Number
		Min.	Typ.	Max.			
Junction to case (bottom)	$R_{thJS}$	–	40	–	K/W	<sup>1)</sup>	P_5.3.1
Junction to ambient	$R_{thJA}$	–	58	–	K/W	<sup>1) 2)</sup>	P_5.3.2

1) Not subject to production test. Specified by design.

2) Specified  $R_{thja}$  value is according to JEDEC JESD51-2,-5,-7 at natural convection on FR4 2s2p board with thermal vias; The product (chip + package) was simulated on a 76.4 x 114.3 x 1.5 mm board with 2 inner copper layers (2 x 70µm Cu, 2 x 35 µm Cu).

### 5.3.1 PCB set up

$e = 1.27$ ;  $A = 5.69$ ;  $L = 1.31$ ;  $B = 0.65$

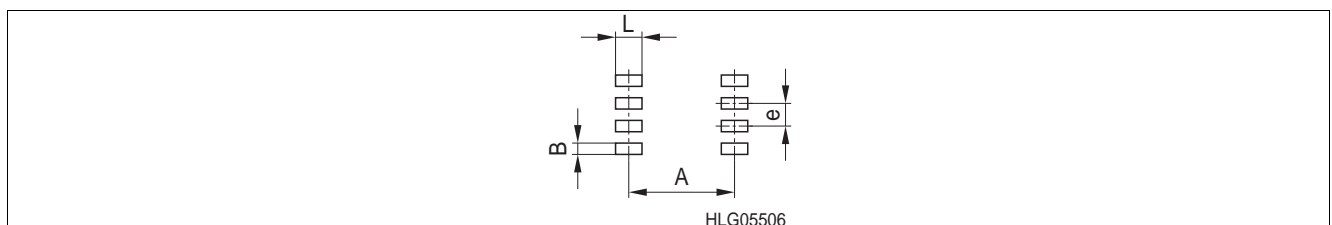

**Figure 5 PCB Footprint for PG-DSO-8-49**

### 5.3.2 Thermal Resistance

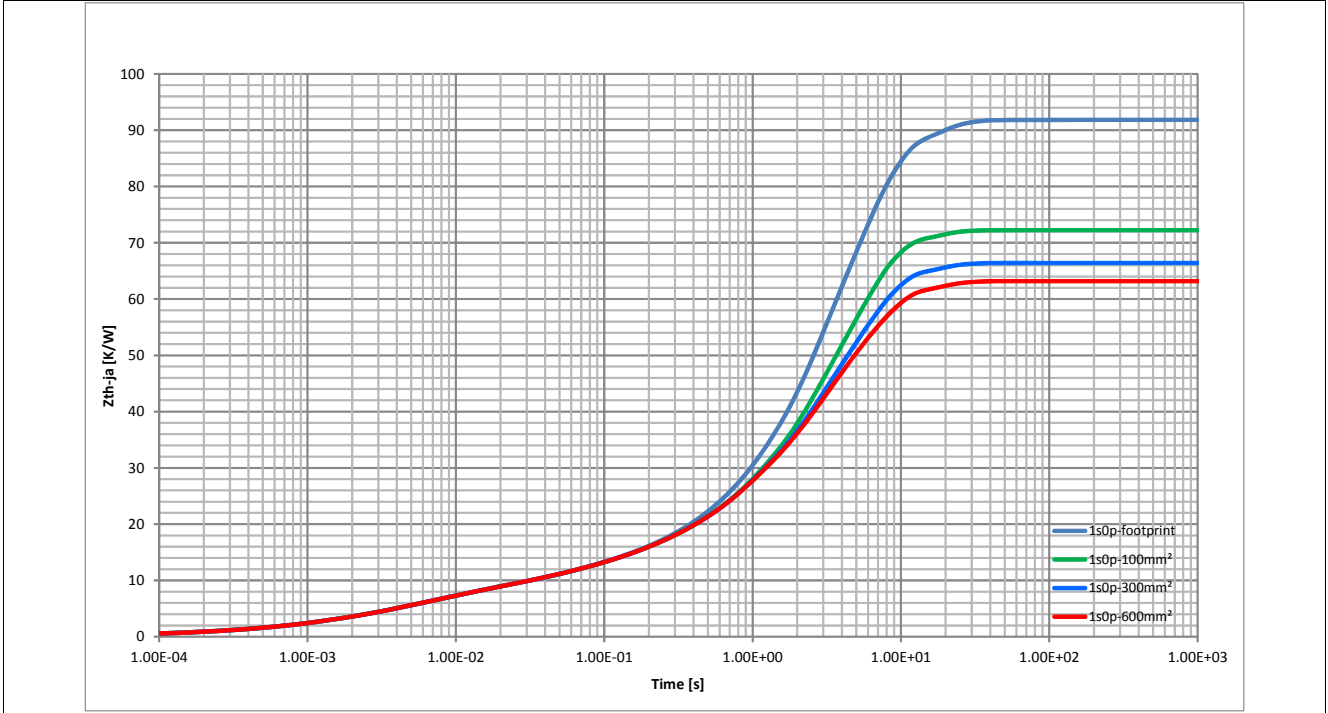

Figure 6 Typical Thermal Resistance for FR2 PCB

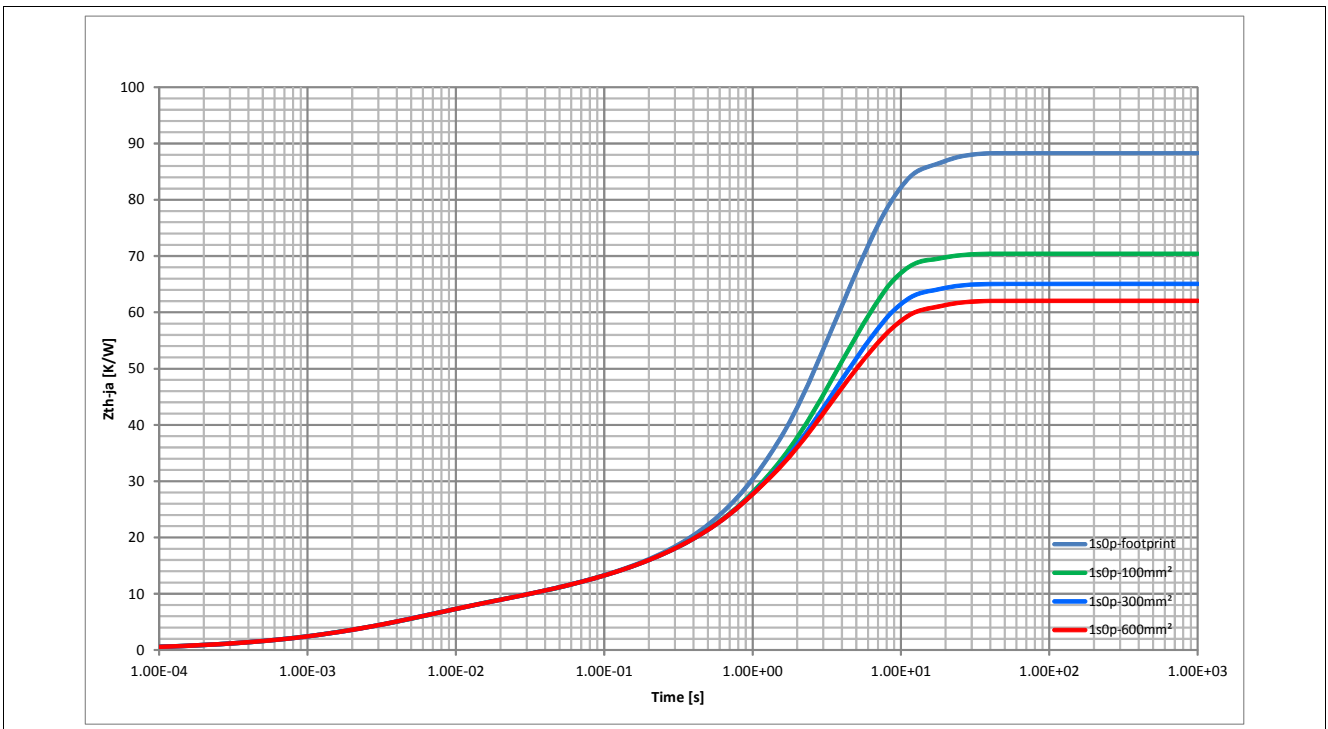

Figure 7 Typical Thermal Resistance for FR4 PCB

## 6 Power Stage

The power stage is built using an N-channel vertical power MOSFET (DMOS) with charge pump.

### 6.1 Output ON-state Resistance

The ON-state resistance  $R_{DS(ON)}$  depends on the junction temperature  $T_J$ . **Figure 8** shows the dependencies in terms of temperature for the typical ON-state resistance. The behavior in reverse polarity is described in **Chapter 7.2**.

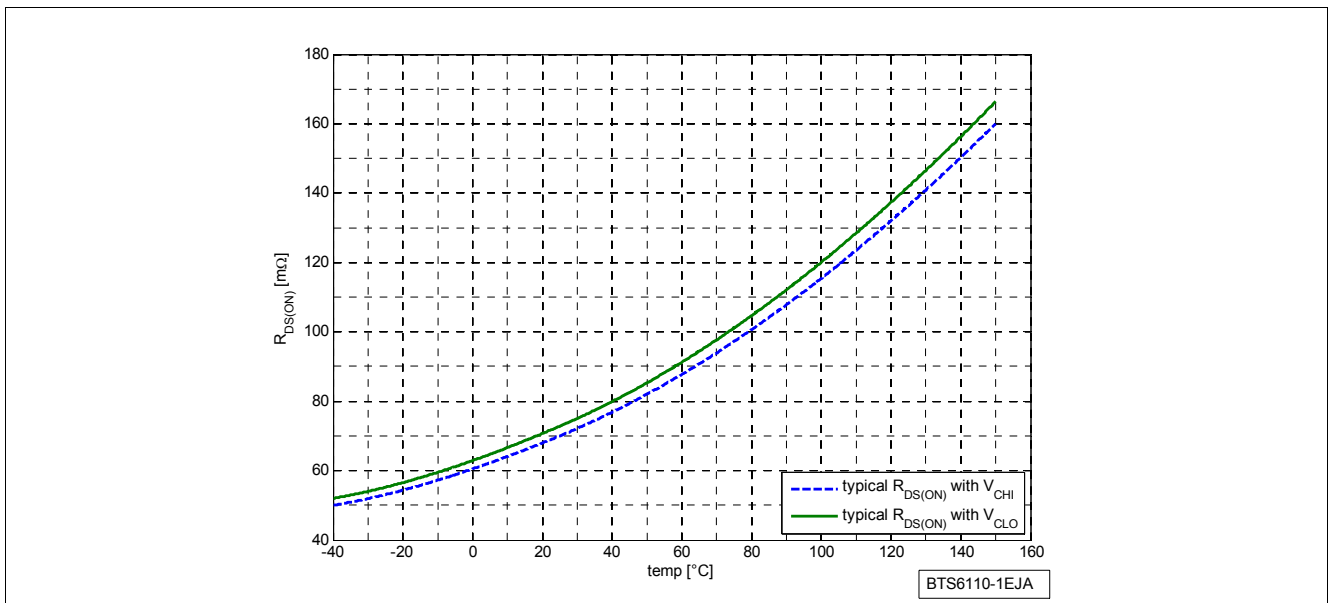
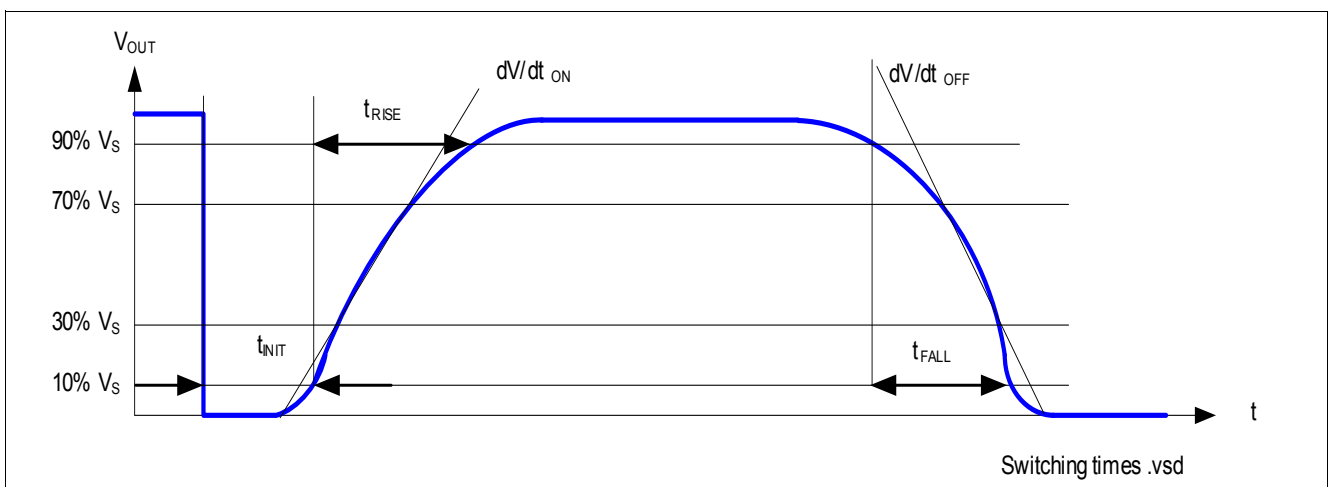

**Figure 8** Typical ON-state Resistance

### 6.2 Turn ON/OFF Characteristics with Resistive Load

A low voltage event at the OUT pin causes the power DMOS to switch ON with a dedicated slope, optimized in terms of Electro Magnetic Emission.

**Chapter 7.2** shows the typical timing when switching a resistive load.



**Figure 9** Switching a Resistive Load Timing

### 6.3 Frequency Generator

The BTS6110-1SJA is designed to manage side indicators functionality. As soon as a LOW voltage level is applied for more than  $t_{INIT}$ , at OUT pin, the clock generator is activated and the channel is switched ON. At  $t_1$ , the device starts diagnosis. Refer to **Figure 10**. In case of underload detection, the device switches OFF and operates the failure frequency based on  $T_{2FAIL}$ . Otherwise, the device stays ON and runs on frequency based on  $T_4$ . The duty cycle is fixed to d.

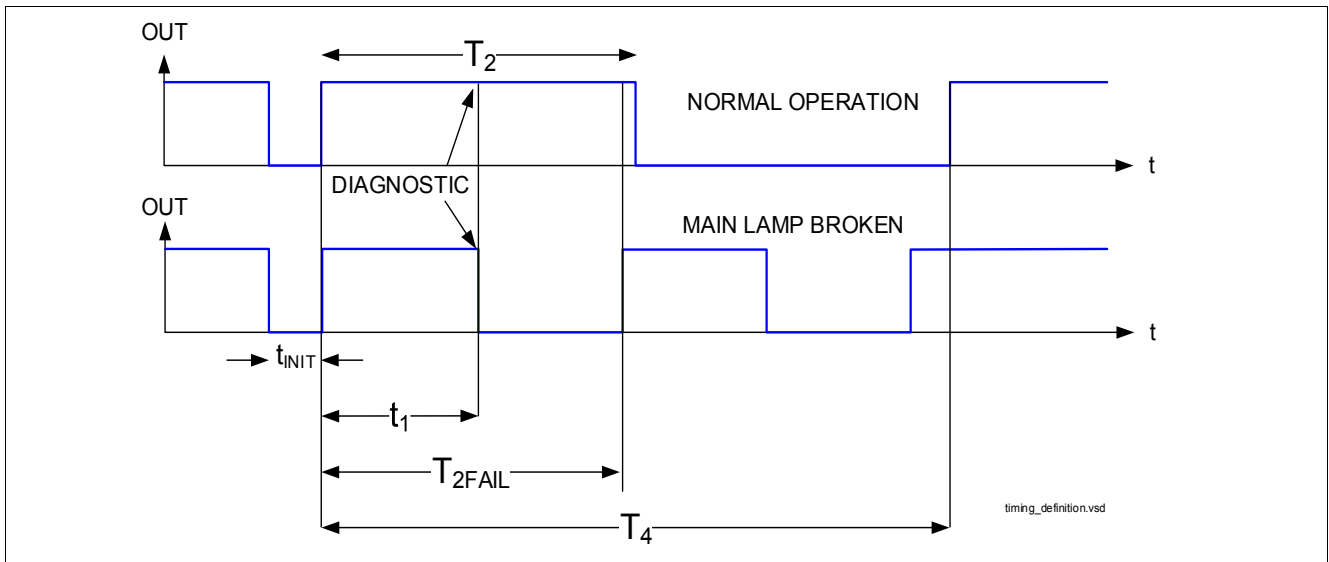

**Figure 10** Frequency Generation Timing

### 6.4 Timing Output

The BTS6110-1SJA is dedicated to side indicators function on vehicle. The frequency  $f_2$  (resp  $T_{2FAIL}$  period) is tuned to be the failure indication frequency. At  $t_1$  time, the BTS6110-1SJA measures the load current. Refer to **Figure 11**. Depending on the measurement results, three possible actions will be done (see **Chapter 8** for the details diagnosis definition).

If an underload is detected, it provokes immediate switch OFF to run at  $f_2$  frequency, indicating the failure. A normal diagnosis keep the power output ON for  $t_1$  to run at  $f_4$  frequency. A short circuit will latch the device.

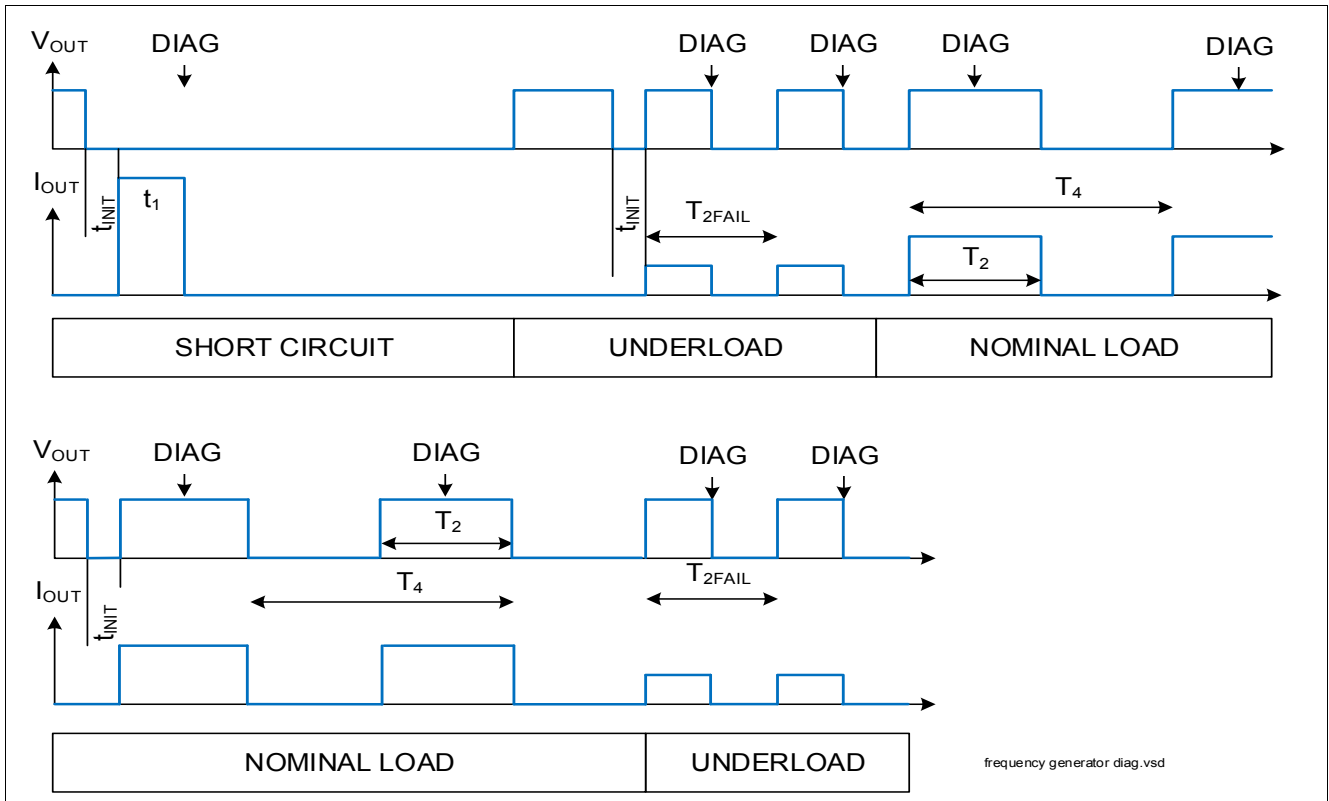
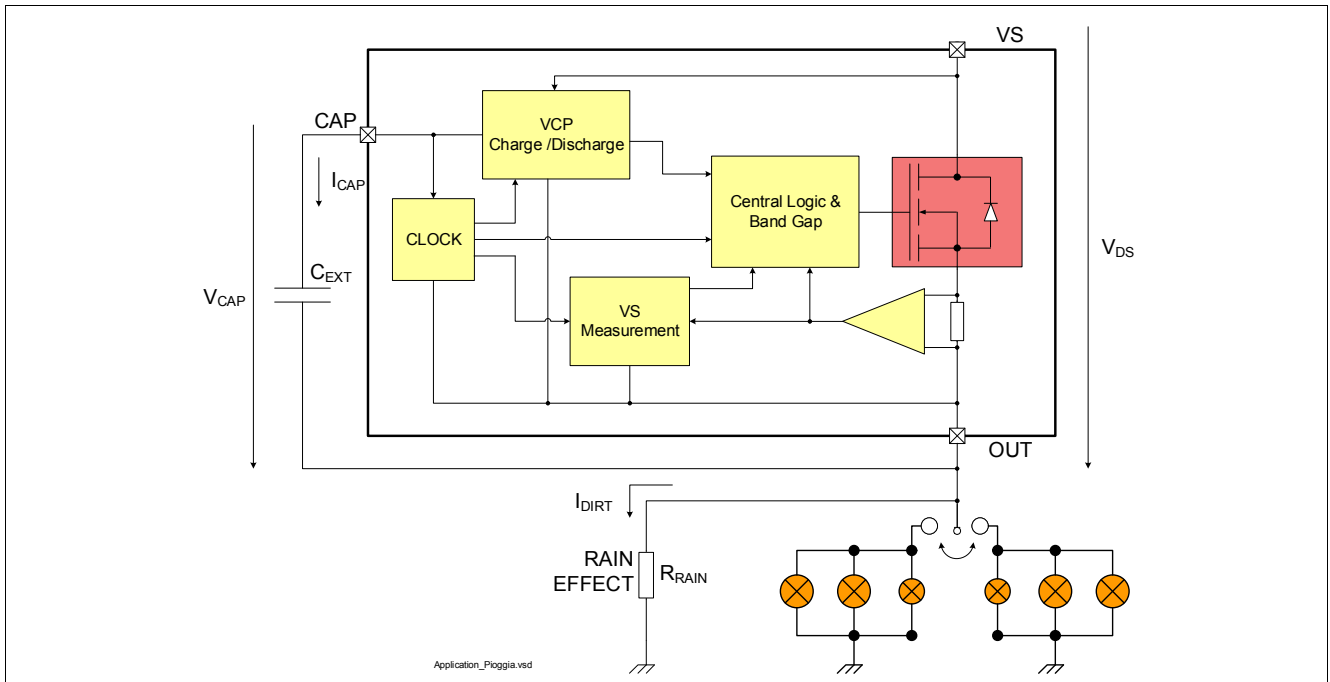

Figure 11 Frequency Generation Timing

### 6.5 Output Polarization

The BTS6110-1SJA includes from  $V_S$  to OUT a pull up resistor  $R_{L(OFF)}$ . This pull-up resistor compensates the  $I_{DIRT}$  leakage current due to the humidity and dust at the handle bar selector. It forces supply voltage VS at the output until a load is connected. The BTS6110-1SJA starts as soon as  $V_{DS}$  is detected between  $V_S$  and OUT by charging the external reservoir capacitor  $C_{EXT}$ . Refer to [Figure 12](#).



**Figure 12 Output Polarization Circuitry**

In case of leakage at the output, due to rain for example, the BTS6110-1SJA might start parasitically. To limit the effect, a load current measurement is implemented to estimate the impedance connected at the output. An impedance lower than  $R_{RAIN}$  will activate the switch while an impedance above (see maximum value P\_9.1.11) will keep the device in sensing mode. Refer to [Figure 13](#).

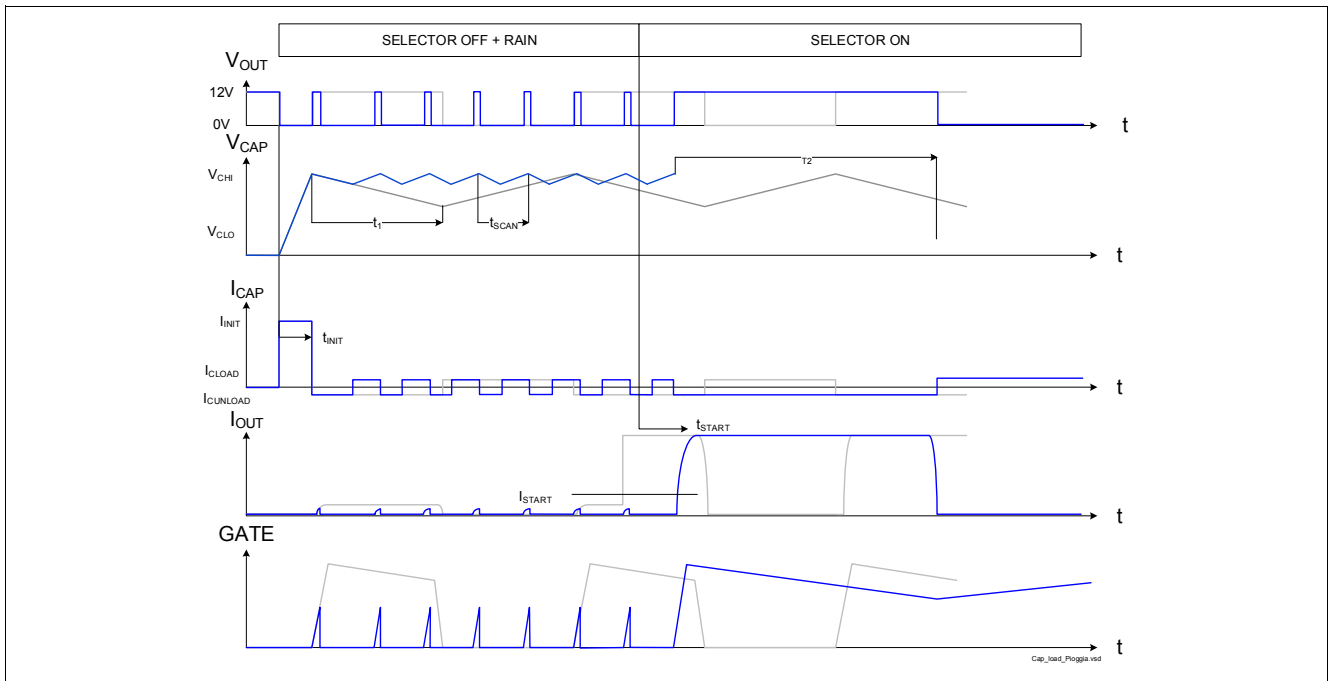

**Figure 13 Output Timing during Leakage**

### 6.6 CAP Pin

The BTS6110-1SJA stores the needed energy to keep the DMOS ON during  $T_2$  phase, in the capacitor  $C_{EXT}$ . This capacitor is loaded initially with  $I_{INIT}$  while OUT is grounded.  $I_{INIT}$  is relatively important to reduce  $t_{INIT}$ , initialization time. During the next successive activations, the charging / discharging currents are controlled to  $I_{CLOAD}$  and  $I_{CUNLOAD}$  whom are significantly lower to improve EMC and capacitor aging.

The loading is stopped when the voltage at the capacitor  $V_{CHI}$  is reached, and restarted by  $V_{CLO}$ . This oscillation provides the reference clock to the flasher functionality. In the case  $V_S - V_{OUT}$  is below  $V_{S(OP)}$ , the device doesn't start. Refer from [Equation \(1\)](#) to [Equation \(4\)](#) and [Figure 14](#) and [Figure 15](#).

$$t_{INIT} = C_{EXT} \times \frac{V_S - 1V}{I_{INIT}} \times \ln\left(\frac{V_S - 1V}{V_S - 7,5V}\right) \tag{1}$$

$$T_{2FAIL} = T_4 \times d_f \tag{2}$$

$$d = \frac{T_2}{T_4} = \frac{1}{1 + \frac{I_{CUNLOAD}}{I_{CLOAD}}} \tag{3}$$

$$T_4 = C_{EXT} \times R_{CAP} \tag{4}$$

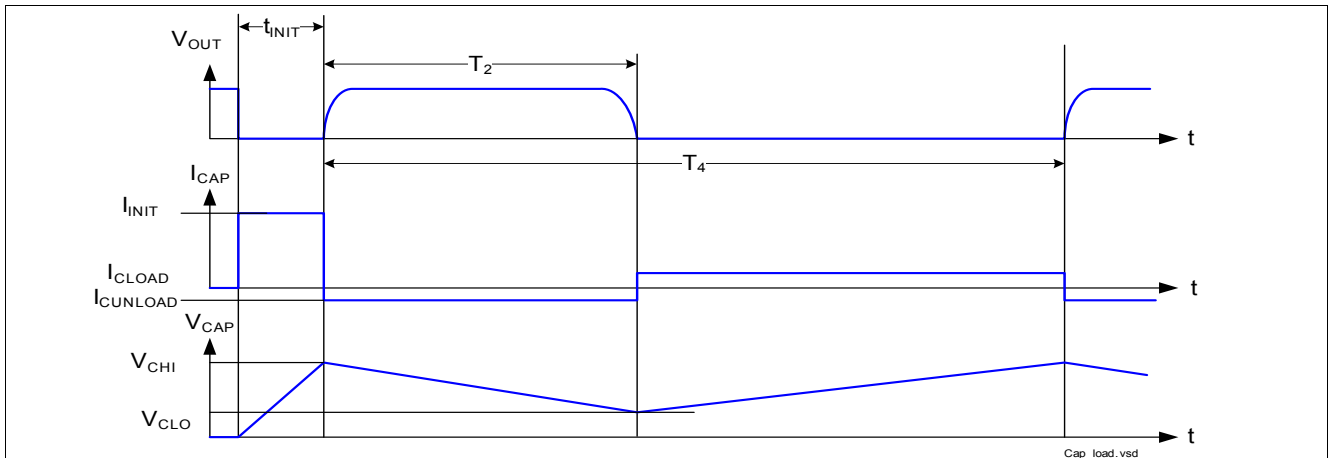

Figure 14 Capacitor Charge and Discharge Timing

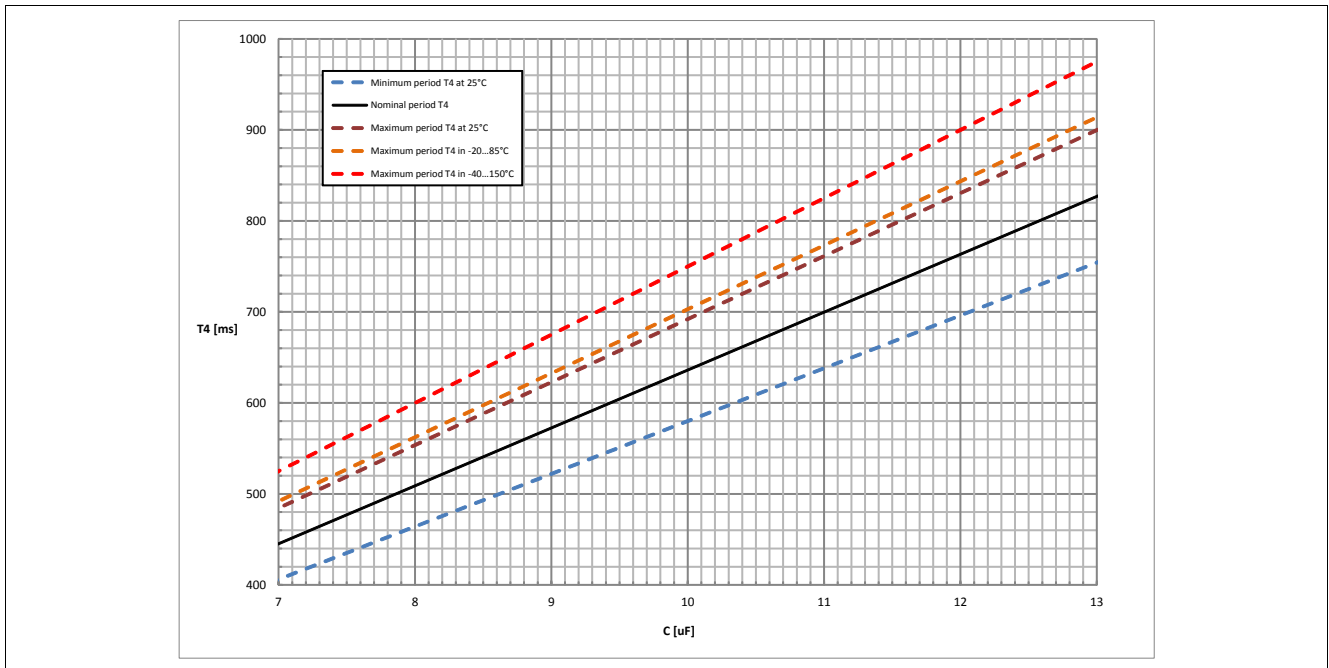

Figure 15 Normal Period T4 Dependency in Regards to Capacitor Value (typical behavior)

## 7 Protection Functions

The BTS6110-1SJA provides integrated protection functions. These functions are designed to prevent the destruction of the IC from fault conditions described in the data sheet. Fault conditions are considered as “outside” normal operating range. Protection functions are designed for neither continuous nor repetitive operation.

### 7.1 Overvoltage Protection

The BTS6110-1SJA is protected against overvoltage. In case of a voltage  $V_S > V_{S(AZ)}$ , if the handle bar selector switch is ON, the  $Z_{DS(AZ)}$  will activate the power DMOS and some current will flow, limited by the load.

### 7.2 Reverse Polarity Protection

In case of reverse polarity, the intrinsic body diodes of the power DMOS causes power dissipation. The current in this intrinsic body diode is limited by the load itself. [Figure 16](#) shows the application schematic.

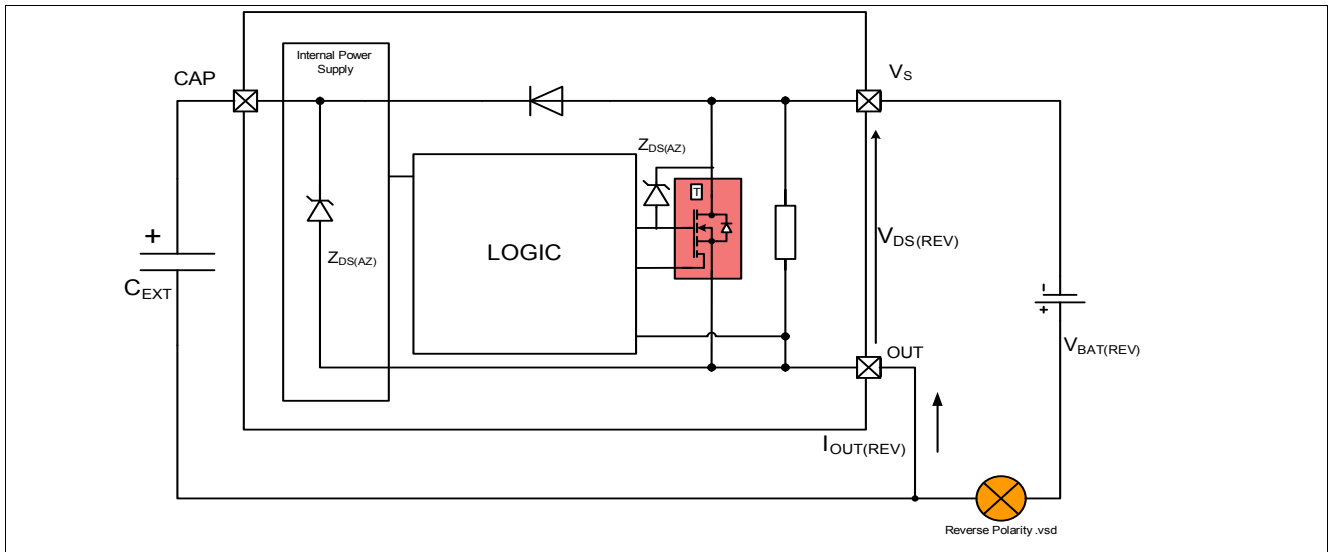

Figure 16 Reverse Polarity Protection

### 7.3 Overload Protection

In case of overload, such as high inrush of cold lamp filament, or short circuit to ground, the BTS6110-1SJA offers protection mechanisms.

#### 7.3.1 Current Limitation

At first step, the instantaneous power in the switch is maintained to a safe value by limiting the current to  $I_{L(SC)}$ . During this time, the DMOS temperature is increasing.

#### 7.3.2 Temperature Limitation in the Power DMOS

The channel incorporates an absolute ( $T_{J(SC)}$ ) and a dynamic ( $T_{J(SW)}$ ) temperature sensor. Activation of either sensor will cause the overheated channel to switch OFF to prevent destruction. Any protective switch OFF latches the output until the temperature has reached an acceptable value. To ensure the lamps to be turned ON, the DMOS restarts after cool down until  $t_1$ . **Figure 17** sketches the situation. The restart takes place for maximum  $t_1$  of the flasher in fault condition, around 130ms. If after this time, the device is still in restart conditions, the switch is latched until the OUT voltage goes to HIGH again.

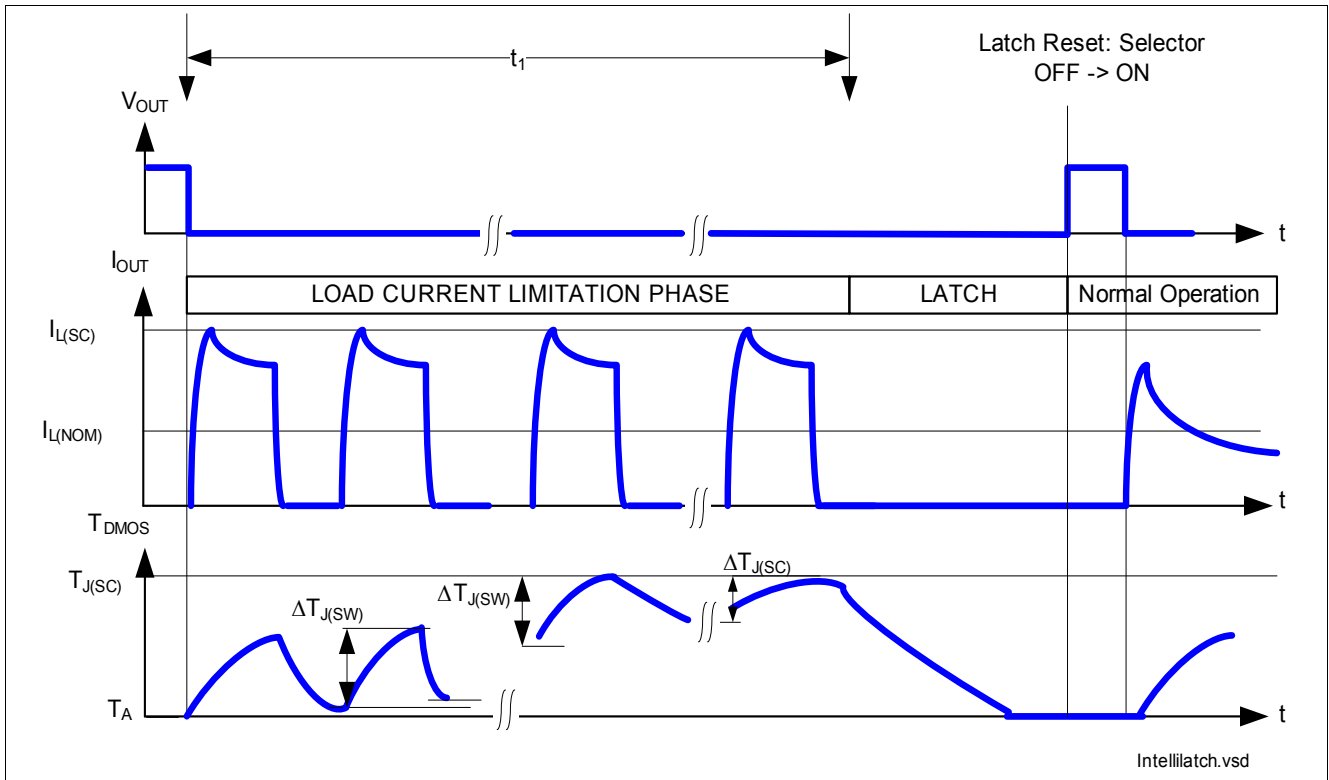

Figure 17 Overload Protection

## 8 Diagnostic Functions

For diagnosis purpose, the BTS6110-1SJA measures the load current.

### 8.1 Load Current Measurement

The BTS6110-1SJA integrates a sense signal called  $I_{IS}$ . As long as no “hard” failure mode occurs (current limitation / overtemperature / excessive dynamic temperature increase) a proportional signal to the load current (ratio  $k_{ILIS} = I_L / I_{IS}$ ) is measured. To reduce current consumption, the diagnosis is only realized periodically. Refer to the [Figure 11](#). The complete sense circuit and diagnostic mechanism is described on [Figure 18](#). In the case  $V_{IS} < V_{REF}$ , the device raises an internal fault signal, to double the flashing frequency. Just before the switch ON event, the device measures the supply voltage VS, via a voltage divider.

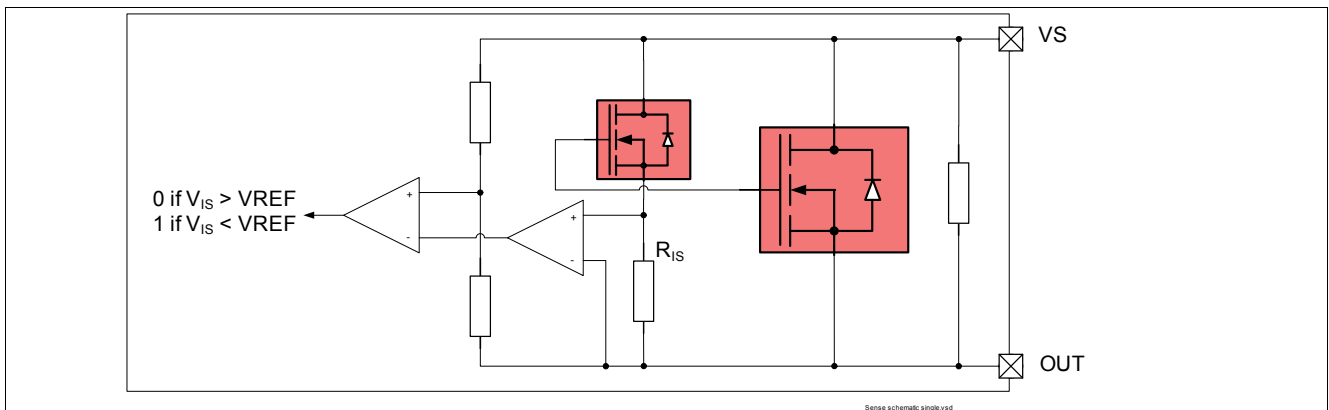

Figure 18 Diagnostic Block Diagram

## 8.2 Under load Current

Figure 19 shows the load current  $I_{df\_L}$  considered as a function of the load current in the power DMOS. The blue curve represents the typical current threshold, assuming ideal device. The red curves show the accuracy the device provide across full temperature range, at a defined current <sup>1)</sup>.

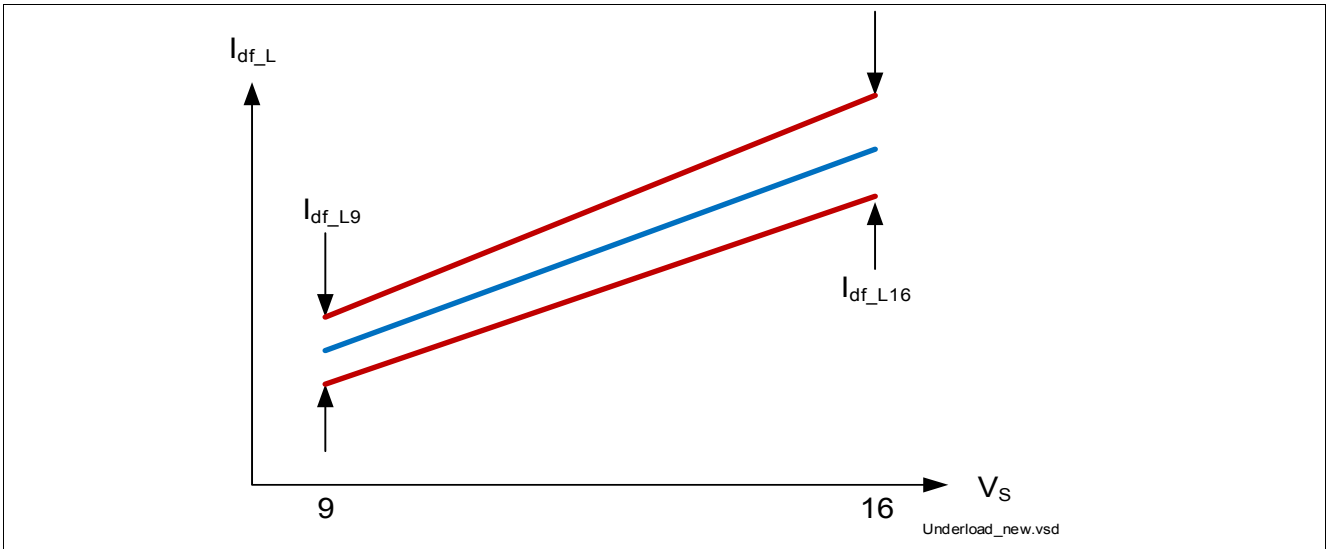

Figure 19 Current Sense for Nominal Load

1) Only  $I_{df\_L9}$  and  $I_{df\_L16}$  are tested in production. The red curves between these points are specified by design.

## 9 Electrical Characteristics

### 9.1 Electrical Characteristics Power Stage

**Table 6 Electrical Characteristics: Power Stage**
 $V_S = 9\text{ V to }16\text{ V}$ ,  $T_J = -40\text{ °C to }+150\text{ °C}$  (unless otherwise specified).

 Typical values are given at  $V_S = 13.5\text{ V}$ ,  $T_J = 25\text{ °C}$ 

Parameter	Symbol	Values			Unit	Note / Test Condition	Number
		Min.	Typ.	Max.			
ON-state resistance per channel	$R_{DS(ON)_150}$	–	–	200	mΩ	$R_L = 6\ \Omega$ $V_{CAP} = V_{CHI}$ $T_J = 150\text{ °C}$ See <a href="#">Figure 8</a>	P_9.1.1
ON-state resistance per channel	$R_{DS(ON)_25}$	–	80	–	mΩ	<sup>1)</sup> $T_J = 25\text{ °C}$	P_9.1.2
Drain to source clamping voltage $V_{DS(AZ)} = [V_S - V_{OUT}]$	$V_{DS(AZ)}$	65	70	75	V	$I_{DS} = 2\text{ mA}$	P_9.1.3
Output Leakage resistor	$R_{RAIN}$	0.04	0.4	1	kΩ	<sup>1)</sup>	P_9.1.11
Slew rate 30% to 70% $V_S$	$dV/dt_{ON}$	0.1	0.25	0.5	V/μs	$R_L = 6\ \Omega$ $V_S = 13.5\text{ V}$ See <a href="#">Figure 9</a>	P_9.1.5
Slew rate 70% to 30% $V_S$	$-dV/dt_{OFF}$	0.1	0.25	0.5	V/μs		P_9.1.6
Turn-ON time to $V_{OUT} = 10$ to 90% $V_S$	$t_{RISE}$	–	70 <sup>1)</sup>	–	μs		P_9.1.7
Turn-OFF time to $V_{OUT} = 90$ to 10% $V_S$	$t_{FALL}$	–	70 <sup>1)</sup>	–	μs		P_9.1.8
Switch ON energy	$E_{ON}$	–	450	–	μJ	<sup>1)</sup> $R_L = 6\ \Omega$ $V_{OUT} = 90\% V_S$ $V_S = 16\text{ V}$	P_9.1.9
Switch OFF energy	$E_{OFF}$	–	470	–	μJ	<sup>1)</sup> $R_L = 6\ \Omega$ $V_{OUT} = 10\% V_S$ $V_S = 16\text{ V}$	P_9.1.10

<sup>1)</sup> Not subject to production test, specified by design

## 9.2 Electrical Characteristics CAP pin

**Table 7 Electrical Characteristics: CAP pin**
 $V_S = 9\text{ V to }16\text{ V}$ ,  $T_J = -40\text{ °C to }+150\text{ °C}$  (unless otherwise specified).

 Typical values are given at  $V_S = 13.5\text{ V}$ ,  $T_J = 25\text{ °C}$ 

Parameter	Symbol	Values			Unit	Note / Test Condition	Number
		Min.	Typ.	Max.			
<b>Load Current</b>							
Initialization Load current	$I_{INIT}$	3	4.5	10	mA	See <a href="#">Figure 14</a> $V_S = 9\text{ V}$	P_9.2.1
Charging current	$I_{CLOAD}$		76.4		$\mu\text{A}$	<sup>1)</sup> See <a href="#">Figure 14</a> $V_{CAP} = 5.37\text{ V}$	P_9.2.2
Discharging current	$I_{CUNLOAD}$		-74.4		$\mu\text{A}$	<sup>1)</sup> See <a href="#">Figure 14</a> $V_{CAP} = 5.37\text{ V}$	P_9.2.3
Load current matching	$I_{CRATIO} = \frac{ I_{CUNLOAD} }{I_{CLOAD}}$		0.97		–	<sup>1)</sup> See <a href="#">Figure 14</a>	P_9.2.4
<b>Voltage Threshold</b>							
CAP voltage High threshold	$V_{CHI}$		6.4		V	<sup>1)</sup> See <a href="#">Figure 14</a>	P_9.2.5
CAP voltage Low threshold	$V_{CLO}$		4		V	<sup>1)</sup> See <a href="#">Figure 14</a>	P_9.2.6
CAP voltage diagnostic threshold	$V_{CDIAG}$		5.37		V	<sup>1)</sup> See <a href="#">Figure 14</a>	P_9.2.7
CAP voltage threshold Matching	$V_{OSC} = V_{CHI} - V_{CLO}$		2.4		V	<sup>1)</sup> See <a href="#">Figure 14</a>	P_9.2.8
Flasher duty cycle Device dependency	$R_{LOAD} = \frac{V_{OSC}}{I_{CLOAD}}$	–	32	–	k $\Omega$	<sup>1)</sup> See <a href="#">Figure 14</a>	P_9.2.10
Flasher duty cycle Device dependency	$R_{UNLOAD} = \frac{V_{OSC}}{I_{CUNLOAD}}$	–	31.6	–	k $\Omega$	<sup>1)</sup> See <a href="#">Figure 14</a>	P_9.2.11
Flasher duty cycle Device dependency	$R_{CAP} = R_{UNLOAD} + R_{LOAD}$	58	63.6	75	k $\Omega$		P_9.2.17
Flasher duty cycle Device dependency	$R_{CAP\_USAGE}$	58	63.6	70.3	k $\Omega$	<sup>1) 2)</sup> $T_J = -20\text{ °C to }85\text{ °C}$	P_9.2.19
Flasher duty cycle Device dependency	$R_{CAP\_AMB}$	58	63.6	69.2	k $\Omega$	<sup>1) 2)</sup> $T_J = +25\text{ °C}$	P_9.2.20
<b>Time Generator</b>							
Duty Cycle	d	45	50	55	%	–	P_9.2.14
Double frequency factor	$df = \frac{T_{2FAIL}}{T_4}$	0.40	0.45	0.50	–	–	P_9.2.18
Initialisation Time	$t_{INIT}$	–	30	–	ms	– <sup>1) 2)</sup> $V_S = 9\text{ V}$	P_9.2.13
Impedance sensing Time	$t_{SCAN}$	–	25	–	ms	– <sup>1) 2)</sup>	P_9.2.16

1) Not subject to production test, specified by design

 2) With a CEXT of 10  $\mu\text{F}$

### 9.3 Electrical Characteristics for the Protection Functions

**Table 8 Electrical Characteristics: Protection**
 $V_S = 9\text{ V to }16\text{ V}$ ,  $T_J = -40\text{ °C to }+150\text{ °C}$  (unless otherwise specified).

 Typical values are given at  $V_S = 13.5\text{ V}$ ,  $T_J = 25\text{ °C}$ 

Parameter	Symbol	Values			Unit	Note / Test Condition	Number
		Min.	Typ.	Max.			
<b>Reverse Polarity</b>							
Drain source diode voltage during reverse polarity	$V_{DS(REV)}$	200	600	700	mV	$R_L = 6\ \Omega$ $T_J = 150\text{ °C}$ See <a href="#">Figure 16</a>	P_9.3.1
<b>Overload Condition</b>							
Load current limitation	$I_{L(SC)}$	20	27	36	A	<sup>1)</sup> $V_{DS} = 5\text{ V}$	P_9.3.2
Dynamic temperature increase while switching	$\Delta T_{J(SW)}$	–	80	–	K	<sup>2)</sup> See <a href="#">Figure 17</a>	P_9.3.5
Thermal shutdown temperature	$T_{J(SC)}$	150	170 <sup>2)</sup>	200 <sup>2)</sup>	°C	See <a href="#">Figure 17</a>	P_9.3.3
Thermal shutdown hysteresis	$\Delta T_{J(SC)}$	–	30	–	K	<sup>2)</sup> See <a href="#">Figure 17</a>	P_9.3.4

 1) Test at  $T_J = -40\text{ °C}$  only

2) Not subject to production test, specified by design.

## 9.4 Electrical Characteristics Diagnostic Function

**Table 9 Electrical Characteristics: Diagnostics**

$V_S = 9\text{ V}$  to  $16\text{ V}$ ,  $T_J = -40\text{ °C}$  to  $+150\text{ °C}$  (unless otherwise specified).

Typical values are given at  $V_S = 13.5\text{ V}$ ,  $T_J = 25\text{ °C}$

Parameter	Symbol	Values			Unit	Note / Test Condition	Number
		Min.	Typ.	Max.			
<b>Load Current Underload Threshold</b>							
Load current threshold Low battery operation	Idf_L9	0.782	0.924	1.067	A	$V_S$ at 9 V step See <a href="#">Figure 19</a>	P_9.4.1
Load current threshold High battery operation	Idf_L16	1.074	1.269	1.464	A	$V_S$ at 16 V step See <a href="#">Figure 19</a>	P_9.4.2

## 10 Package Outlines

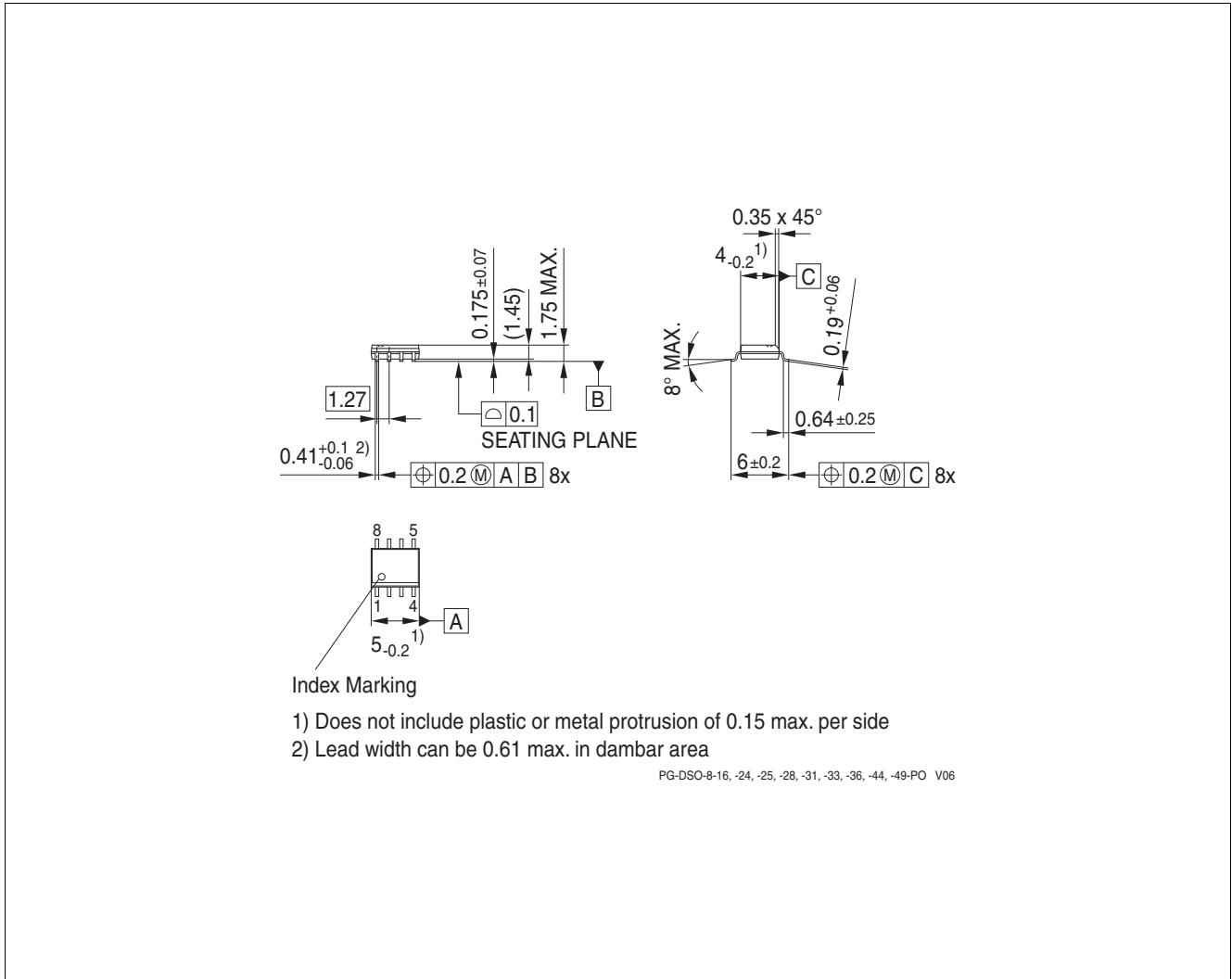

**Figure 20** PG-DSO-8-49 (Plastic Dual Small Outline Package) (RoHS-Compliant)

### Green Product (RoHS compliant)

To meet the world-wide customer requirements for environmentally friendly products and to be compliant with government regulations the device is available as a green product. Green products are RoHS-Compliant. For the soldering of this device the appropriate temperature profile as described in J-STD-020 is to be used.

**Table 10** Package Classification

Value	Purpose
MSL3	JEDEC humidity category acc. J-STD-020-D
260°C	JEDEC classification temperature acc. J-STD-020-D

## 11 Revision History

Version	Date	Changes
1.1	2014-11-24	<p>Chapter 3 - Changed position of the Notes</p> <p>Chapter 5.3 - Removed the hint for exposed pad packages in footnote of table 5</p> <p>Chapter 6.3 - Minor text change and update of Figure 10</p> <p>Chapter 6.4 - Minor text change and update of Figure 11</p> <p>Chapter 6.5 - Typo in text and update of Figure 12 and 13 (typo and headline)</p> <p>Chapter 7.3.2 - Typo in text corrected</p> <p>Chapter 8.2 - Update of Figure 19</p> <p>Chapter 9.2 - P_9.2.2 and P_9.2.3 changed test condition from <math>V_{CAP} - V_{OUT} = 5.37\text{ V}</math> to <math>V_{CAP} = 5.37\text{ V}</math></p> <p>Chapter 10 - Updated package drawing Figure 20</p>
1.0	2014-02-27	Creation of the Document

**Edition 2014-11-24**

**Published by  
Infineon Technologies AG  
81726 Munich, Germany**

**© 2014 Infineon Technologies AG  
All Rights Reserved.**

### **Legal Disclaimer**

The information given in this document shall in no event be regarded as a guarantee of conditions or characteristics. With respect to any examples or hints given herein, any typical values stated herein and/or any information regarding the application of the device, Infineon Technologies hereby disclaims any and all warranties and liabilities of any kind, including without limitation, warranties of non-infringement of intellectual property rights of any third party.

### **Information**

For further information on technology, delivery terms and conditions and prices, please contact the nearest Infineon Technologies Office ([www.infineon.com](http://www.infineon.com)).

### **Warnings**

Due to technical requirements, components may contain dangerous substances. For information on the types in question, please contact the nearest Infineon Technologies Office.

Infineon Technologies components may be used in life-support devices or systems only with the express written approval of Infineon Technologies, if a failure of such components can reasonably be expected to cause the failure of that life-support device or system or to affect the safety or effectiveness of that device or system. Life support devices or systems are intended to be implanted in the human body or to support and/or maintain and sustain and/or protect human life. If they fail, it is reasonable to assume that the health of the user or other persons may be endangered.