

# HITFET™+ 24V

## BTT3018EJ Smart Low-Side Power Switch



### Features

- Single channel device optimized for 24 V applications
- Electrostatic discharge protection (ESD)
- Over current, active clamping and over temperature protection
- Over temperature latch shutdown
- Supply pin undervoltage protection
- Dedicated status signal
- Slew-rate control to adjust switching speed
- PWM switching capability of 20KHz (duty cycle 10%-90%)
- Green Product (RoHS compliant)
- AEC Qualified

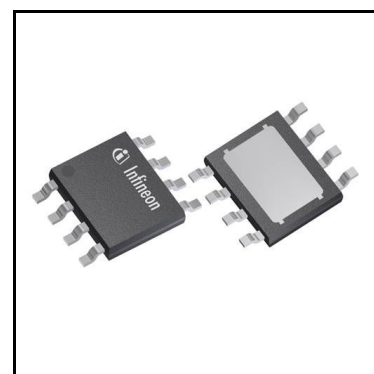

### Potential applications

- Suitable for resistive and inductive loads

### Product validation

Qualified for automotive applications. Product validation according to AEC-Q100/101.

### Description

The BTT3018EJ is a 16 mΩ single channel Smart Low-Side Power Switch within a PG-TDSO-8 package providing embedded protective functions. The power transistor is built by a N-channel vertical power MOSFET. The BTT3018EJ is monolithically integrated.

The BTT3018EJ is automotive qualified and is optimized for 24 V automotive applications.

**Table 1 Product Summary**

Parameter	Symbol	Values
Operating Voltage Range	$V_{OUT}$	0 ... 36 V
Maximum load voltage	$V_{BAT(OUT)}$	63 V
ON-State Resistance	$R_{DS(ON)_25}$	16 mΩ
Nominal Load Current	$I_{L(NOM)}$	7.0 A
Minimum Current Limitation	$I_{L(LIM)}$	30 A

<b>Type</b>	<b>Package</b>	<b>Marking</b>
BTT3018EJ	PG-TDSO-8	T3018EJ

## Table of Contents

<b>1</b>	<b>Block Diagram</b> .....	<b>5</b>
<b>2</b>	<b>Pin Configuration</b> .....	<b>6</b>
2.1	Pin Assignment .....	6
2.2	Pin Definitions and Functions .....	6
2.3	Voltage and Current Definition .....	7
<b>3</b>	<b>General Product Characteristics</b> .....	<b>8</b>
3.1	Absolute Maximum Ratings .....	8
3.2	Functional Range .....	9
3.3	Thermal Resistance .....	10
3.4	Transient Thermal Impedance .....	10
<b>4</b>	<b>Power Stage</b> .....	<b>11</b>
4.1	Output On-state Resistance .....	11
4.2	Resistive Load Output Timing .....	12
4.3	Adjustable switching speed / Slew rate .....	12
4.3.1	Output Clamping .....	14
4.3.2	Maximum Load Inductance .....	14
4.4	Reverse Current Capability .....	15
4.5	Characteristics .....	15
<b>5</b>	<b>Supply and Input Stage</b> .....	<b>16</b>
5.1	Supply Circuit .....	16
5.1.1	Undervoltage Shutdown .....	16
5.1.2	Supply current consumption .....	16
5.2	Characteristics .....	17
<b>6</b>	<b>Protection Functions</b> .....	<b>18</b>
6.1	Over Voltage Clamping on Output .....	18
6.2	Thermal Protection .....	18
6.3	Overcurrent Limitation / Short Circuit Behavior .....	18
6.4	Reset latch condition .....	18
6.5	Characteristics .....	20
<b>7</b>	<b>Diagnostics</b> .....	<b>21</b>
7.1	Functional Description of the STATUS Pin .....	21
7.2	Characteristics .....	22
<b>8</b>	<b>Electrical Characteristics</b> .....	<b>23</b>
8.1	Power Stage .....	23
8.2	Protection .....	25
8.3	Supply and Input Stage .....	26
8.4	Diagnostics .....	28
<b>9</b>	<b>Characterisation Results</b> .....	<b>30</b>
9.1	Power Stage .....	30
9.2	Protection .....	34
9.3	Supply and Input Stage .....	35
<b>10</b>	<b>Application Information</b> .....	<b>38</b>
10.1	Layout recommendations/considerations .....	38

10.2	Application Diagrams .....	38
<b>11</b>	<b>Package Outlines .....</b>	<b>40</b>
<b>12</b>	<b>Revision History .....</b>	<b>41</b>

Block Diagram

# 1 Block Diagram

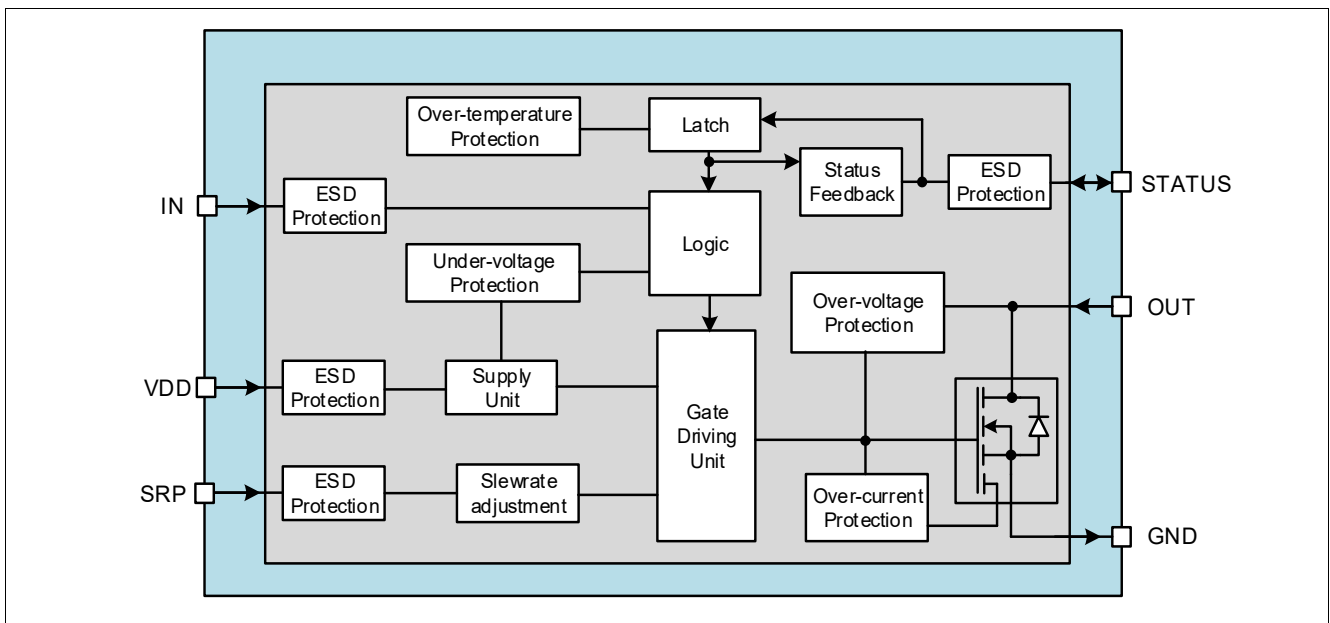

Figure 1 Block Diagram of the BTT3018EJ

Pin Configuration

## 2 Pin Configuration

### 2.1 Pin Assignment

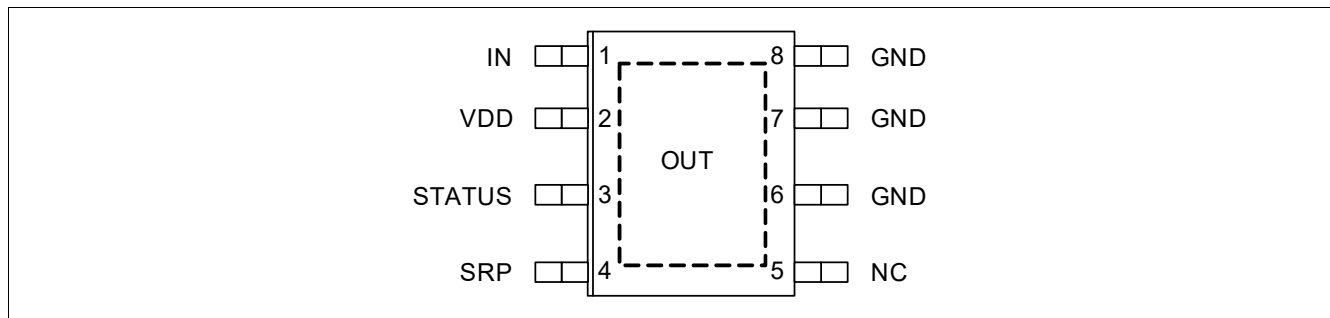

Figure 2 Pin Configuration. PG-TDSO-8

### 2.2 Pin Definitions and Functions

Pin	Symbol	I/O	Function
1	IN	I	If IN is high, switches ON the Power DMOS If IN is low, switches OFF the Power DMOS
2	VDD	I	Logic supply voltage pin, 3.3V to 5.5V
3	STATUS	I/O	RESET thermal latch function by microcontroller and pull-up If STATUS is high, device is in normal operation If STATUS is low, device is in over temperature condition
4	SRP	I	Slewrate control with external resistor
5	NC		Pin internally not connected
6, 7, 8	GND	I/O	GND; Source of power DMOS and logic <sup>1)</sup>
Cooling Tab	OUT	I/O	Load connection, Drain of power DMOS

1) All GND pins must be connected together

Pin Configuration

2.3 Voltage and Current Definition

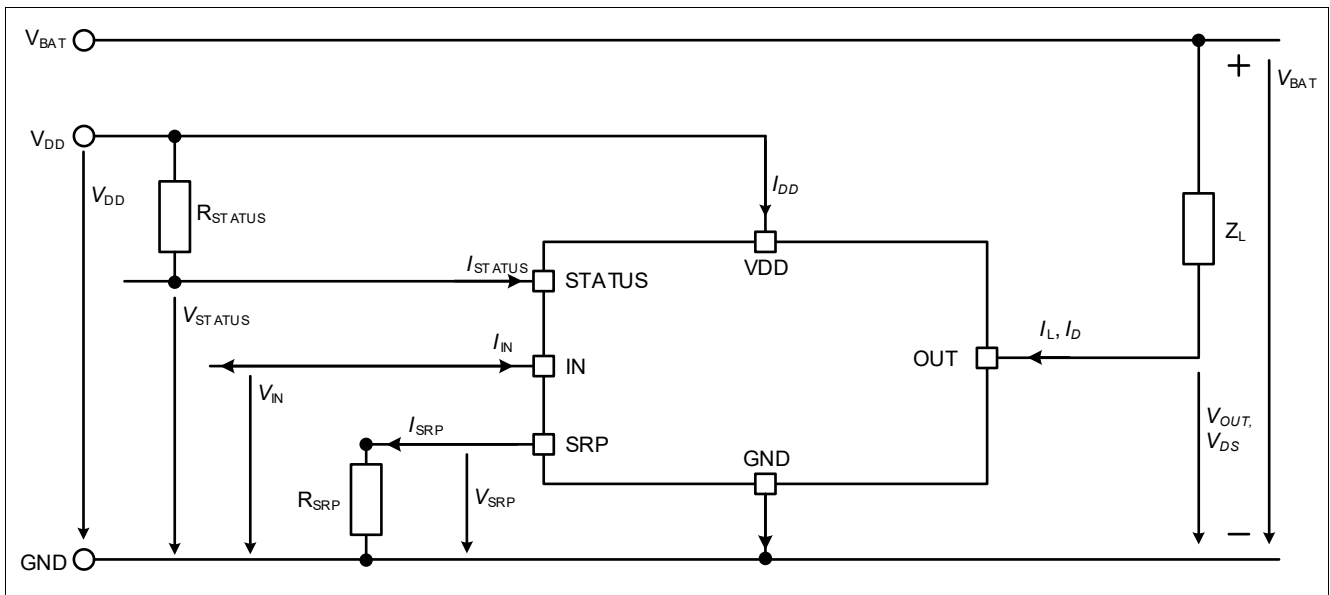

Figure 3 Naming definition of electrical parameters

General Product Characteristics

### 3 General Product Characteristics

#### 3.1 Absolute Maximum Ratings

**Table 2 Absolute Maximum Ratings<sup>1)</sup>**

$T_j = -40^\circ\text{C}$  to  $+150^\circ\text{C}$ ; all voltages with respect to ground, positive current flowing into pin (unless otherwise specified)

Parameter	Symbol	Values			Unit	Note or Test Condition	Number
		Min.	Typ.	Max.			
<b>Output Voltages</b>							
Output Voltage	$V_{\text{OUT}}$	-0.3	–	63	V	internally clamped	P_3.1.1
Battery Voltage for short circuit protection (Extended Range)	$V_{\text{BAT(SC)}}$	-0.3	–	36	V	$V_{\text{IN}} = 5\text{V}$	P_3.1.2
<b>Power Stage</b>							
Load current	$I_{\text{L}}$	0	–	$I_{\text{L(LIM)}}$	A	–	P_3.1.3
<b>Logic Pins</b>							
IN Pin Voltage	$V_{\text{IN}}$	-0.3	–	5.5	V	–	P_3.1.4
STATUS Pin Voltage	$V_{\text{STATUS}}$	-0.3	–	5.5	V	–	P_3.1.5
SRP Pin Voltage	$V_{\text{SRP}}$	-0.3	–	5.5	V	–	P_3.1.6
VDD Pin Voltage	$V_{\text{DD}}$	-0.3	–	6.5	V	–	P_3.1.7
<b>Energy capability</b>							
Energy. Single pulse	$E_{\text{AS}}$	–	–	150	mJ	$I_{\text{L(0)}} = I_{\text{L(NOM)}}$ $V_{\text{BAT}} = 28\text{V}$ $T_{\text{J(0)}} = 150^\circ\text{C}$	P_3.1.8
Energy. Repetitive pulse 1 M cycles	$E_{\text{AR(1M)}}$	–	–	80	mJ	$I_{\text{L(0)}} = I_{\text{L(NOM)}}$ $V_{\text{BAT}} = 28\text{V}$ $T_{\text{J(0)}} = 105^\circ\text{C}$	P_3.1.11
<b>Temperatures</b>							
Junction Temperature	$T_{\text{J}}$	-40	–	150	$^\circ\text{C}$	–	P_3.1.13
Storage Temperature	$T_{\text{STG}}$	-55	–	150	$^\circ\text{C}$	–	P_3.1.14
<b>ESD Susceptibility</b>							
ESD Susceptibility (all pins except OUT tab, to GND)	$V_{\text{ESD}}$	-2	–	2	kV	HBM <sup>2)</sup>	P_3.1.15
ESD Susceptibility (OUT tab to GND)	$V_{\text{ESD\_OUT}}$	-4	–	4	kV	HBM <sup>2)</sup>	P_3.1.16
ESD Susceptibility (all pins)	$V_{\text{ESD\_CDMA}}$	-500	–	500	V	CDM <sup>3)</sup>	P_3.1.17
ESD Susceptibility (corner pins)	$V_{\text{ESD\_CDMC}}$	-750	–	750	V	CDM <sup>3)</sup>	P_3.1.18

1) Not subject to production test, specified by design.

2) ESD susceptibility, HBM according to ANSI/ESDA/JEDEC JS001 (1.5 kΩ, 100 pF.)

3) ESD susceptibility, Charged Device Model “CDM” according JEDEC JESD22-C101.

**General Product Characteristics**

**Notes**

1. Stresses above the ones listed here may cause permanent damage to the device. Exposure to absolute maximum rating conditions for extended periods may affect device reliability.
2. Integrated protection functions are designed to prevent IC destruction under fault conditions described in the datasheet. Fault conditions are considered as outside normal operating range. Protection functions are not designed for continuous repetitive operation.

**3.2 Functional Range**

**Table 3 Functional Range**<sup>1)</sup>

Parameter	Symbol	Values			Unit	Note or Test Condition	Number
		Min.	Typ.	Max.			
Battery Voltage Range for Nominal Operation	$V_{BAT(NOR)}$	6	–	36	V	–	P_3.2.1
Supply Voltage Range for Nominal Operation	$V_{DD(NOR)}$	3.3	–	5.5	V	–	P_3.2.2
Supply Voltage Range for Extended_1 Operation	$V_{DD(EXT1)}$	3.0	–	5.5	V	<sup>1)</sup> Parameter deviations possible	P_3.2.6
Battery Voltage Range for Extended_2 Operation	$V_{DD(EXT2)}$	5.5	–	6.5	V	<sup>1)</sup> $V_{BAT} < 46V$ ; Parameter deviations possible	P_3.2.7
Junction Temperature	$T_J$	-40	–	150	°C	–	P_3.2.4
External Resistor Range for Adjustable Slewrate Operation	$R_{SRP}$	2.2	–	160	kΩ	–	P_3.2.5

<sup>1)</sup> Not subject to production test, specified by design.

**Note:** Within the functional or operating range, the IC operates as described in the circuit description. The electrical characteristics are specified within the conditions given in the Electrical Characteristics table.

General Product Characteristics

3.3 Thermal Resistance

Note: This thermal data was generated in accordance with JEDEC JESD51 standards. For more information, go to [www.jedec.org](http://www.jedec.org).

Table 4 Thermal Resistance

Parameter	Symbol	Values			Unit	Note or Test Condition	Number
		Min.	Typ.	Max.			
Junction to Case	$R_{thJC}$	–	0.84	–	K/W	1) 2)	P_3.3.1
Junction to Ambient 2s2p	$R_{thJA(2s2p)}$	–	30	–	K/W	1) 3)	P_3.3.2

- 1) Not subject to production test, specified by design.
- 2) Specified  $R_{thJC}$  value is simulated at natural convection on a cold plate setup. Bottom of the package is fixed to ambient temperature.  $T_{AMB} = 85^{\circ}C$ . Device loaded with 1 W power
- 3) Specified  $R_{thJA}$  value is according to Jedec JESD51-2,-7 at natural convection on FR4 2s2p board; The Product (Chip + Package) was simulated on a 76.2 × 114.3 × 1.5 mm board with 2 inner copper layers (2 × 70 μm Cu, 2 × 35 μm Cu).  $T_{AMB} = 85^{\circ}C$ . Device loaded with 1 W power

3.4 Transient Thermal Impedance

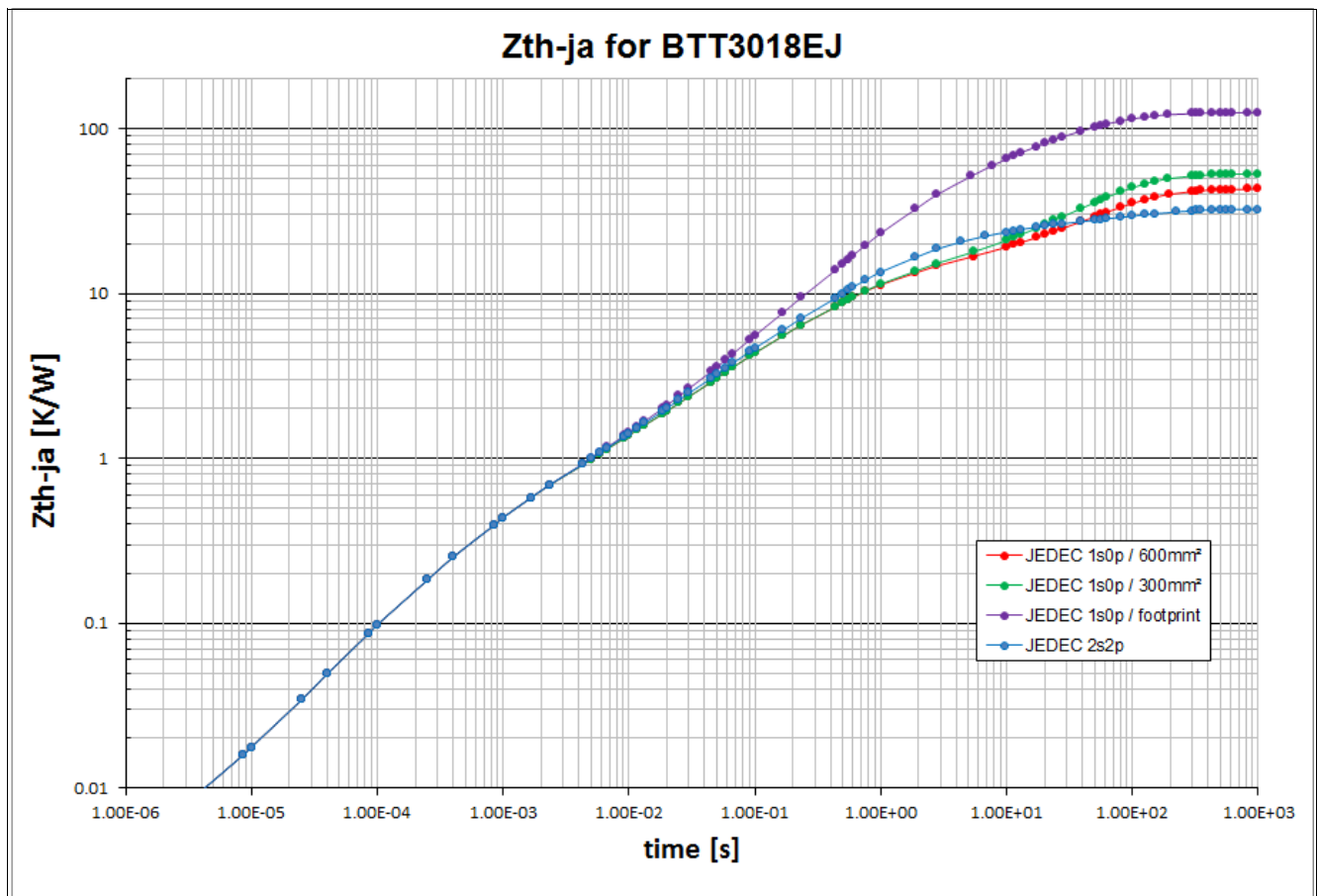
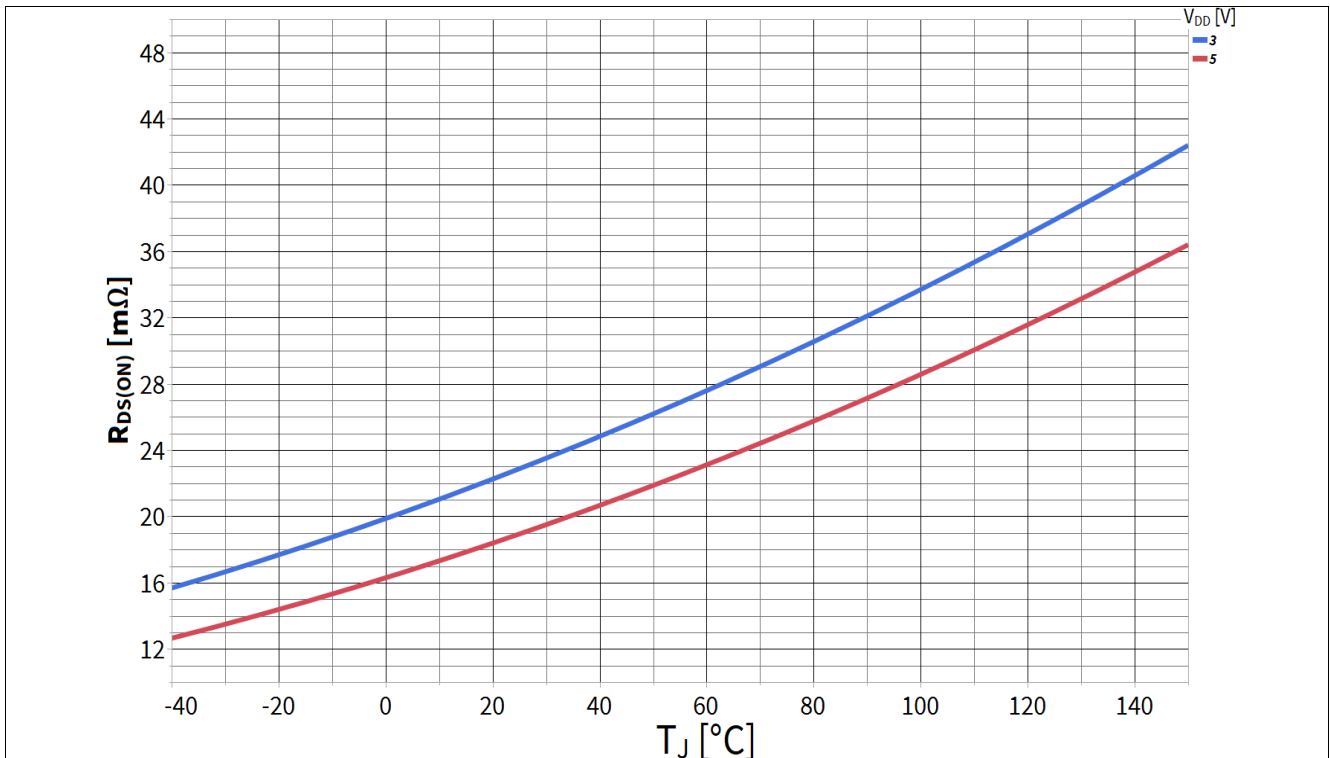

Figure 4 Typical transient thermal impedance  $Z_{thJA} = f(t_p)$ ,  $T_a = 85^{\circ}C$   
Value is according to Jedec JESD51-2, at natural convection on FR4 boards. Where applicable a thermal via array under the exposed pad contacted the first inner copper layer. Device is dissipating 1 W power.

## 4 Power Stage

### 4.1 Output On-state Resistance

The on-state resistance depends on the supply voltage ( $V_{DD}$ ) and on the junction temperature ( $T_J$ ). **Figure 5** shows these dependencies. The behavior in reverse polarity is described in chapter “**Reverse Current Capability**” on **Page 15**.



**Figure 5** Typical On-State Resistance,  
 $R_{DS(ON)} = f(T_J); V_{DD} = V_{IN} = 5V, 3V$

Power Stage

### 4.2 Resistive Load Output Timing

Figure 6 shows the typical timing when switching a resistive load.

Both  $-(\Delta V/\Delta t)_{ON}$  and  $(\Delta V/\Delta t)_{OFF}$  can be calculated using the following formulas:

Turn-on Slew rate:  $-(\Delta V/\Delta t)_{ON} = (0.6 \times V_{BAT}) / t_F$

Turn-off Slew rate:  $(\Delta V/\Delta t)_{OFF} = (0.6 \times V_{BAT}) / t_R$

NB: the coefficient 0.6 is based on 20% to 80% of  $V_{BAT}$ , this is how the measurement of  $\Delta V$  is defined.

As shown in Figure 6  $t_{ON}$  and  $t_{OFF}$  can be calculated from delay time ( $t_{DON}$ ,  $t_{DOFF}$ ) and falling/rising time ( $t_F$ ,  $t_R$ ) using the following formulas:

Turn-on time:  $t_{ON} = t_{DON} + t_F$

Turn-off time:  $t_{OFF} = t_{DOFF} + t_R$

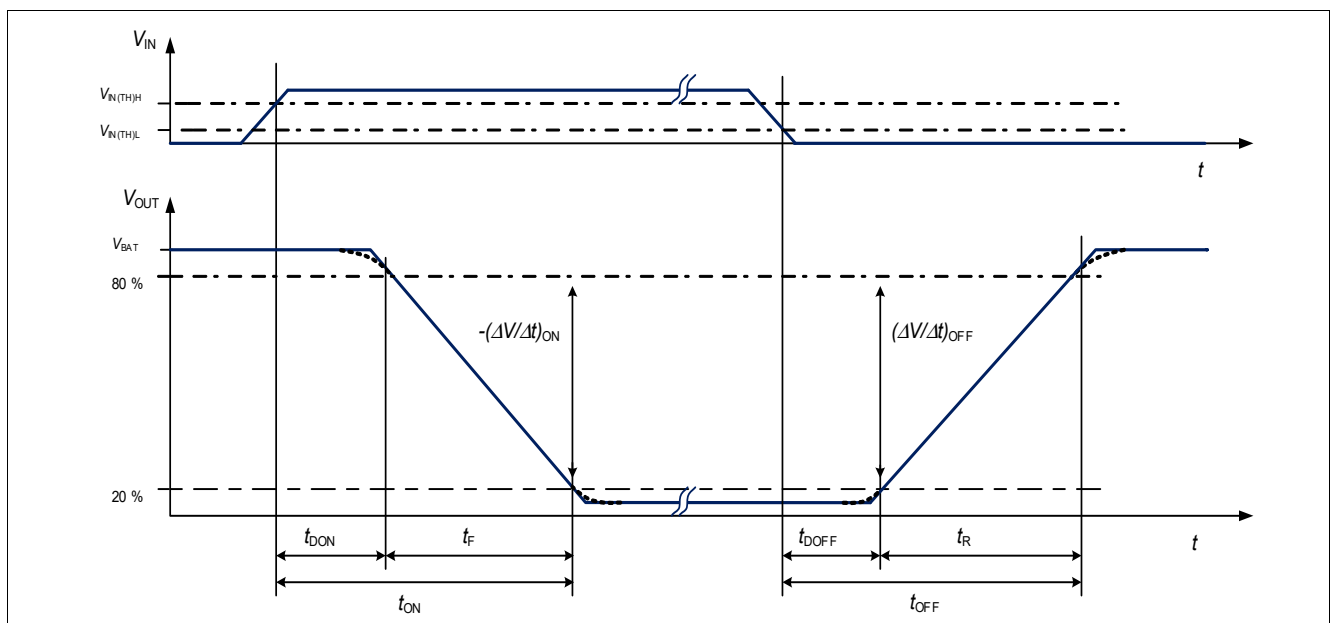

Figure 6 Definition of Power Output Timing for Resistive Load

### 4.3 Adjustable switching speed / Slew rate

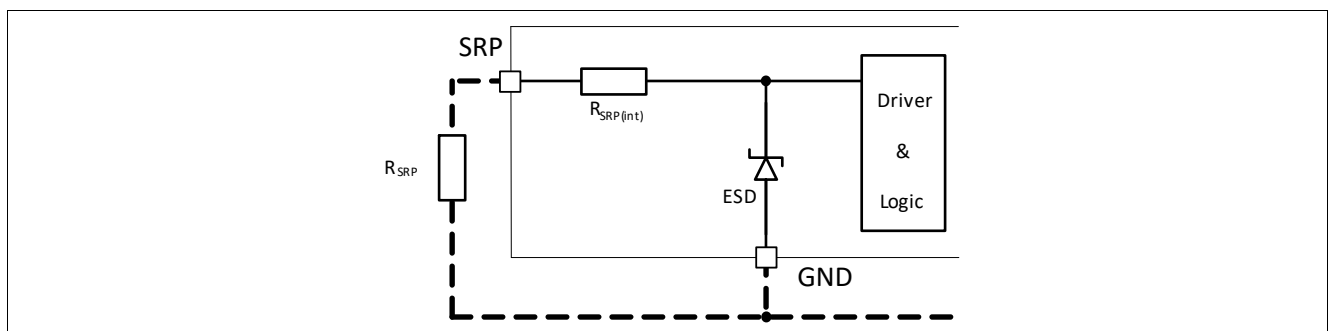

Figure 7 Simplified SRP circuit

Figure 7 shows the slew rate control circuit of the BTT3018EJ. The circuit includes an ESD protection mechanism via a zener structure.

Power Stage

In order to optimize the switching speed of the MOSFET to a specific application, an external resistor can be connected between SRP pin and GND to select the desired slew rate (see switching timings in [Chapter 8.1](#)). The adjustment of the slew rate also allows to balance between electromagnetic emissions and power dissipation.

To reduce the number of external components, the SRP pin can be connected directly to GND. This sets the slew rate at its largest value enabling fast switching timings.

It is not recommended to connect directly SRP pin to  $V_{DD}$  or to leave it floating (open).

The accuracy of the switching speed is dependent on the accuracy of the external resistor used. It is recommended to use short connections between the SRP pin and either  $R_{SRP}$ , GND bias.

Figure 8 show the typical relation between switching speed and the external SRP resistor ( $R_{SRP}$ ).

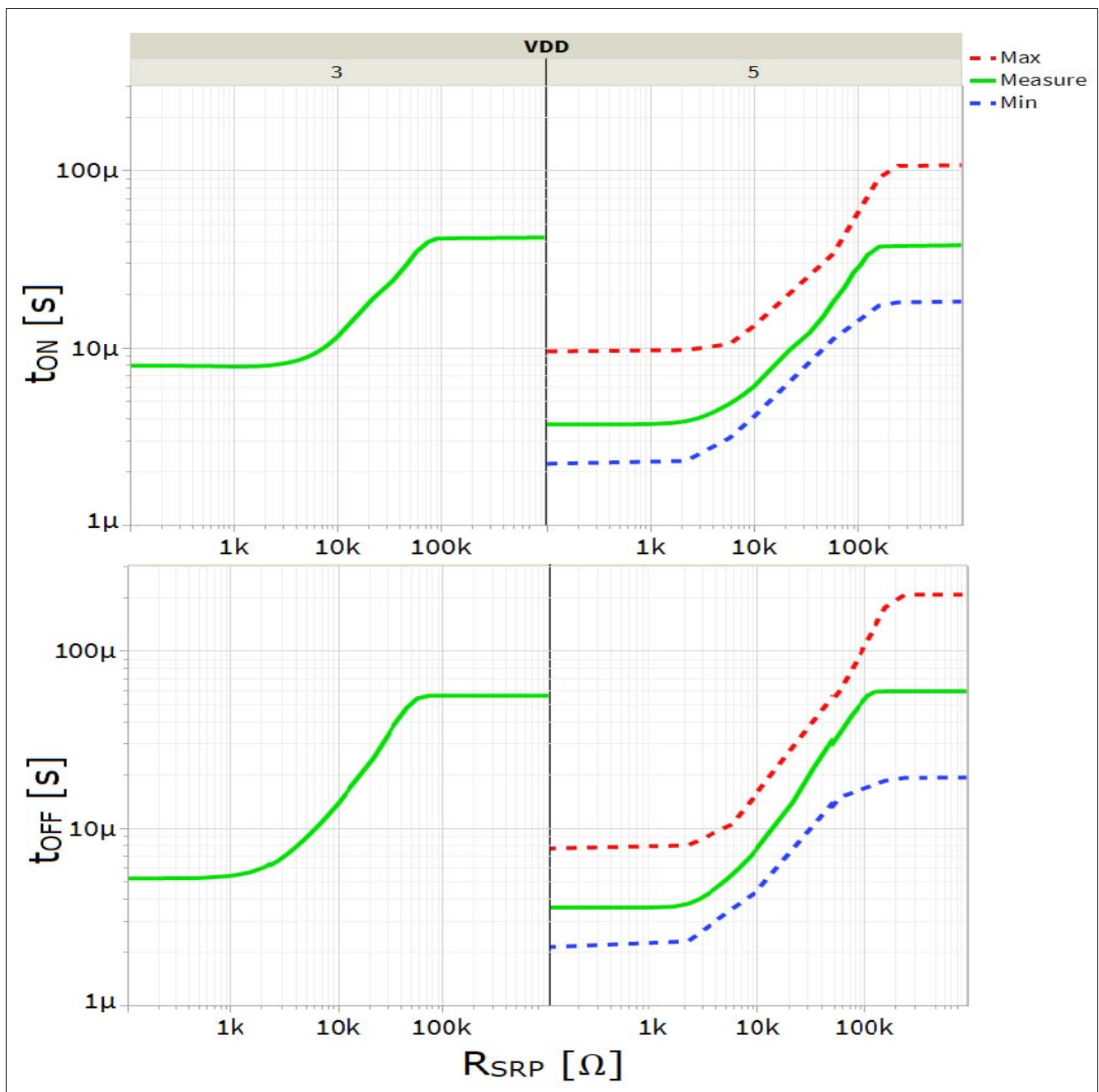

Figure 8 Typical diagram representing the relation between  $R_{SRP}$  and  $t_{ON}$ ,  $t_{OFF}$ ;  $V_{DD}$ = 3V, 5V

Power Stage

4.3.1 Output Clamping

When switching off inductive loads with low side switches, the drain-source voltage  $V_{OUT}$  rises above the battery potential due to the inductance tendency to continue driving the current. To prevent unwanted high voltages, the device has a voltage clamping mechanism to keep the voltage at  $V_{OUT(CLAMP)}$ . During this clamping operation mode the device heats up as it dissipates the energy from the inductance. Therefore the maximum allowed load inductance is limited. See [Figure 9](#) and [Figure 10](#) for more details.

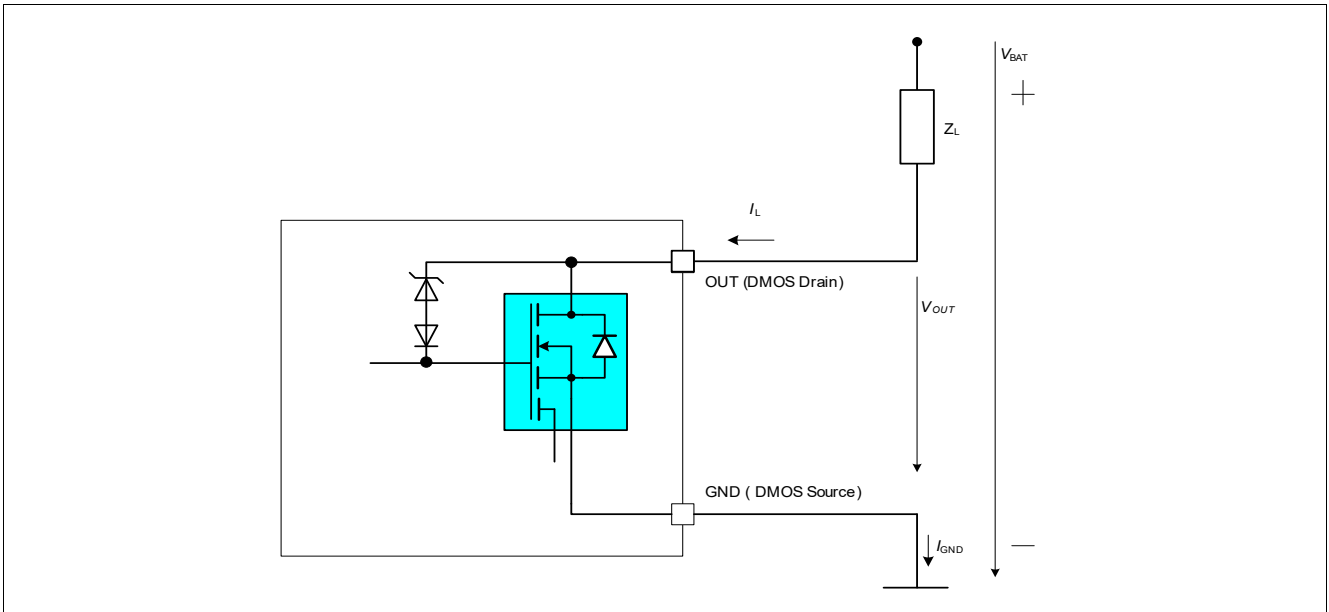

Figure 9 Output Clamp Circuitry

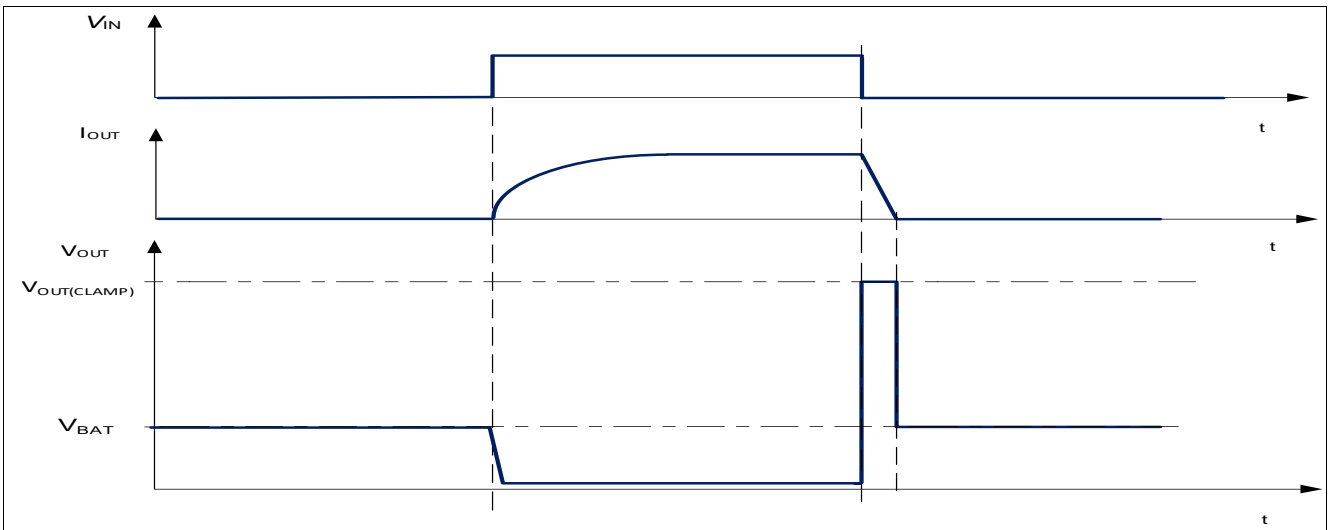

Figure 10 Switching an Inductive Load

Note: Repetitive switching of an inductive load by  $V_{DD}$  instead of using the input pin is a not recommended operation and may affect the device reliability and reduce the lifetime.

4.3.2 Maximum Load Inductance

During the demagnetization of inductive loads, energy has to be dissipated by the device. This energy can be calculated by the following equation:

**Power Stage**

$$E = V_{OUT(CLAMP)} \times \left[ \frac{V_{BAT} - V_{OUT(CLAMP)}}{R_L} \times \ln \left( 1 - \frac{R_L \times I_L}{V_{BAT} - V_{OUT(CLAMP)}} \right) + I_L \right] \times \frac{L}{R_L} \quad (4.1)$$

Following equation is simplified under the assumption of  $R_L = 0$

$$E = \frac{1}{2} L I_L^2 \times \left( 1 - \frac{V_{BAT}}{V_{BAT} - V_{OUT(CLAMP)}} \right) \quad (4.2)$$

**Figure 11** shows the inductance for a given current the device BTT3018EJ can withstand. For maximum single avalanche energy please also refer to  $E_{AS}$  parameter in **Chapter 3.1**

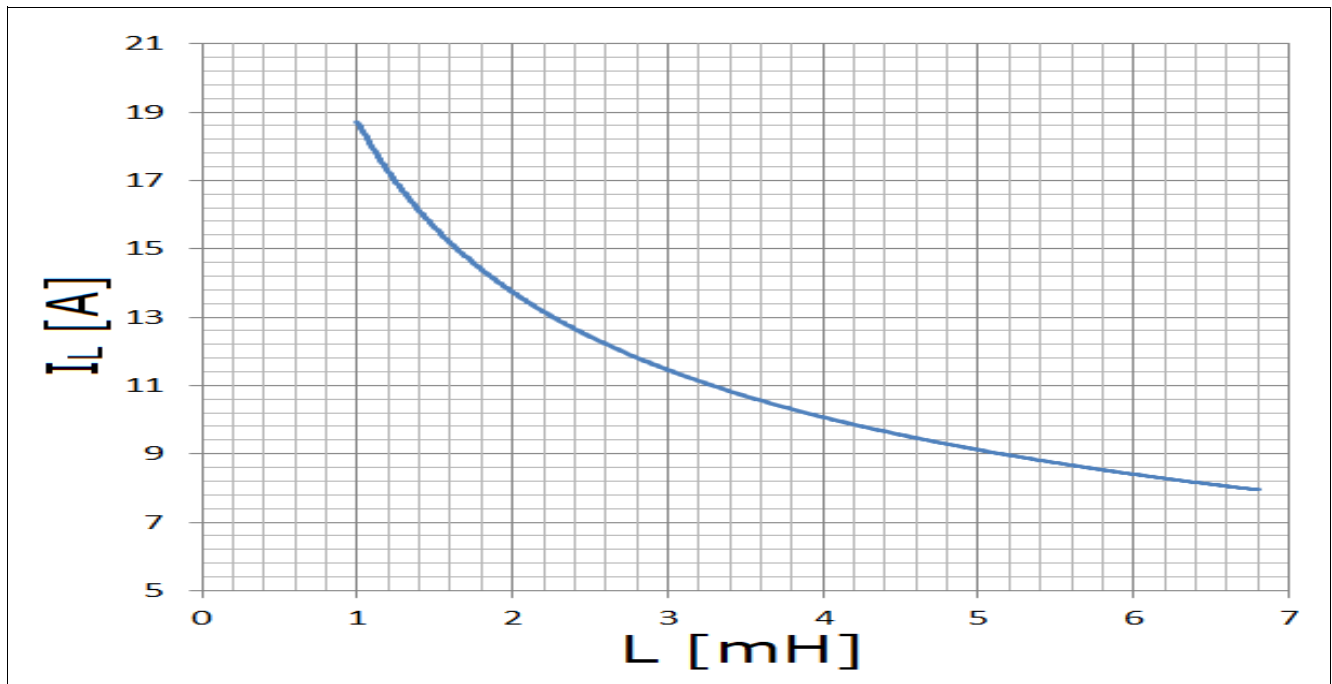

**Figure 11 Maximum load inductance for single pulse**  
 $I_L = f(L); T_{J(0)} = 150\text{ °C}; V_{BAT} = 28\text{ V}$

**4.4 Reverse Current Capability**

A reverse battery situation means that the device drain is pulled below GND potential to  $-V_{BAT}$ . In this situation the load is driven by a current through the intrinsic body diode of the BTT3018EJ and all protections, such as current limitation, over temperature or over voltage clamping, are not active.

In inverse or reverse operation via the reverse body diode, the device is dissipating a power loss which is defined by the driven current and the voltage drop on the body diode.

**4.5 Characteristics**

Please see **“Power Stage” on Page 23** for electrical characteristic table.

## 5 Supply and Input Stage

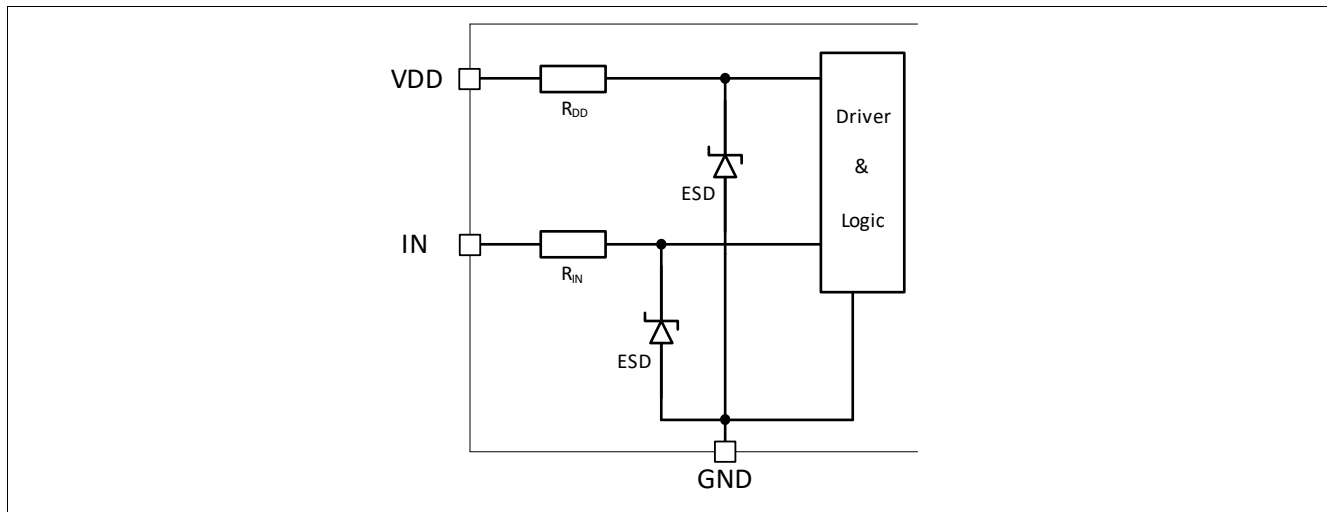

**Figure 12** Simplified supply and input circuit

**Figure 12** shows the supply and input circuit of the BTT3018EJ. Both terminals include an ESD protection mechanism via a zener structure.

### 5.1 Supply Circuit

The device's supply is not internally regulated but provided by an external supply. Therefore a reverse polarity protected and buffered (3.3V .. 5.5V) voltage supply is required at  $V_{DD}$  pin. To achieve the best  $R_{DS(ON)}$  and the fastest switching speed a 5V supply is required.

#### 5.1.1 Undervoltage Shutdown

In order to ensure a stable device behavior under all allowed conditions, the supply voltage  $V_{DD}$  is monitored. The output switches off if the supply voltage  $V_{DD}$  drops below the switch-off threshold  $V_{DD(TH)L}$ . If the supply voltage  $V_{DD}$  drops below the supply voltage reset threshold  $V_{DD(RESET)}$ , a reset of the STATUS signal and the latch-OFF state will occur. The device functions are only given for supply voltages above the supply voltage threshold  $V_{DD(TH)H}$ .

#### 5.1.2 Supply current consumption

The supply current consumption is determined by the state of the IN pin, being low, with the  $I_{DD(OFF)}$  and being high, with the  $I_{DD(ON)}$ . After a thermal shutdown, when the device is in OFF latch mode, the current consumption values matches the normal ON state  $I_{DD(ON)}$  as long as input is high.

However in PWM the consumption depends on the switching frequency. The higher the frequency, the higher the  $I_{DD(PWM)}$ .

**Figure 13** shows the typical relation between the supply current consumption and the switching frequency considering a duty-cycle of 50%.

Supply and Input Stage

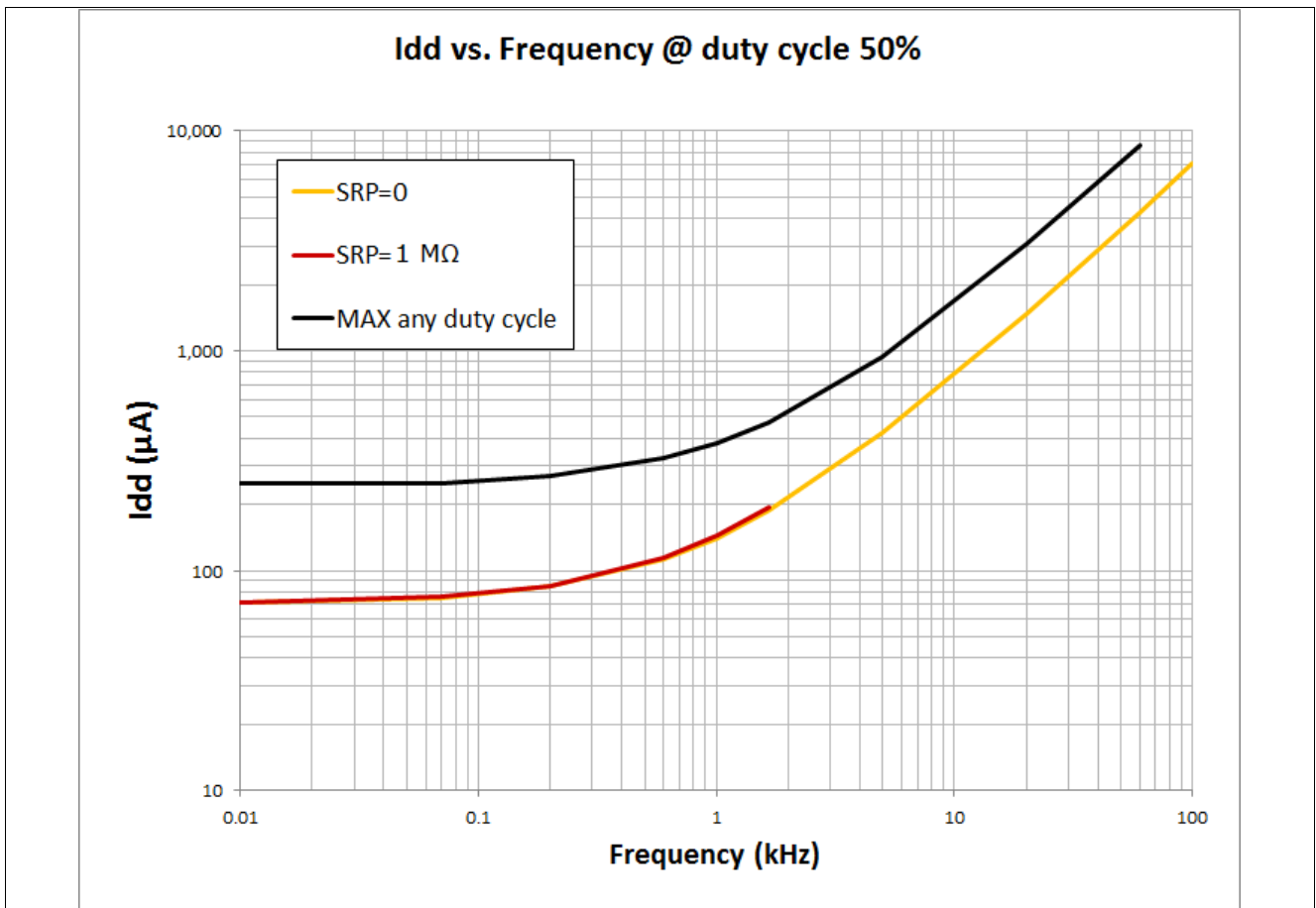

Figure 13 Typical  $I_{DD(PWM)}$  vs switching frequency at 50% duty-cycle

## 5.2 Characteristics

Please see “[Supply and Input Stage](#)” on [Page 26](#) for electrical characteristic table.

## 6 Protection Functions

The BTT3018EJ provides embedded protection functions. They are designed to prevent IC destruction under fault conditions described in the datasheet. Fault conditions are considered as “outside” normal operation. Protection functions are not to be used for continuous or repetitive operation.

### 6.1 Over Voltage Clamping on Output

The BTT3018EJ is designed with a voltage clamp circuitry that limits the drain-source voltage  $V_{DS}$  at a certain level  $V_{OUT(CLAMP)}$ . The over voltage clamping is overruling the other protection functions. Power dissipation has to be limited to not exceed the maximum allowed junction temperature.

This function is also used in terms of inductive clamping. Please see also **“Output Clamping” on Page 14** for more details.

### 6.2 Thermal Protection

The device is protected against over temperature due to overload and/or bad cooling conditions by an integrated static temperature sensor. The thermal protection is available when the device is active. In the event of over temperature shutdown  $T_{J(SD)}$ , the device will remain OFF until the device is reset via STATUS pin. Please see **Figure 14** and **Figure 15**.

### 6.3 Overcurrent Limitation / Short Circuit Behavior

This BTT3018EJ provides an overcurrent limitation intended to protect against short circuit or over current conditions.

When the drain current reaches the current limitation level  $I_{L(LIM)}$ , the device will limit the current at that level. While doing so, the power dissipation will heat up the device. Once the device reaches the over temperature shutdown threshold  $T_{J(SD)}$ , it will automatically shutdown and remain OFF until it is reset via STATUS pin.

### 6.4 Reset latch condition

The reset of the latch OFF mode is done in two steps that need to be performed in the correct sequence. During the first step, the voltage at the STATUS pin must be below the  $V_{STATUS(RESET)L}$  threshold for a time  $t > t_{STATUS(RESET)L}$ . In the second step of the reset sequence, the STATUS pin voltage needs to be pulled-up above the  $V_{STATUS(RESET)H}$  threshold for a time  $t > t_{STATUS(RESET)H}$ . The total reset time is given by the sum of  $t_{STATUS(RESET)L}$  and  $t_{STATUS(RESET)H}$ .

The following sub-chapters explain in more details the reset functionality in different conditions.

#### Reset via STATUS pin

If the temperature protection shutdowns the device, it will remain latched OFF independently of the input signal at IN pin. Simultaneously, the STATUS pin signal will be signalized low  $V_{STATUS(LATCH)}$ . In order to reset the latch condition, the STATUS pin needs to remain below  $V_{STATUS(RESET)L}$  for a minimum time  $t_{STATUS(RESET)L}$  before being externally pulled-up to  $V_{STATUS(RESET)H}$  for a minimum time  $t_{STATUS(RESET)H}$ . Please refer to **Figure 14** and the application diagram in **Figure 33**.

This configuration allows the device to be driven with high frequency PWM signal via the IN pin without a risk of resetting the device in case it goes in protection shut-down mode (latch OFF).

Protection Functions

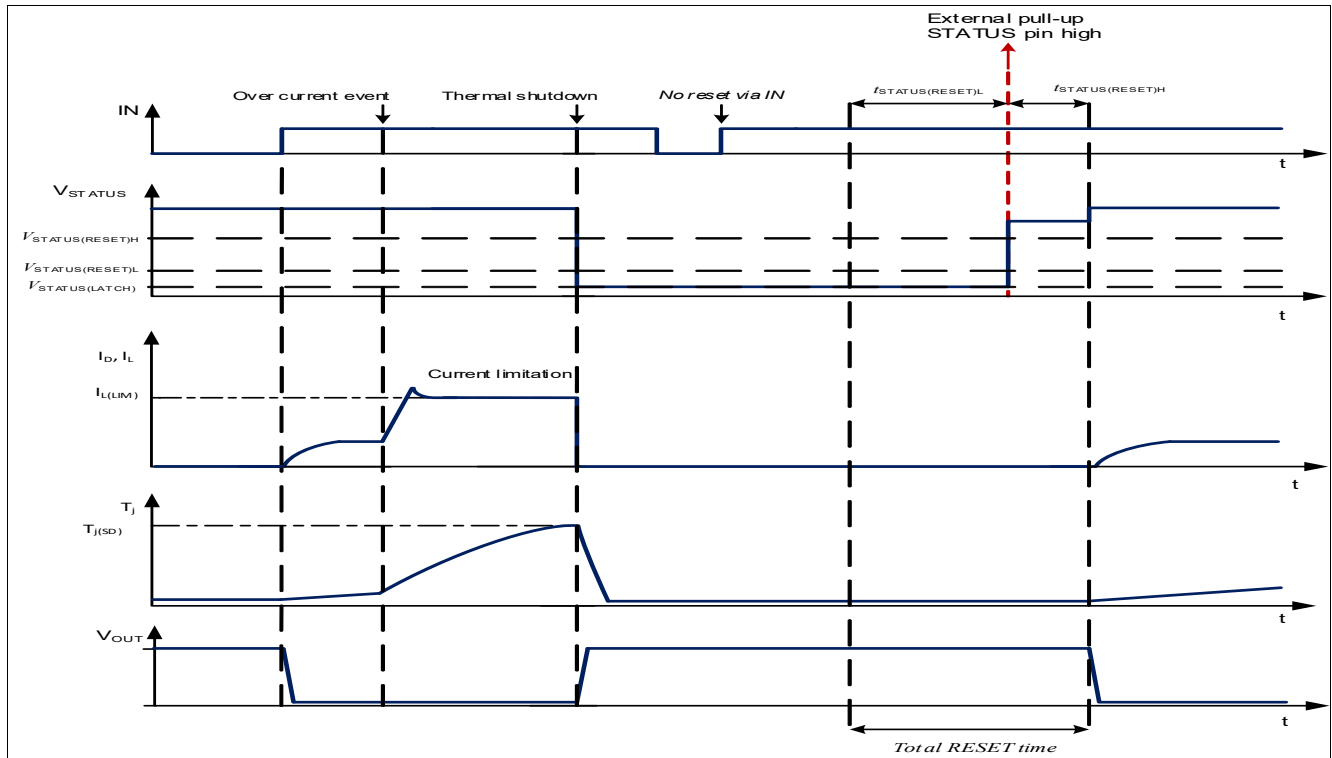

Figure 14 Mechanism to reset latch condition via STATUS pin

Reset via STATUS pin and IN pin connected together

If STATUS pin and IN pin are connected together (No  $R_{STATUS}$  pull-up external resistor), the voltage provided through the IN pin will prevent the STATUS low notification. To reset the device under this condition, the STATUS-IN connection needs to be pulled-down to  $V_{STATUS(RESET)L}$  for a minimum time  $t_{STATUS(RESET)L}$  before being pulled-up to  $V_{STATUS(RESET)H}$  for a minimum time  $t_{STATUS(RESET)H}$ . Please refer to [Figure 15](#) and the application diagram in [Figure 34](#).

If no diagnosis of the device is required, this configuration avoids the need of a dedicated I/O from the microcontroller for the STATUS pin. The maximum frequency to not reset the device allowed in PWM mode is constrained by the  $t_{STATUS(RESET)L}$  and  $t_{STATUS(RESET)H}$  times.

Protection Functions

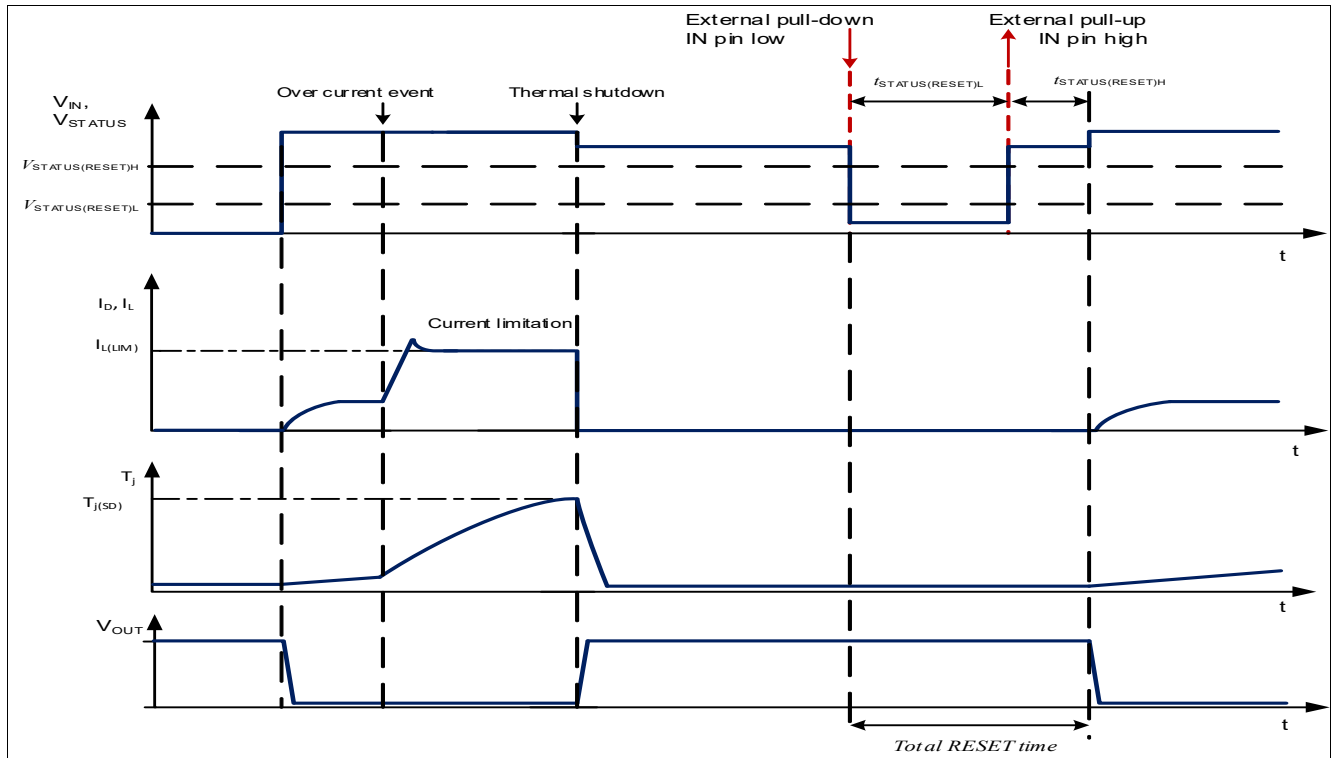

Figure 15 Mechanism to reset latch condition with STATUS pin and IN pin connected together

Note: For better understanding, the time scale is not linear. The real timing of this drawing is application dependant and cannot be described.

6.5 Characteristics

Please see “Protection” on Page 25 for electrical characteristic table.

## 7 Diagnostics

The BTT3018EJ provides a latching digital fault feedback signal on the STATUS pin triggered by an over temperature shutdown.

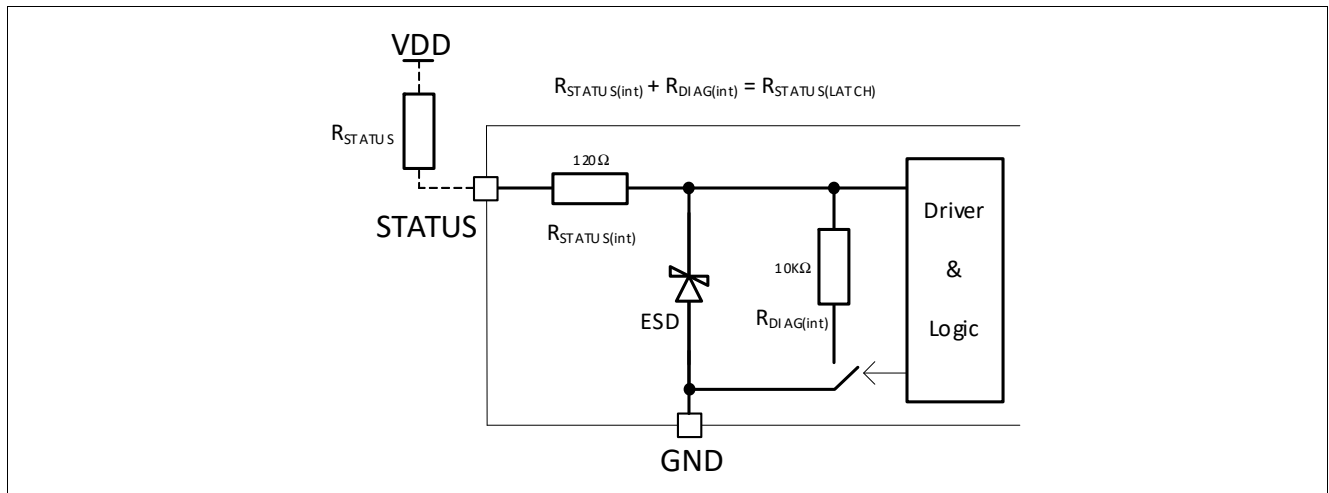

**Figure 16** Simplified diagnosis circuit

**Figure 16** shows the diagnosis circuit of the BTT3018EJ. The circuit include an ESD protection mechanism via a zener structure. Note that  $R_{STATUS(int)} + R_{DIAG(int)} = R_{STATUS(LATCH)}$  (cf. P\_8.5.12).

### 7.1 Functional Description of the STATUS Pin

The BTT3018EJ provides digital status information via the STATUS pin to give feedback to a connected microcontroller.

The readout of the diagnosis signal is only possible if the STATUS pin has a dedicated connection to the microcontroller and the appropriate pull-up resistor  $R_{STATUS}$  is in place. See **Figure 33** for recommended values of the external components.

The device is able to operate with STATUS pin and IN pin connected together, however this condition will inhibit the readout of the diagnosis signal.

#### Normal operation mode

In normal operation (no thermal shutdown) the STATUS pin's logic is set "high". It is pulled-up via an external Resistor ( $R_{STATUS}$ ) to  $V_{DD}$ . Internally it is connected to an open drain MOSFET through an internal resistor.

#### Fault operation mode

In case of a thermal shutdown (fault) the internal MOSFET connected to the STATUS pin, pulls it's voltage down to GND providing a "low" level signal to the microcontroller  $V_{STATUS(LATCH)}$ . Fault mode operation remains active independent from the input pin state until it is reset.

#### Reset latch fault signal (external pull up)

To reset the latch fault signal of the BTT3018EJ, the STATUS pin has to be externally pulled-up. This behavior is shown in **Figure 14 "Mechanism to reset latch condition via STATUS pin" on Page 19**.

For other configurations and how to reset the latch OFF of the DMOS, please see **"Reset latch condition" on Page 18**.

**Diagnostics**

**7.2 Characteristics**

Please see **“Diagnostics” on Page 28** for electrical characteristic table.

Electrical Characteristics

## 8 Electrical Characteristics

Note: Characteristics show the deviation of parameter at given input voltage and junction temperature. Typical values show the typical parameters expected from manufacturing and in typical application condition.  
All voltages and currents naming and polarity in accordance to [Figure 2.3 “Voltage and Current Definition” on Page 7.](#)

### 8.1 Power Stage

Please see Chapter [“Power Stage” on Page 11](#) for parameter description and further details.

**Table 5 Electrical Characteristics: Power Stage**

$T_j = -40^\circ\text{C}$  to  $+150^\circ\text{C}$ ,  $V_{\text{BAT}} = 28\text{ V}$ , all voltages with respect to ground, positive current flowing into pin (unless otherwise specified)

Parameter	Symbol	Values			Unit	Note or Test Condition	Number
		Min.	Typ.	Max.			
<b>Power Stage - Static Characteristics</b>							
On-State resistance at 5 V supply and 25°C	$R_{\text{DS(ON)}_5_{25}}$	–	16	20	mΩ	$V_{\text{DD}} = 5\text{ V};$ $T_j = 25^\circ\text{C}$	P_8.1.1
On-State resistance at 5 V supply and 150°C	$R_{\text{DS(ON)}_5_{150}}$	–	33	38	mΩ	$V_{\text{DD}} = 5\text{ V};$ $T_j = 150^\circ\text{C}$	P_8.1.2
On-State resistance at 3 V supply and 25°C	$R_{\text{DS(ON)}_3_{25}}$	–	20	30	mΩ	$V_{\text{DD}} = 3\text{ V};$ $T_j = 25^\circ\text{C}$	P_8.1.3
On-State resistance at 3 V supply and 150°C	$R_{\text{DS(ON)}_3_{150}}$	–	39	50	mΩ	$V_{\text{DD}} = 3\text{ V};$ $T_j = 150^\circ\text{C}$	P_8.1.4
Nominal load current	$I_{\text{L(NOM)}}$	–	7.0	–	A	<sup>1)</sup> $T_j < 150^\circ\text{C};$ $T_A = 85^\circ\text{C};$ $V_{\text{DD}} = 5\text{ V};$	P_8.1.5
OFF state load current, Output leakage current	$I_{\text{L(OFF)}_85}$	–	0	3.0	μA	<sup>2)</sup> $T_j \leq 85^\circ\text{C}$ $V_{\text{BAT(NOR)}}$	P_8.1.6
OFF state load current, Output leakage current at 150°C	$I_{\text{L(OFF)}_150}$	–	4	30	μA	$T_j = 150^\circ\text{C}$ $V_{\text{BAT(NOR)}}$	P_8.1.7
<b>Body Diode</b>							
Reverse diode forward voltage	$-V_{\text{DS}}$	–	0.6	1	V	$V_{\text{IN}} = 0\text{ V}$	P_8.1.8
<b>Switching times. <math>R_{\text{SRP}} = \text{short to GND}; V_{\text{BAT}} = 28\text{ V}; V_{\text{DD}} = 5\text{ V}; R_{\text{Load}} = 4.7\ \Omega</math> see <a href="#">Figure 6</a> for definition details</b>							
Turn-on delay time	$t_{\text{DON}_5(0)}$	1.6	2.7	6.8	μs	–	P_8.1.11
Turn-off delay time	$t_{\text{DOFF}_5(0)}$	1.5	2.8	5.5	μs	–	P_8.1.12
Turn-on output fall time	$t_{\text{F}_5(0)}$	0.5	1.4	2.5	μs	–	P_8.1.13

Electrical Characteristics

**Table 5 Electrical Characteristics: Power Stage** (cont'd)

$T_j = -40^\circ\text{C}$  to  $+150^\circ\text{C}$ ,  $V_{\text{BAT}} = 28\text{ V}$ , all voltages with respect to ground, positive current flowing into pin (unless otherwise specified)

Parameter	Symbol	Values			Unit	Note or Test Condition	Number
		Min.	Typ.	Max.			
Turn-off output rise time	$t_{\text{R}_5(0)}$	0.3	0.8	1.7	$\mu\text{s}$	-	P_8.1.14

**Switching times.  $R_{\text{SRP}} = 5.8\text{ k}\Omega$ ;  $V_{\text{BAT}} = 28\text{ V}$ ;  $V_{\text{DD}} = 5\text{ V}$ ;  $R_{\text{Load}} = 4.7\ \Omega$**   
see [Figure 6](#) for definition details

Turn-on delay time	$t_{\text{DON}_5(5\text{K8})}$	2.0	3.1	6.9	$\mu\text{s}$	-	P_8.1.33
Turn-off delay time	$t_{\text{DOFF}_5(5\text{K8})}$	2.4	4.5	7.6	$\mu\text{s}$	-	P_8.1.34
Turn-on output fall time	$t_{\text{F}_5(5\text{K8})}$	1.1	2.1	3.6	$\mu\text{s}$	-	P_8.1.35
Turn-off output rise time	$t_{\text{R}_5(5\text{K8})}$	1.0	1.7	2.9	$\mu\text{s}$	-	P_8.1.36

**Switching times.  $R_{\text{SRP}} = 58\text{ k}\Omega$ ;  $V_{\text{BAT}} = 28\text{ V}$ ;  $V_{\text{DD}} = 5\text{ V}$ ;  $R_{\text{Load}} = 4.7\ \Omega$**   
see [Figure 6](#) for definition details

Turn-on delay time	$t_{\text{DON}_5(58\text{K})}$	5.5	10.5	15.3	$\mu\text{s}$		P_8.1.55
Turn-off delay time	$t_{\text{DOFF}_5(58\text{K})}$	8	20.4	40.9	$\mu\text{s}$		P_8.1.56
Turn-on output fall time	$t_{\text{F}_5(58\text{K})}$	5.7	11.3	18.6	$\mu\text{s}$		P_8.1.57
Turn-off output rise time	$t_{\text{R}_5(58\text{K})}$	6.9	12.8	19.3	$\mu\text{s}$		P_8.1.58

**Switching times.  $R_{\text{SRP}} = 1\text{ M}\Omega$ ;  $V_{\text{BAT}} = 28\text{ V}$ ;  $V_{\text{DD}} = 5\text{ V}$ ;  $R_{\text{Load}} = 4.7\ \Omega$**   
see [Figure 6](#) for definition details

Turn-on delay time	$t_{\text{DON}_5(1\text{M})}$	9.3	17.0	42.2	$\mu\text{s}$	-	P_8.1.77
Turn-off delay time	$t_{\text{DOFF}_5(1\text{M})}$	10.4	44.2	139	$\mu\text{s}$	-	P_8.1.78
Turn-on output fall time	$t_{\text{F}_5(1\text{M})}$	8.9	26.7	64.7	$\mu\text{s}$	-	P_8.1.79
Turn-off output rise time	$t_{\text{R}_5(1\text{M})}$	8.9	27.1	68.2	$\mu\text{s}$	-	P_8.1.80

- 1) Not subject to production test, calculated by  $R_{\text{thJA}}$  and  $R_{\text{DS(ON)}}$ .
- 2) Not subject to production test, specified by design

**Electrical Characteristics**

**8.2 Protection**

Please see Chapter “**Protection Functions**” on Page 18 for parameter description and further details.

*Note: Integrated protection functions are designed to prevent IC destruction under fault conditions described in the datasheet. Fault conditions are considered as “outside” normal operating range. Protection functions are not designed for continuous repetitive operation*

**Table 6 Electrical characteristics: Protection**

$T_j = -40^\circ\text{C}$  to  $+150^\circ\text{C}$ ,  $V_{\text{BAT}} = 28\text{ V}$ ; all voltages with respect to ground, positive current flowing into pin (unless otherwise specified)

Parameter	Symbol	Values			Unit	Note or Test Condition	Number
		Min.	Typ.	Max.			
<b>Thermal shutdown</b>							
Static thermal shutdown junction temperature	$T_{\text{J(SD)}}$	150	175	200	$^\circ\text{C}$	<sup>1)</sup>	P_8.2.1
Overtemperature shutdown STATUS delay at 5 V	$t_{\text{TJ(SD)5}}$	–	4.5		$\mu\text{s}$	<sup>1)</sup> Delay time to trigger STATUS signal $V_{\text{DD}} = 5\text{ V}$ $T_{\text{AMB}} = 25^\circ\text{C}$	P_8.2.4
Overtemperature shutdown STATUS delay at 3 V	$t_{\text{TJ(SD)3}}$	–	4.2		$\mu\text{s}$	<sup>1)</sup> Delay time to trigger STATUS signal $V_{\text{DD}} = 3\text{ V}$ $T_{\text{AMB}} = 25^\circ\text{C}$	P_8.2.7
<b>Overvoltage Protection / Clamping</b>							
Drain clamp voltage	$V_{\text{OUT(CLAMP)}}$	63	72	83	V	$I_{\text{D}} > 50\text{ mA}$	P_8.2.8
<b>Current limitation</b>							
Current limitation level	$I_{\text{L(LIM)_5}}$	30	45	60	A	<sup>2)</sup> $V_{\text{DD}} = 5\text{ V};$	P_8.2.9

1) Not subject to production test, specified by design.

2) Parameter tested at  $V_{\text{BAT}} = 5\text{ V}$ ; specified up to  $V_{\text{BAT}} = 36\text{ V}$ .

**Electrical Characteristics**

**8.3 Supply and Input Stage**

Please see Chapter “[Supply and Input Stage](#)” on [Page 16](#) for description and further details.

**Table 7 Electrical Characteristics: Supply and Input**

$T_j = -40^\circ\text{C}$  to  $+150^\circ\text{C}$ ,  $V_{\text{BAT}} = 28\text{ V}$ , all voltages with respect to ground, positive current flowing into pin (unless otherwise specified)

Parameter	Symbol	Values			Unit	Note or Test Condition	Number
		Min.	Typ.	Max.			
<b>Supply</b>							
Supply on threshold voltage high	$V_{\text{DD(TH)H}}$	2.4	2.8	3.0	V		P_8.3.2
Supply off threshold voltage low	$V_{\text{DD(TH)L}}$	2.3	2.7	2.9	V	<sup>1)</sup> DMOS switches OFF below threshold	P_8.3.3
Supply current, continuous ON operation	$I_{\text{DD(ON)}}$	–	150	250	μA	ON-state ; $V_{\text{IN}} = 5\text{V}$ ; $I_{\text{L(0)}} = I_{\text{L(NOM)}}$	P_8.3.5
Standby supply current	$I_{\text{DD(OFF)}}$	–	0.3	3	μA	$V_{\text{IN}} = 0\text{ V}$ $V_{\text{DD}} = 5.0\text{ V}$	P_8.3.11

**Electrical Characteristics**

**Table 7 Electrical Characteristics: Supply and Input (cont'd)**

$T_j = -40^{\circ}\text{C}$  to  $+150^{\circ}\text{C}$ ,  $V_{\text{BAT}} = 28\text{ V}$ , all voltages with respect to ground, positive current flowing into pin (unless otherwise specified)

Parameter	Symbol	Values			Unit	Note or Test Condition	Number
		Min.	Typ.	Max.			
<b>Input</b>							
Input on threshold voltage; 5.5 V supply	$V_{\text{IN(TH)H}_5.5}$	1.9	2.4	2.8	V	$V_{\text{DD}} = 5.5\text{ V}$	P_8.3.13
Input off threshold voltage; 5.5 V supply	$V_{\text{IN(TH)L}_5.5}$	1.2	1.5	1.8	V	$V_{\text{DD}} = 5.5\text{ V}$	P_8.3.14
Input on threshold voltage; 3 V supply	$V_{\text{IN(TH)H}_3}$	1.2	1.5	1.8	V	$V_{\text{DD}} = 3.0\text{ V}$	P_8.3.19
Input off threshold voltage; 3 V supply	$V_{\text{IN(TH)L}_3}$	0.7	1.0	1.2	V	$V_{\text{DD}} = 3.0\text{ V}$	P_8.3.20
Input pull down current	$I_{\text{IN}}$	20	45	80	$\mu\text{A}$	$V_{\text{IN}} \leq 5.5\text{ V};$ $V_{\text{DD}} \leq 5.5\text{ V}$	P_8.3.22

1) Undervoltage shutdown protection doesn't reset the OFF Latch mode.

## Electrical Characteristics

### 8.4 Diagnostics

Please see Chapter “[Diagnostics](#)” on [Page 21](#) for description and further details.

**Table 8 Electrical Characteristics: Diagnostics**

$T_j = -40^\circ\text{C}$  to  $+150^\circ\text{C}$ ,  $V_{\text{BAT}} = 28\text{ V}$ , all voltages with respect to ground, positive current flowing into pin (unless otherwise specified)

Parameter	Symbol	Values			Unit	Note or Test Condition	Number
		Min	Typ	Max			
<b>Diagnostics</b>							
Status pin latch voltage	$V_{\text{STATUS(LATCH)}}$	–	–	1.0	V	<sup>1) 2)</sup> $V_{\text{DD}} = 5\text{ V}$ ; $R_{\text{STATUS}} = 100\text{ k}\Omega$ ; $3\text{ V} \leq V_{\text{IN}} \leq 5\text{ V}$ ; latched fault signal	P_8.5.1
Status pin reset threshold low	$V_{\text{STATUS(RESET)L}_5}$	1.0	1.4	1.7	V	<sup>3)</sup> $V_{\text{DD}} = 5\text{ V}$	P_8.5.2
Status pin reset threshold high	$V_{\text{STATUS(RESET)H}_5}$	1.7	2.2	2.6	V	<sup>4)</sup> $V_{\text{DD}} = 5\text{ V}$	P_8.5.3
Status reset low time	$t_{\text{STATUS(RESET)L}_5}$	1.0	1.6	2.4	ms	<sup>1)5)</sup> $V_{\text{DD}} = 5\text{ V}$	P_8.5.4
Status reset high time	$t_{\text{STATUS(RESET)H}_5}$	20	35	50	$\mu\text{s}$	<sup>1)6)</sup> $V_{\text{DD}} = 5\text{ V}$	P_8.5.5
Status pin reset threshold low	$V_{\text{STATUS(RESET)L}_3}$	0.7	1.0	1.2	V	<sup>3)</sup> $V_{\text{DD}} = 3\text{ V}$	P_8.5.6
Status pin reset threshold high	$V_{\text{STATUS(RESET)H}_3}$	1.2	1.6	1.9	V	<sup>4)</sup> $V_{\text{DD}} = 3\text{ V}$	P_8.5.7
Status reset low time	$t_{\text{STATUS(RESET)L}_3}$	0.5	1.0	2.3	ms	<sup>1)5)</sup> $V_{\text{DD}} = 3\text{ V}$	P_8.5.8
Status reset high time	$t_{\text{STATUS(RESET)H}_3}$	8	15	50	$\mu\text{s}$	<sup>1)6)</sup> $V_{\text{DD}} = 3\text{ V}$	P_8.5.9
Status pin leakage current; (No Latch)	$I_{\text{STATUS(NOLATCH)}}$	–	–	1	$\mu\text{A}$	<sup>1)</sup> $3\text{ V} \leq V_{\text{DD}} \leq 5.5\text{ V}$ $V_{\text{STATUS}} \leq 5.5\text{ V}$ ; $0\text{ V} \leq V_{\text{IN}} \leq 5.5\text{ V}$	P_8.5.10
Status pin internal resistance, (Latch active)	$R_{\text{STATUS(LATCH)}}$	7	10	15	K $\Omega$	$R_{\text{STATUS(LATCH)}} = R_{\text{STATUS(int)}} + R_{\text{DIAG(int)}}$	P_8.5.12

1) Not subject to production test. Specified by design.

2) Latch feedback signal voltage drop considering  $V_{\text{DD}} = 5\text{ V}$  and  $R_{\text{STATUS}} = 100\text{ k}\Omega$ .

3) Voltage threshold needed at the STATUS pin to initialize the reset sequence of the latch OFF mode. If STATUS pin and IN pin are connected together, same voltage threshold applies.

4) Voltage threshold needed at the STATUS pin to complete the reset sequence of the latch OFF mode. If STATUS pin and IN pin are connected together, same voltage range applies.

5) Time needed to remain below  $V_{\text{STATUS(RESET)L}}$  to initialize the reset sequence of the latch OFF mode. See [Chapter 6.4](#) for more information

---

**Electrical Characteristics**

- 6) Time needed to remain above  $V_{\text{STATUS(RESET)H}}$  after  $V_{\text{STATUS(RESET)L}}$  is applied to conclude the reset sequence. See [Chapter 6.4](#) for more information

Characterisation Results

## 9 Characterisation Results

Typical performance characteristics

### 9.1 Power Stage

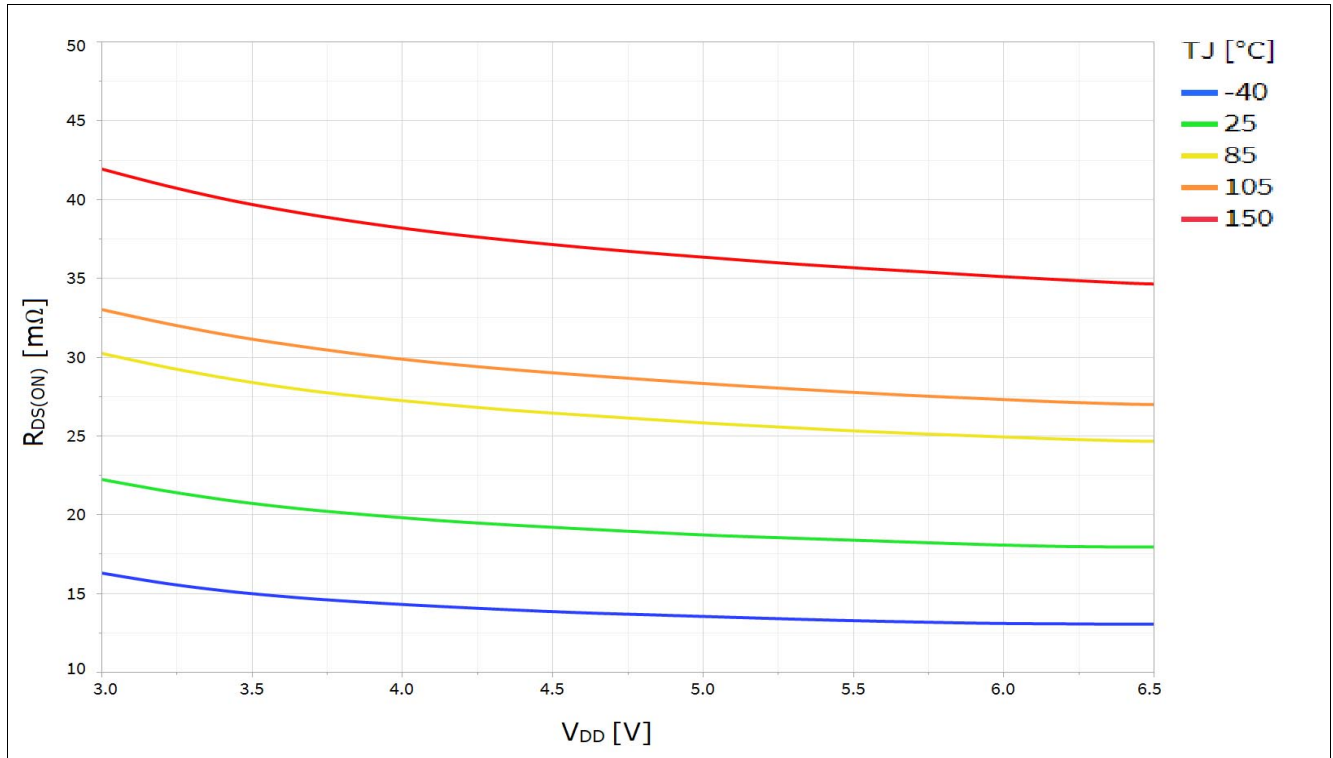

Figure 17 Typical  $R_{DS(ON)}$  vs.  $V_{DD}$ ;  $I_L = I_{L(NOM)}$ ;  $V_{IN} = 3V$ ;  $V_{BAT} = 28V$ ;  $R_{SRP} = 0\Omega$

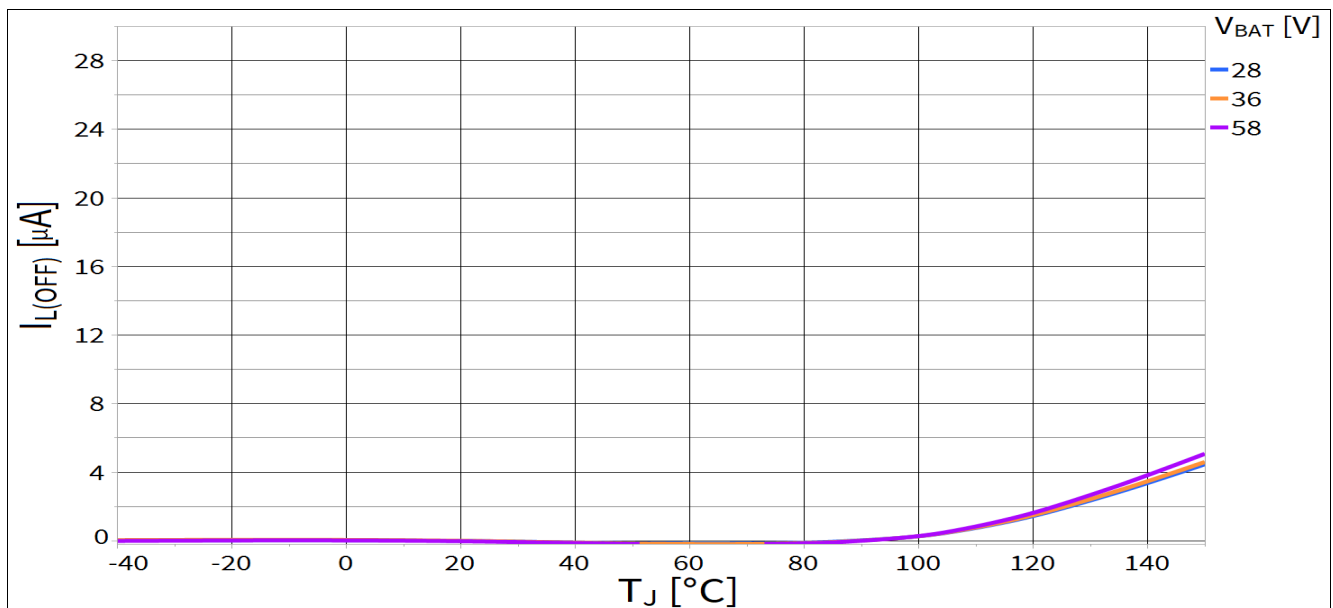

Figure 18 Typical  $I_{L(OFF)}$  vs.  $T_J$  @  $V_{IN} = 0V$ ;  $V_{DD} = 0, 5V$

Characterisation Results

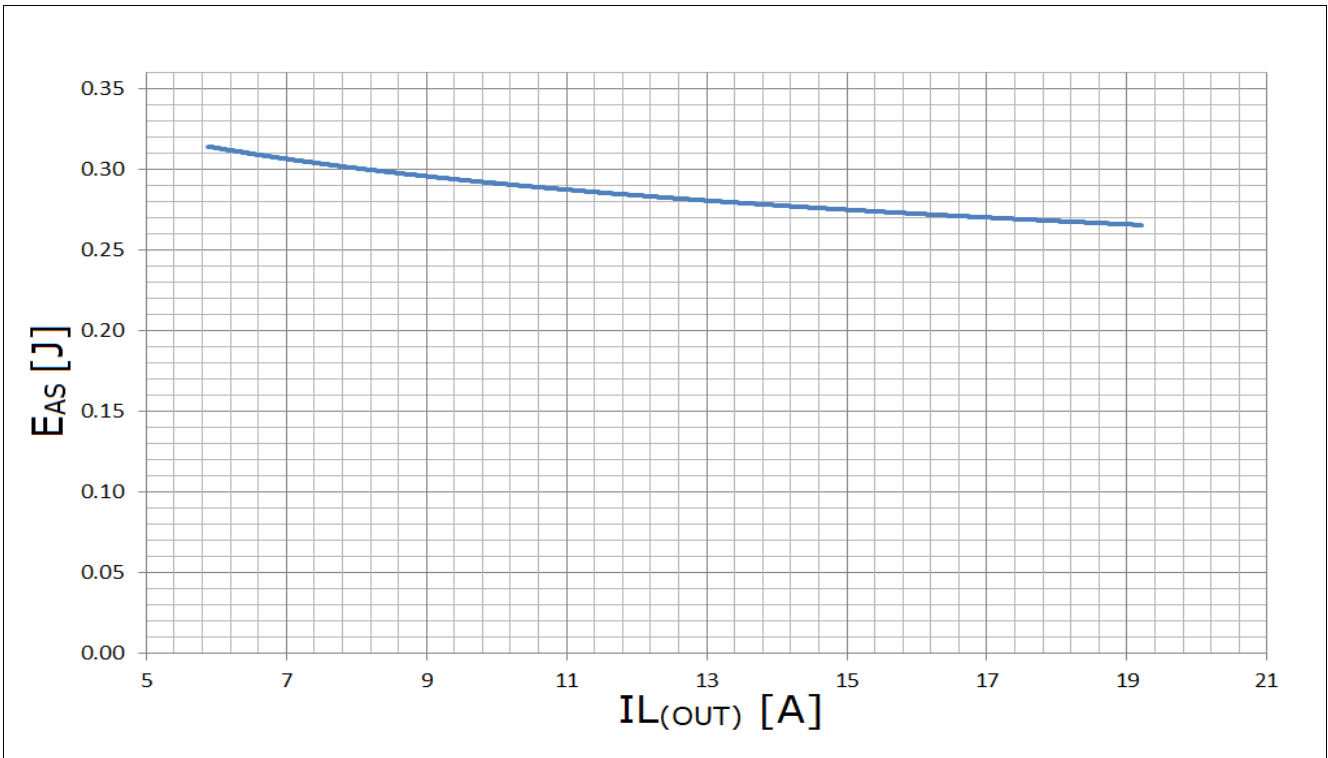

Figure 19 Typical destruction point  $E_{AS}$  vs.  $I_L$  @  $T_{J(0)}=150^\circ\text{C}$ ;  $V_{BAT}=28\text{V}$ ;  $I_L = I_{L(NOM)}, 2 * I_{L(NOM)}$

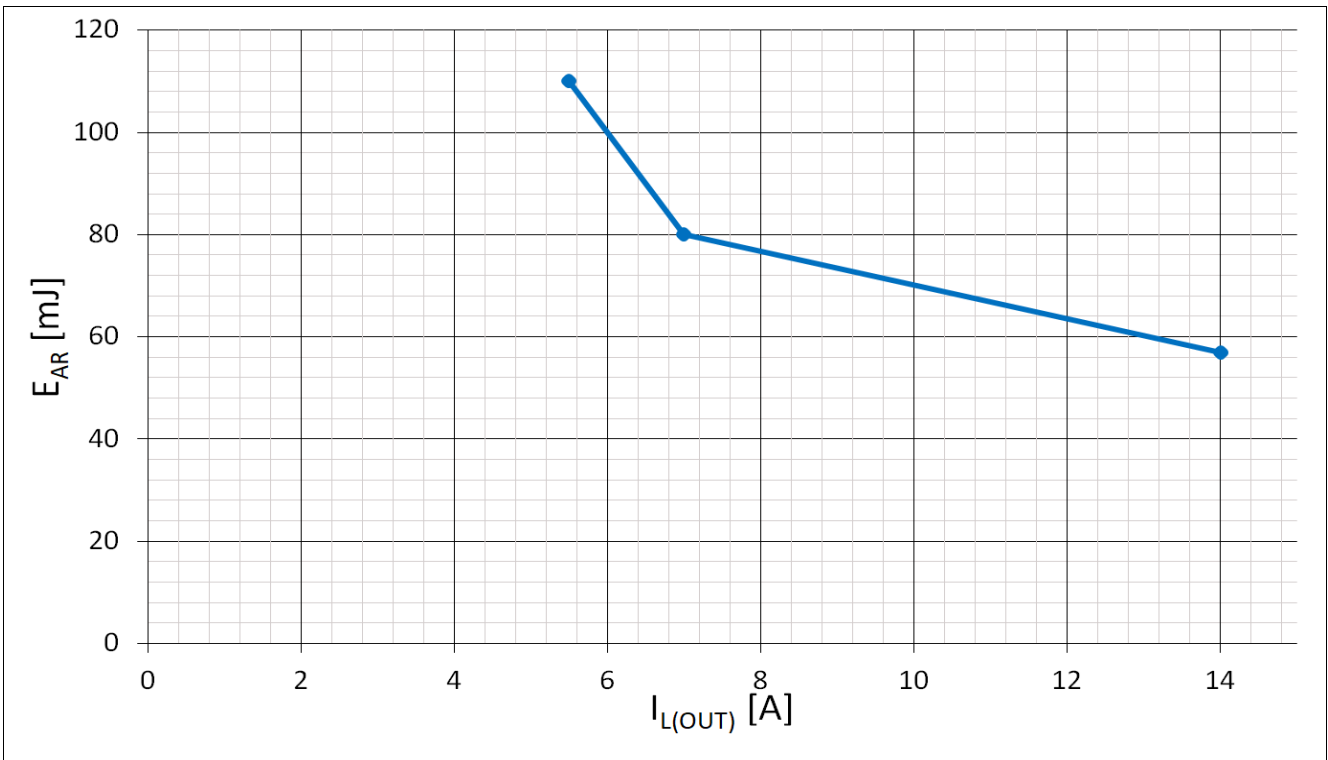

Figure 20 Typical  $E_{AR}$  vs.  $I_L$  @  $T_{J(0)}=105^\circ\text{C}$ ,  $V_{BAT}=28\text{V}$ ; Nr cycles = 10k, 100k, 1Mio cycles;  $I_L = I_{L(NOM)}, 2 * I_{L(NOM)}$

Characterisation Results

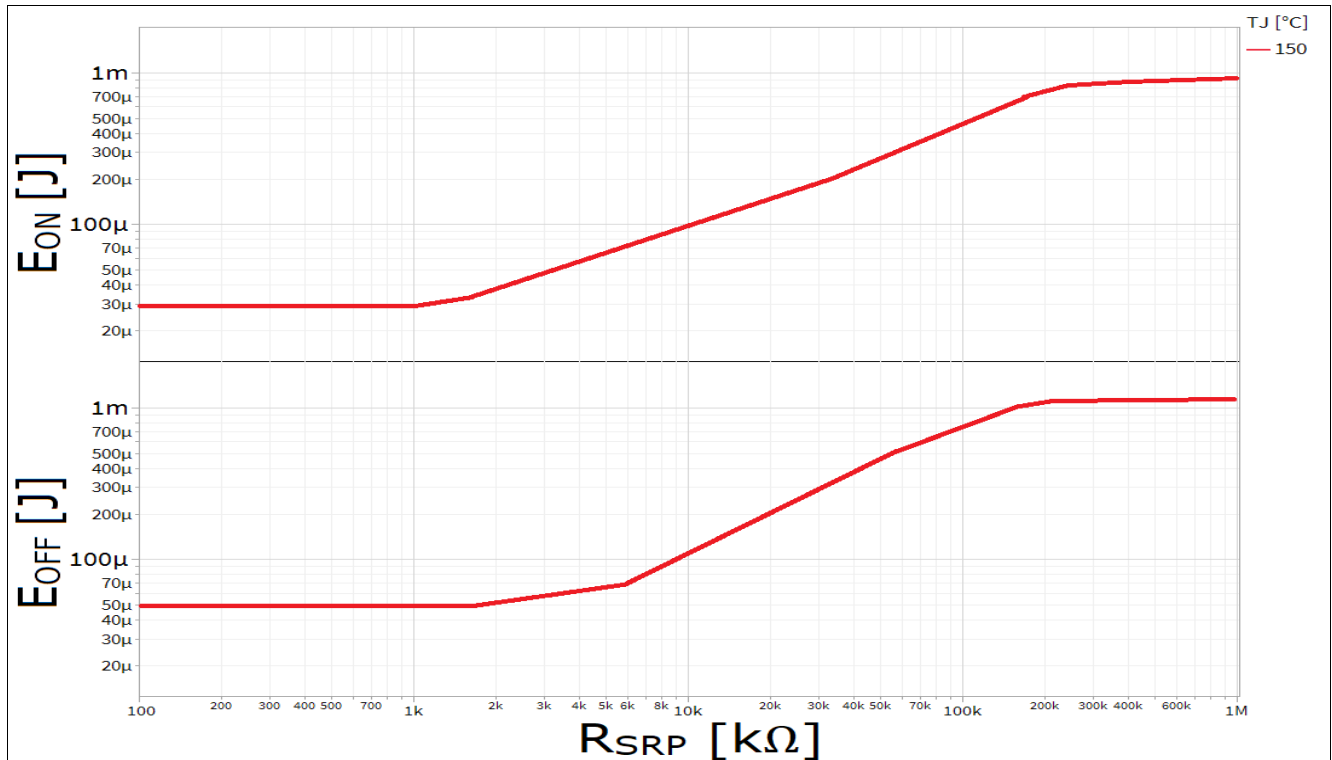

Figure 21 Typical EON & EOFF vs. SRP @  $T_{J(0)}=150^{\circ}\text{C}$ ,  $V_{DD}=5.5\text{V}$  &  $V_{DD}=3\text{V}$ ;  $V_{BAT} = 28\text{V}$ ;  $I_N = 5\text{V}$ ; STATUS= pulled-up to  $V_{DD}$ ;  $I_L = I_{L(NOM)}$

Dynamic characteristics

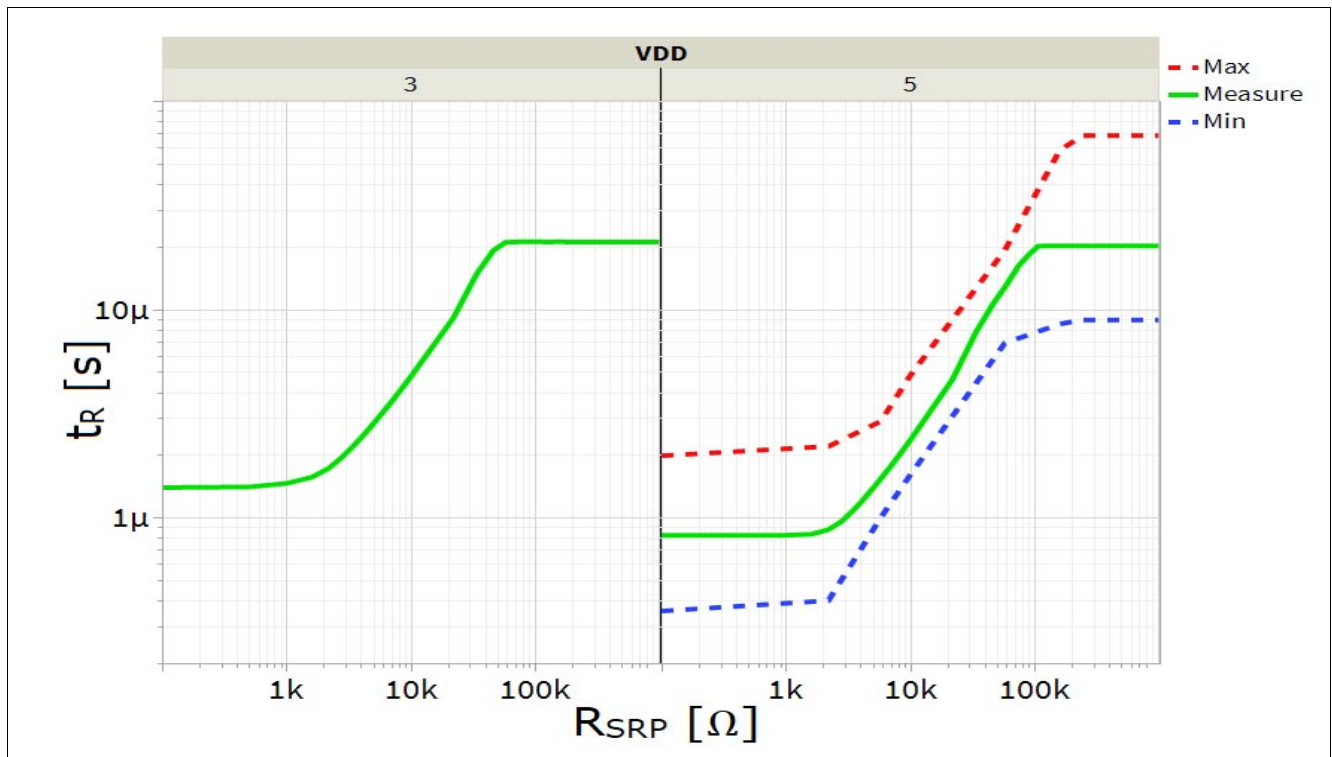

Figure 22 Typical  $t_R$  vs.  $R_{SRP}$  @  $V_{IN} = 5\text{V}$ ;  $V_{DD} = 3\text{V}, 5\text{V}$ ;  $V_{BAT} = 28\text{V}$ ;  $R_L = 4.7\Omega$ ;  $T_J = [-40 .. 150^{\circ}\text{C}]$

Characterisation Results

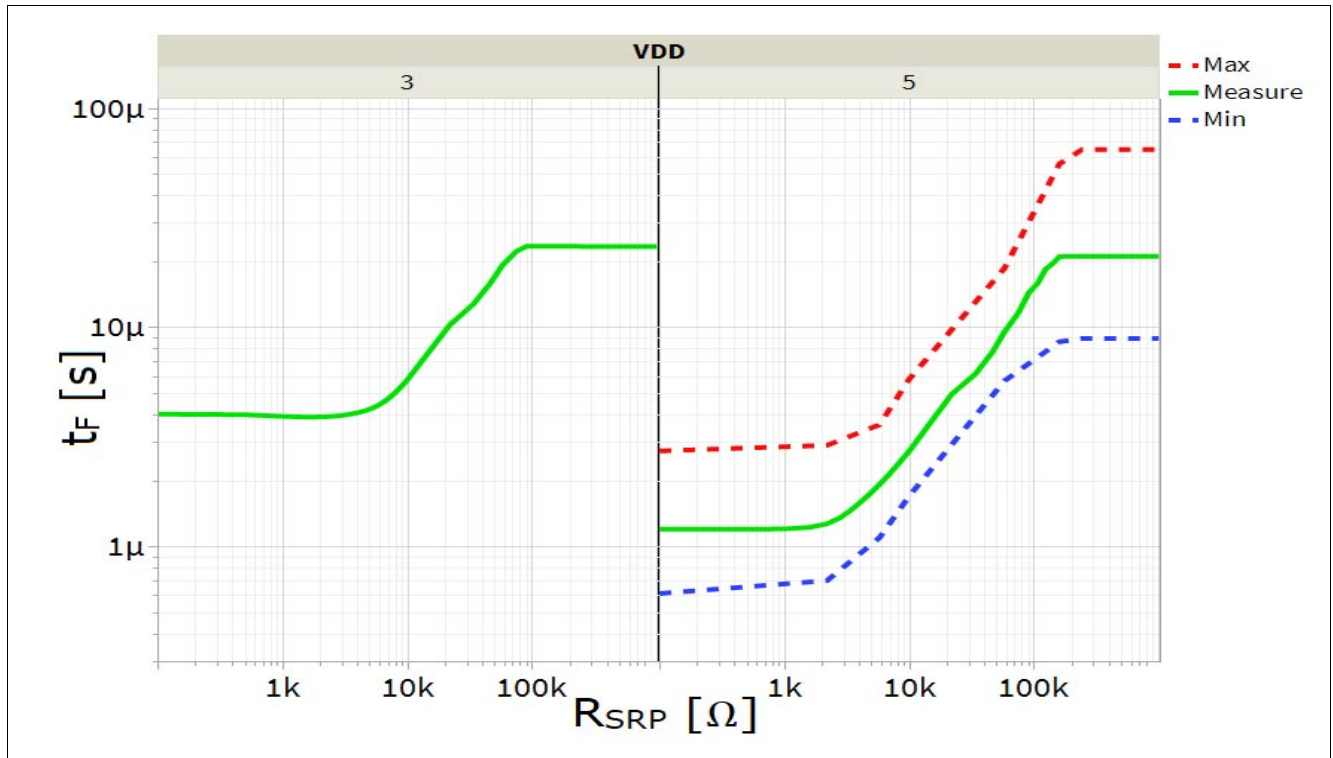

Figure 23 Typical  $t_F$  vs.  $R_{SRP}$  @  $V_{IN} = 5V$ ;  $V_{DD} = 3V, 5V$ ;  $V_{BAT} = 28V$ ;  $R_L = 4.7\Omega$ ;  $T_J = [-40 .. 150^\circ C]$

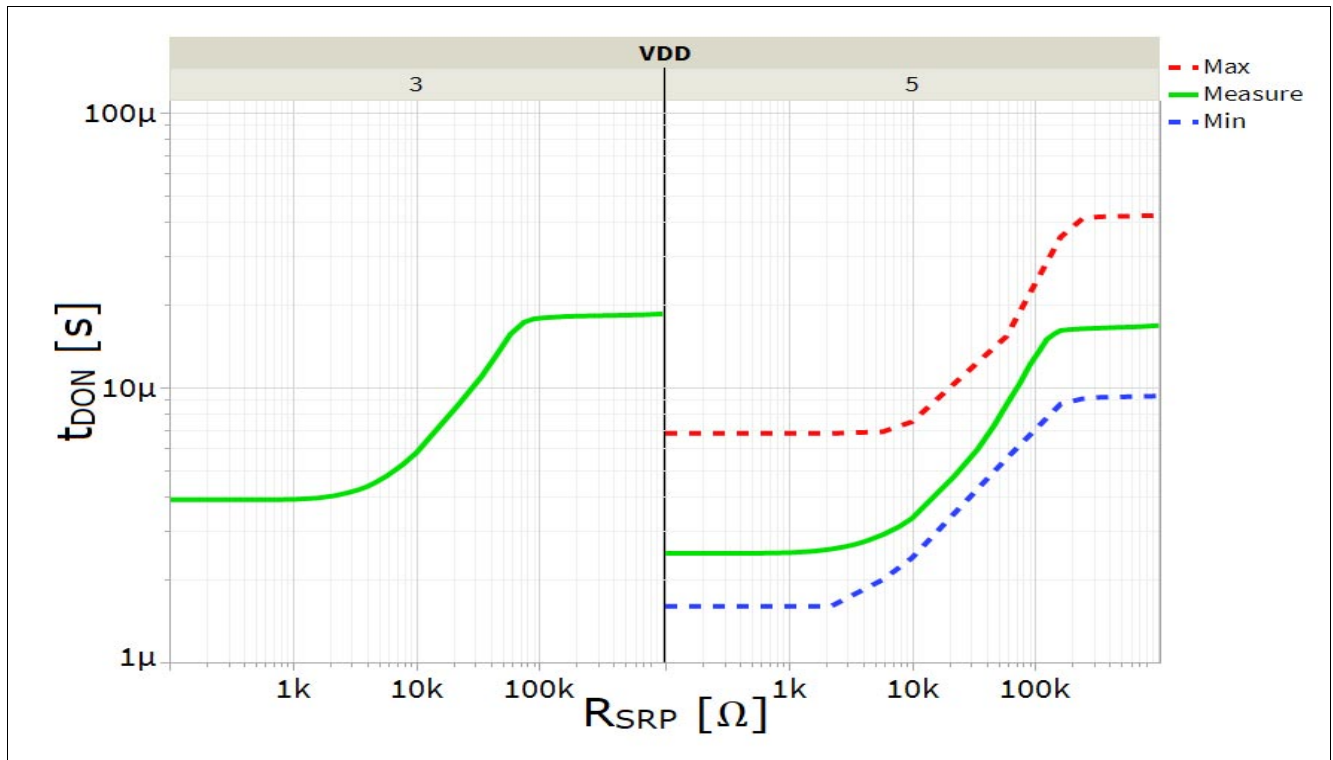

Figure 24 Typical  $t_{DON}$  vs.  $R_{SRP}$  @  $V_{IN} = 5V$ ;  $V_{DD} = 3V, 5V$ ;  $V_{BAT} = 28V$ ;  $R_L = 4.7\Omega$ ;  $T_J = [-40 .. 150^\circ C]$

Characterisation Results

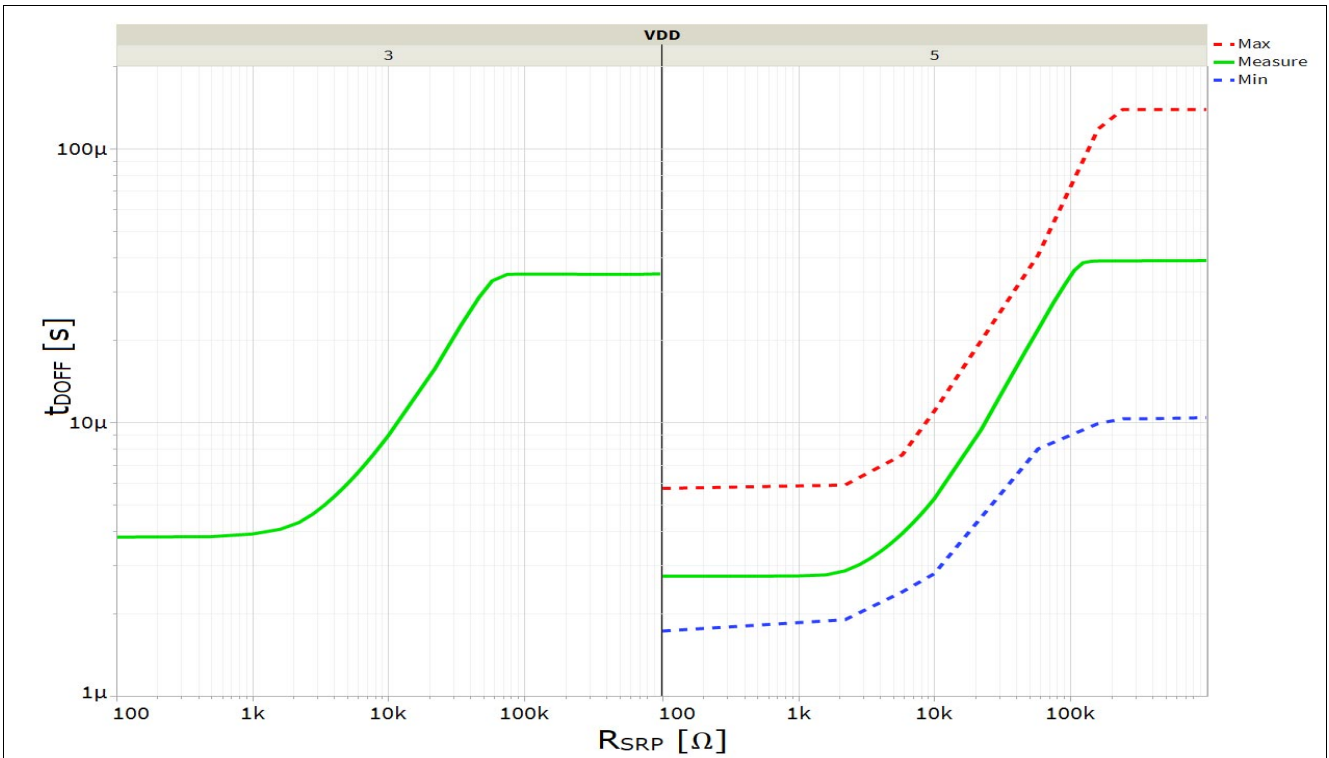

Figure 25 Typical  $t_{DOFF}$  vs.  $R_{SRP}$  @  $V_{IN} = 5V$ ;  $V_{DD} = 3V, 5V$ ;  $V_{BAT} = 28V$ ;  $R_L = 4.7\Omega$ ;  $T_J = [-40 .. 150^\circ C]$

9.2 Protection

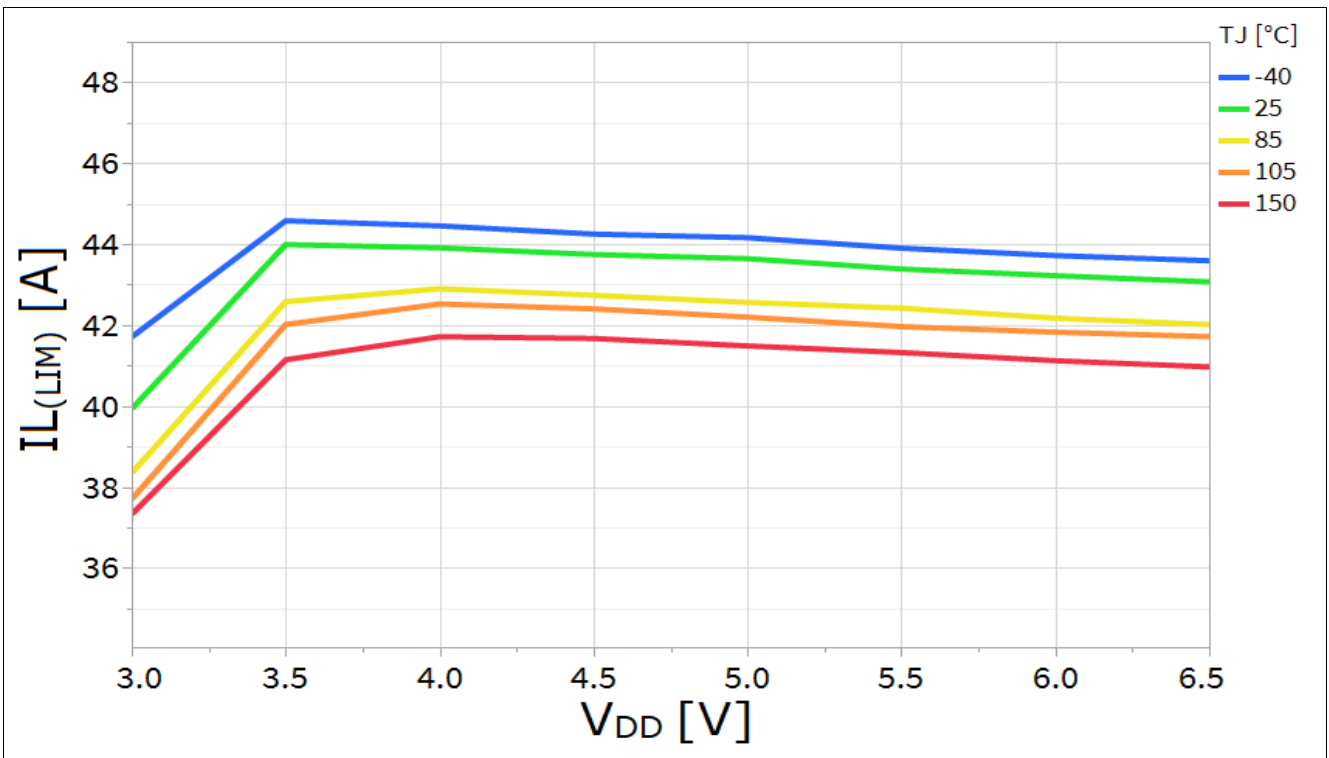

Figure 26 Typical  $I_{L(LIM)}$  vs.  $V_{DD}$ ;  $V_{IN} = 5V$

Characterisation Results

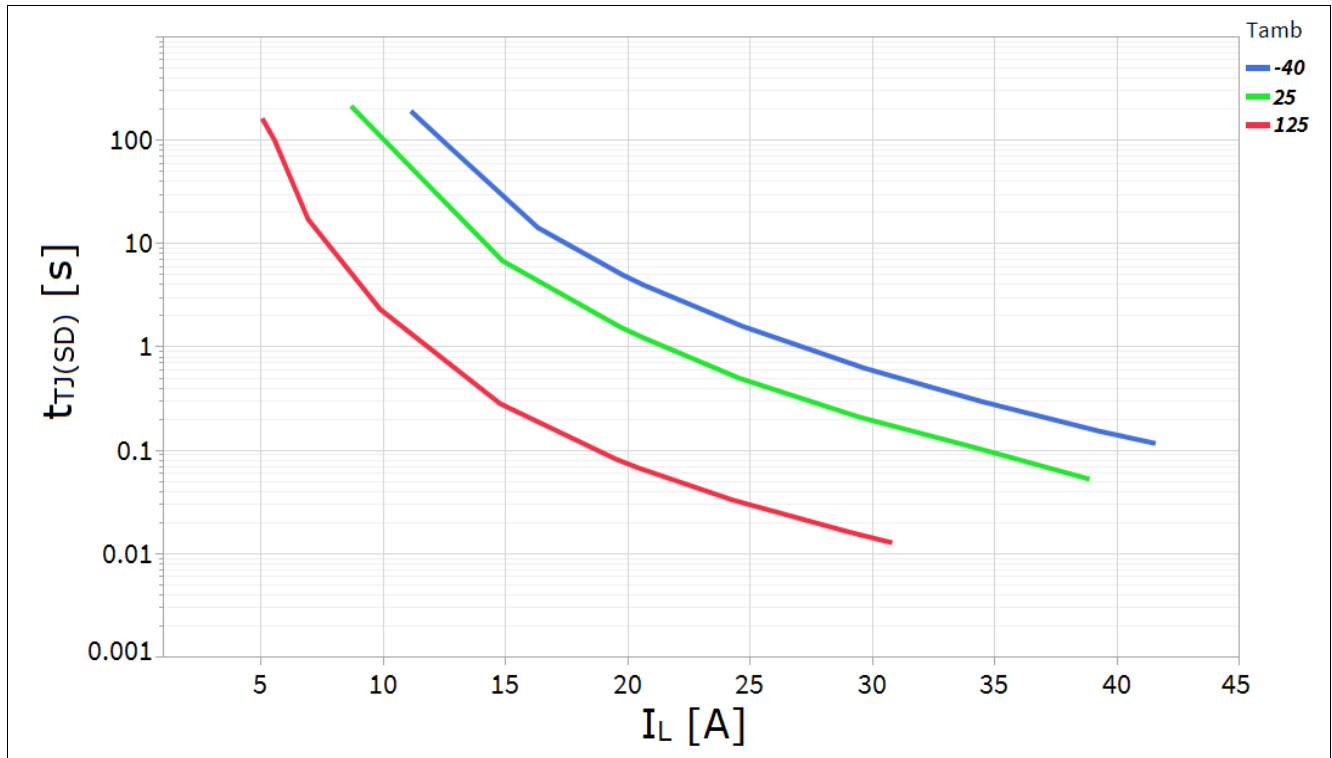

Figure 27 Typical time to shut down  $t_{TJ(SD)}$  vs.  $I_L$ ;  $V_{BAT} = 28V$ ;  $V_{DD} = 5V$ ;  $V_{IN} = 5V$ ;  $R_{thJA}(1sop + 300mm^2)$

9.3 Supply and Input Stage

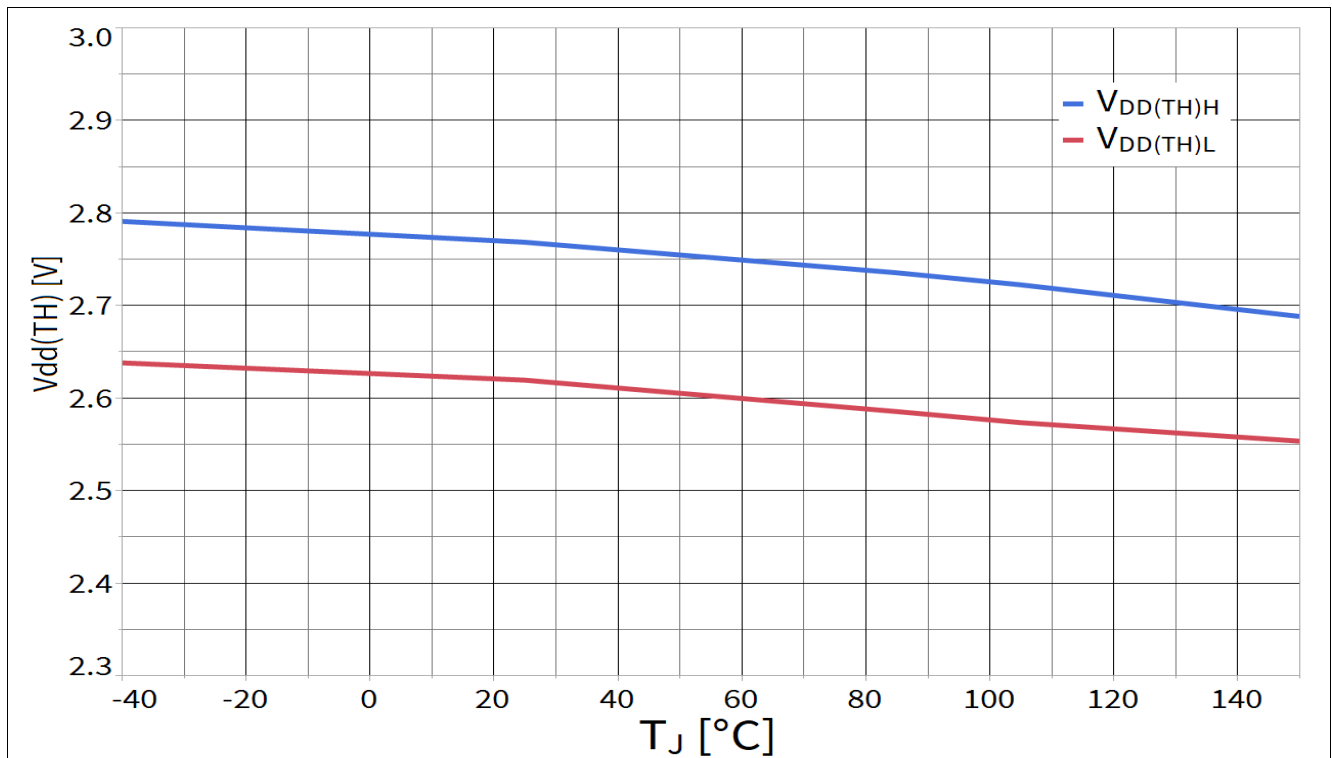

Figure 28 Typical  $V_{DD(TH)}$  vs.  $T_J$ ;  $V_{DD(TH)H}$ ,  $V_{DD(TH)L}$ ;  $V_{IN} = 3V$ ;  $R_{SRP} = GND$ ;  $V_{BAT} = 28V$

Characterisation Results

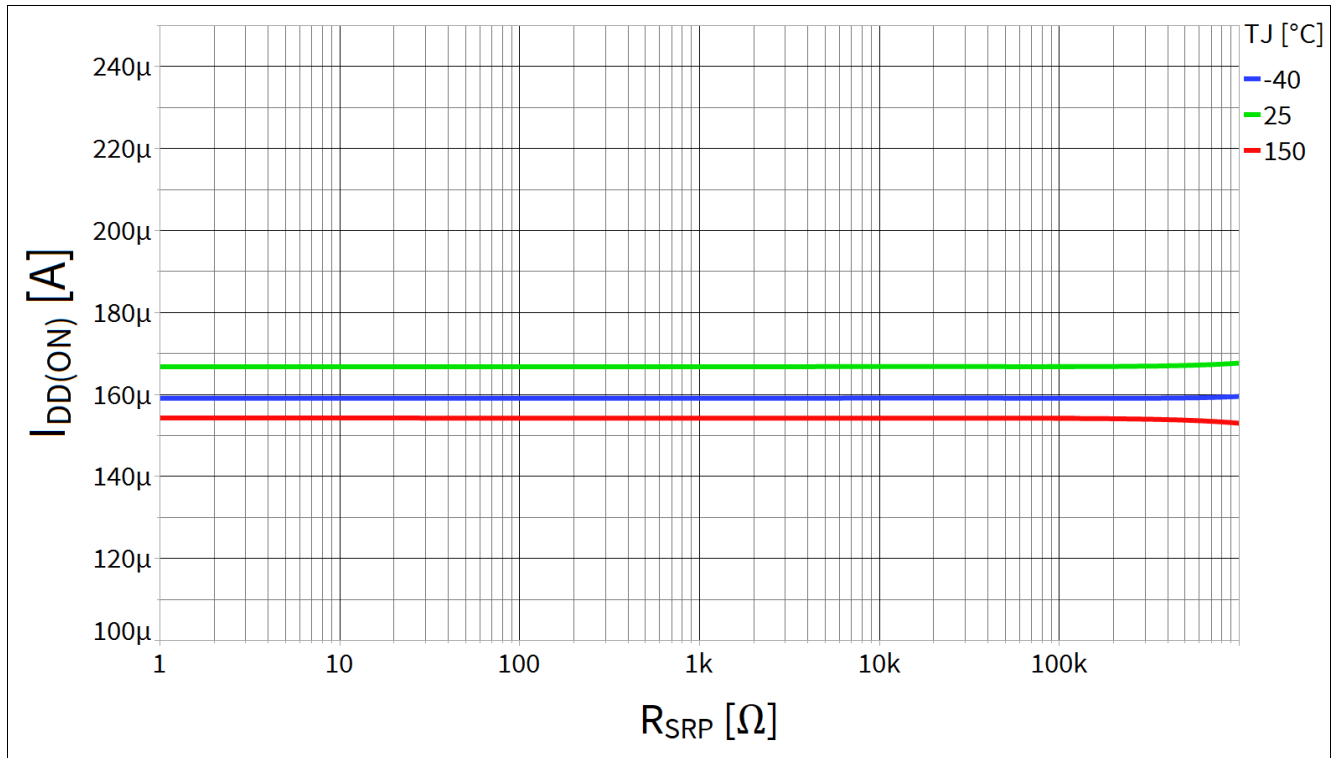

Figure 29 Typical  $I_{DD(ON)}$  vs.  $R_{SRP}$ ;  $I_L = I_{L(NOM)}$ ;  $V_{IN} = 3V$ ;  $V_{DD} = 5V$ ;  $V_{BAT} = 28V$

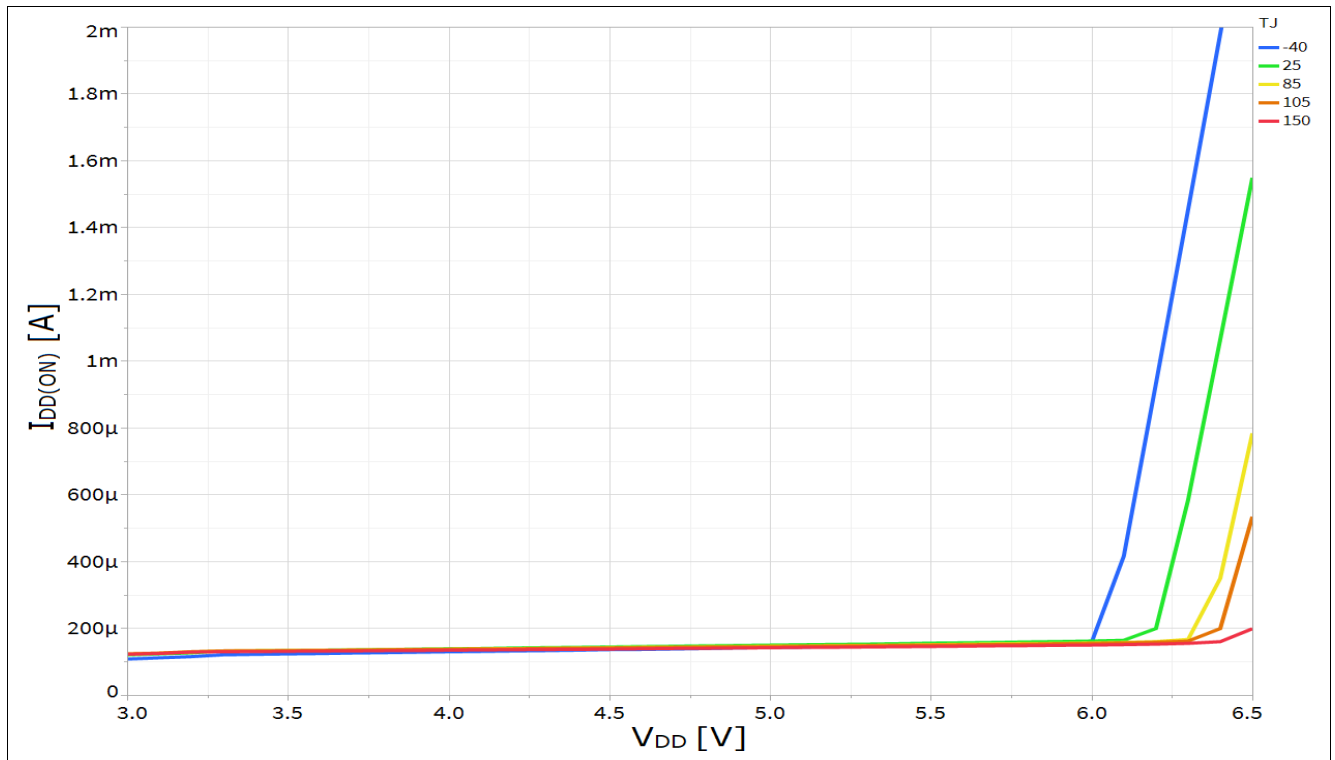

Figure 30 Typical  $I_{DD(ON)}$  vs.  $V_{DD}$ ;  $I_L = I_{L(NOM)}$ ;  $V_{IN} = 3V$ ;  $V_{BAT} = 28V$ ;  $R_{SRP} = GND$

Characterisation Results

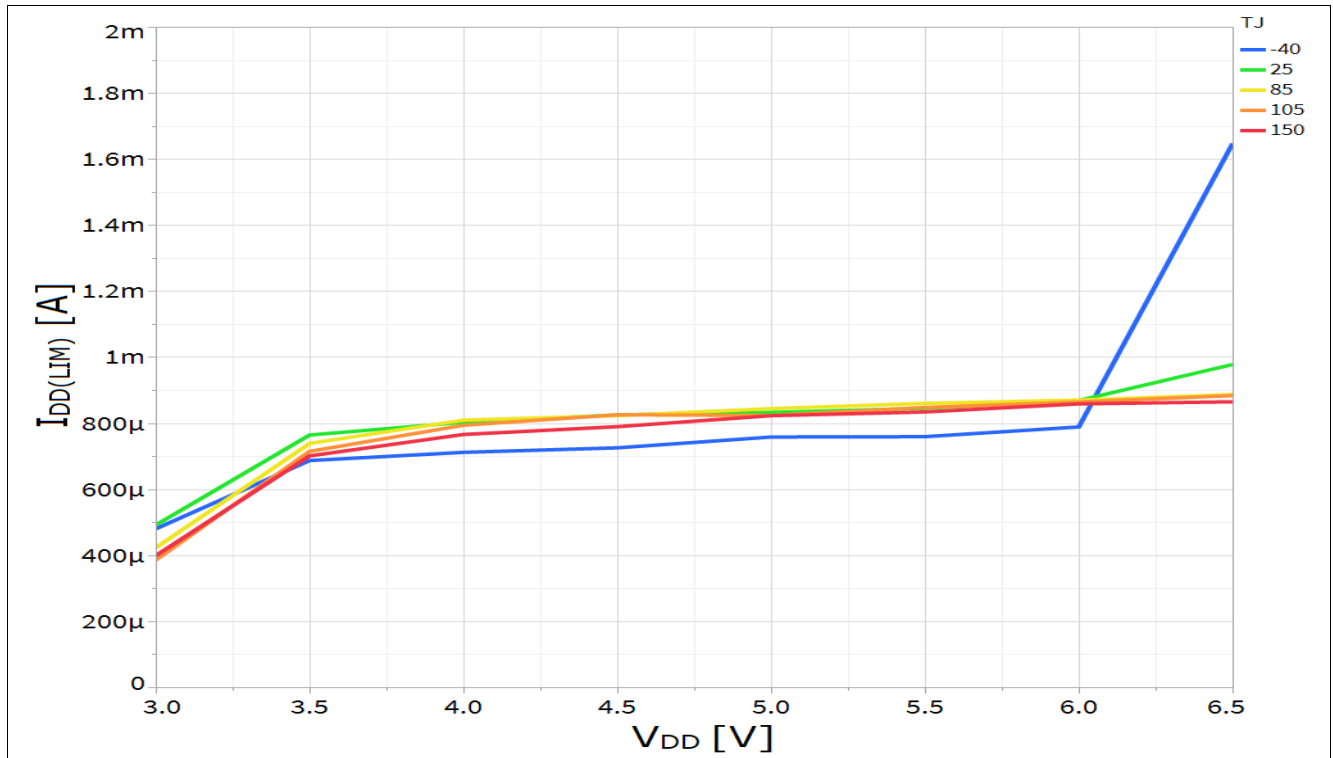

Figure 31 Typical  $I_{DD(LIM)}$  vs.  $V_{DD}$ ;  $V_{IN} = 3V$ ;  $R_{SRP} = GND$ ;  $V_{BAT} = 5V$

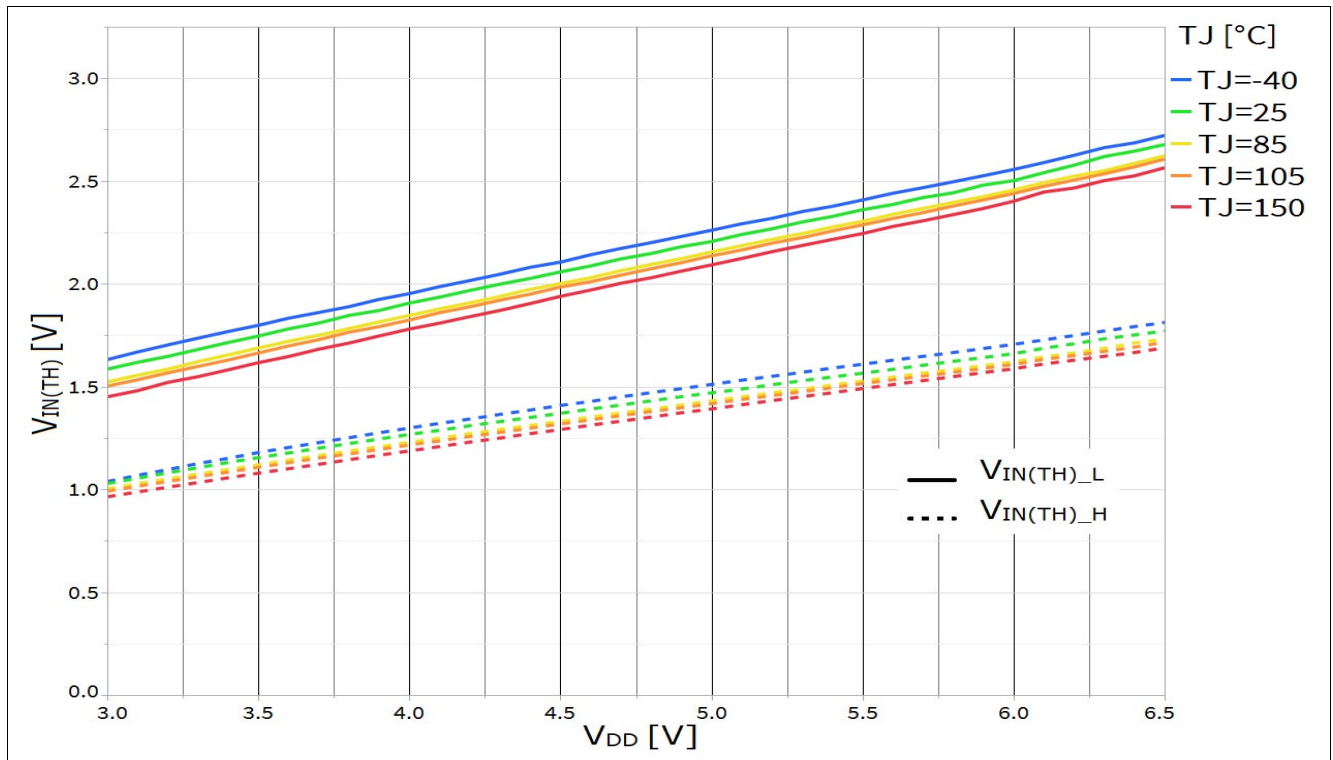

Figure 32 Typical  $V_{IN(TH)}$  vs.  $V_{DD}$ ;  $V_{IN(TH)H}$ ,  $V_{IN(TH)L}$ ;  $R_{LOAD} = 150k\Omega$ ;  $R_{SRP} = GND$ ;  $V_{BAT} = 28V$

## 10 Application Information

### 10.1 Layout recommendations/considerations

As consequences of the fast switching times for high currents ( $I_{NOM}$  and above), special care has to be taken for the PCB layout. Stray inductances have to be minimized. BTT3018EJ has no separate pin for power ground and logic ground.

It is recommended:

- to ensure that the offset between the ground connection of the SRP resistor and ground pins of the device is minimized.  $R_{SRP}$  should be placed next to the device and directly connected to the GND pins, to avoid any influence of GND shift to SRP functionality.

- to ensure that the offset between the ground of the  $V_{DD}$  supply and the ground of the pins of the device is minimized.

The maximum parasitic capacitance between the SRP line and GND ( $C_{SRP}$ ) has to be less than 10pF to avoid any influence on SRP functionality (e.g. switching times).

### 10.2 Application Diagrams

*Note: The following information is given as a hint for the implementation of the device only and shall not be regarded as a description or warranty of a certain functionality, condition or quality of the device.*

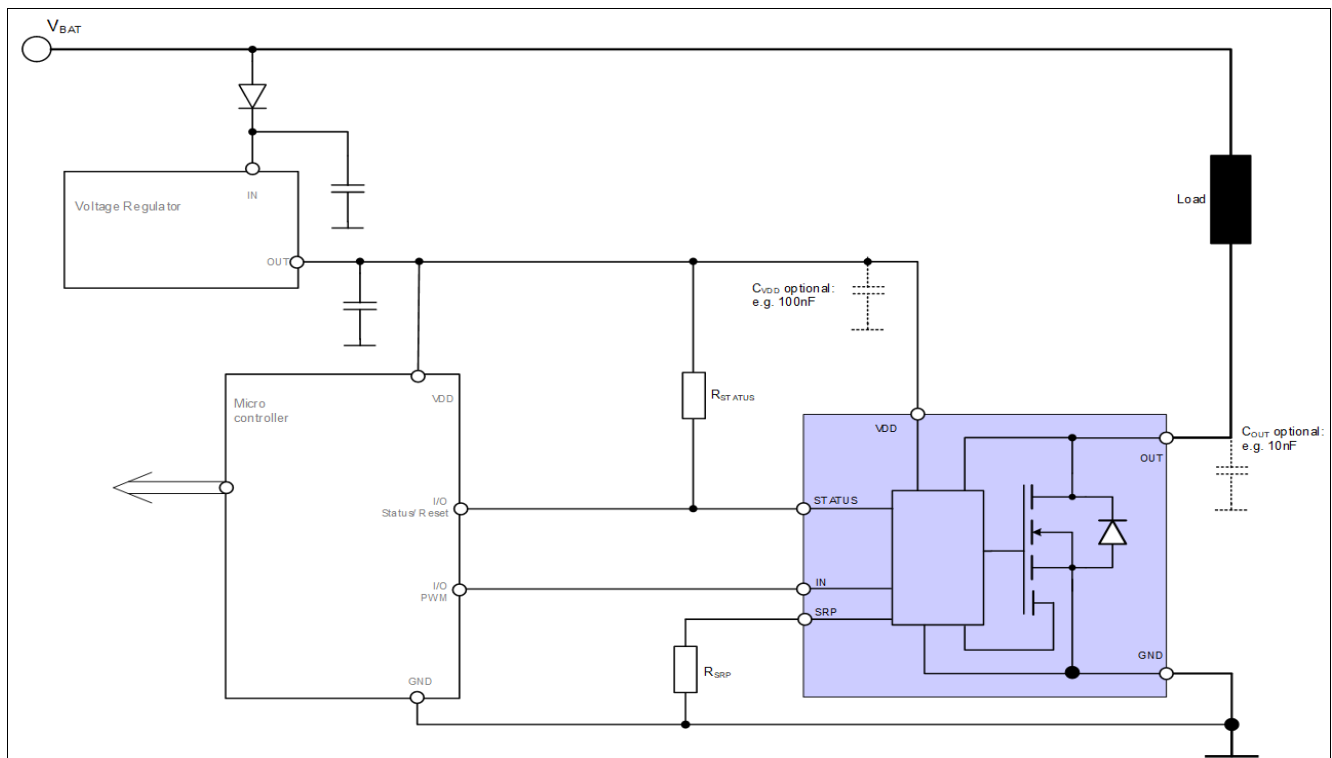

**Figure 33 Application Diagram to use IN pin and STATUS pin independently**

Recommended values for  $V_{IN} = V_{DD} = 5\text{ V}$ :

$$R_{STATUS} = 100\text{ k}\Omega$$

**Application Information**

**Table 9**  $R_{SRP}$  switching modes<sup>1)</sup>

$R_{SRP}$ min	$R_{SRP}$ max	Unit	Behavior
0	2.2	k $\Omega$	Fast switching mode. SRP pin can be connected to GND
2.2	160	k $\Omega$	Adjustable switching mode
160	1000	k $\Omega$	Slow switching mode

1) For switching timings please refer to [Chapter 8.1](#)

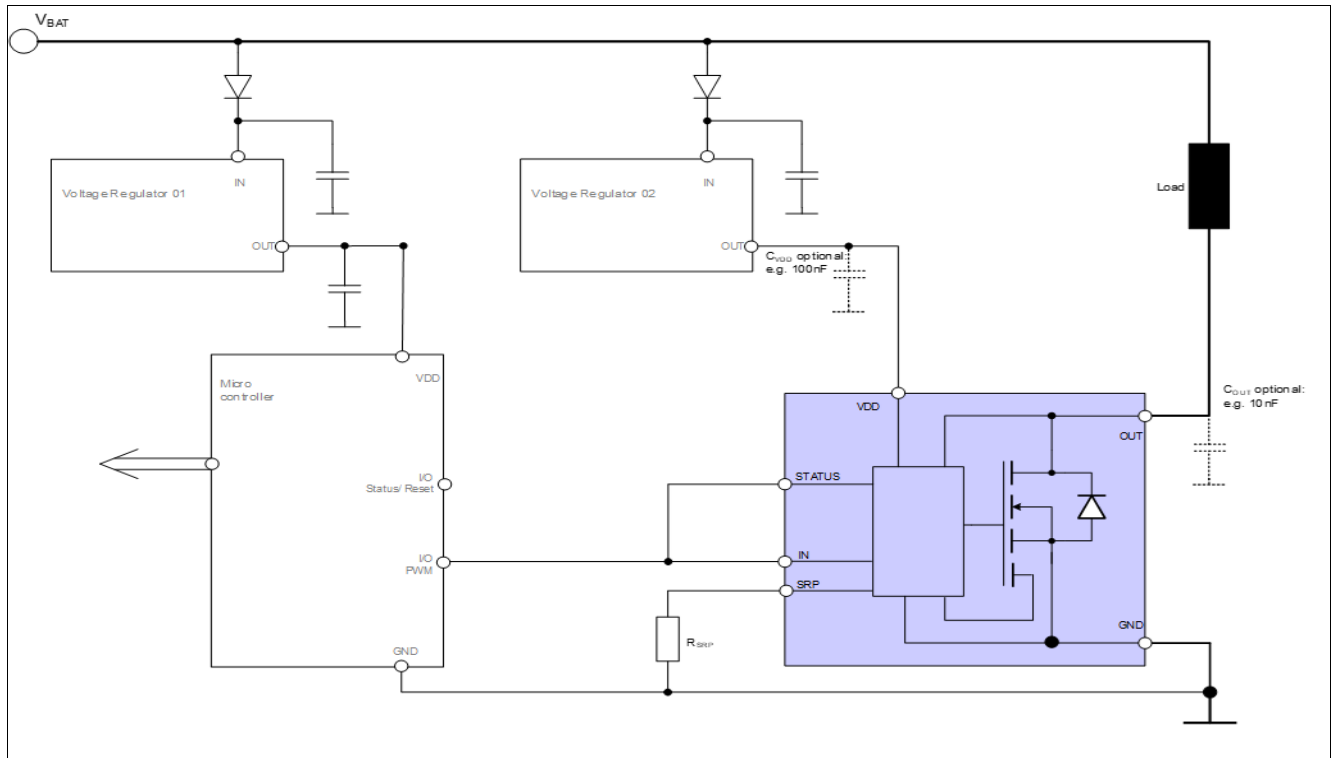

**Figure 34** Application Diagram to use IN pin and STATUS pin simultaneously with different supply and microcontroller voltage class

Example given for  $V_{IN} = 3.3V$ ;  $V_{DD} = 5V$  allows to maintain an optimal  $R_{DS(ON)}$  while driving the input with a 3.3V microcontroller. This configuration makes not possible the readout of the fault signal and will reset the latch OFF via IN pin (see parameters in [Chapter 8.4](#)).

For  $R_{SRP}$  recommended values, please see [Table 9](#)

*Note:* This are very simplified examples of an application circuit. The function must be verified in the real application.

## 11 Package Outlines

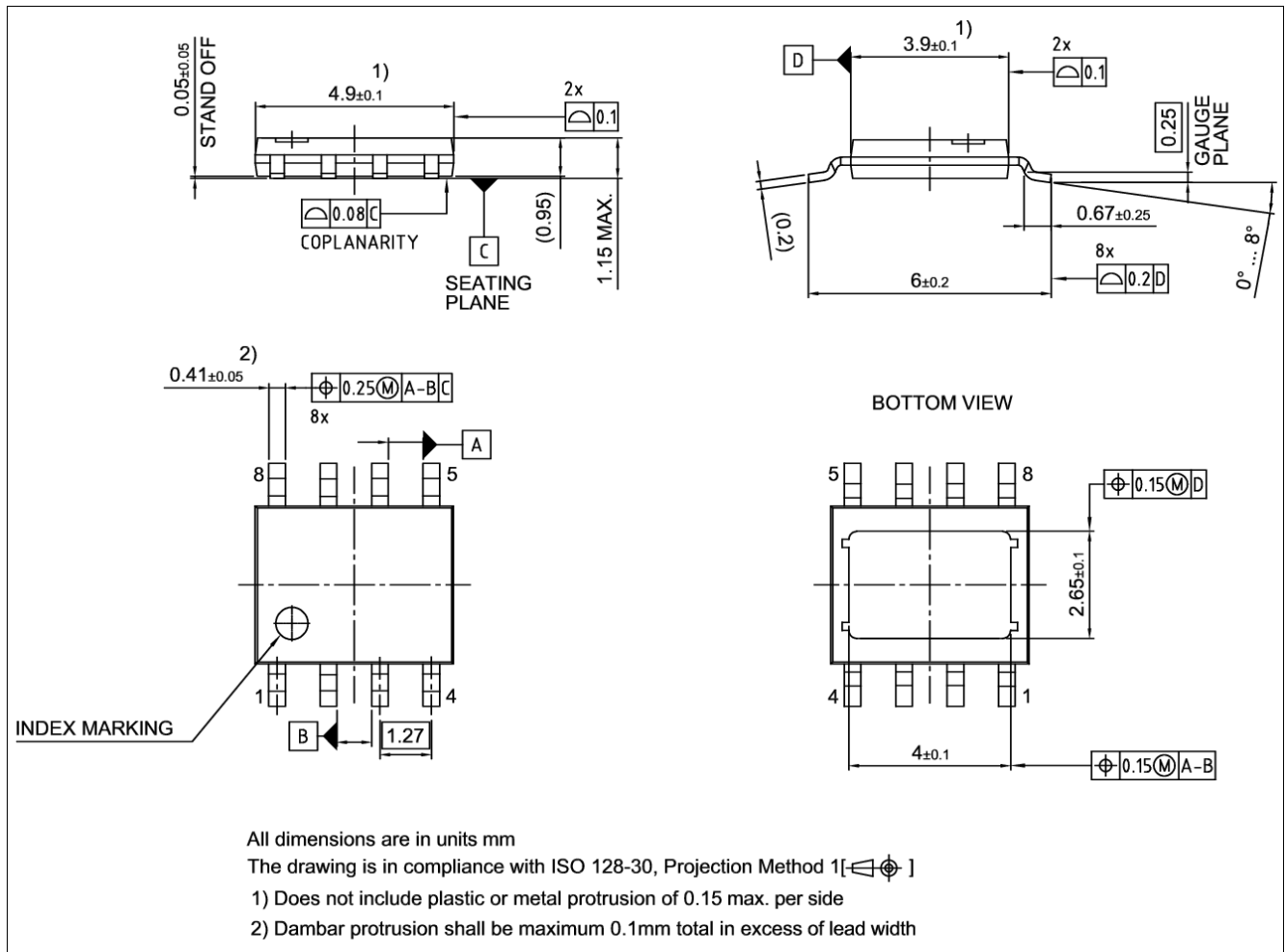

Figure 35 PG-TDSO-8

### Green Product (RoHS compliant)

To meet the world-wide customer requirements for environmentally friendly products and to be compliant with government regulations the device is available as a green product. Green products are RoHS-Compliant (i.e Pb-free finish on leads and suitable for Pb-free soldering according to IPC/JEDEC J-STD-020).

## **12      Revision History**

---

**Revision History**

<b>Revision</b>	<b>Date</b>	<b>Changes</b>
Rev. 1.0	2020-01-17	Initial release

#### Trademarks of Infineon Technologies AG

$\mu$ HVIC™,  $\mu$ IPM™,  $\mu$ PFC™, AU-ConvertIR™, AURIX™, C166™, CanPAK™, CIPOS™, CIPURSE™, CoolDP™, CoolGaN™, COOLIR™, CoolMOS™, CoolSET™, CoolSiC™, DAVE™, DI-POL™, DirectFET™, DrBlade™, EasyPIM™, EconoBRIDGE™, EconoDUAL™, EconoPACK™, EconoPIM™, EiceDRIVER™, eupec™, FCOS™, GaNpowIR™, HEXFET™, HITFET™, HybridPACK™, iMOTION™, IRAM™, ISOFACE™, IsoPACK™, LEDrivr™, LITIX™, MIPAQ™, ModSTACK™, my-d™, NovalithIC™, OPTIGA™, OptiMOS™, ORIGA™, PowIRaudio™, PowIRstage™, PrimePACK™, PrimeSTACK™, PROFET™, PRO-SIL™, RASIC™, REAL3™, SmartLEWIS™, SOLID FLASH™, SPOC™, StrongIRFET™, SupIRBuck™, TEMPFET™, TRENCHSTOP™, TriCore™, UHVIC™, XHP™, XMC™.

Trademarks updated November 2015

#### Other Trademarks

All referenced product or service names and trademarks are the property of their respective owners.

**Edition 2020-01-16**

**Published by**

**Infineon Technologies AG**

**81726 Munich, Germany**

**© 2020 Infineon Technologies AG.**

**All Rights Reserved.**

**Do you have a question about any aspect of this document?**

**Email: [erratum@infineon.com](mailto:erratum@infineon.com)**

#### IMPORTANT NOTICE

The information given in this document shall in no event be regarded as a guarantee of conditions or characteristics ("Beschaffenheitsgarantie").

With respect to any examples, hints or any typical values stated herein and/or any information regarding the application of the product, Infineon Technologies hereby disclaims any and all warranties and liabilities of any kind, including without limitation warranties of non-infringement of intellectual property rights of any third party.

In addition, any information given in this document is subject to customer's compliance with its obligations stated in this document and any applicable legal requirements, norms and standards concerning customer's products and any use of the product of Infineon Technologies in customer's applications.

The data contained in this document is exclusively intended for technically trained staff. It is the responsibility of customer's technical departments to evaluate the suitability of the product for the intended application and the completeness of the product information given in this document with respect to such application.

#### Legal Disclaimer for Short-Circuit Capability

Infineon disclaims any warranties and liabilities, whether expressed or implied, for any short-circuit failures below the threshold limit.

For further information on technology, delivery terms and conditions and prices, please contact the nearest Infineon Technologies Office ([www.infineon.com](http://www.infineon.com)).

#### WARNINGS

Due to technical requirements products may contain dangerous substances. For information on the types in question please contact your nearest Infineon Technologies office.

Except as otherwise explicitly approved by Infineon Technologies in a written document signed by authorized representatives of Infineon Technologies, Infineon Technologies' products may not be used in any applications where a failure of the product or any consequences of the use thereof can reasonably be expected to result in personal injury.