

Communication BUS Varistor

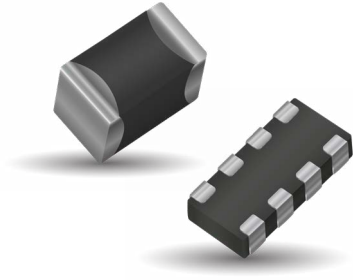

GENERAL DESCRIPTION

The CAN BUS and FlexRay varistor is a zinc oxide (ZnO) based ceramic semiconductor device with non-linear voltage-current characteristics (bi-directional) similar to back-to-back Zener diodes and an EMC capacitor in parallel (see equivalent circuit model). They have the added advantage of greater current and energy handling capabilities as well as EMI/RFI attenuation. Devices are fabricated by a ceramic sintering process that yields a structure of conductive ZnO grains surrounded by electrically insulating barriers, creating varistor like behavior.

KYOCERA AVX Communication Bus Varistors offer the advantages of large in-rush current capability, low capacitance to minimize signal distortion, fast turn on time to conservatively clamp the energy before its maximum and off state EMI filtering through their bulk capacitance. These features coupled with an extremely low FIT rate and excellent process capability make an ideal device for today's automotive or general circuit protection.

GENERAL CHARACTERISTICS

- Operating Temperature: -55°C to +125°C
- Working Voltage: ≤18Vdc
- Case Size: 0402, 0603
 - 0405 2xArray
 - 0612 4xArray

FEATURES

- Compact footprint
- High ESD capability (25kV)
- High Inrush Current (8x20μs)
- EMI/RFI Attenuation
- Low Capacitance/Low Insertion Loss
- Very Fast Response Time
- High Reliability <0.1 FIT
- AEC-Q200 Qualified

APPLICATIONS

- Communication Bus: CAN Bus, FlexRay, etc.
- General I/O Protocols
- Keyboard Interfaces
- Datalines
- Sensors
- Capacitance sensitive applications and more

HOW TO ORDER

CAN	0001	D	P	
Style	Case Size	Packaging Code (Reel Size)	Termination	
CAN = CAN BUS FLX = FlexRay	0001 = 0603 Discrete 0002 = 0405 2-Element 0003 = 0405 2-Element 0004 = 0612 4-Element 0005 = 0402 Discrete 0007 = 0603 Discrete	D = 7" reel (1,000 pcs.) R = 7" reel (4,000 pcs.) T = 13" reel (10,000 pcs.) W = 7" reel (10,000 pcs.) 0402 only	P = Ni/Sn (Plated)	

PERFORMANCE CHARACTERISTICS

Part Number	V _w (DC)	V _w (AC)	V _B	V _C	I _{vc}	I _L	E _T	I _p	Cap	Freq	VJump	PDiss Max	Case	Elements
CAN0001 __	≤ 18	≤ 14	120	225	1	2	0.015	4	22 Max	M	27.5	0.003	0603	1
CAN0002 __	≤ 18	≤ 14	70	145	1	2	0.015	4	22 Max	M	27.5	0.003	0405	2
CAN0003 __	≤ 18	≤ 14	28.5	50	1	5	0.02	15	50 Max	M	27.5	0.0008	0405	2
CAN0004 __	≤ 18	≤ 14	100	180	1	2	0.015	4	22 Max	M	27.5	0.003	0612	4
CAN0005 __	≤ 18	≤ 14	33	55	1	2	0.05	10	37 Max	M	27.5	0.01	0402	1
CAN0007 __	≤ 32.0	≤ 25.0	61	120	1	5	0.05	5	15 Max	M	27.5	0.003	0603	1
FLX0005 __	≤ 18	≤ 14	26	45	1	5	0.02	4	17 Max	M	27.5	0.004	0402	1

Termination Finish Code
Packaging Code

- | | | | |
|---------------------|---------------------------------------|----------------|---|
| V _w (DC) | DC Working Voltage (V) | I _L | Maximum Leakage Current at the Working Voltage (μA) |
| V _w (AC) | AC Working Voltage (V) | E _T | Transient Energy Rating (J, 10x1000μS) |
| V _B | Typical Breakdown Voltage (V @ 1mADC) | I _p | Peak Current Rating (A, 8x20μS) |
| V _C | Clamping Voltage (V @ IVC) | Cap | Maximum Capacitance (pF) @ 1 MHz and 0.5Vrms |
| I _{vc} | Test Current for VC (A, 8x20μS) | Temp Range | -55°C to +125°C |

Communication BUS Varistor

S21 CHARACTERISTICS

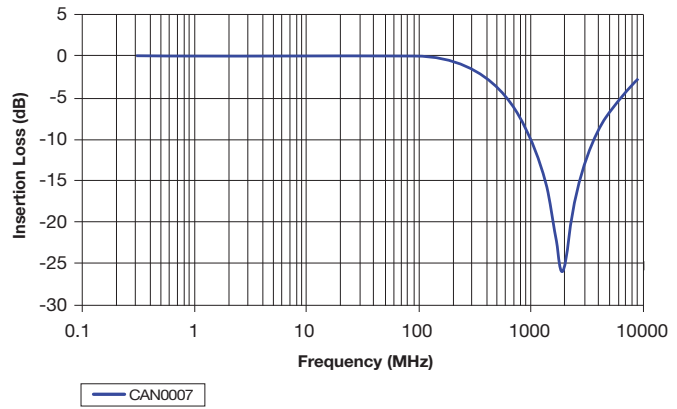
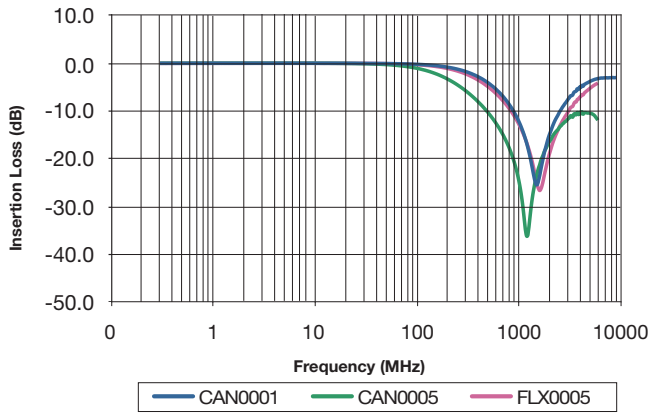

TYPICAL MLV IMPLEMENTATION

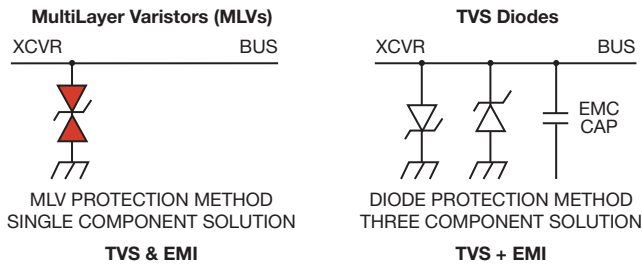

TYPICAL PULSE RATING CURVE

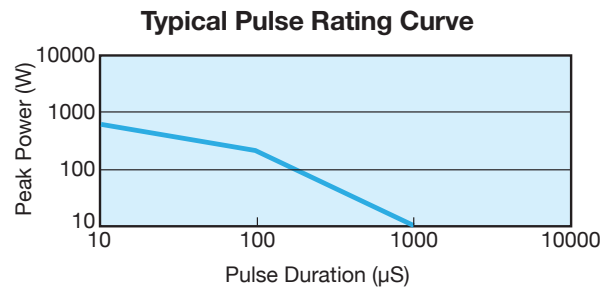

EQUIVALENT CIRCUIT MODEL

Discrete MLV Model

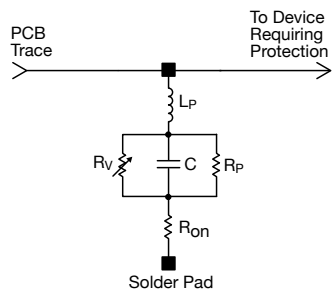

Where:

- R_v = Voltage Variable resistance (per VI curve)
- $R_p \geq 1012 \Omega$
- C = defined by voltage rating and energy level
- R_{on} = turn on resistance
- L_p = parallel body inductance

Communication BUS Varistor

TYPICAL CAN BUS IMPLEMENTATION SCHEME

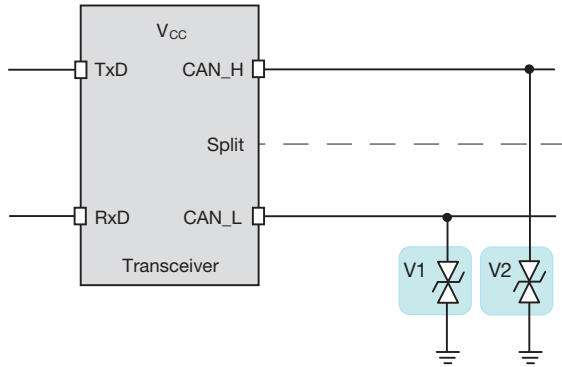

TYPICAL FLEX RAY IMPLEMENTATION SCHEME

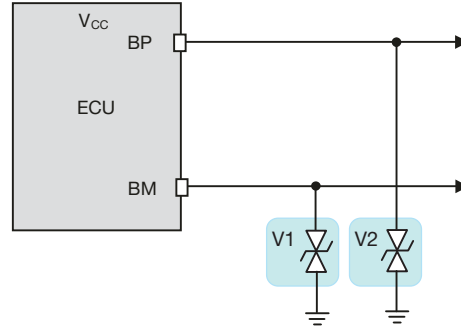

PHYSICAL DIMENSIONS

mm (inches)

	0402 Discrete	0603 Discrete	0405 Array	0612 Array
Length	1.00 ±0.10 (0.040 ±0.004)	1.60 ±0.15 (0.063 ±0.006)	1.00 ±0.15 (0.039 ±0.006)	1.60 ±0.20 (0.063 ±0.008)
Width	0.50 ±0.10 (0.020 ±0.004)	0.80 ±0.15 (0.032 ±0.006)	1.37 ±0.15 (0.054 ±0.006)	3.20 ±0.20 (0.126 ±0.008)
Thickness	0.60 Max. (0.024 Max.)	0.90 Max. (0.035 Max.)	0.66 Max. (0.026 Max.)	1.22 Max. (0.048 Max.)
Term Band Width	0.25 ±0.15 (0.010 ±0.006)	0.35 ±0.15 (0.014 ±0.006)	0.36 ±0.10 (0.014 ±0.004)	0.41 ±0.10 (0.016 ±0.010)

SOLDER PAD DIMENSIONS

mm (inches)

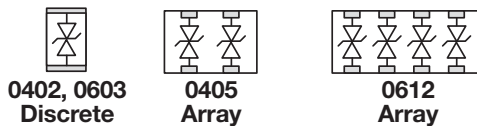
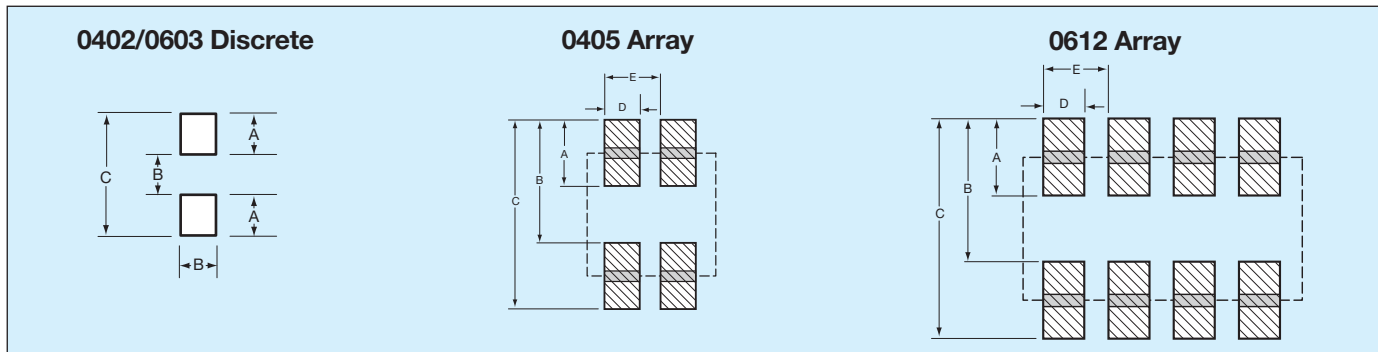

	A	B	C	D	E
0402 Discrete	0.61 (0.024)	0.51 (0.020)	1.70 (0.067)	-	-
0603 Discrete	0.89 (0.035)	0.76 (0.030)	2.54 (0.100)	-	-
0405 Array	0.46 (0.018)	0.74 (0.029)	0.12 (0.047)	0.38 (0.015)	0.64 (0.025)
0612 Array	0.89 (0.035)	1.65 (0.065)	2.54 (0.100)	0.46 (0.018)	0.76 (0.030)

Communication BUS Varistor

APPLICATION

KYOCERA AVX CAN BUS and FlexRay varistors offer significant advantages in general areas of a typical CAN or FlexRay network as shown on the right. Some of the advantages over diodes include:

- space savings
- higher ESD capability @ 25kV contact
- higher in rush current (4A) 8 x 20µS
- FIT rate ≤0.1 failures (per billion hours)

