

HEF4528-Q100B

Dual monostable multivibrator

Rev. 2 — 4 March 2022

Product data sheet

1. General description

The HEF4528B-Q100 is a dual retriggerable-resettable monostable multivibrator. Each multivibrator has an active LOW input ($n\bar{A}$), and active HIGH input (nB), an active LOW clear direct input ($n\bar{C}\bar{D}$), an output (nQ) and its complement ($n\bar{Q}$), and two external timing component connecting pins (nC_{EXT} , always connected to ground, and nR_{EXT}/C_{EXT}).

An external timing capacitor (C_{EXT}) must be connected between nC_{EXT} and nR_{EXT}/C_{EXT} and an external resistor (R_{EXT}) must be connected between nR_{EXT}/C_{EXT} and V_{DD} . The output pulse duration is determined by the external timing components C_{EXT} and R_{EXT} . A HIGH-to-LOW transition on $n\bar{A}$ when nB is LOW or a LOW-to-HIGH transition on nB when $n\bar{A}$ is HIGH produces a positive pulse (LOW-HIGH-LOW) on nQ and a negative pulse (HIGH-LOW-HIGH) on $n\bar{Q}$ if the $n\bar{C}\bar{D}$ is HIGH. A LOW on $n\bar{C}\bar{D}$ forces nQ LOW, $n\bar{Q}$ HIGH and inhibits any further pulses until $n\bar{C}\bar{D}$ is HIGH.

It operates over a recommended V_{DD} power supply range of 3 V to 15 V referenced to V_{SS} (usually ground). Unused inputs must be connected to V_{DD} , V_{SS} , or another input.

This product has been qualified to the Automotive Electronics Council (AEC) standard Q100 (Grade 3) and is suitable for use in automotive applications.

2. Features and benefits

- Automotive product qualification in accordance with AEC-Q100 (Grade 3)
 - Specified from -40 °C to +85 °C
- Fully static operation
- Wide supply voltage range from 3.0 V to 15.0 V
- CMOS low power dissipation
- High noise immunity
- 5 V, 10 V, and 15 V parametric ratings
- Standardized symmetrical output characteristics
- ESD protection:
 - MIL-STD-883, method 3015 exceeds 2000 V
 - HBM JESD22-A114F exceeds 2000 V
 - MM JESD22-A115-A exceeds 200 V ($C = 200$ pF, $R = 0$ Ω)
- Complies with JEDEC standard JESD 13-B

3. Ordering information

Table 1. Ordering information

Type number	Package			
	Temperature range	Name	Description	Version
HEF4528BT-Q100	40 °C to +85 °C	SO16	plastic small outline package; 16 leads; body width 3.9 mm	SOT109-1

4. Functional diagram

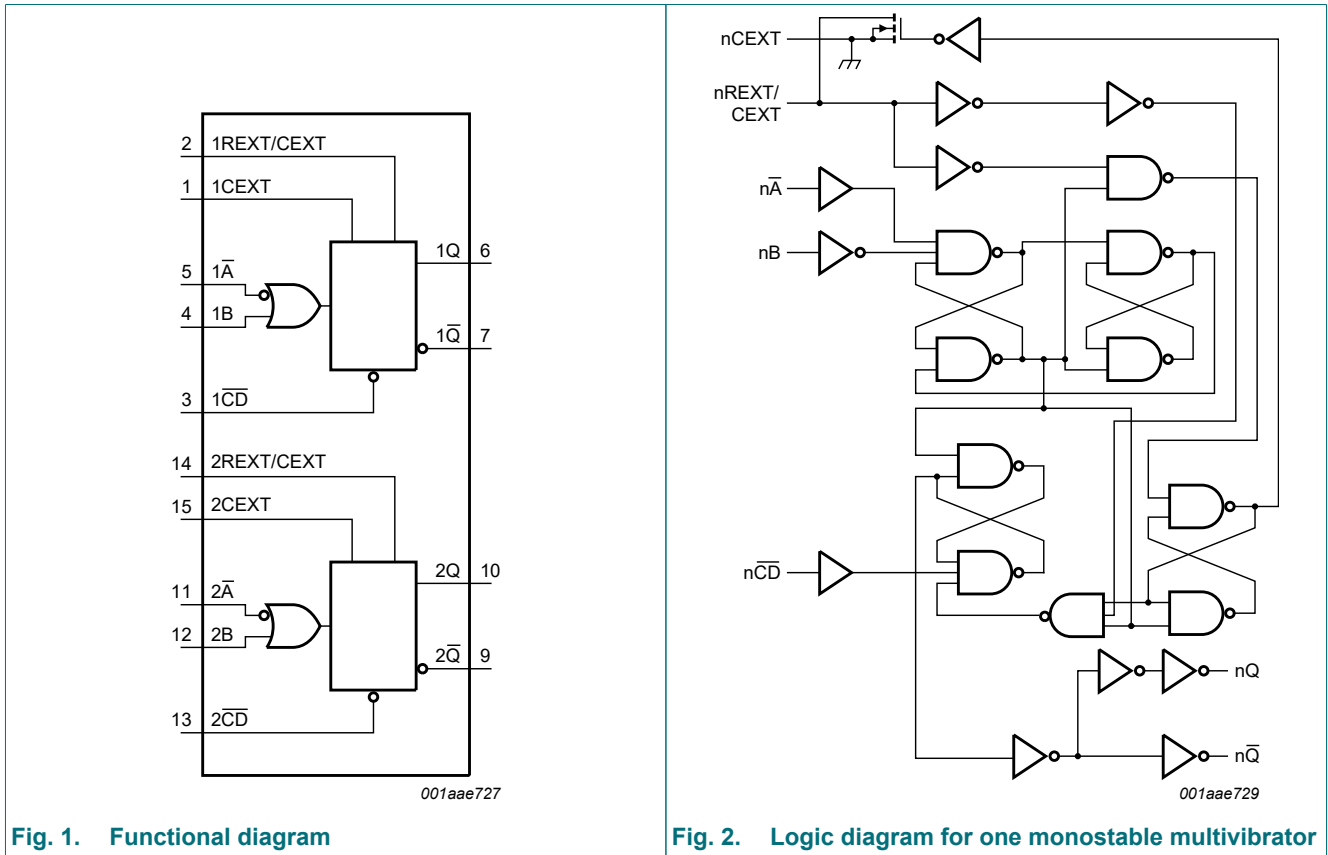

Fig. 1. Functional diagram

Fig. 2. Logic diagram for one monostable multivibrator

5. Pinning information

5.1. Pinning

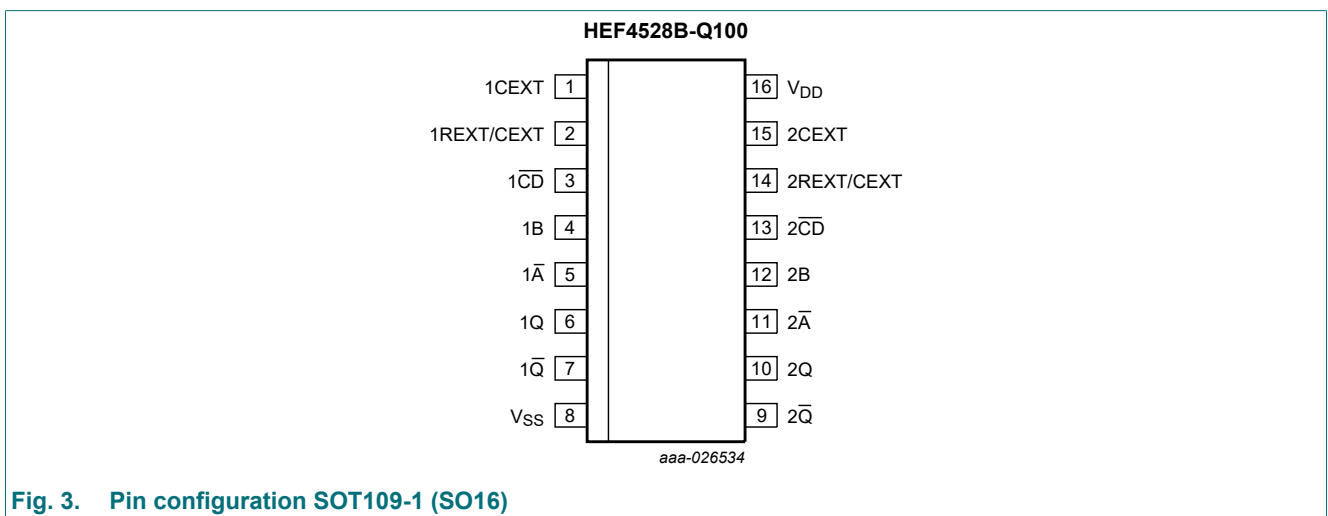

Fig. 3. Pin configuration SOT109-1 (SO16)

5.2. Pin description

Table 2. Pin description

Symbol	Pin	Description
1CEXT, 2CEXT	1, 15	external capacitor connection (always connected to ground)
1REXT/CEXT, 2REXT/CEXT	2, 14	external capacitor/resistor connection
1 \overline{CD} , 2 \overline{CD}	3, 13	clear direct input (active LOW)
1B, 2B	4, 12	input (LOW-to-HIGH triggered)
1 \overline{A} , 2 \overline{A}	5, 11	input (HIGH-to-LOW triggered)
1Q, 2Q	6, 10	output
1 \overline{Q} , 2 \overline{Q}	7, 9	complementary output (active LOW)
V _{SS}	8	ground supply voltage
V _{DD}	16	supply voltage

6. Functional description





Table 3. Function table

H = HIGH voltage level; L = LOW voltage level; X = don't care;

↑ = positive-going transition; ↓ = negative-going transition;

 = one HIGH level output pulse, with the pulse width determined by C_{EXT} and R_{EXT};

 = one LOW level output pulse, with the pulse width determined by C_{EXT} and R_{EXT}.

Inputs			Outputs	
A	B	CD	Q	\overline{Q}
↓	L	H		
H	↑	H		
X	X	L	L	H

7. Limiting values

Table 4. Limiting values

In accordance with the Absolute Maximum Rating System (IEC 60134). Voltages are referenced to V_{SS} = 0 V (ground).

Symbol	Parameter	Conditions	Min	Max	Unit
V _{DD}	supply voltage		-0.5	+18	V
I _{IK}	input clamping current	V _I < -0.5 V or V _I > V _{DD} + 0.5 V	-	±10	mA
V _I	input voltage		-0.5	V _{DD} + 0.5	V
I _{OK}	output clamping current	V _O < -0.5 V or V _O > V _{DD} + 0.5 V	-	±10	mA
I _{I/O}	input/output current		-	±10	mA
I _{DD}	supply current		-	50	mA
T _{stg}	storage temperature		-65	+150	°C
T _{amb}	ambient temperature		-40	+85	°C
P _{tot}	total power dissipation	T _{amb} = -40 °C to +85 °C	-	500	mW
P	power dissipation	per output	-	100	mW

8. Recommended operating conditions

Table 5. Recommended operating conditions

Symbol	Parameter	Conditions	Min	Max	Unit
V_{DD}	supply voltage		3	15	V
V_I	input voltage		0	V_{DD}	V
T_{amb}	ambient temperature	in free air	-40	+85	°C
$\Delta t/\Delta V$	input transition rise and fall rate	$V_{DD} = 5\text{ V}$	-	3.75	$\mu\text{s/V}$
		$V_{DD} = 10\text{ V}$	-	0.5	$\mu\text{s/V}$
		$V_{DD} = 15\text{ V}$	-	0.08	$\mu\text{s/V}$

9. Static characteristics

Table 6. Static characteristics

$V_{SS} = 0\text{ V}$; $V_I = V_{SS}$ or V_{DD} , unless otherwise specified.

Symbol	Parameter	Conditions	V_{DD}	$T_{amb} = -40\text{ °C}$		$T_{amb} = 25\text{ °C}$		$T_{amb} = 85\text{ °C}$		Unit
				Min	Max	Min	Max	Min	Max	
V_{IH}	HIGH-level input voltage	$ I_O < 1\ \mu\text{A}$	5 V	3.5	-	3.5	-	3.5	-	V
			10 V	7.0	-	7.0	-	7.0	-	V
			15 V	11.0	-	11.0	-	11.0	-	V
V_{IL}	LOW-level input voltage	$ I_O < 1\ \mu\text{A}$	5 V	-	1.5	-	1.5	-	1.5	V
			10 V	-	3.0	-	3.0	-	3.0	V
			15 V	-	4.0	-	4.0	-	4.0	V
V_{OH}	HIGH-level output voltage	$ I_O < 1\ \mu\text{A}$	5 V	4.95	-	4.95	-	4.95	-	V
			10 V	9.95	-	9.95	-	9.95	-	V
			15 V	14.95	-	14.95	-	14.95	-	V
V_{OL}	LOW-level output voltage	$ I_O < 1\ \mu\text{A}$	5 V	-	0.05	-	0.05	-	0.05	V
			10 V	-	0.05	-	0.05	-	0.05	V
			15 V	-	0.05	-	0.05	-	0.05	V
I_{OH}	HIGH-level output current	$V_O = 2.5\text{ V}$	5 V	-	-1.7	-	-1.4	-	-1.1	mA
		$V_O = 4.6\text{ V}$	5 V	-	-0.52	-	-0.44	-	-0.36	mA
		$V_O = 9.5\text{ V}$	10 V	-	-1.3	-	-1.1	-	-0.9	mA
		$V_O = 13.5\text{ V}$	15 V	-	-3.6	-	-3.0	-	-2.4	mA
I_{OL}	LOW-level output current	$V_O = 0.4\text{ V}$	5 V	0.52	-	0.44	-	0.36	-	mA
		$V_O = 0.5\text{ V}$	10 V	1.3	-	1.1	-	0.9	-	mA
		$V_O = 1.5\text{ V}$	15 V	3.6	-	3.0	-	2.4	-	mA
I_I	input leakage current		15 V	-	± 0.3	-	± 0.3	-	± 1.0	μA
I_{DD}	supply current	all valid input combinations; $I_O = 0\text{ A}$	5 V	-	20	-	20	-	150	μA
			10 V	-	40	-	40	-	300	μA
			15 V	-	80	-	80	-	600	μA
C_I	input capacitance		-	-	-	-	7.5	-	-	pF

10. Dynamic characteristics

Table 7. Dynamic characteristics

$V_{SS} = 0\text{ V}$; $T_{amb} = 25\text{ °C}$; unless otherwise specified; for waveforms see Fig. 4 to Fig. 6; for test circuit see Fig. 7.

Symbol	Parameter	Conditions	V _{DD}	Extrapolation formula [1]	Min	Typ	Max	Unit
t _{PHL}	HIGH to LOW propagation delay	n \bar{A} or nB to n \bar{Q} ; see Fig. 5	5 V	$113\text{ ns} + (0.55\text{ ns/pF})C_L$	-	140	280	ns
			10 V	$39\text{ ns} + (0.23\text{ ns/pF})C_L$	-	50	100	ns
			15 V	$27\text{ ns} + (0.16\text{ ns/pF})C_L$	-	35	70	ns
		n $\bar{C}\bar{D}$ to nQ; see Fig. 5	5 V	$78\text{ ns} + (0.55\text{ ns/pF})C_L$	-	105	210	ns
			10 V	$29\text{ ns} + (0.23\text{ ns/pF})C_L$	-	40	85	ns
			15 V	$22\text{ ns} + (0.16\text{ ns/pF})C_L$	-	30	60	ns
t _{PLH}	LOW to HIGH propagation delay	n \bar{A} or nB to nQ; see Fig. 5	5 V	$128\text{ ns} + (0.55\text{ ns/pF})C_L$	-	155	305	ns
			10 V	$49\text{ ns} + (0.23\text{ ns/pF})C_L$	-	60	115	ns
			15 V	$32\text{ ns} + (0.16\text{ ns/pF})C_L$	-	40	80	ns
		n $\bar{C}\bar{D}$ to n \bar{Q} ; see Fig. 5	5 V	$93\text{ ns} + (0.55\text{ ns/pF})C_L$	-	120	240	ns
			10 V	$39\text{ ns} + (0.23\text{ ns/pF})C_L$	-	50	105	ns
			15 V	$27\text{ ns} + (0.16\text{ ns/pF})C_L$	-	35	70	ns
t _t	transition time	nQ, n \bar{Q} ; see Fig. 5	5 V [2]	$10\text{ ns} + (1.00\text{ ns/pF})C_L$	-	60	120	ns
			10 V	$9\text{ ns} + (0.42\text{ ns/pF})C_L$	-	30	60	ns
			15 V	$6\text{ ns} + (0.28\text{ ns/pF})C_L$	-	20	40	ns
t _{rec}	recovery time	n $\bar{C}\bar{D}$ to n \bar{A} or nB; see Fig. 6	5 V		0	-75	-	ns
			10 V		0	-30	-	ns
			15 V		0	-25	-	ns
t _{su}	set-up time	n $\bar{C}\bar{D}$ to n \bar{A} or nB; see Fig. 6	5 V		0	-105	-	ns
			10 V		0	-40	-	ns
			15 V		0	-25	-	ns
t _w	pulse width	n \bar{A} LOW; minimum width; see Fig. 6	5 V		50	25	-	ns
			10 V		30	15	-	ns
			15 V		20	10	-	ns
		nB HIGH; minimum width; see Fig. 6	5 V		50	25	-	ns
			10 V		30	15	-	ns
			15 V		20	10	-	ns
		n $\bar{C}\bar{D}$ LOW; minimum width; see Fig. 6	5 V		60	30	-	ns
			10 V		35	15	-	ns
			15 V		25	10	-	ns
		nQ or n \bar{Q} ; R _{EXT} = 5 k Ω ; C _{EXT} = 15 pF; see Fig. 6	5 V [3]		-	235	-	ns
			10 V		-	155	-	ns
			15 V		-	140	-	ns
nQ or n \bar{Q} ; R _{EXT} = 10 k Ω ; C _{EXT} = 1 nF; see Fig. 6	5 V [4]		-	5.45	-	μs		
	10 V		-	4.95	-	μs		
	15 V		-	4.85	-	μs		

Symbol	Parameter	Conditions	V _{DD}	Extrapolation formula [1]	Min	Typ	Max	Unit
Δt _W	pulse width variation	nQ output variation over temperature range	5 V [5]		-	±3	-	%
			10 V		-	±2	-	%
			15 V		-	±2	-	%
		nQ output variation over voltage range V _{DD} ± 5 %	5 V		-	±2	-	%
			10 V		-	±1	-	%
			15 V		-	±1	-	%
R _{EXT}	external timing resistor	see Fig. 4	5 V		5	-	2	MΩ
			10 V		5	-	2	MΩ
			15 V		5	-	2	MΩ
C _{EXT}	external timing capacitor	see Fig. 4	5 V		no limits			
			10 V		no limits			
			15 V		no limits			

[1] The typical values of the propagation delay and transition times are calculated from the extrapolation formulas shown (C_L in pF).

[2] t_i is the same as t_{THL} and t_{TLH}.

[3] For other R_{EXT}, C_{EXT} combinations and C_{EXT} < 0.01 μF see Fig. 4.

[4] For other R_{EXT}, C_{EXT} combinations and C_{EXT} > 0.01 μF use formula t_W = K × R_{EXT} × C_{EXT}.

where: t_W = output pulse width (s);

R_{EXT} = external timing resistor (Ω);

C_{EXT} = external timing capacitor (F);

K = 0.42 for V_{DD} = 5 V;

K = 0.32 for V_{DD} = 10 V;

K = 0.30 for V_{DD} = 15 V.

[5] T_{amb} = -40 °C to +85 °C; Δt_W is referenced to t_W at T_{amb} = 25 °C.

Table 8. Dynamic power dissipation P_D

P_D can be calculated from the formulas shown. V_{SS} = 0 V; t_r = t_f ≤ 20 ns; T_{amb} = 25 °C.

Symbol	Parameter	V _{DD}	Typical formula for P _D (μW)	where:
P _D	dynamic power dissipation	5 V	$P_D = 4000 \times f_i + \Sigma(f_o \times C_L) \times V_{DD}^2$	f _i = input frequency in MHz; f _o = output frequency in MHz; C _L = output load capacitance in pF; V _{DD} = supply voltage in V; Σ(f _o × C _L) = sum of the outputs.
		10 V	$P_D = 20000 \times f_i + \Sigma(f_o \times C_L) \times V_{DD}^2$	
		15 V	$P_D = 59000 \times f_i + \Sigma(f_o \times C_L) \times V_{DD}^2$	

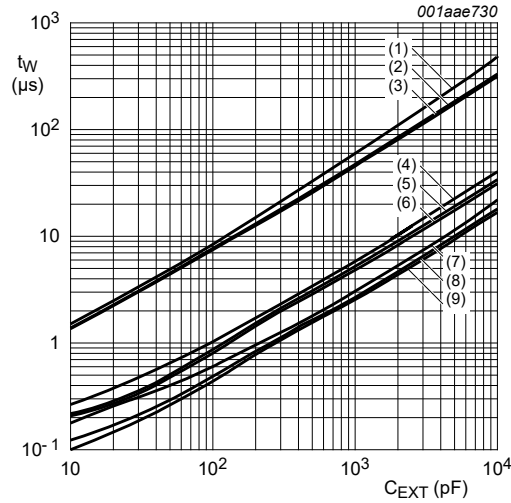

- (1) $R_{EXT} = 100\text{ k}\Omega$, $V_{DD} = 5\text{ V}$.
- (2) $R_{EXT} = 100\text{ k}\Omega$, $V_{DD} = 10\text{ V}$.
- (3) $R_{EXT} = 100\text{ k}\Omega$, $V_{DD} = 15\text{ V}$.
- (4) $R_{EXT} = 10\text{ k}\Omega$, $V_{DD} = 5\text{ V}$.
- (5) $R_{EXT} = 10\text{ k}\Omega$, $V_{DD} = 10\text{ V}$.
- (6) $R_{EXT} = 10\text{ k}\Omega$, $V_{DD} = 15\text{ V}$.
- (7) $R_{EXT} = 5\text{ k}\Omega$, $V_{DD} = 5\text{ V}$.
- (8) $R_{EXT} = 5\text{ k}\Omega$, $V_{DD} = 10\text{ V}$.
- (9) $R_{EXT} = 5\text{ k}\Omega$, $V_{DD} = 15\text{ V}$.

Fig. 4. Output pulse width (t_w) as a function of external timing capacitor (C_{EXT})

10.1. Waveforms and test circuit

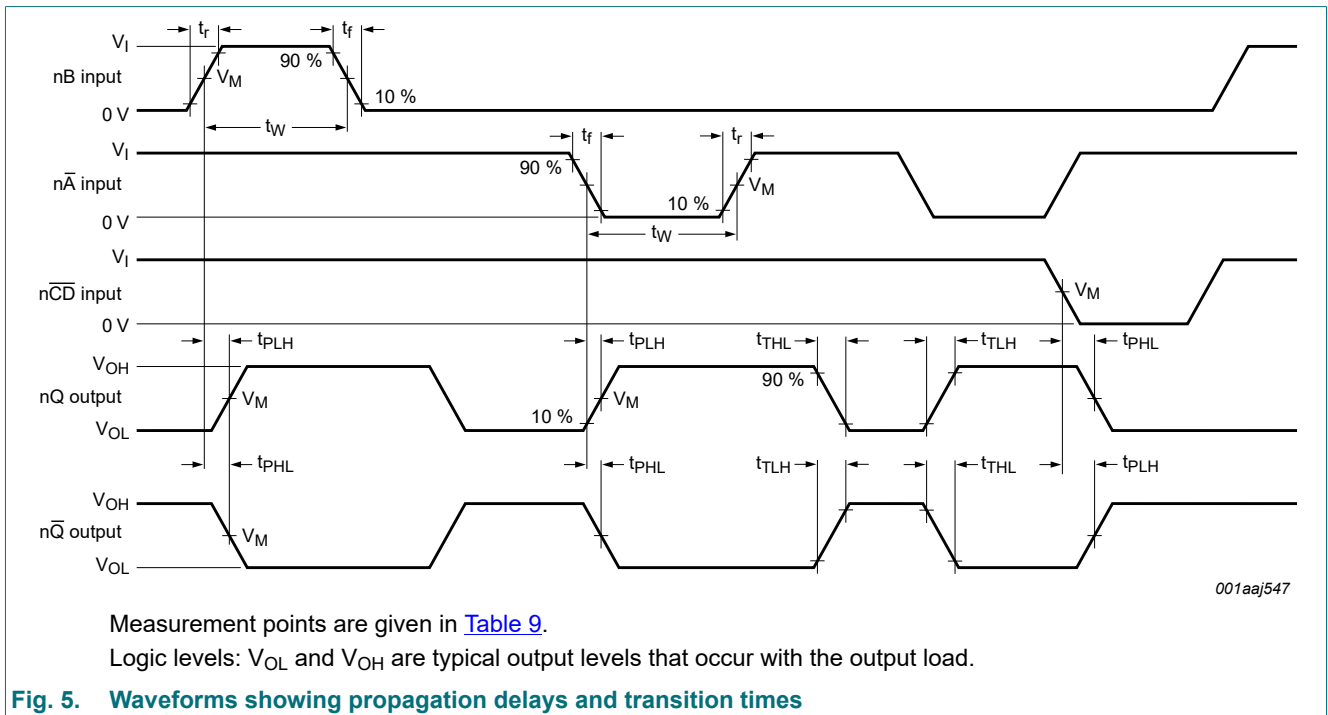
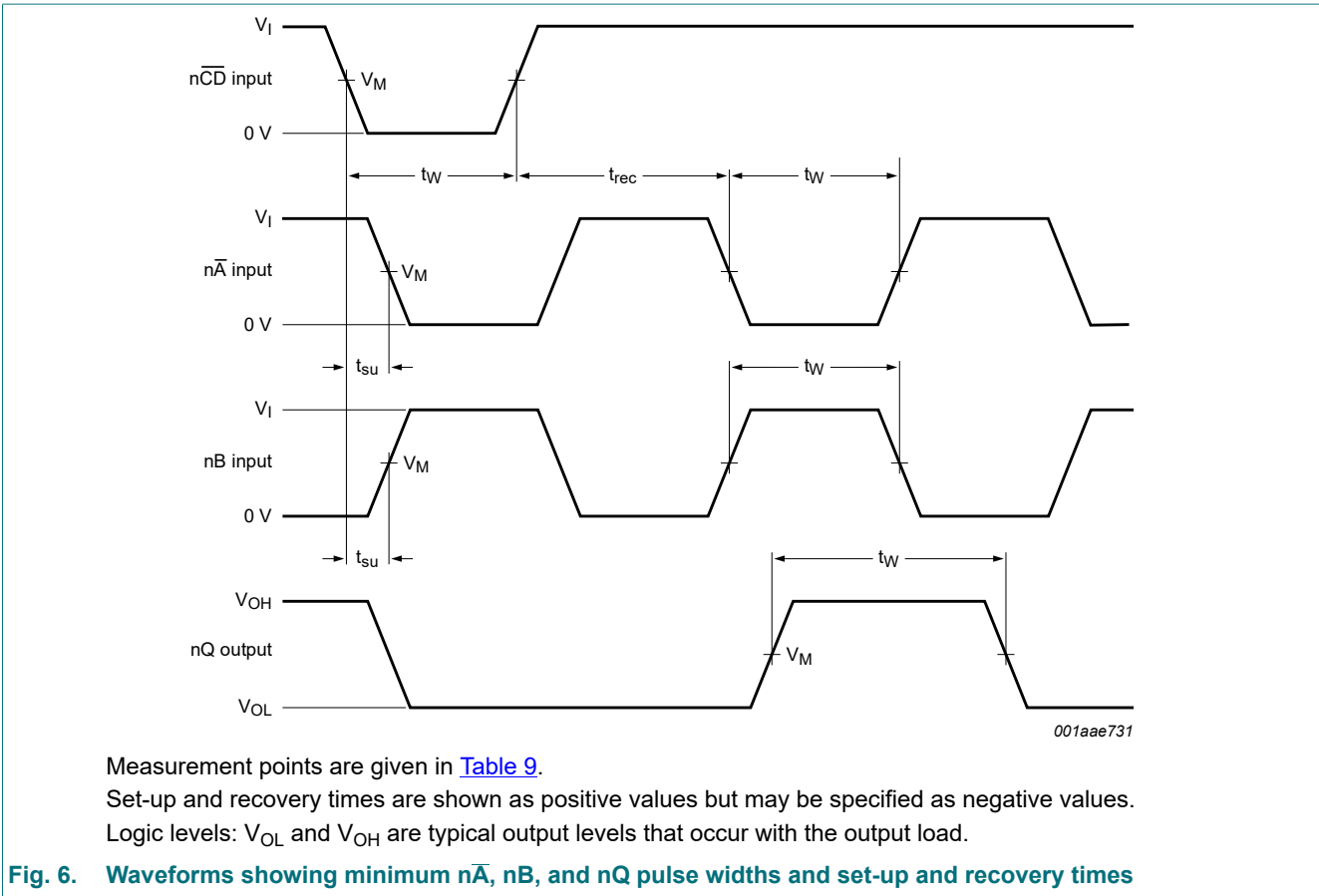

Fig. 5. Waveforms showing propagation delays and transition times



Measurement points are given in [Table 9](#).
 Set-up and recovery times are shown as positive values but may be specified as negative values.
 Logic levels: V_{OL} and V_{OH} are typical output levels that occur with the output load.

Fig. 6. Waveforms showing minimum $n\overline{A}$, nB , and nQ pulse widths and set-up and recovery times

Table 9. Measurement points

Supply voltage	Input	Output
V_{DD}	V_M	V_M
5 V to 15 V	$0.5 \times V_{DD}$	$0.5 \times V_{DD}$

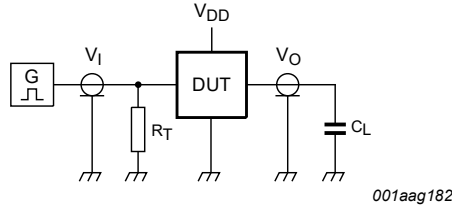

Test data is given in [Table 10](#).

Definitions for test circuit:

C_L = load capacitance including jig and probe capacitance;

R_T = termination resistance should be equal to the output impedance Z_o of the pulse generator.

Fig. 7. Test circuit for measuring switching times

Table 10. Test data

Supply voltage	Input		Load
V_{DD}	V_I	t_r, t_f	C_L
5 V to 15 V	V_{SS} or V_{DD}	≤ 20 ns	50 pF

11. Application information

An example of a HEF4528B-Q100 application is:

- Non-retriggerable monostable multivibrator

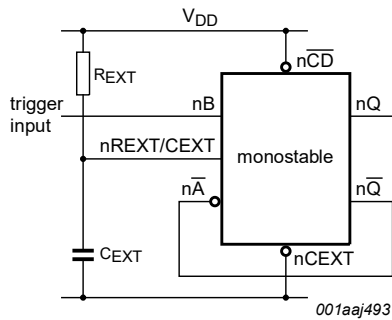

a. Rising edge triggered

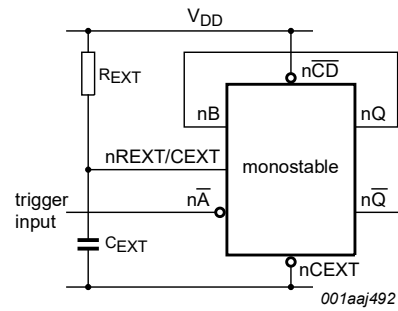

b. Falling edge triggered

Fig. 8. Non-retriggerable applications

12. Package outline

SO16: plastic small outline package; 16 leads; body width 3.9 mm

SOT109-1

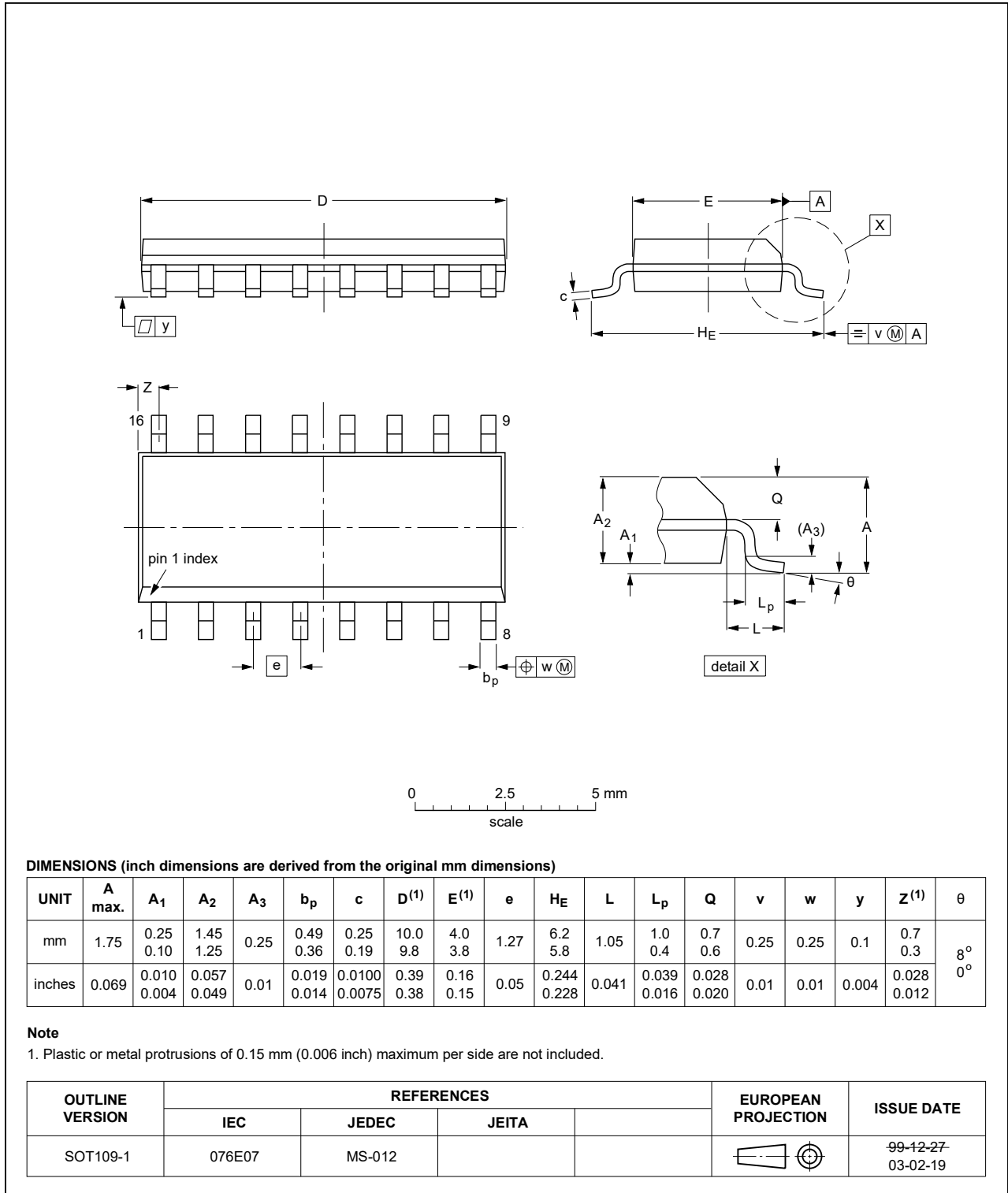

Fig. 9. Package outline SOT109-1 (SO16)

13. Abbreviations

Table 11. Abbreviations

Acronym	Description
CDM	Charged Device Model
DUT	Device Under Test
ESD	ElectroStatic Discharge
HBM	Human Body Model
MIL	Military
MM	Machine Model

14. Revision history

Table 12. Revision history

Document ID	Release date	Data sheet status	Change notice	Supersedes
HEF4528B_Q100 v.2	20220304	Product data sheet	-	HEF4528B_Q100 v.1
Modifications	<ul style="list-style-type: none"> Section 2 updated. 			
HEF4528B_Q100 v.1	20170314	Product data sheet	-	-

15. Legal information

Data sheet status

Document status [1][2]	Product status [3]	Definition
Objective [short] data sheet	Development	This document contains data from the objective specification for product development.
Preliminary [short] data sheet	Qualification	This document contains data from the preliminary specification.
Product [short] data sheet	Production	This document contains the product specification.

- [1] Please consult the most recently issued document before initiating or completing a design.
- [2] The term 'short data sheet' is explained in section "Definitions".
- [3] The product status of device(s) described in this document may have changed since this document was published and may differ in case of multiple devices. The latest product status information is available on the internet at <https://www.nexperia.com>.

Definitions

Draft — The document is a draft version only. The content is still under internal review and subject to formal approval, which may result in modifications or additions. Nexperia does not give any representations or warranties as to the accuracy or completeness of information included herein and shall have no liability for the consequences of use of such information.

Short data sheet — A short data sheet is an extract from a full data sheet with the same product type number(s) and title. A short data sheet is intended for quick reference only and should not be relied upon to contain detailed and full information. For detailed and full information see the relevant full data sheet, which is available on request via the local Nexperia sales office. In case of any inconsistency or conflict with the short data sheet, the full data sheet shall prevail.

Product specification — The information and data provided in a Product data sheet shall define the specification of the product as agreed between Nexperia and its customer, unless Nexperia and customer have explicitly agreed otherwise in writing. In no event however, shall an agreement be valid in which the Nexperia product is deemed to offer functions and qualities beyond those described in the Product data sheet.

Disclaimers

Limited warranty and liability — Information in this document is believed to be accurate and reliable. However, Nexperia does not give any representations or warranties, expressed or implied, as to the accuracy or completeness of such information and shall have no liability for the consequences of use of such information. Nexperia takes no responsibility for the content in this document if provided by an information source outside of Nexperia.

In no event shall Nexperia be liable for any indirect, incidental, punitive, special or consequential damages (including - without limitation - lost profits, lost savings, business interruption, costs related to the removal or replacement of any products or rework charges) whether or not such damages are based on tort (including negligence), warranty, breach of contract or any other legal theory.

Notwithstanding any damages that customer might incur for any reason whatsoever, Nexperia's aggregate and cumulative liability towards customer for the products described herein shall be limited in accordance with the Terms and conditions of commercial sale of Nexperia.

Right to make changes — Nexperia reserves the right to make changes to information published in this document, including without limitation specifications and product descriptions, at any time and without notice. This document supersedes and replaces all information supplied prior to the publication hereof.

Suitability for use in automotive applications — This Nexperia product has been qualified for use in automotive applications. Unless otherwise agreed in writing, the product is not designed, authorized or warranted to be suitable for use in life support, life-critical or safety-critical systems or

equipment, nor in applications where failure or malfunction of an Nexperia product can reasonably be expected to result in personal injury, death or severe property or environmental damage. Nexperia and its suppliers accept no liability for inclusion and/or use of Nexperia products in such equipment or applications and therefore such inclusion and/or use is at the customer's own risk.

Quick reference data — The Quick reference data is an extract of the product data given in the Limiting values and Characteristics sections of this document, and as such is not complete, exhaustive or legally binding.

Applications — Applications that are described herein for any of these products are for illustrative purposes only. Nexperia makes no representation or warranty that such applications will be suitable for the specified use without further testing or modification.

Customers are responsible for the design and operation of their applications and products using Nexperia products, and Nexperia accepts no liability for any assistance with applications or customer product design. It is customer's sole responsibility to determine whether the Nexperia product is suitable and fit for the customer's applications and products planned, as well as for the planned application and use of customer's third party customer(s). Customers should provide appropriate design and operating safeguards to minimize the risks associated with their applications and products.

Nexperia does not accept any liability related to any default, damage, costs or problem which is based on any weakness or default in the customer's applications or products, or the application or use by customer's third party customer(s). Customer is responsible for doing all necessary testing for the customer's applications and products using Nexperia products in order to avoid a default of the applications and the products or of the application or use by customer's third party customer(s). Nexperia does not accept any liability in this respect.

Limiting values — Stress above one or more limiting values (as defined in the Absolute Maximum Ratings System of IEC 60134) will cause permanent damage to the device. Limiting values are stress ratings only and (proper) operation of the device at these or any other conditions above those given in the Recommended operating conditions section (if present) or the Characteristics sections of this document is not warranted. Constant or repeated exposure to limiting values will permanently and irreversibly affect the quality and reliability of the device.

Terms and conditions of commercial sale — Nexperia products are sold subject to the general terms and conditions of commercial sale, as published at <http://www.nexperia.com/profile/terms>, unless otherwise agreed in a valid written individual agreement. In case an individual agreement is concluded only the terms and conditions of the respective agreement shall apply. Nexperia hereby expressly objects to applying the customer's general terms and conditions with regard to the purchase of Nexperia products by customer.

No offer to sell or license — Nothing in this document may be interpreted or construed as an offer to sell products that is open for acceptance or the grant, conveyance or implication of any license under any copyrights, patents or other industrial or intellectual property rights.

Export control — This document as well as the item(s) described herein may be subject to export control regulations. Export might require a prior authorization from competent authorities.

Translations — A non-English (translated) version of a document is for reference only. The English version shall prevail in case of any discrepancy between the translated and English versions.

Trademarks

Notice: All referenced brands, product names, service names and trademarks are the property of their respective owners.

Contents

1. General description	1
2. Features and benefits	1
3. Ordering information	1
4. Functional diagram	2
5. Pinning information	2
5.1. Pinning.....	2
5.2. Pin description.....	3
6. Functional description	3
7. Limiting values	3
8. Recommended operating conditions	4
9. Static characteristics	4
10. Dynamic characteristics	5
10.1. Waveforms and test circuit.....	7
11. Application information	9
12. Package outline	10
13. Abbreviations	11
14. Revision history	11
15. Legal information	12

© Nexperia B.V. 2022. All rights reserved

For more information, please visit: <http://www.nexperia.com>

For sales office addresses, please send an email to: salesaddresses@nexperia.com

Date of release: 4 March 2022
