

HEF4794B-Q100

8-stage shift-and-store register LED driver

Rev. 2 — 7 November 2018

Product data sheet

1. General description

The HEF4794B-Q100 is an 8-stage serial shift register. It has a storage latch associated with each stage for strobing data from the serial input (D) to the parallel LED driver outputs (QP0 to QP7). Data is shifted on the positive-going clock (CP) transitions. The data in each shift register stage is transferred to the storage register when the strobe input (STR) is HIGH. Data in the storage register appears at the outputs whenever the output enable input (OE) signal is HIGH.

Two serial outputs (QS1 and QS2) are available for cascading a number of HEF4794B-Q100 devices. Serial data is available at QS1 on positive-going clock edges to allow high-speed operation in cascaded systems with a fast clock rise time. The same serial data is available at QS2 on the next negative going clock edge. This is used for cascading HEF4794B-Q100 devices when the clock has a slow rise time.

It operates over a recommended V_{DD} power supply range of 3 V to 15 V referenced to V_{SS} (usually ground). Unused inputs must be connected to V_{DD} , V_{SS} , or another input.

This product has been qualified to the Automotive Electronics Council (AEC) standard Q100 (Grade 1) and is suitable for use in automotive applications.

2. Features and benefits

- Automotive product qualification in accordance with AEC-Q100 (Grade 1)
 - Specified from -40 °C to +85 °C and from -40 °C to +125 °C
- Fully static operation
- 5 V, 10 V, and 15 V parametric ratings
- Standardized symmetrical output characteristics
- ESD protection:
 - MIL-STD-883, method 3015 exceeds 2000 V
 - HBM JESD22-A114F exceeds 2000 V
 - MM JESD22-A115-A exceeds 200 V (C = 200 pF; R = 0 Ω)
- Complies with JEDEC standard JESD 13-B

3. Ordering information

Table 1. Ordering information

All types operate from -40 °C to +125 °C.

| Type number | Package | | |
|----------------|---------|--|----------|
| | Name | Description | Version |
| HEF4794BT-Q100 | SO16 | plastic small outline package; 16 leads; body width 3.9 mm | SOT109-1 |

4. Functional diagram

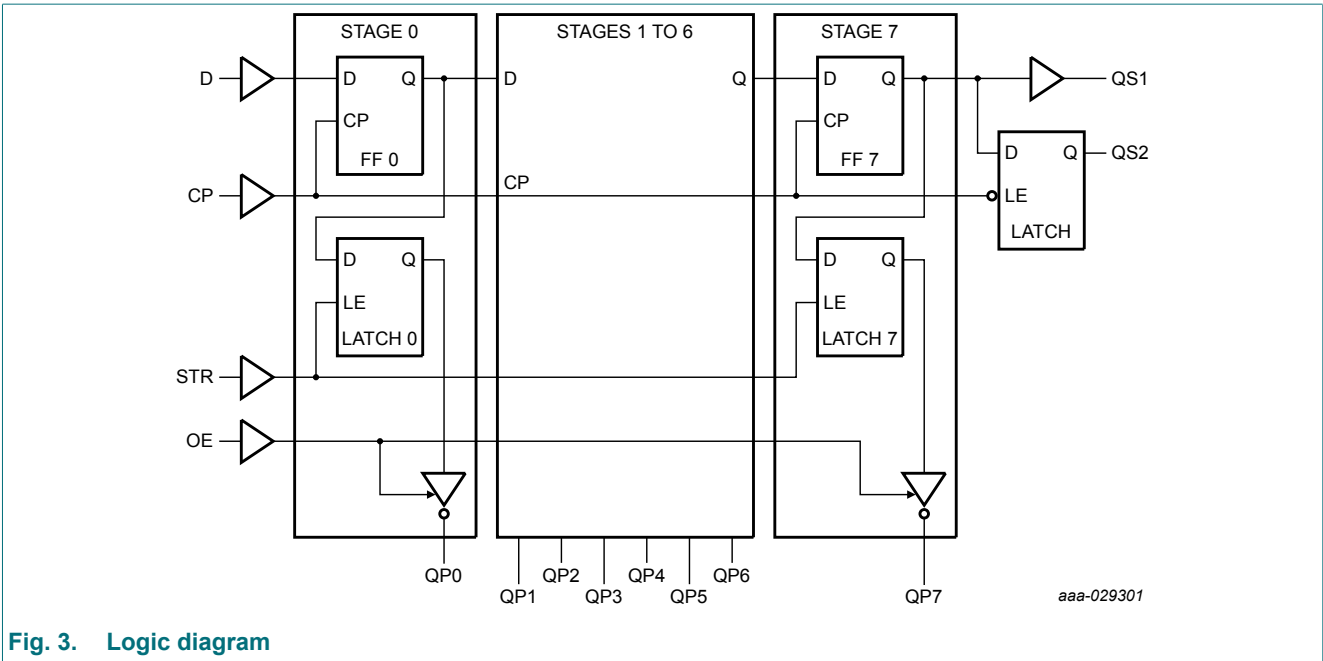
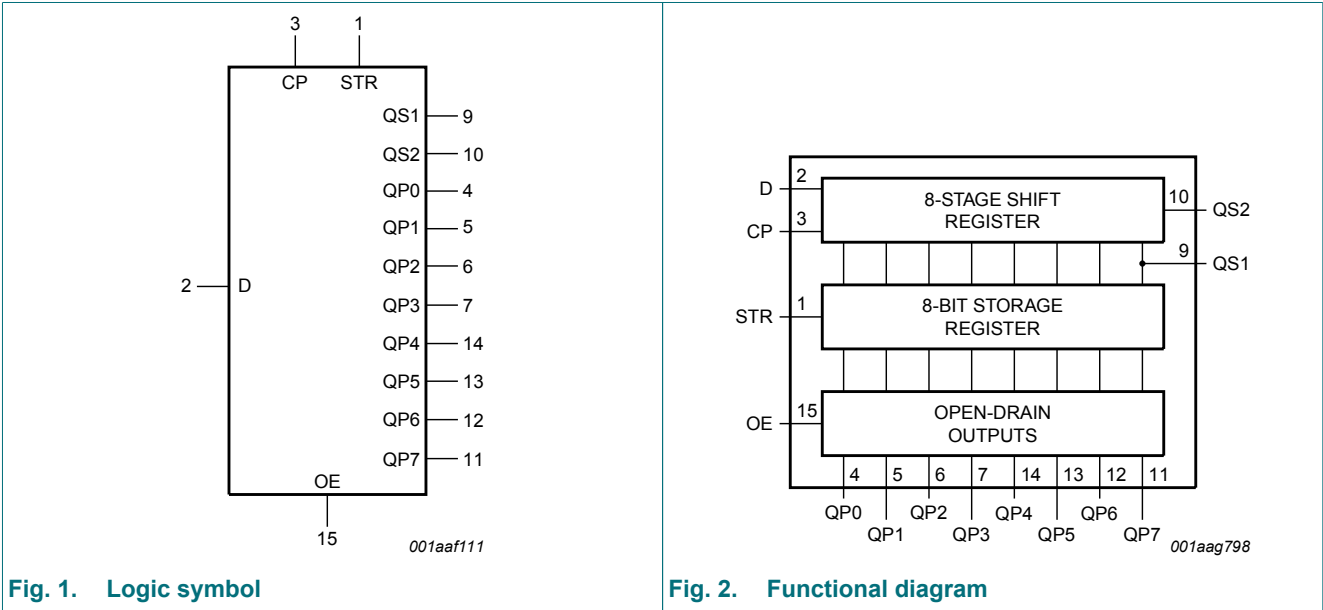

5. Pinning information

5.1. Pinning

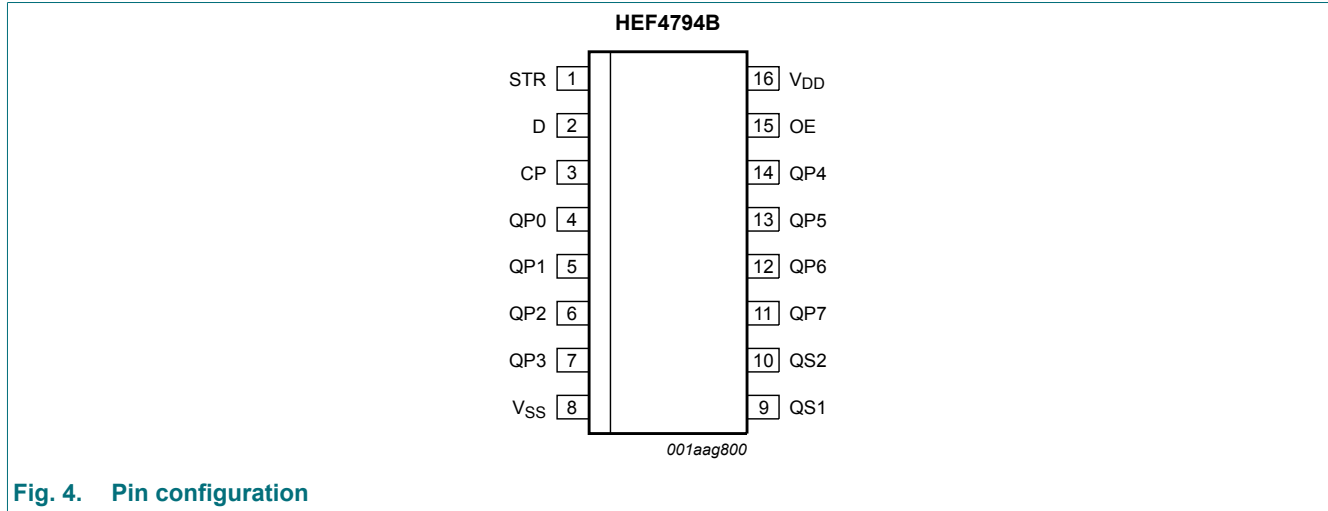

Fig. 4. Pin configuration

5.2. Pin description

Table 2. Pin description

| Symbol | Pin | Description |
|-----------------|----------------------------|------------------------------|
| D | 2 | serial input |
| QP0 to QP7 | 4, 5, 6, 7, 14, 13, 12, 11 | parallel output (open-drain) |
| QS1 | 9 | serial output |
| QS2 | 10 | serial output |
| CP | 3 | clock input |
| STR | 1 | strobe input |
| OE | 15 | output enable input |
| V _{DD} | 16 | supply voltage |
| V _{SS} | 8 | ground (0 V) |

6. Functional description

Table 3. Function table

H = HIGH voltage level; L = LOW voltage level; X = don't care; Z = high-impedance OFF-state;
 ↑ = LOW-to-HIGH clock transition; ↓ = HIGH-to-LOW clock transition.

| Input | | | | Parallel output | | Serial output | |
|-------|----|-----|---|-----------------|-----------|---------------|-----------|
| CP | OE | STR | D | QP0 | QPn | QS1[1] | QS2[2] |
| ↑ | L | X | X | Z | Z | Q6S | no change |
| ↓ | L | X | X | Z | Z | n.c. | Q7S |
| ↑ | H | L | X | no change | no change | Q6S | no change |
| ↑ | H | H | L | Z | QPn - 1 | Q6S | no change |
| ↑ | H | H | H | L | QPn - 1 | Q6S | no change |
| ↓ | H | H | H | no change | no change | no change | Q7S |

- [1] Q6S = the data in register stage 6 before the LOW to HIGH clock transition.
- [2] Q7S = the data in register stage 7 before the HIGH to LOW clock transition.

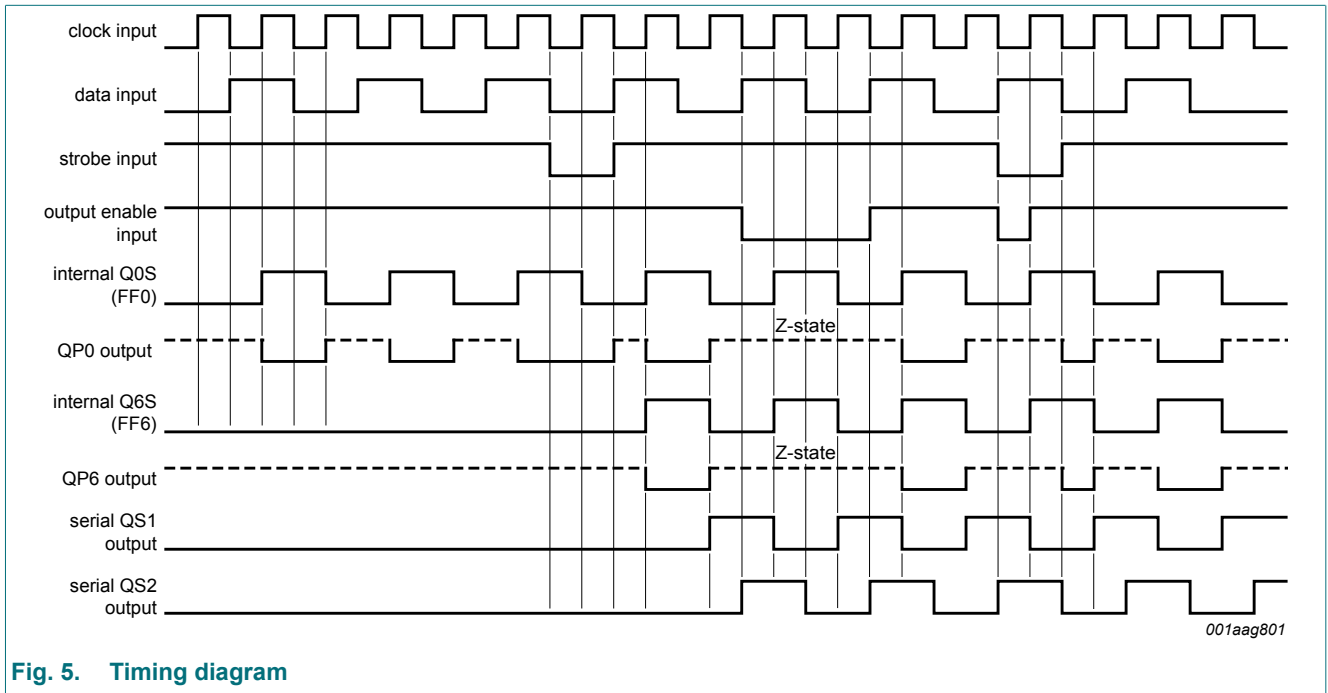

Fig. 5. Timing diagram

7. Limiting values

Table 4. Limiting values

In accordance with the Absolute Maximum Rating System (IEC 60134).

| Symbol | Parameter | Conditions | Min | Max | Unit |
|-----------|-------------------------|--|------|----------------|------|
| V_{DD} | supply voltage | | -0.5 | +18 | V |
| I_{IK} | input clamping current | $V_I < -0.5\text{ V}$ or $V_I > V_{DD} + 0.5\text{ V}$ | - | ± 10 | mA |
| V_I | input voltage | | -0.5 | $V_{DD} + 0.5$ | V |
| I_{OK} | output clamping current | QSn outputs; $V_O < -0.5\text{ V}$ or $V_O > V_{DD} + 0.5\text{ V}$ | - | ± 10 | mA |
| | | QPn outputs; $V_O < -0.5\text{ V}$ | - | 40 | mA |
| I_I | input leakage current | | - | ± 10 | mA |
| I_O | output current | QSn outputs | - | ± 10 | mA |
| | | QPn outputs | - | 40 | mA |
| T_{stg} | storage temperature | | -65 | +150 | °C |
| T_{amb} | ambient temperature | | -40 | +125 | °C |
| P_{tot} | total power dissipation | $T_{amb} = -40\text{ °C}$ to $+125\text{ °C}$ | | | |
| | | SO16 package [1] | - | 500 | mW |
| P | power dissipation | per output | - | 100 | mW |

[1] For SO16 package: P_{tot} derates linearly with 8 mW/K above 70 °C.

8. Recommended operating conditions

Table 5. Recommended operating conditions

| Symbol | Parameter | Conditions | Min | Max | Unit |
|---------------------|-------------------------------------|------------------------|-----|----------|-----------------|
| V_{DD} | supply voltage | | 3 | 15 | V |
| V_I | input voltage | | 0 | V_{DD} | V |
| T_{amb} | ambient temperature | in free air | -40 | +125 | °C |
| $\Delta t/\Delta V$ | input transition rise and fall rate | $V_{DD} = 5\text{ V}$ | - | 3.75 | $\mu\text{s/V}$ |
| | | $V_{DD} = 10\text{ V}$ | - | 0.5 | $\mu\text{s/V}$ |
| | | $V_{DD} = 15\text{ V}$ | - | 0.08 | $\mu\text{s/V}$ |

9. Static characteristics

Table 6. Static characteristics

$V_{SS} = 0\text{ V}$; $V_I = V_{SS}$ or V_{DD} ; unless otherwise specified.

| Symbol | Parameter | Conditions | V _{DD} | T _{amb} = -40 °C | | T _{amb} = 25 °C | | T _{amb} = 85 °C | | T _{amb} = 125 °C | | Unit |
|-----------------|---------------------------|--|-----------------|---------------------------|-------|--------------------------|------|--------------------------|-------|---------------------------|-------|------|
| | | | | Min | Max | Min | Max | Min | Max | Min | Max | |
| V _{IH} | HIGH-level input voltage | I _o < 1 μA | 5 V | 3.5 | - | 3.5 | - | 3.5 | - | 3.5 | - | V |
| | | | 10 V | 7.0 | - | 7.0 | - | 7.0 | - | 7.0 | - | V |
| | | | 15 V | 11.0 | - | 11.0 | - | 11.0 | - | 11.0 | - | V |
| V _{IL} | LOW-level input voltage | I _o < 1 μA | 5 V | - | 1.5 | - | 1.5 | - | 1.5 | - | 1.5 | V |
| | | | 10 V | - | 3.0 | - | 3.0 | - | 3.0 | - | 3.0 | V |
| | | | 15 V | - | 4.0 | - | 4.0 | - | 4.0 | - | 4.0 | V |
| V _{OH} | HIGH-level output voltage | QSn outputs; I _o < 1 μA | 5 V | 4.95 | - | 4.95 | - | 4.95 | - | 4.95 | - | V |
| | | | 10 V | 9.95 | - | 9.95 | - | 9.95 | - | 9.95 | - | V |
| | | | 15 V | 14.95 | - | 14.95 | - | 14.95 | - | 14.95 | - | V |
| V _{OL} | LOW-level output voltage | QSn outputs; I _o < 1 μA | 5 V | - | 0.05 | - | 0.05 | - | 0.05 | - | 0.05 | V |
| | | | 10 V | - | 0.05 | - | 0.05 | - | 0.05 | - | 0.05 | V |
| | | | 15 V | - | 0.05 | - | 0.05 | - | 0.05 | - | 0.05 | V |
| | | QPn outputs; I _o < 20 mA | 5 V | - | 0.75 | - | 0.75 | - | 1.5 | - | 1.5 | V |
| | | | 10 V | - | 0.75 | - | 0.75 | - | 1.5 | - | 1.5 | V |
| | | | 15 V | - | 0.75 | - | 0.75 | - | 1.5 | - | 1.5 | V |
| I _{OH} | HIGH-level output current | QSn outputs | | | | | | | | | | |
| | | V _O = 2.5 V | 5 V | - | -1.7 | - | -1.4 | - | -1.1 | - | -1.1 | mA |
| | | V _O = 4.6 V | 5 V | - | -0.64 | - | -0.5 | - | -0.36 | - | -0.36 | mA |
| | | V _O = 9.5 V | 10 V | - | -1.6 | - | -1.3 | - | -0.9 | - | -0.9 | mA |
| | | V _O = 13.5 V | 15 V | - | -4.2 | - | -3.4 | - | -2.4 | - | -2.4 | mA |
| I _{OL} | LOW-level output current | QSn outputs | | | | | | | | | | |
| | | V _O = 0.4 V | 5 V | 0.64 | - | 0.5 | - | 0.36 | - | 0.36 | - | mA |
| | | V _O = 0.5 V | 10 V | 1.6 | - | 1.3 | - | 0.9 | - | 0.9 | - | mA |
| | | V _O = 1.5 V | 15 V | 4.2 | - | 3.4 | - | 2.4 | - | 2.4 | - | mA |
| I _I | input leakage current | | 15 V | - | ±0.1 | - | ±0.1 | - | ±1.0 | - | ±1.0 | μA |
| I _{OZ} | OFF-state output current | QPn output is HIGH; V _O = 15 V | 5 V | - | 2 | - | 2 | - | 15 | - | 15 | μA |
| | | | 10 V | - | 2 | - | 2 | - | 15 | - | 15 | μA |
| | | | 15 V | - | 2 | - | 2 | - | 15 | - | 15 | μA |
| I _{DD} | supply current | I _O = 0 A | 5 V | - | 5 | - | 5 | - | 150 | - | 150 | μA |
| | | | 10 V | - | 10 | - | 10 | - | 300 | - | 300 | μA |
| | | | 15 V | - | 20 | - | 20 | - | 600 | - | 600 | μA |
| C _I | input capacitance | | - | - | - | - | - | 7.5 | - | - | - | pF |

10. Dynamic characteristics

Table 7. Dynamic characteristics

$V_{SS} = 0\text{ V}$; $T_{amb} = 25\text{ °C}$ unless otherwise specified. For test circuit, see Fig. 10.

| Symbol | Parameter | Conditions | V _{DD} | Extrapolation formula | Min | Typ | Max | Unit |
|------------------|------------------------------------|--------------------------------|-----------------|-------------------------------------|-----|-----|-----|------|
| t _{PHL} | HIGH to LOW propagation delay | CP to QS1; see Fig. 6 | 5 V [1] | 132 ns + (0.55 ns/pF)C _L | - | 160 | 320 | ns |
| | | | 10 V | 53 ns + (0.23 ns/pF)C _L | - | 65 | 130 | ns |
| | | | 15 V | 37 ns + (0.16 ns/pF)C _L | - | 45 | 90 | ns |
| | | CP to QS2; see Fig. 6 | 5 V | 92 ns + (0.55 ns/pF)C _L | - | 120 | 240 | ns |
| | | | 10 V | 39 ns + (0.23 ns/pF)C _L | - | 50 | 100 | ns |
| | | | 15 V | 32 ns + (0.16 ns/pF)C _L | - | 40 | 80 | ns |
| t _{PLH} | LOW to HIGH propagation delay | CP to QS1; see Fig. 6 | 5 V [1] | 102 ns + (0.55 ns/pF)C _L | - | 130 | 260 | ns |
| | | | 10 V | 44 ns + (0.23 ns/pF)C _L | - | 55 | 110 | ns |
| | | | 15 V | 32 ns + (0.16 ns/pF)C _L | - | 40 | 80 | ns |
| | | CP to QS2; see Fig. 6 | 5 V | 102 ns + (0.55 ns/pF)C _L | - | 130 | 260 | ns |
| | | | 10 V | 49 ns + (0.23 ns/pF)C _L | - | 60 | 120 | ns |
| | | | 15 V | 37 ns + (0.16 ns/pF)C _L | - | 45 | 90 | ns |
| t _{PZL} | OFF-state to LOW propagation delay | CP to QPn; see Fig. 6 | 5 V | | - | 240 | 480 | ns |
| | | | 10 V | | - | 80 | 160 | ns |
| | | | 15 V | | - | 55 | 110 | ns |
| | | STR to QPn; see Fig. 7 | 5 V | | - | 140 | 280 | ns |
| | | | 10 V | | - | 70 | 140 | ns |
| | | | 15 V | | - | 55 | 110 | ns |
| t _{PLZ} | LOW to OFF-state propagation delay | CP to QPn; see Fig. 6 | 5 V | | - | 170 | 340 | ns |
| | | | 10 V | | - | 75 | 150 | ns |
| | | | 15 V | | - | 60 | 120 | ns |
| | | STR to QPn; see Fig. 7 | 5 V | | - | 100 | 200 | ns |
| | | | 10 V | | - | 40 | 100 | ns |
| | | | 15 V | | - | 35 | 70 | ns |
| t _{en} | enable time | OE to QPn; see Fig. 8 | 5 V [2] | | - | 100 | 200 | ns |
| | | | 10 V | | - | 55 | 110 | ns |
| | | | 15 V | | - | 50 | 100 | ns |
| t _{dis} | disable time | OE to QPn; see Fig. 8 | 5 V [2] | | - | 80 | 160 | ns |
| | | | 10 V | | - | 40 | 80 | ns |
| | | | 15 V | | - | 30 | 60 | ns |
| t _t | transition time | QS1, QS2; see Fig. 6 | 5 V [1][3] | 35 ns + (1.00 ns/pF)C _L | - | 85 | 170 | ns |
| | | | 10 V | 19 ns + (0.42 ns/pF)C _L | - | 40 | 80 | ns |
| | | | 15 V | 16 ns + (0.28 ns/pF)C _L | - | 30 | 60 | ns |
| t _w | pulse width | CP LOW and HIGH; see Fig. 6 | 5 V | | 60 | 30 | - | ns |
| | | | 10 V | | 30 | 15 | - | ns |
| | | | 15 V | | 24 | 12 | - | ns |
| | | STR HIGH; see Fig. 7 | 5 V | | 80 | 40 | - | ns |
| | | | 10 V | | 60 | 30 | - | ns |
| | | | 15 V | | 24 | 12 | - | ns |

Table 9. Measurement points

| Supply | Input | Output | | |
|-------------|-------------|-------------|----------|----------|
| V_{DD} | V_M | V_M | V_X | V_Y |
| 5 V to 15 V | $0.5V_{DD}$ | $0.5V_{DD}$ | $0.1V_O$ | $0.9V_O$ |

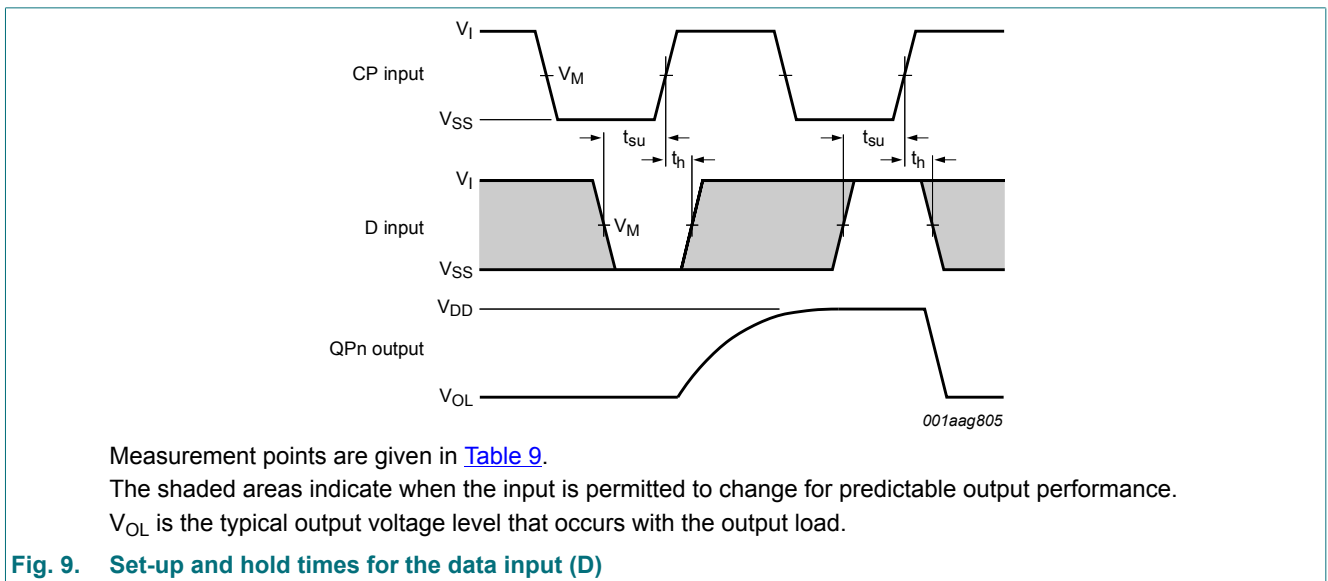
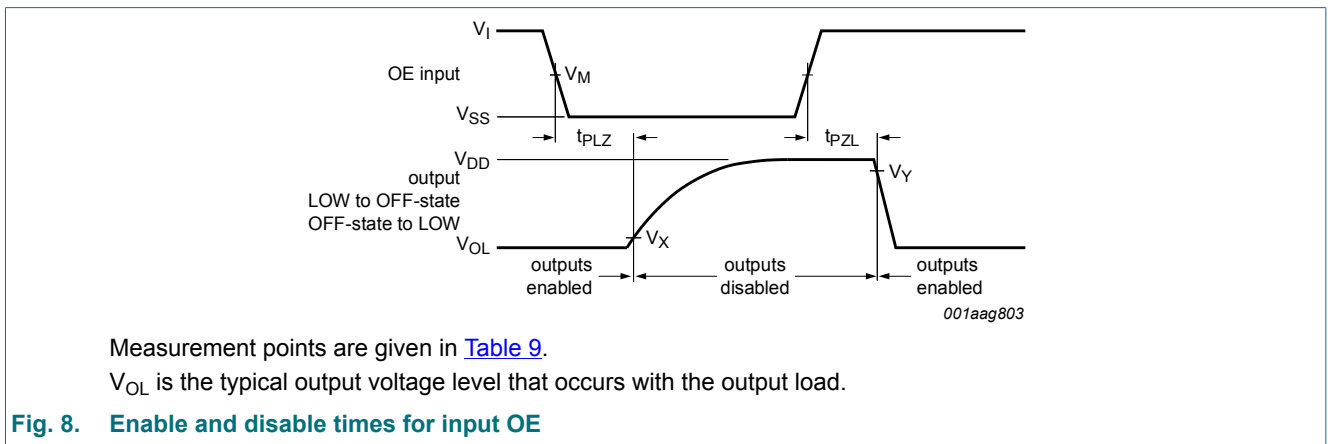
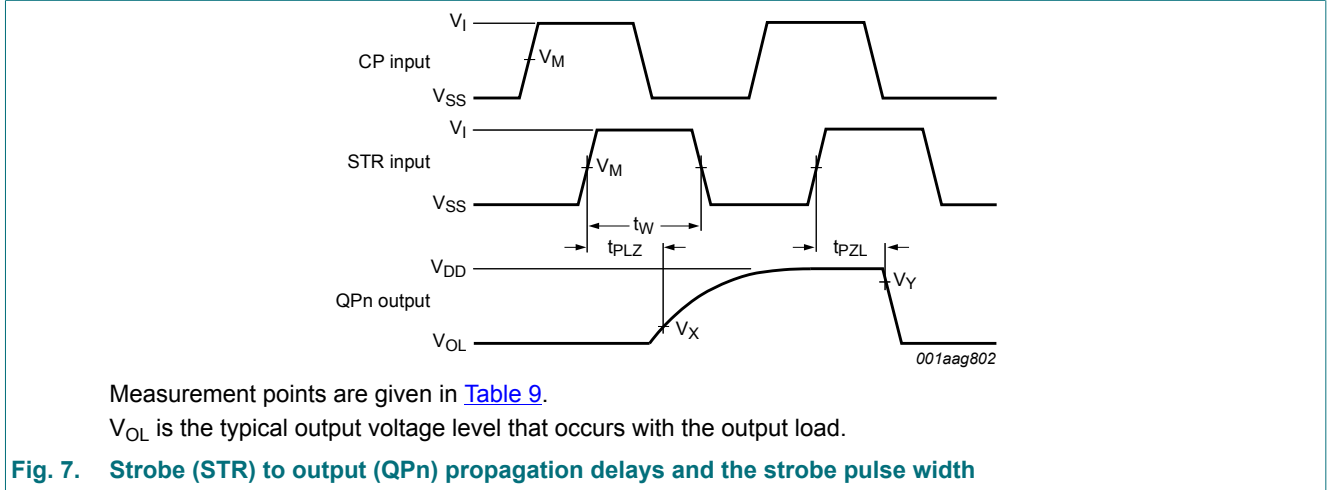

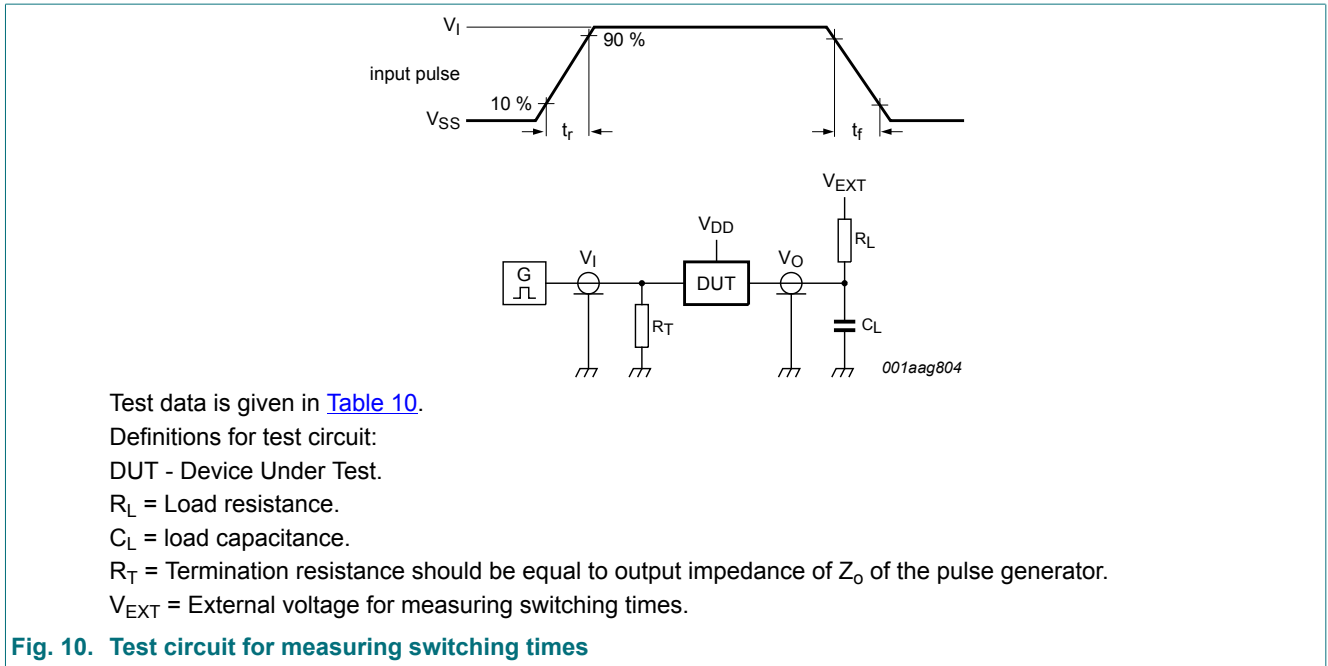

Fig. 10. Test circuit for measuring switching times

Table 10. Test data

| Supply | Input | V_{EXT} | Load |
|-------------|----------|--------------------|--------------|
| V_{DD} | V_I | t_{PLZ}, t_{PZL} | C_L |
| 5 V to 15 V | V_{DD} | t_r, t_f | R_L |
| | | ≤ 20 ns | 50 pF |
| | | V_{DD} | 1 k Ω |
| | | t_{PLH}, t_{PHL} | open |

11. Application information

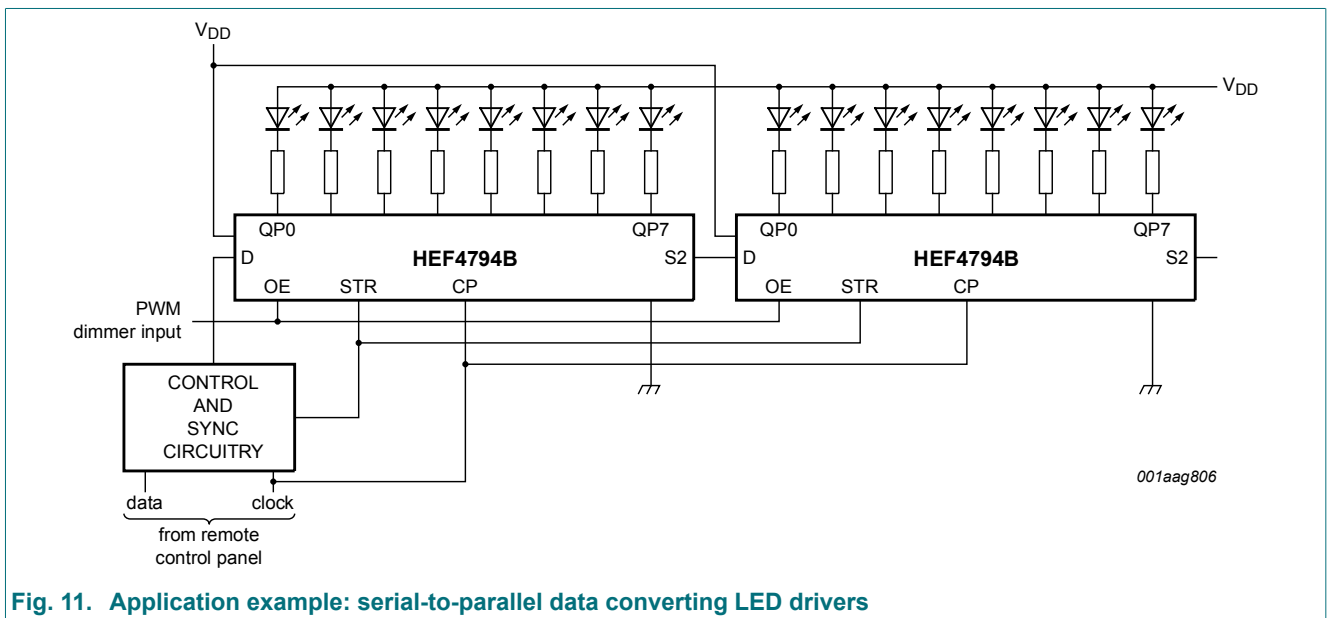
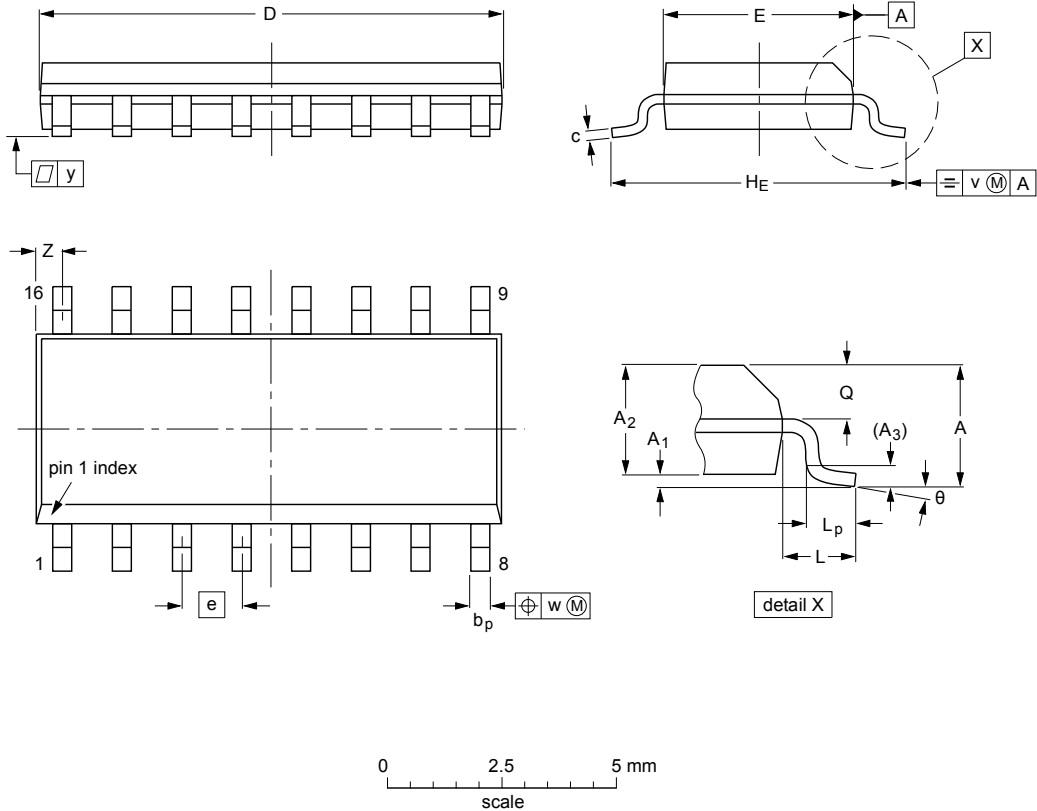

Fig. 11. Application example: serial-to-parallel data converting LED drivers

12. Package outline

SO16: plastic small outline package; 16 leads; body width 3.9 mm

SOT109-1



DIMENSIONS (inch dimensions are derived from the original mm dimensions)

| UNIT | A max. | A ₁ | A ₂ | A ₃ | b _p | c | D ⁽¹⁾ | E ⁽¹⁾ | e | H _E | L | L _p | Q | v | w | y | Z ⁽¹⁾ | θ |
|--------|--------|----------------|----------------|----------------|----------------|------------------|------------------|------------------|------|----------------|-------|----------------|----------------|------|------|-------|------------------|----------|
| mm | 1.75 | 0.25 0.10 | 1.45 1.25 | 0.25 | 0.49 0.36 | 0.25 0.19 | 10.0 9.8 | 4.0 3.8 | 1.27 | 6.2 5.8 | 1.05 | 1.0 0.4 | 0.7 0.6 | 0.25 | 0.25 | 0.1 | 0.7 0.3 | 8° 0° |
| inches | 0.069 | 0.010 0.004 | 0.057 0.049 | 0.01 | 0.019 0.014 | 0.0100 0.0075 | 0.39 0.38 | 0.16 0.15 | 0.05 | 0.244 0.228 | 0.041 | 0.039 0.016 | 0.028 0.020 | 0.01 | 0.01 | 0.004 | 0.028 0.012 | |

Note

1. Plastic or metal protrusions of 0.15 mm (0.006 inch) maximum per side are not included.

| OUTLINE VERSION | REFERENCES | | | | EUROPEAN PROJECTION | ISSUE DATE |
|-----------------|------------|--------|-------|--|---------------------|----------------------|
| | IEC | JEDEC | JEITA | | | |
| SOT109-1 | 076E07 | MS-012 | | | | 99-12-27 03-02-19 |

Fig. 12. Package outline SOT109-1 (SO16)

13. Revision history

Table 11. Revision history

| Document ID | Release date | Data sheet status | Change notice | Supersedes |
|-------------------|--|--------------------|---------------|-------------------|
| HEF4794B_Q100 v.2 | 20181107 | Product data sheet | - | HEF4794B_Q100 v.1 |
| Modifications: | <ul style="list-style-type: none">• The format of this data sheet has been redesigned to comply with the identity guidelines of Nexperia.• Legal texts have been adapted to the new company name where appropriate.• Fig. 5 corrected. | | | |
| HEF4794B_Q100 v.1 | 20120807 | Product data sheet | - | - |

14. Legal information

Data sheet status

| Document status [1][2] | Product status [3] | Definition |
|--------------------------------|--------------------|---|
| Objective [short] data sheet | Development | This document contains data from the objective specification for product development. |
| Preliminary [short] data sheet | Qualification | This document contains data from the preliminary specification. |
| Product [short] data sheet | Production | This document contains the product specification. |

- [1] Please consult the most recently issued document before initiating or completing a design.
- [2] The term 'short data sheet' is explained in section "Definitions".
- [3] The product status of device(s) described in this document may have changed since this document was published and may differ in case of multiple devices. The latest product status information is available on the internet at <https://www.nexperia.com>.

Definitions

Draft — The document is a draft version only. The content is still under internal review and subject to formal approval, which may result in modifications or additions. Nexperia does not give any representations or warranties as to the accuracy or completeness of information included herein and shall have no liability for the consequences of use of such information.

Short data sheet — A short data sheet is an extract from a full data sheet with the same product type number(s) and title. A short data sheet is intended for quick reference only and should not be relied upon to contain detailed and full information. For detailed and full information see the relevant full data sheet, which is available on request via the local Nexperia sales office. In case of any inconsistency or conflict with the short data sheet, the full data sheet shall prevail.

Product specification — The information and data provided in a Product data sheet shall define the specification of the product as agreed between Nexperia and its customer, unless Nexperia and customer have explicitly agreed otherwise in writing. In no event however, shall an agreement be valid in which the Nexperia product is deemed to offer functions and qualities beyond those described in the Product data sheet.

Disclaimers

Limited warranty and liability — Information in this document is believed to be accurate and reliable. However, Nexperia does not give any representations or warranties, expressed or implied, as to the accuracy or completeness of such information and shall have no liability for the consequences of use of such information. Nexperia takes no responsibility for the content in this document if provided by an information source outside of Nexperia.

In no event shall Nexperia be liable for any indirect, incidental, punitive, special or consequential damages (including - without limitation - lost profits, lost savings, business interruption, costs related to the removal or replacement of any products or rework charges) whether or not such damages are based on tort (including negligence), warranty, breach of contract or any other legal theory.

Notwithstanding any damages that customer might incur for any reason whatsoever, Nexperia's aggregate and cumulative liability towards customer for the products described herein shall be limited in accordance with the Terms and conditions of commercial sale of Nexperia.

Right to make changes — Nexperia reserves the right to make changes to information published in this document, including without limitation specifications and product descriptions, at any time and without notice. This document supersedes and replaces all information supplied prior to the publication hereof.

Suitability for use in automotive applications — This Nexperia product has been qualified for use in automotive applications. Unless otherwise agreed in writing, the product is not designed, authorized or warranted to be suitable for use in life support, life-critical or safety-critical systems or

equipment, nor in applications where failure or malfunction of an Nexperia product can reasonably be expected to result in personal injury, death or severe property or environmental damage. Nexperia and its suppliers accept no liability for inclusion and/or use of Nexperia products in such equipment or applications and therefore such inclusion and/or use is at the customer's own risk.

Quick reference data — The Quick reference data is an extract of the product data given in the Limiting values and Characteristics sections of this document, and as such is not complete, exhaustive or legally binding.

Applications — Applications that are described herein for any of these products are for illustrative purposes only. Nexperia makes no representation or warranty that such applications will be suitable for the specified use without further testing or modification.

Customers are responsible for the design and operation of their applications and products using Nexperia products, and Nexperia accepts no liability for any assistance with applications or customer product design. It is customer's sole responsibility to determine whether the Nexperia product is suitable and fit for the customer's applications and products planned, as well as for the planned application and use of customer's third party customer(s). Customers should provide appropriate design and operating safeguards to minimize the risks associated with their applications and products.

Nexperia does not accept any liability related to any default, damage, costs or problem which is based on any weakness or default in the customer's applications or products, or the application or use by customer's third party customer(s). Customer is responsible for doing all necessary testing for the customer's applications and products using Nexperia products in order to avoid a default of the applications and the products or of the application or use by customer's third party customer(s). Nexperia does not accept any liability in this respect.

Limiting values — Stress above one or more limiting values (as defined in the Absolute Maximum Ratings System of IEC 60134) will cause permanent damage to the device. Limiting values are stress ratings only and (proper) operation of the device at these or any other conditions above those given in the Recommended operating conditions section (if present) or the Characteristics sections of this document is not warranted. Constant or repeated exposure to limiting values will permanently and irreversibly affect the quality and reliability of the device.

Terms and conditions of commercial sale — Nexperia products are sold subject to the general terms and conditions of commercial sale, as published at <http://www.nexperia.com/profile/terms>, unless otherwise agreed in a valid written individual agreement. In case an individual agreement is concluded only the terms and conditions of the respective agreement shall apply. Nexperia hereby expressly objects to applying the customer's general terms and conditions with regard to the purchase of Nexperia products by customer.

No offer to sell or license — Nothing in this document may be interpreted or construed as an offer to sell products that is open for acceptance or the grant, conveyance or implication of any license under any copyrights, patents or other industrial or intellectual property rights.

Export control — This document as well as the item(s) described herein may be subject to export control regulations. Export might require a prior authorization from competent authorities.

Translations — A non-English (translated) version of a document is for reference only. The English version shall prevail in case of any discrepancy between the translated and English versions.

Trademarks

Notice: All referenced brands, product names, service names and trademarks are the property of their respective owners.

Contents

| | |
|--|-----------|
| 1. General description | 1 |
| 2. Features and benefits | 1 |
| 3. Ordering information | 1 |
| 4. Functional diagram | 2 |
| 5. Pinning information | 3 |
| 5.1. Pinning..... | 3 |
| 5.2. Pin description..... | 3 |
| 6. Functional description | 4 |
| 7. Limiting values | 5 |
| 8. Recommended operating conditions | 5 |
| 9. Static characteristics | 6 |
| 10. Dynamic characteristics | 7 |
| 10.1. Waveforms and test circuit..... | 8 |
| 11. Application information | 10 |
| 12. Package outline | 11 |
| 13. Revision history | 12 |
| 14. Legal information | 13 |

© Nexperia B.V. 2018. All rights reserved

For more information, please visit: <http://www.nexperia.com>
For sales office addresses, please send an email to: salesaddresses@nexperia.com
Date of release: 7 November 2018
