

SOT-23 Plastic-Encapsulate Transistors

HX2300A MOSFET(N-Channel)

FEATURES

TrenchFET Power MOSFET

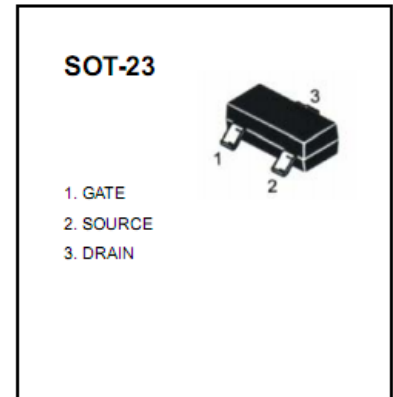
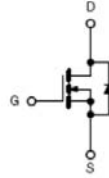

MARKING: 2300

MAXIMUM RATINGS (TA=25°C unless otherwise noted)

Symbol	Parameter	Value	Units
V _{DS}	Drain-Source voltage	20	V
V _{GS}	Gate-Source voltage	±12	V
I _D	Drain current	2.5	A
P _D	Power Dissipation	0.9	W
T _j	Junction Temperature	150	°C
T _{stg}	Storage Temperature	-55-150	°C

ELECTRICAL CHARACTERISTICS (T_{amb}=25°C unless otherwise specified)

Parameter	Symbol	Test conditions	MIN	TYP	MAX	UNIT
Drain-Source Breakdown Voltage	V _{(BR)DSS}	V _{GS} =0V, I _D =250uA	20			V
Gate-Threshold Voltage	V _{th(GS)}	V _{DS} =V _{GS} , I _D =250 uA	0.5	0.75	1.2	V
Gate-body Leakage	I _{GSS}	V _{DS} =0V, V _{GS} =±10V			±100	nA
Zero Gate Voltage Drain Current	I _{DSS}	V _{DS} =20V, V _{GS} =0V			1	uA
Drain-Source On-Resistance	r _{DS(ON)}	V _{GS} =2.5V, I _D =2A		58	82	mΩ
		V _{GS} =4.5V, I _D =2.5A		43	59	mΩ
Forward Trans conductance	g _{fs}	V _{DS} =5V, I _D =2.9A		9.5		s
Dynamic Characteristics						
Input Capacitance	C _{iss}	V _{DS} =10V, V _{GS} =0V, f=1MHz		280		pF
Output Capacitance	C _{oss}			60		
Reverse Transfer Capacitance	C _{rss}			40		
Switching Capacitance						
Turn-on Delay Time	t _{d(on)}	V _{DD} =10V, I _D =2.5A, V _{GS} =4.5V R _{GEN} =2.8Ω		6		nS
Turn-on Rise Time	t _r			5		nS
Turn-off Delay Time	t _{d(off)}			9		nS
Turn-off Fall Time	t _f			1.5		nS
Total Gate Charge	Q _g	V _{DS} =10V, I _D =2.5A, V _{GS} =4.5V,		1.7		nC
Gate-Source Charge	Q _{gs}			0.3		nC
Gate-Drain Charge	Q _{gd}			0.8		nC
Drain-Source Diode Characteristics						
Diode Forward Voltage	V _{SD}	V _{GS} =0V, I _S =2.5A			1.2	V
Diode Forward Current	I _S				2.5	A

Typical Characteristics

HX2300A

Switch Time Test Circuit and Switching Waveforms:

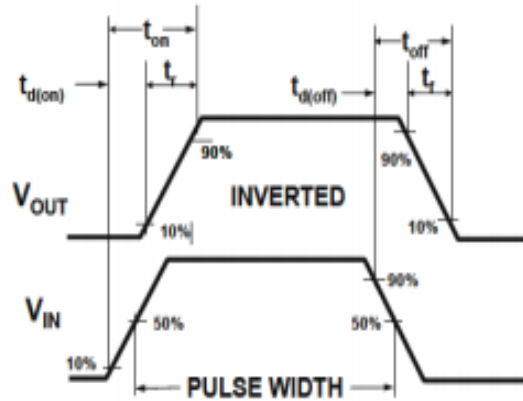
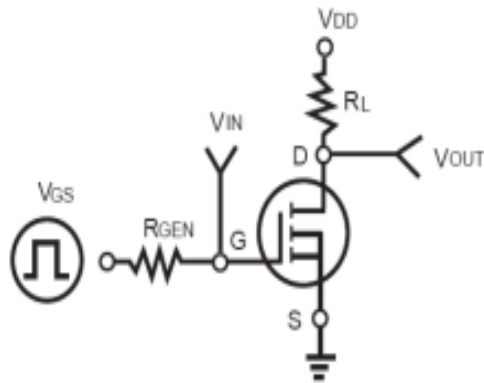

TYPICAL ELECTRICAL AND THERMAL CHARACTERISTICS (Curves)

Figure1. Power Dissipation

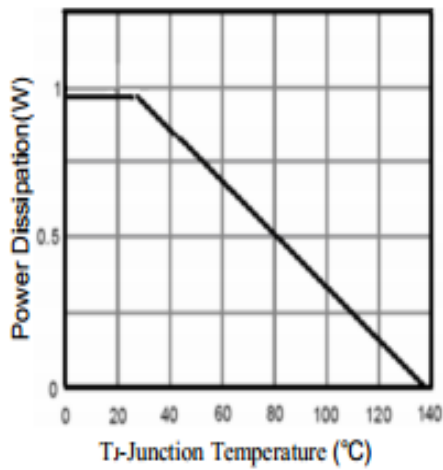

Figure2. Drain Current

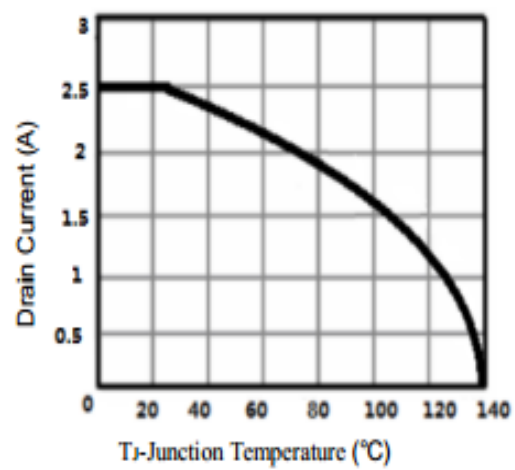

Figure3. Output Characteristics

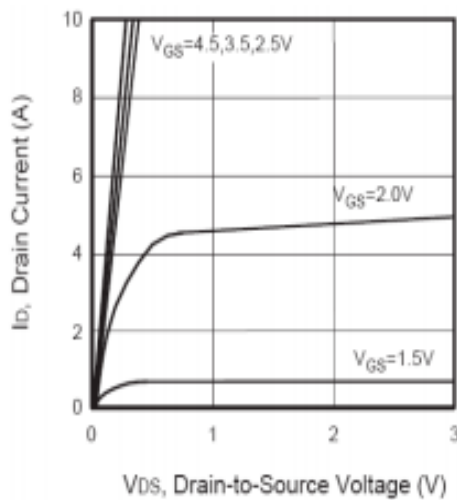

Figure4. Transfer Characteristics

