

ILD1151

Multitopology High Power LED DC/DC
Controller for Industrial Applications

Datasheet

Rev. 1.1, 2012-04-11

Table of Contents

1	Overview	3
2	Block Diagram	5
3	Pin Configuration	6
3.1	Pin Assignment	6
3.2	Pin Definitions and Functions	6
4	General Product Characteristics	8
4.1	Absolute Maximum Ratings	8
4.2	Functional Range	9
4.3	Thermal Resistance	10
5	Switching Regulator	11
5.1	Description	11
5.2	Electrical Characteristics	12
6	Oscillator and Synchronization	14
6.1	Description	14
6.2	Electrical Characteristics	15
7	Enable and Dimming Function	17
7.1	Description	17
7.2	Electrical Characteristics	18
8	Linear Regulator	20
8.1	Description	20
8.2	Electrical Characteristics	21
9	Protection and Diagnostic Functions	22
9.1	Description	22
9.2	Electrical Characteristics	27
10	Analog Dimming	28
10.1	Purpose of Analog Dimming:	28
10.2	Description	28
10.3	Electrical Characteristics	32
11	Application Information	33
11.1	Further Application Information	39
12	Package Outlines	40
13	Revision History	41

ILD1151



1 Overview

Features

- Wide Input Voltage Range from 4.5 V to 45 V
- Constant Current or Constant Voltage Regulation
- Drives LEDs in Boost, Buck, Buck-Boost, SEPIC and Flyback Topology
- Very Low Shutdown Current: $I_{q_OFF} < 10 \mu A$
- Flexible Switching Frequency Range, 100 kHz to 500 kHz
- Synchronization with external clock source
- PWM Dimming
- Analog Dimming feature to adjust average LED current
- Internal 5 V Low Drop Out Voltage Regulator
- Open Circuit Detection
- Short to GND Protection
- Output Overvoltage Protection
- Internal Soft Start
- Over Temperature Shutdown
- Wide LED current range via simple adaptation of external components
- 300mV High Side Current Sense to ensure highest flexibility and LED current accuracy
- Available in a small thermally enhanced PG-SSOP-14 package
- Green Product (RoHS) Compliant

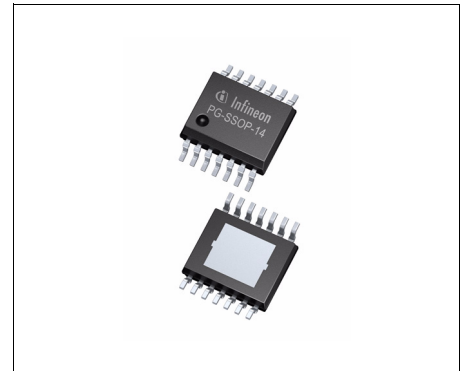

PG-SSOP-14

Description

The ILD1151 is a Multitopology High Power DC/DC Controller IC with built in protection features. The main function of this device is to regulate a constant LED current. The constant current regulation is especially beneficial for LED color accuracy and longer lifetime. The controller concept of the ILD1151 allows multiple configurations such as Boost, Buck, Buck-Boost, SEPIC and Flyback by simply adjusting the external components. The ILD1151 offers the most flexible dimming options. Dimming can be achieved with analog or PWM input. The switching frequency is adjustable in the range of 100 kHz to 500 kHz and can be synchronized to an external clock source. The ILD1151 features an enable function reducing the shut-down current consumption to $I_{q_OFF} < 10 \mu A$. The current mode regulation scheme of this device provides a stable regulation loop maintained by small external compensation components. The integrated soft start feature limits the current peak as well as voltage overshoot at start-up. This IC provides output overvoltage protection, device overtemperature shutdown and short circuit to GND protection.

Type	Package	Marking
ILD1151	PG-SSOP-14	ILD1151

Applications

- LED Controller for Industrial Applications
- Universal Constant Current and Voltage Source
- General Illumination e.g. Halogen Replacement
- Residential Architectural and Industrial Commercial Lighting for in- and outdoor
- Signal and Marker Lights for Orientation or Navigation (e.g. steps, exit ways, etc.)

For automotive and transportation applications, please refer to the Infineon® Auto LED products.

2 Block Diagram

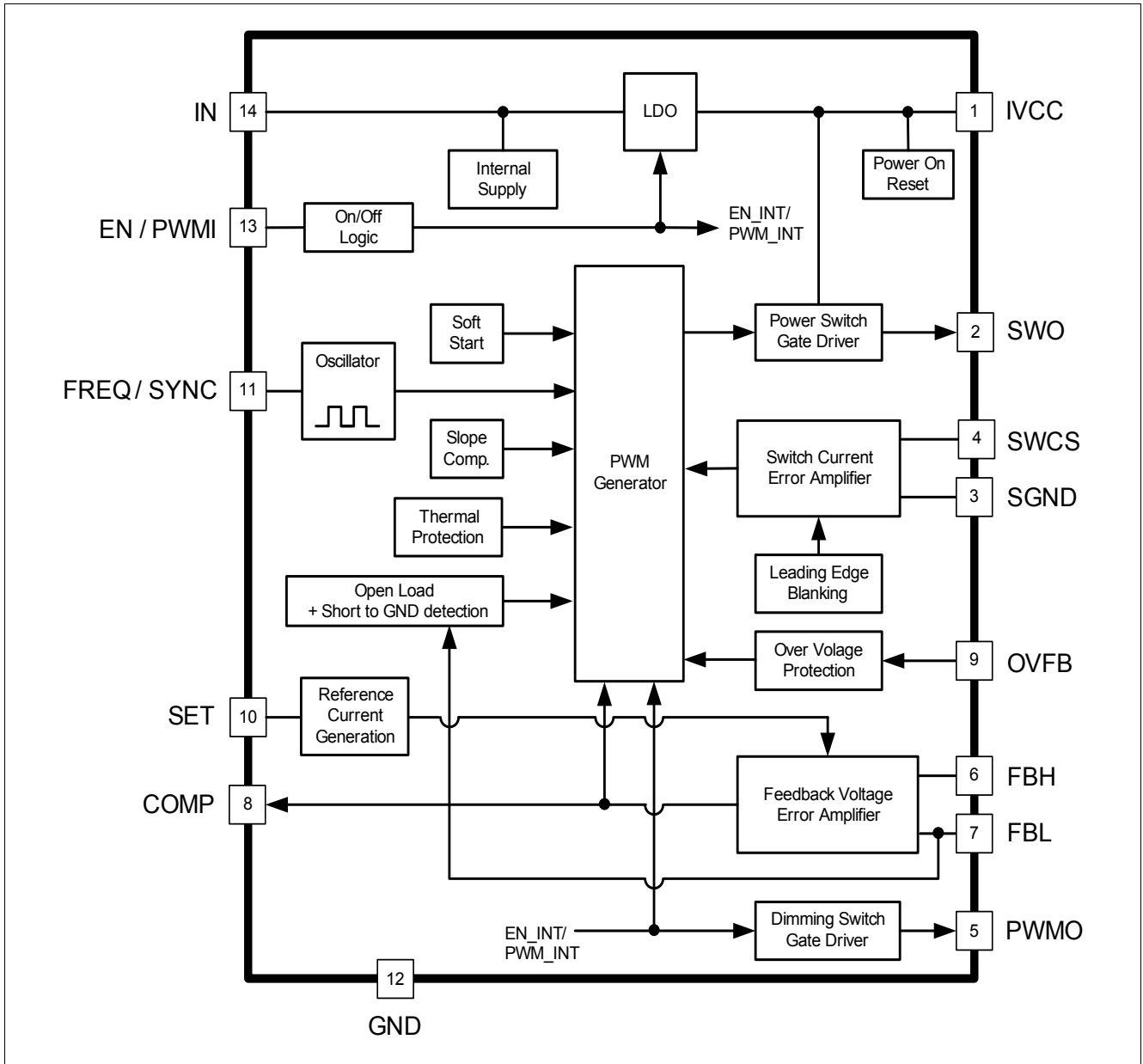

Figure 1 Block Diagram

3 Pin Configuration

3.1 Pin Assignment

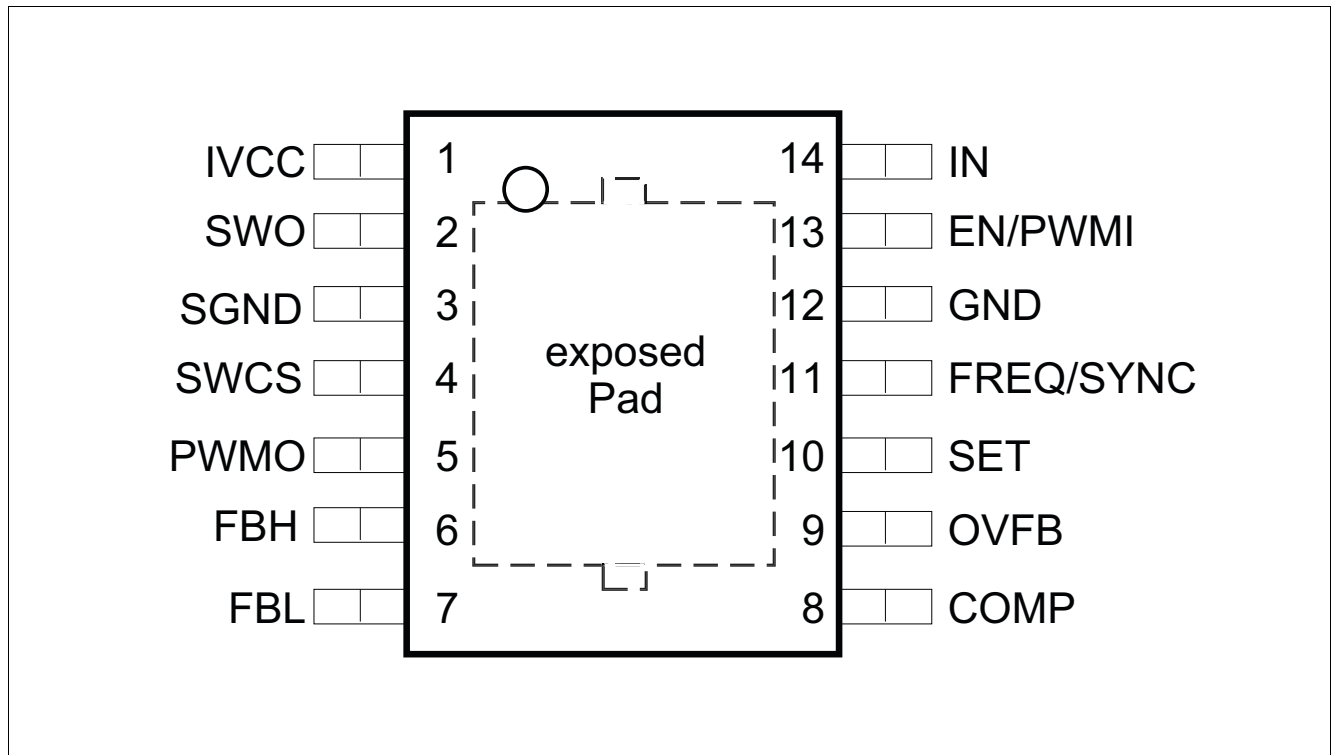

Figure 2 Pin Configuration

3.2 Pin Definitions and Functions

Pin	Symbol	Function
1	IVCC	Internal LDO Output; Used for internal biasing and gate drive. Bypass with external capacitor close to the pin. Pin must not be left open.
2	SWO	Switch Output; Connect to gate of external switching MOSFET
3	SGND	Current Sense Ground; Ground return for current sense switch
4	SWCS	Current Sense Input; Detects the peak current through switch
5	PWMO	PWM Dimming Output; Connect to gate of external MOSFET
6	FBH	Voltage Feedback Positive; Non inverting Input (+)
7	FBL	Voltage Feedback Negative; Inverting Input (-)
8	COMP	Compensation Input; Connect R and C network to pin for stability

Pin Configuration

Pin	Symbol	Function
9	OVFB	Output Overvoltage Protection Feedback; Connect to resistive voltage divider to set overvoltage threshold.
10	SET	Analog Dimming Input; Load current adjustment Pin. Pin must not be left open. If analog dimming feature is not used connect to IVCC pin.
11	FREQ / SYNC	Frequency Select or Synchronization Input; Connect external resistor to GND to set frequency. Or apply external clock signal for synchronization within frequency capture range.
12	GND	Ground; Connect to system ground.
13	EN / PWMI	Enable or PWM Input; Apply logic HIGH signal to enable device or PWM signal for dimming LED.
14	IN	Supply Input; Supply for internal biasing.
EP		Exposed Pad; Connect to external heatspreading GND Cu area (e.g. inner GND layer of multilayer PCB with thermal vias).

4 General Product Characteristics

4.1 Absolute Maximum Ratings

Absolute Maximum Ratings¹⁾

$T_j = -40\text{ °C}$ to $+125\text{ °C}$; all voltages with respect to ground, positive current flowing into pin (unless otherwise specified)

Pos.	Parameter	Symbol	Limit Values		Unit	Conditions
			Min.	Max.		
Voltages						
4.1.1	IN Supply Input	V_{IN}	-0.3	45	V	–
4.1.2	EN / PWMI Enable or PWM Input	V_{EN}	-40	45	V	–
4.1.3	FBH-FBL Feedback Error Amplifier Differential	$V_{FBH} - V_{FBL}$	-40	61	V	The maximum delta must not exceed 61V
4.1.4	FBH Feedback Error Amplifier Positive Input	V_{FBH}	-40	61	V	The difference between V_{FBH} and V_{FBL} must not exceed 61V, refer to Parameter 4.1.3
4.1.5	FBL Feedback Error Amplifier Negative Input	V_{FBL}	-40	61	V	The difference between V_{FBH} and V_{FBL} must not exceed 61V, refer to Parameter 4.1.3
4.1.6	FBH and FBL current	$I_{FBL,FBH}$	–	1	mA	$t < 100\text{ms}$, $V_{FBH} - V_{FBL} = 0.3\text{V}$
4.1.7	OVFB	V_{OVP}	-0.3	5.5	V	–
4.1.8	Over Voltage Feedback Input		-0.3	6.2	V	$t < 10\text{s}$
4.1.9	SWCS	V_{SWCS}	-0.3	5.5	V	–
4.1.10	Switch Current Sense Input		-0.3	6.2	V	$t < 10\text{s}$
4.1.11	SWO	V_{SWO}	-0.3	5.5	V	–
4.1.12	Switch Gate Drive Output		-0.3	6.2	V	$t < 10\text{s}$
4.1.13	SGND Current Sense Switch GND	V_{SGND}	-0.3	0.3	V	–
4.1.14	COMP	V_{COMP}	-0.3	5.5	V	–
4.1.15	Compensation Input		-0.3	6.2	V	$t < 10\text{s}$
4.1.16	FREQ / SYNC; Frequency and	$V_{FREQ / SYNC}$	-0.3	5.5	V	–
4.1.17	Synchronization Input		-0.3	6.2	V	$t < 10\text{s}$
4.1.18	PWMO	V_{PWMO}	-0.3	5.5	V	–
4.1.19	PWM Dimming Output		-0.3	6.2	V	$t < 10\text{s}$
4.1.20	SET	V_{SET}	-0.3	45	V	–
4.1.21	IVCC	V_{IVCC}	-0.3	5.5	V	–
4.1.22	Internal Linear Voltage Regulator Output		-0.3	6.2	V	$t < 10\text{s}$
Temperatures						
4.1.23	Junction Temperature	T_j	-40	150	°C	–

Absolute Maximum Ratings¹⁾

$T_j = -40\text{ °C}$ to $+125\text{ °C}$; all voltages with respect to ground, positive current flowing into pin (unless otherwise specified)

Pos.	Parameter	Symbol	Limit Values		Unit	Conditions
			Min.	Max.		
4.1.24	Storage Temperature	T_{stg}	-55	150	°C	–

ESD Susceptibility

4.1.25	ESD Resistivity of all Pins	$V_{ESD,HBM}$	-2	2	kV	HBM ²⁾
4.1.26	ESD Resistivity of IN, EN/PWMI, FBH, FBL and SET pin to GND	$V_{ESD,HBM}$	-4	4	kV	HBM ²⁾

1) Not subject to production test, specified by design.

2) ESD susceptibility, Human Body Model "HBM" according to ANSI/ESDA/JEDEC JS-001 (1.5kΩ, 100pF)

Note: Stresses above the ones listed here may cause permanent damage to the device. Exposure to absolute maximum rating conditions for extended periods may affect device reliability.

Note: Integrated protection functions are designed to prevent IC destruction under fault conditions described in the data sheet. Fault conditions are considered as "outside" normal operating range. Protection functions are not designed for continuous repetitive operation.

4.2 Functional Range

Pos.	Parameter	Symbol	Limit Values		Unit	Conditions
			Min.	Max.		
4.2.1	Supply Voltage Range	V_{IN}	4.5	45 ¹⁾	V	$V_{IVCC} > V_{IVCC,RTH,d}$
4.2.2	Feedback Voltage Input	$V_{FBH};$ V_{FBL}	3	60	V	–
4.2.3	Junction Temperature	T_j	-40	125	°C	–

1) Not subject to production test, specified by design.

Note: Within the functional range the IC operates as described in the circuit description. The electrical characteristics are specified within the conditions given in the related electrical characteristics table.

4.3 Thermal Resistance

Note: This thermal data was generated in accordance with JEDEC JESD51 standards. For more information, go to www.jedec.org.

Pos.	Parameter	Symbol	Limit Values			Unit	Conditions
			Min.	Typ.	Max.		
4.3.1	Junction to Case ^{1) 2)}	R_{thJC}	–	10	–	K/W	–
4.3.2	Junction to Ambient ^{1) 3)}	R_{thJA}	–	47	–	K/W	2s2p
4.3.3		R_{thJA}	–	54	–	K/W	1s0p + 600 mm ²
4.3.4		R_{thJA}	–	64	–	K/W	1s0p + 300 mm ²

- 1) Not subject to production test, specified by design.
- 2) Specified R_{thJC} value is simulated at natural convection on a cold plate setup (all pins and the exposed pad are fixed to ambient temperature). $T_a=25^{\circ}\text{C}$; The IC is dissipating 1W.
- 3) Specified R_{thJA} value is according to JEDEC 2s2p (JESD 51-7) + (JESD 51-5) and JEDEC 1s0p (JESD 51-3) + heatsink area at natural convection on FR4 board; The device was simulated on a 76.2 x 114.3 x 1.5 mm board. The 2s2p board has 2 outer copper layers (2 x 70 μm Cu) and 2 inner copper layers (2 x 35 μm Cu). A thermal via (diameter = 0.3 mm and 25 μm plating) array was applied under the exposed pad and connected the first outer layer (top) to the first inner layer and second outer layer (bottom) of the JEDEC PCB. $T_a=25^{\circ}\text{C}$; The IC is dissipating 1W.

5 Switching Regulator

5.1 Description

The ILD1151 regulator is suitable for Boost, Buck, Buck-Boost, SEPIC and Flyback configurations. The constant output current is especially useful for light emitting diode (LED) applications. The regulator function is implemented by a pulse width modulated (PWM) current mode controller.

The PWM current mode controller uses the peak current through the external power switch and error in the output current to determine the appropriate pulse width duty cycle (on time) for constant output current. The current mode controller provides a PWM signal to an internal gate driver which then outputs to an external n-channel enhancement mode metal oxide field effect transistor (MOSFET) power switch.

The current mode controller also has built-in slope compensation to prevent sub-harmonic oscillations which is a characteristic of current mode controllers operating at high duty cycles (>50% duty).

An additional built-in feature is an integrated soft start that limits the current through the inductor and external power switch during initialization. The soft start function gradually increases the inductor and switch current over t_{SS} (Parameter 5.2.8) to minimize potential overvoltage at the output.

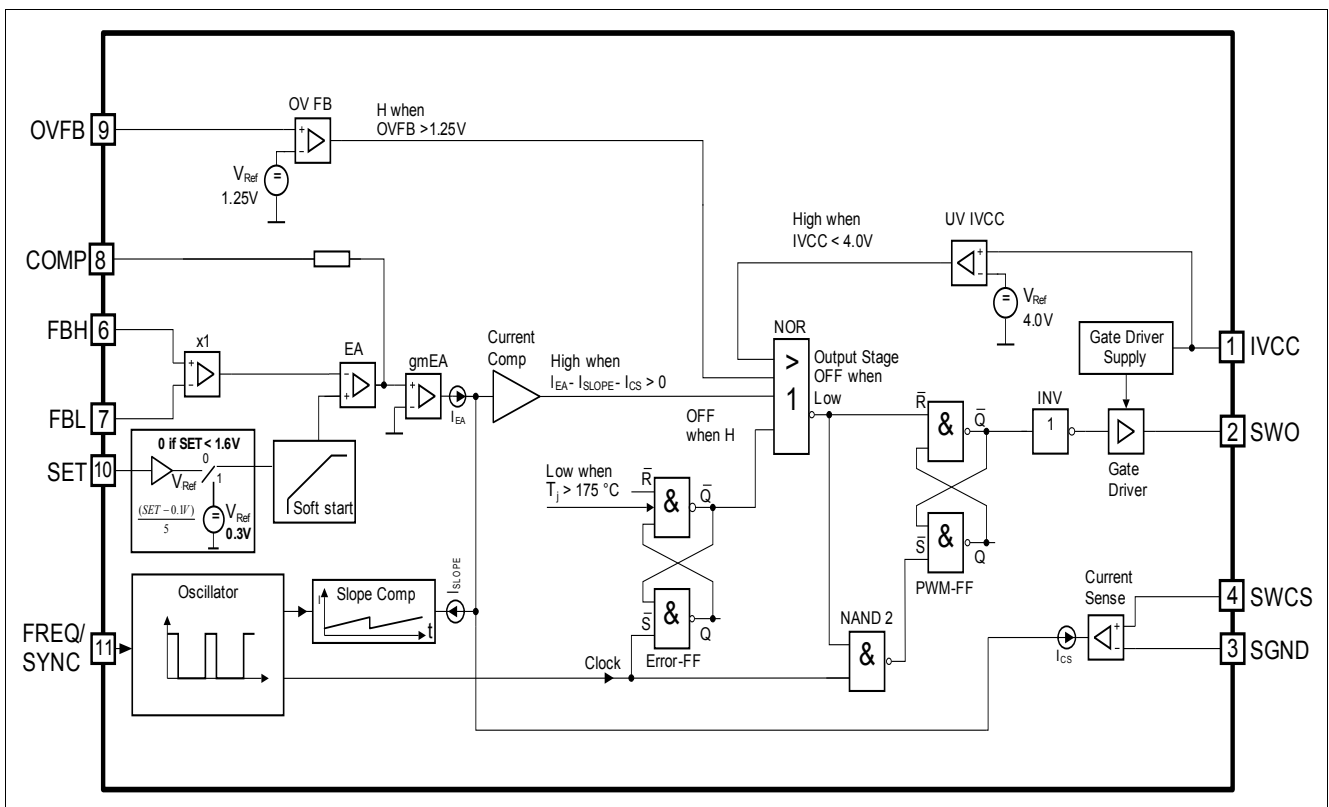

Figure 3 Switching Regulator Block Diagram

5.2 Electrical Characteristics

All parameters have been tested at 25°C, unless otherwise specified.

Table 1 EC Switching Regulator

$V_{IN} = 24V$; $T_j = -40\text{ °C}$ to $+125\text{ °C}$, all voltages with respect to ground, positive current flowing into pin; (unless otherwise specified)

Pos.	Parameter	Symbol	Limit Values			Unit	Conditions
			Min.	Typ.	Max.		
Regulator:							
5.2.1	Feedback Reference Voltage	V_{REF}	0.29	0.30	0.31	V	refer to Figure 29 $V_{REF} = V_{FBH} - V_{FBL}$ $V_{SET} = 5V$ $I_{LED} = 350\text{ mA}$
5.2.2	Feedback Reference Voltage	V_{REF}	0.057	0.06	0.063	V	refer to Figure 29 $V_{REF} = V_{FBH} - V_{FBL}$ $V_{SET} = 0.4V$ $I_{LED} = 70\text{ mA}$
5.2.3	Feedback Reference Voltage Offset	V_{REF_offset}	–	–	5	mV	refer to Figure 17 and Figure 29 $V_{REF} = V_{FBH} - V_{FBL}$ $V_{SET} = 0.1V$ $V_{OUT} > V_{IN}$
5.2.4	Voltage Load Regulation	$(\Delta V_{REF} / V_{REF}) / \Delta I_{BO}$	–	–	5	%/A	refer to Figure 29 $V_{SET} = 5V$; $I_{LED} = 100\text{ to }500\text{ mA}$
5.2.5	Switch Peak Over Current Threshold	V_{SWCS}	130	150	170	mV	$V_{FBH} = V_{FBL} = 5V$ $V_{COMP} = 3.5V$
5.2.6	Maximum Duty Cycle	$D_{MAX, fixed}$	91	93	95	%	Fixed frequency mode
5.2.7	Maximum Duty Cycle	$D_{MAX, sync}$	88	–	–	%	Synchronization mode
5.2.8	Soft Start Ramp	t_{SS}	350	1000	1500	μs	V_{FB} rising from 5% to 95% of V_{FB} , typ.
5.2.9	IFBH Feedback High Input Current	I_{FBH}	38	46	54	μA	$V_{FBH} - V_{FBL} = 0.3V$
5.2.10	IFBL Feedback Low Input Current	I_{FBL}	15	21	27	μA	$V_{FBH} - V_{FBL} = 0.3V$
5.2.11	Switch Current Sense Input Current	I_{SWCS}	10	50	100	μA	$V_{SWCS} = 150\text{ mV}$
5.2.12	Input Undervoltage Shutdown	$V_{IN, off}$	3.5	–	4.5	V	V_{IN} decreasing
5.2.13	Input Voltage Startup	$V_{IN, on}$	–	–	4.85	V	V_{IN} increasing

1) Not subject to production test, specified by design

Table 1 EC Switching Regulator

$V_{IN} = 24V$; $T_j = -40\text{ °C}$ to $+125\text{ °C}$, all voltages with respect to ground, positive current flowing into pin; (unless otherwise specified)

Pos.	Parameter	Symbol	Limit Values			Unit	Conditions
			Min.	Typ.	Max.		
Gate Driver for external Switch							
5.2.14	Gate Driver Peak Sourcing Current	$I_{SWO, SRC}$	–	380	–	mA	¹⁾ $V_{SWO} = 1V$ to $4V$
5.2.15	Gate Driver Peak Sinking Current	$I_{SWO, SNK}$	–	550	–	mA	¹⁾ $V_{SWO} = 4V$ to $1V$
5.2.16	Gate Driver Output Rise Time	$t_{R, SWO}$	–	30	60	ns	¹⁾ $C_{L, SWO} = 3.3nF$; $V_{SWO} = 1V$ to $4V$
5.2.17	Gate Driver Output Fall Time	$t_{F, SWO}$	–	20	40	ns	¹⁾ $C_{L, SWO} = 3.3nF$; $V_{SWO} = 4V$ to $1V$
5.2.18	Gate Driver Output Voltage	V_{SWO}	4.5	–	5.5	V	¹⁾ $C_{L, SWO} = 3.3nF$;

1) Not subject to production test, specified by design

6 Oscillator and Synchronization

6.1 Description

The internal oscillator is used to determine the switching frequency of the boost regulator. The switching frequency can be selected from 100 kHz to 500 kHz with an external resistor to GND. To set the switching frequency with an external resistor the following formula can be applied.

$$R_{FREQ} = \frac{1}{\left(141 \times 10^{-12} \left[\frac{s}{\Omega}\right]\right) \times \left(f_{FREQ} \left[\frac{1}{s}\right]\right)} - \left(3.5 \times 10^3 [\Omega]\right) [\Omega]$$

In addition, the oscillator is capable of changing from the frequency set by the external resistor to a synchronized frequency from an external clock source. If an external clock source is provided on the pin FREQ/SYNC, then the internal oscillator synchronizes to this external clock frequency and the boost regulator switches at the synchronized frequency. The synchronization frequency capture range is 250 kHz to 500 kHz.

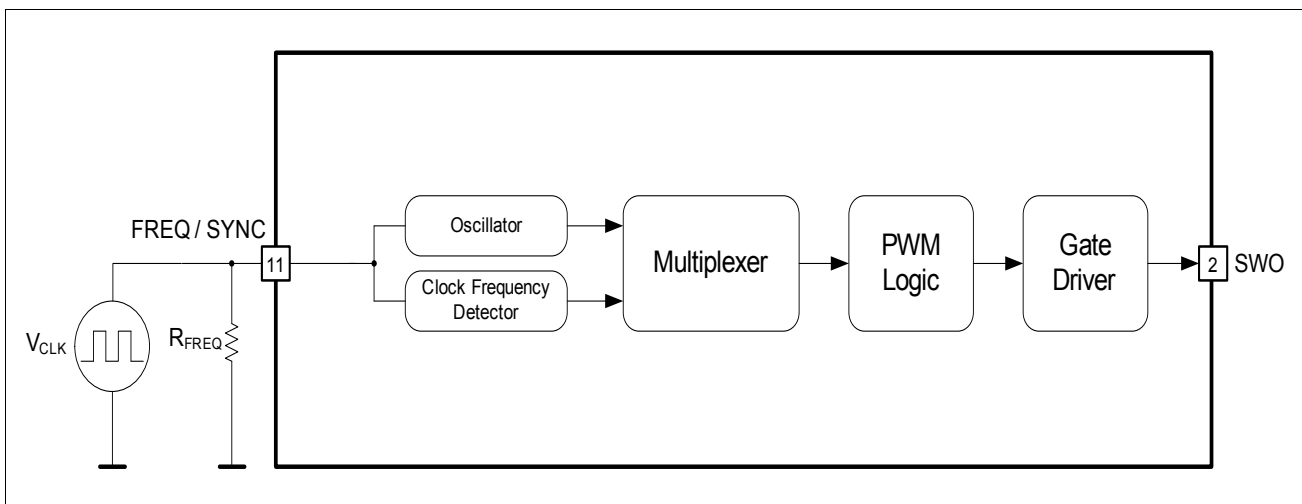

Figure 4 Oscillator and Synchronization Block Diagram and Simplified Application Circuit

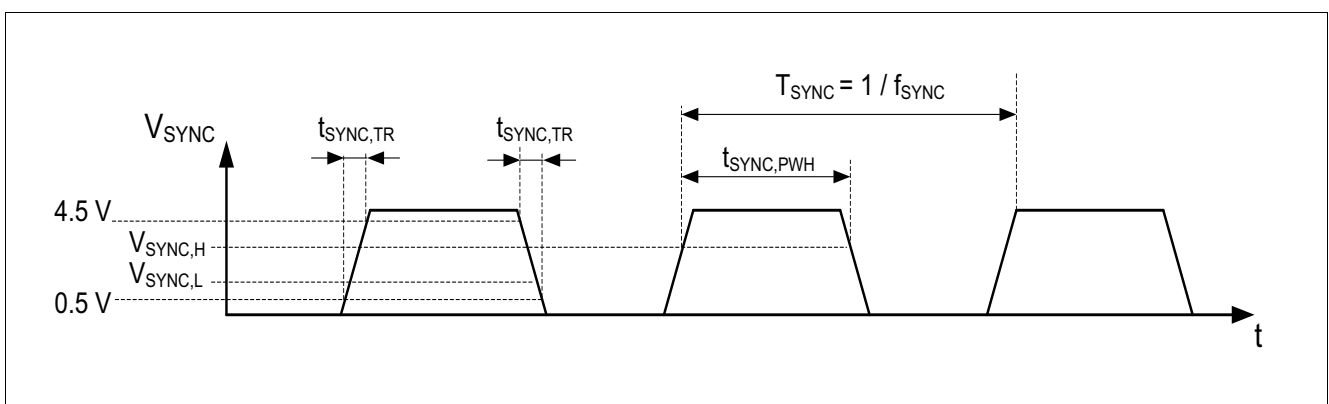

Figure 5 Synchronization Timing Diagram

6.2 Electrical Characteristics

All parameters have been tested at 25°C, unless otherwise specified.

Table 2 EC Oscillator and Synchronization

$V_{IN} = 24V$; $T_j = -40\text{ °C}$ to $+125\text{ °C}$, all voltages with respect to ground, positive current flowing into pin; (unless otherwise specified)

Pos.	Parameter	Symbol	Limit Values			Unit	Conditions
			Min.	Typ.	Max.		
Oscillator:							
6.2.1	Oscillator Frequency	f_{FREQ}	250	300	350	kHz	$R_{FREQ} = 20k\Omega$
6.2.2	Oscillator Frequency Adjustment Range	f_{FREQ}	100	–	500	kHz	
6.2.3	FREQ / SYNC Supply Current	I_{FREQ}	–	–	-700	μA	$V_{FREQ} = 0V$
6.2.4	Frequency Voltage	V_{FREQ}	1.16	1.24	1.32	V	$f_{FREQ} = 100kHz$
Synchronization							
6.2.5	Synchronization Frequency Capture Range	f_{SYNC}	250	–	500	kHz	–
6.2.6	Synchronization Signal High Logic Level Valid	$V_{SYNC,H}$	3.0	–	–	V	^{1) 2)}
6.2.7	Synchronization Signal Low Logic Level Valid	$V_{SYNC,L}$	–	–	0.8	V	^{1) 2)}
6.2.8	Synchronization Signal Logic High Pulse Width	$t_{SYNC,PWH}$	200	–	–	ns	^{1) 2)}

1) Synchronization of external PWM ON signal to falling edge

2) Not subject to production test, specified by design

Typical Performance Characteristics of Oscillator

Switching Frequency f_{SW} versus
Frequency Select Resistor to GND $R_{FREQ/SYNC}$

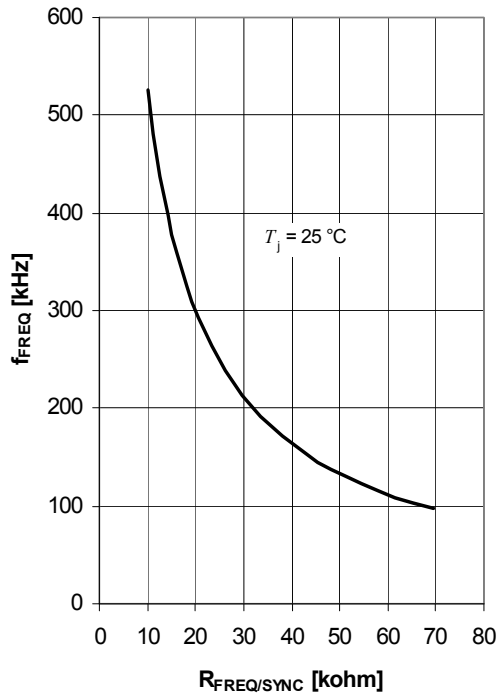

7 Enable and Dimming Function

7.1 Description

The enable function powers ON or OFF the device. A valid logic LOW signal on enable pin EN/PWMI powers OFF the device and current consumption is less than I_{Q_OFF} (Parameter 7.2.14). A valid logic HIGH enable signal on enable pin EN/PWMI powers on the device. The enable function features an integrated pull down resistor which ensures that the IC is shut down and the power switch is OFF in case the enable pin EN is left open.

In addition to the enable function described above, the EN/PWMI pin detects a pulse width modulated (PWM) input signal that is fed through to an internal gate driver. The internal gate driver outputs the same PWM signal on the PWMO pin to an external N-channel enhancement mode MOSFET for PWM dimming an LED load. PWM dimming an LED is a commonly practiced dimming method and can prevent color shift in an LED light source. Moreover the PWM output function may also be used to drive other types of loads besides LED.

The enable and PWM input function share the same pin. Therefore a valid logic LOW signal at the EN/PWMI pin needs to differentiate between an enable power OFF or an PWM dimming LOW signal. The device differentiates between enable OFF and PWM dimming signal by requiring the enable OFF at the EN/PWMI pin to stay LOW for the Enable Turn OFF Delay Time ($t_{EN,OFF,DEL}$ Parameter 7.2.6).

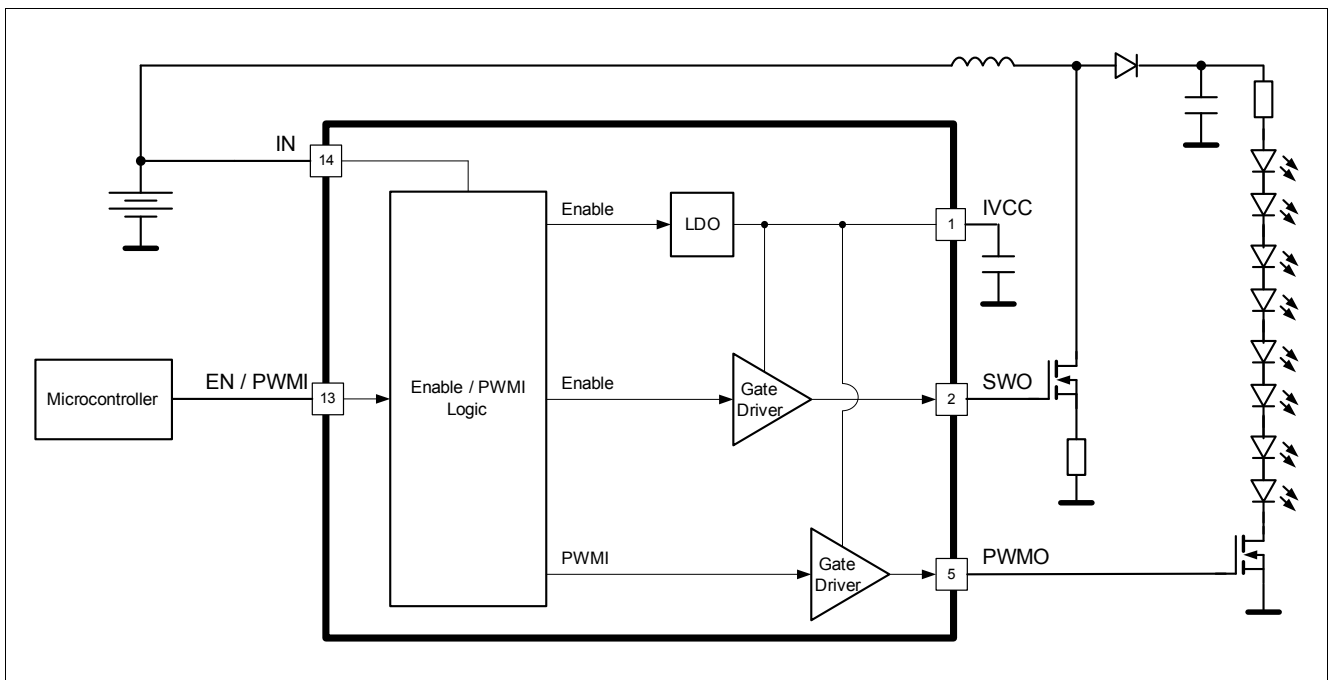
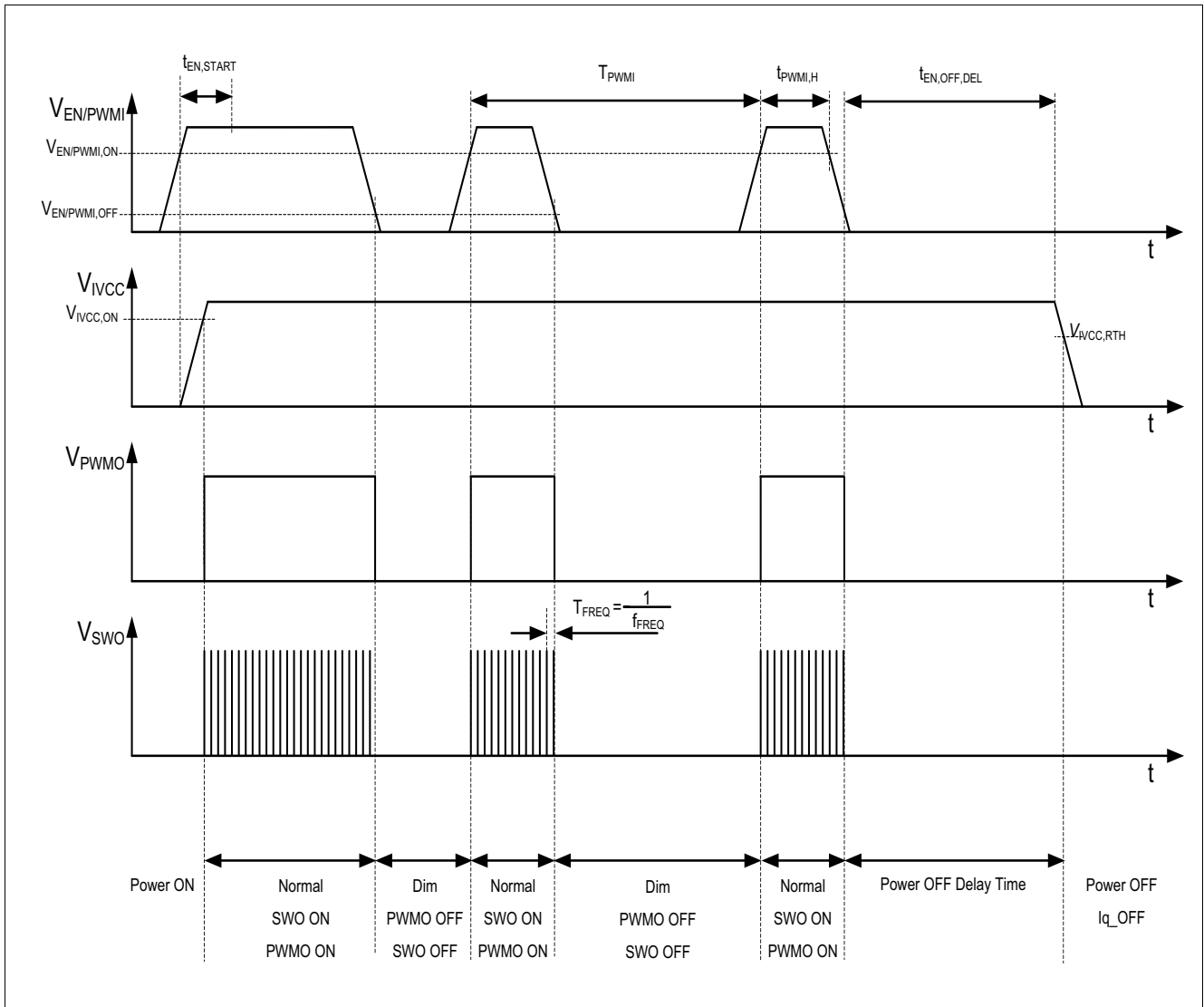

Figure 6 Block Diagram and Simplified Application Circuit Enable and LED Dimming

Figure 7 Timing Diagram Enable and LED Dimming

7.2 Electrical Characteristics

All parameters have been tested at 25°C, unless otherwise specified.

Table 3 EC Enable and Dimming

$V_{IN} = 24V$; $T_j = -40\text{ °C to }+125\text{ °C}$, all voltages with respect to ground, positive current flowing into pin; (unless otherwise specified)

Pos.	Parameter	Symbol	Limit Values			Unit	Conditions
			Min.	Typ.	Max.		
Enable/PWM Input:							
7.2.1	Enable/PWMI Turn On Threshold	$V_{EN/PWMI,ON}$	3.0	–		V	–
7.2.2	Enable/PWMI Turn Off Threshold	$V_{EN/PWMI,OFF}$	–	–	0.8	V	–

Enable and Dimming Function

Table 3 EC Enable and Dimming
 $V_{IN} = 24V$; $T_j = -40\text{ °C}$ to $+125\text{ °C}$, all voltages with respect to ground, positive current flowing into pin; (unless otherwise specified)

Pos.	Parameter	Symbol	Limit Values			Unit	Conditions
			Min.	Typ.	Max.		
7.2.3	Enable/PWMI Hysteresis	$V_{EN/PWMI,HYS}$	50	200	400	mV	¹⁾
7.2.4	Enable/PWMI High Input Current	$I_{EN/PWMI,H}$	–	–	30	μA	$V_{EN/PWMI} = 16.0V$
7.2.5	Enable/PWMI Low Input Current	$I_{EN/PWMI,L}$	–	0.1	1	μA	$V_{EN/PWMI} = 0.5V$
7.2.6	Enable Turn Off Delay Time	$t_{EN,OFF,DEL}$	8	10	12	ms	–
7.2.7	PWMI Min Duty Time	$t_{PWMI,H}$	4	–	–	μs	–
7.2.8	Enable Startup Time	$t_{EN,START}$	100	–	–	μs	¹⁾

Gate Driver for Dimming Switch:

7.2.9	PWMO Gate Driver Peak Sourcing Current	$I_{PWMO,SRC}$	–	230	–	mA	¹⁾ $V_{PWMO} = 1V$ to $4V$
7.2.10	PWMO Gate Driver Peak Sinking Current	$I_{PWMO,SNK}$	–	370	–	mA	¹⁾ $V_{PWMO} = 4V$ to $1V$
7.2.11	PWMO Gate Driver Output Rise Time	$t_{R,PWMO}$	–	50	100	ns	¹⁾ $C_{L,PWMO} = 3.3nF$; $V_{PWMO} = 1V$ to $4V$
7.2.12	PWMO Gate Driver Output Fall Time	$t_{F,PWMO}$	–	30	60	ns	¹⁾ $C_{L,PWMO} = 3.3nF$; $V_{PWMO} = 4V$ to $1V$
7.2.13	PWMO Gate Driver Output Voltage	V_{PWMO}	4.5	–	5.5	V	¹⁾ $C_{L,PWMO} = 3.3nF$;

Current Consumption

7.2.14	Current Consumption, Shutdown Mode	I_{q_OFF}	–	–	10	μA	$V_{EN/PWMI} = 0.8V$; $T_j \leq 105C$; $V_{IN} = 16V$
7.2.15	Current Consumption, Active Mode ²⁾	I_{q_ON}	–	–	7	mA	$V_{EN/PWMI} \geq 4.75V$; $I_{BO} = 0mA$; $V_{SWO} = 0\%$ Duty Cycle

1) Not subject to production test, specified by design

2) Dependency on switching frequency and gate charge of boost and dimming switch.

8 Linear Regulator

8.1 Description

The internal linear voltage regulator supplies the internal gate drivers with a typical voltage of 5V and current up to $I_{LIM,min}$ (Parameter 8.2.2). An external output capacitor with ESR lower than $R_{IVCC,ESR}$ (Parameter 8.2.5) is required on pin IVCC for stability and buffering transient load currents. During normal operation the external boost and dimming MOSFET switches will draw transient currents from the linear regulator and its output capacitor. Proper sizing of the output capacitor must be considered to supply sufficient peak current to the gate of the external MOSFET switches.

Integrated undervoltage protection for the external switching MOSFET:

An integrated undervoltage reset threshold circuit monitors the linear regulator output voltage (V_{IVCC}) and resets the device in case the output voltage falls below the IVCC Undervoltage Reset switch OFF Threshold ($V_{IVCC,RTH,d}$ Parameter 8.2.7). The Undervoltage Reset threshold for the IVCC pin helps to protect the external switches from excessive power dissipation by ensuring the gate drive voltage is sufficient to enhance the gate of an external logic level N-channel MOSFET.

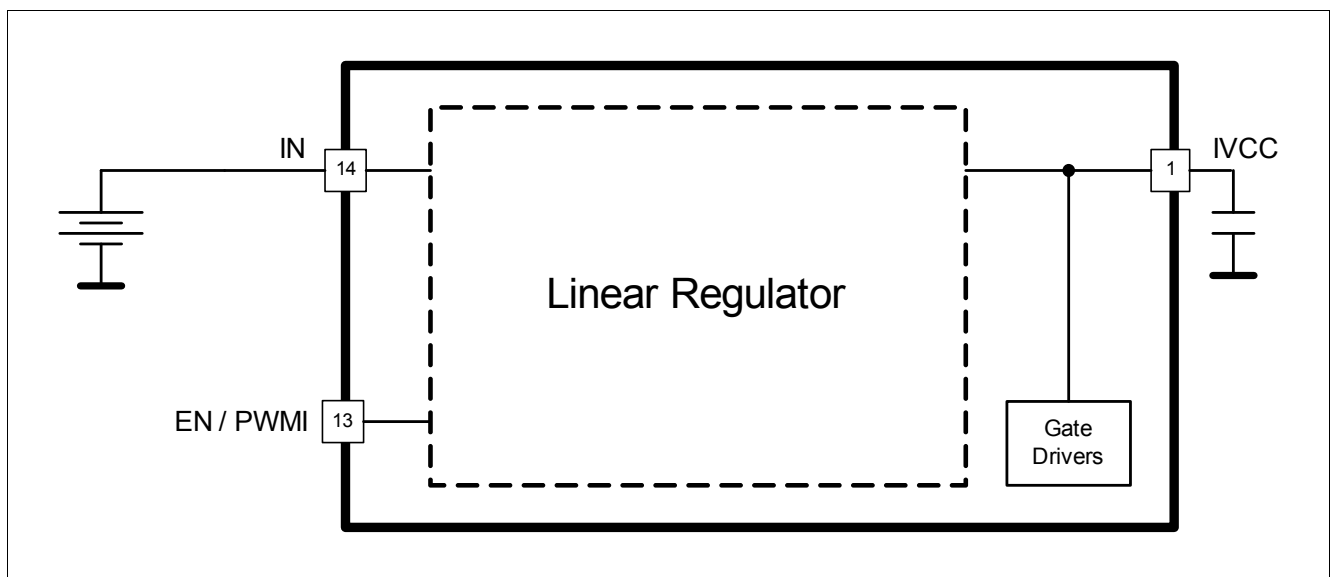

Figure 8 Voltage Regulator Block Diagram and Simplified Application Circuit

8.2 Electrical Characteristics

All parameters have been tested at 25°C, unless otherwise specified.

Table 4 EC Line Regulator

$V_{IN} = 24V$; $T_j = -40\text{ °C}$ to $+125\text{ °C}$, all voltages with respect to ground, positive current flowing into pin; (unless otherwise specified)

Pos.	Parameter	Symbol	Limit Values			Unit	Conditions
			Min.	Typ.	Max.		
8.2.1	Output Voltage	V_{IVCC}	4.85	5	5.15	V	$6V \leq V_{IN} \leq 45V$ $0.1mA \leq I_{IVCC} \leq 50mA$
8.2.2	Output Current Limitation	I_{LIM}	51	–	90	mA	$V_{IN} = 13.5V$ $V_{IVCC} = 4.5V$
8.2.3	Drop out Voltage	V_{DR}	–	–	0.5	V	$V_{IN} = 4.5V$ $I_{IVCC} = 25mA$
8.2.4	IVCC Buffer Capacitor	C_{IVCC}	0.47	1	100	μF	^{1) 2)}
8.2.5	IVCC Buffer Capacitor ESR	$R_{IVCC,ESR}$	–	–	0.5	Ω	¹⁾
8.2.6	Undervoltage Reset Headroom	$V_{IVCC,HDRM}$	100	–	–	mV	V_{IVCC} decreasing $V_{IVCC} - V_{IVCC,RTH,d}$
8.2.7	IVCC Undervoltage Reset switch OFF Threshold	$V_{IVCC,RTH,d}$	3.6	–	4.0	V	³⁾ V_{IVCC} decreasing.
8.2.8	IVCC Undervoltage Reset switch ON Threshold	$V_{IVCC,RTH,i}$	–	–	4.5	V	V_{IVCC} increasing

1) Not subject to production test, specified by design

2) Minimum value given is needed for regulator stability; application might need higher capacitance than the minimum.

3) Selection of external switching MOSFET is crucial and the $V_{IVCC,RTH,d}$ min. as worst case V_{GS} must be considered.

9 Protection and Diagnostic Functions

9.1 Description

The ILD1151 has integrated circuits to diagnose and protect against output overvoltage, open load, open feedback and overtemperature faults. Additionally the FBH and FBL potential is monitored and in case the LED load short circuits to GND (see description [Figure 15](#)) the regulator stops the operation and protects the system. In case any of the six fault conditions occur the PWM0 and IVCC signal will change to an active logic LOW signal to communicate that a fault has occurred (detailed overview in [Figure 9](#) and [Figure 10](#) below). [Figure 11](#) illustrates the various open load and open feedback conditions. In case of an overtemperature condition the integrated thermal shutdown function turns off the gate drivers and internal linear voltage regulator. The typical junction shutdown temperature is 175°C ($T_{j,SD}$ Parameter [9.2.2](#)). After cooling down the IC will automatically restart. Thermal shutdown is an integrated protection function designed to prevent IC destruction and is not intended for continuous use in normal operation ([Figure 13](#)). To calculate the proper overvoltage protection resistor values an example is given in [Figure 14](#).

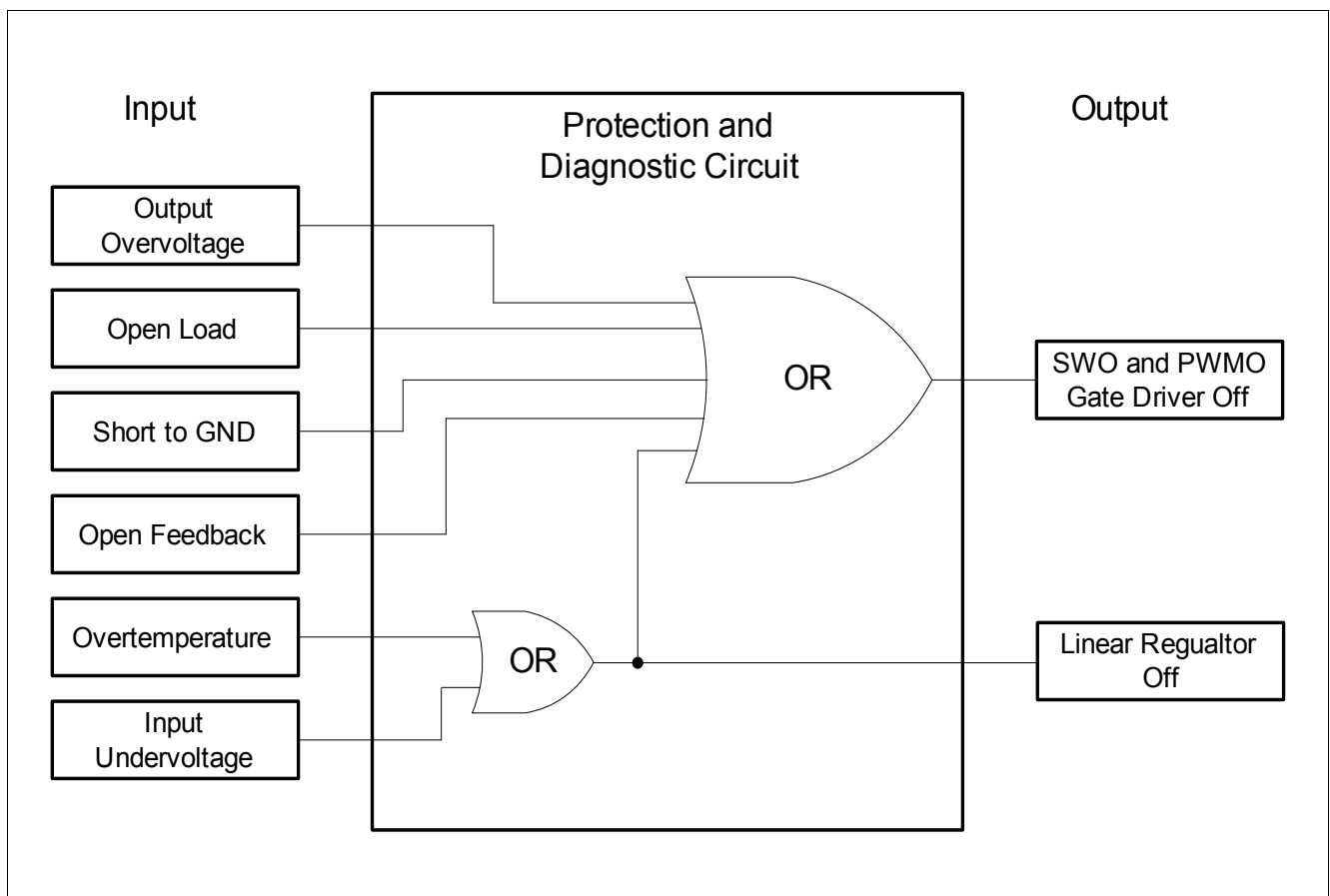

Figure 9 Protection and Diagnostic Function Block Diagram

Input		Output		
Condition	Level*	SWO	PWMO	IVCC
Overvoltage @ Output	False	Sw*	H or Sw*	Active
	True	L	L	Active
Open Load	False	Sw*	H or Sw*	Active
	True	L	L	Active
Short to GND @ LED chain	False	Sw*	H or Sw*	Active
	True	L	L	Active
Open Feedback	False	Sw*	H or Sw*	Active
	True	L	L	Active
Overtemperature	False	Sw*	H or Sw*	Active
	True	L	L	Shutdown
Undervoltage @ Input	False	Sw*	H or Sw*	Active
	True	L	L	Shutdown

*Note:

Sw = Switching

False = Condition does not exist

True = Condition does exist

Figure 10 Diagnosis Truth Table

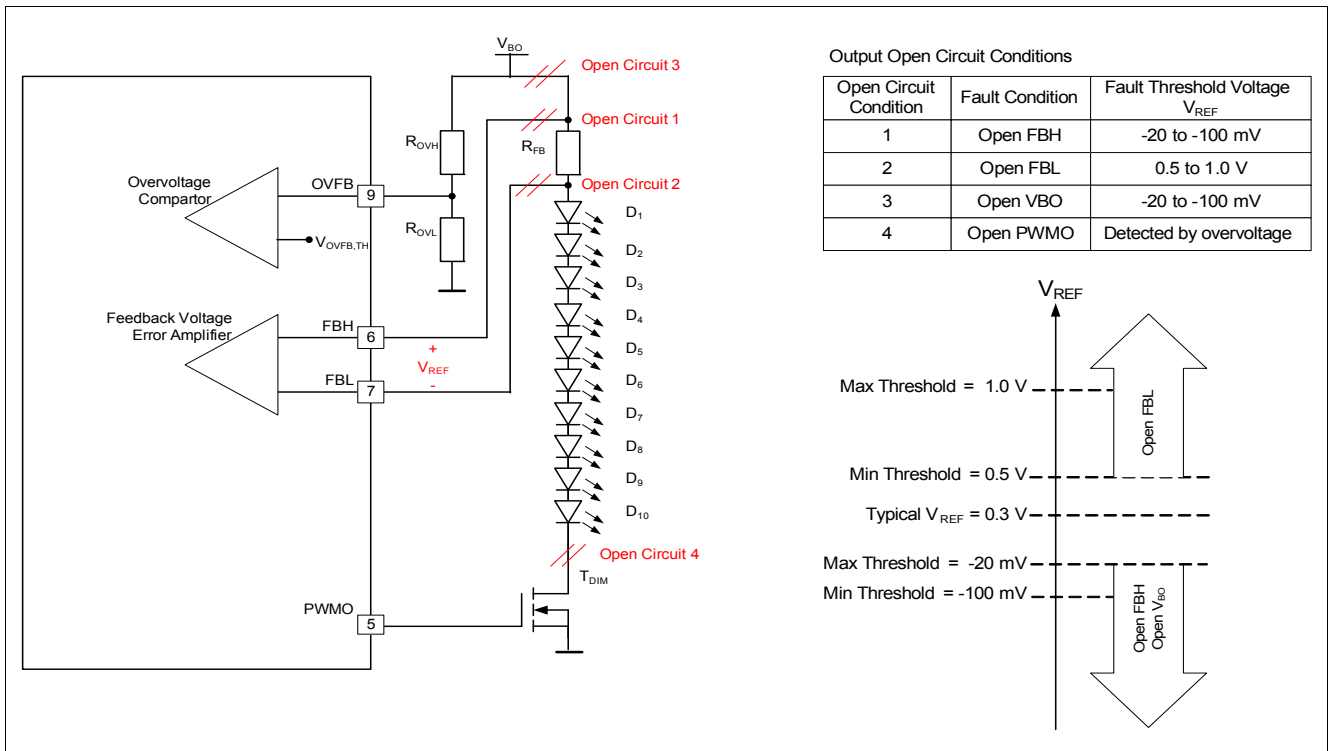

Figure 11 Open Load and Open Feedback Conditions

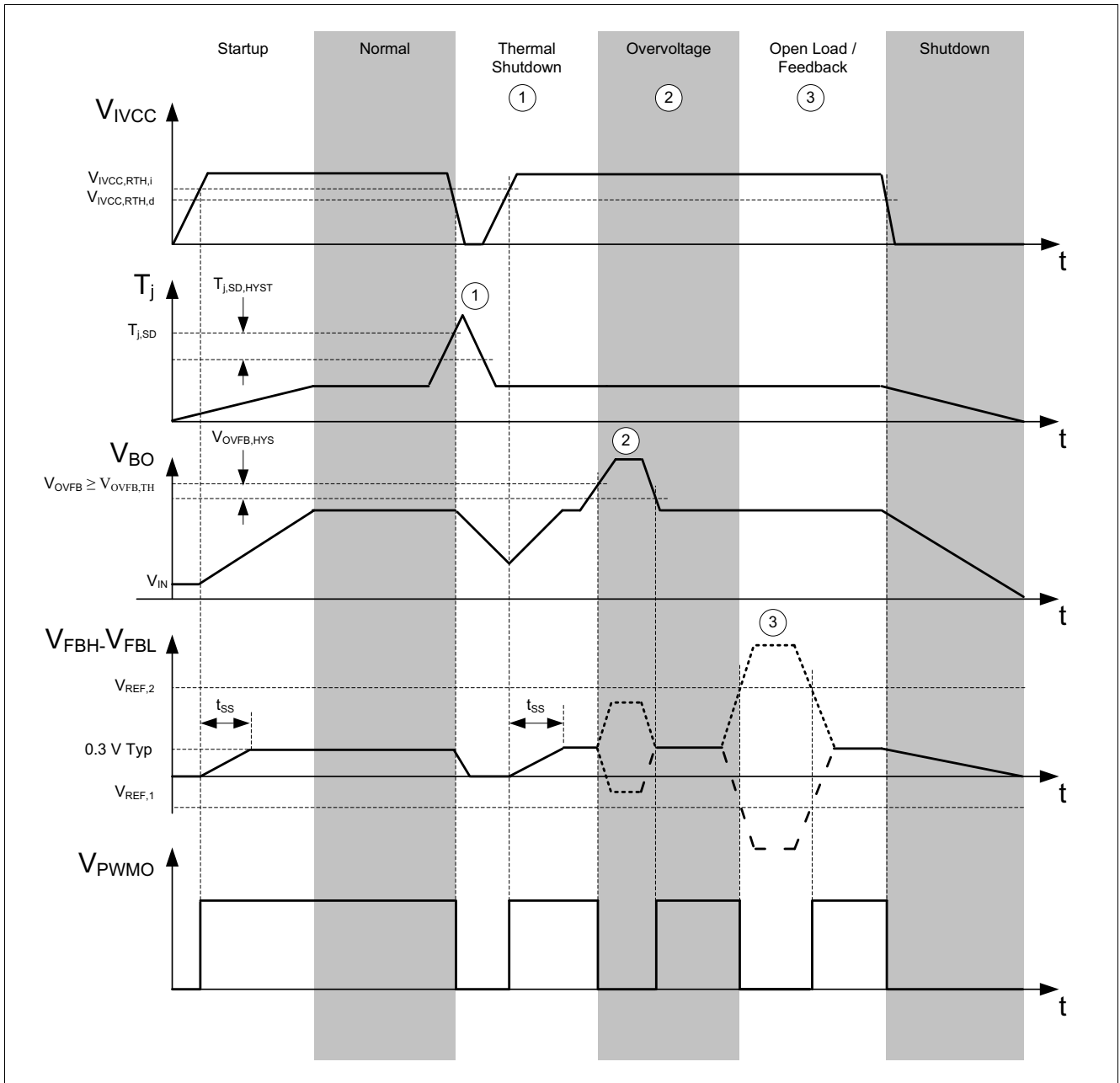

Figure 12 Open load, Overvoltage and Overtemperature Timing Diagram

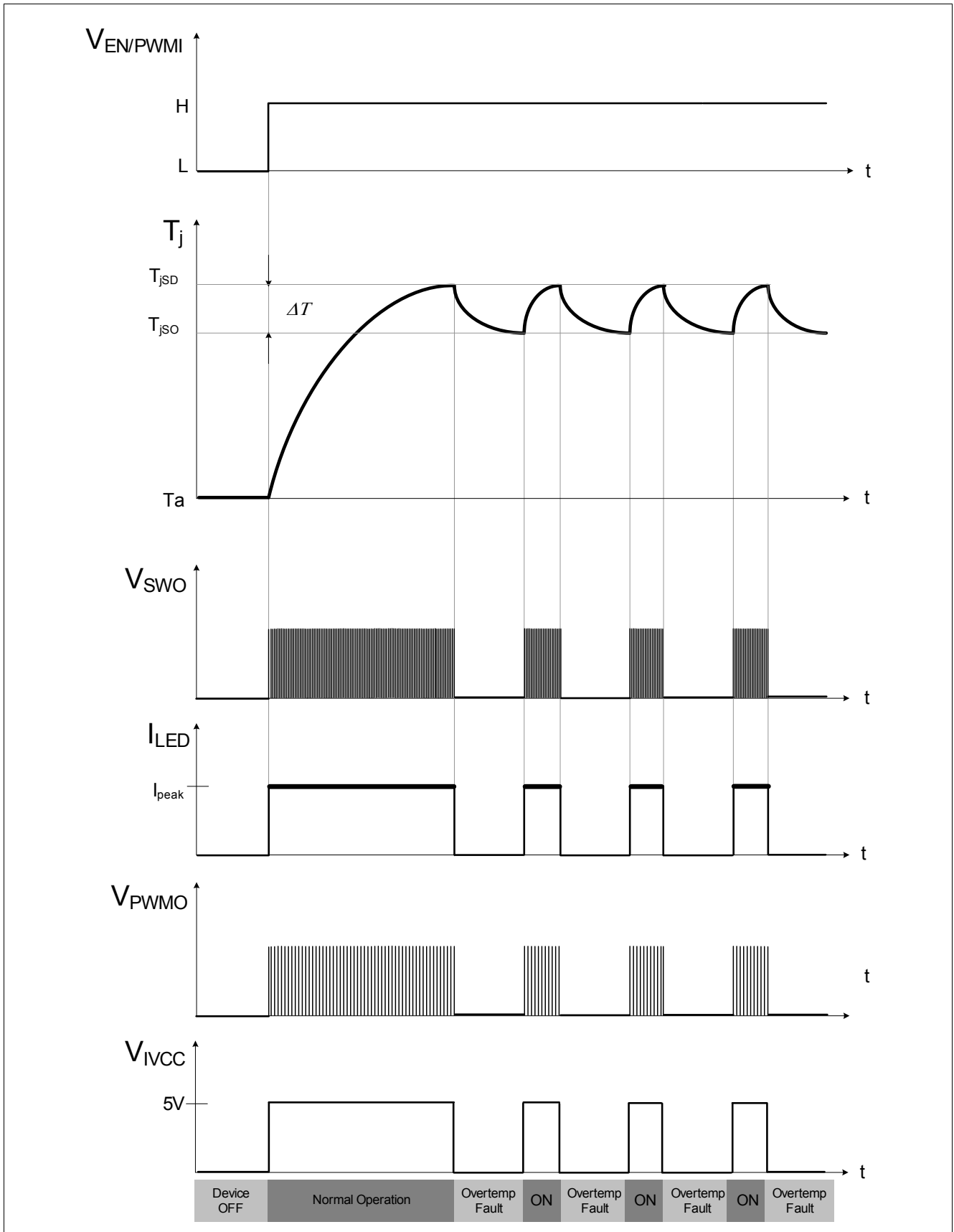

Figure 13 Device overtemperature protection behavior

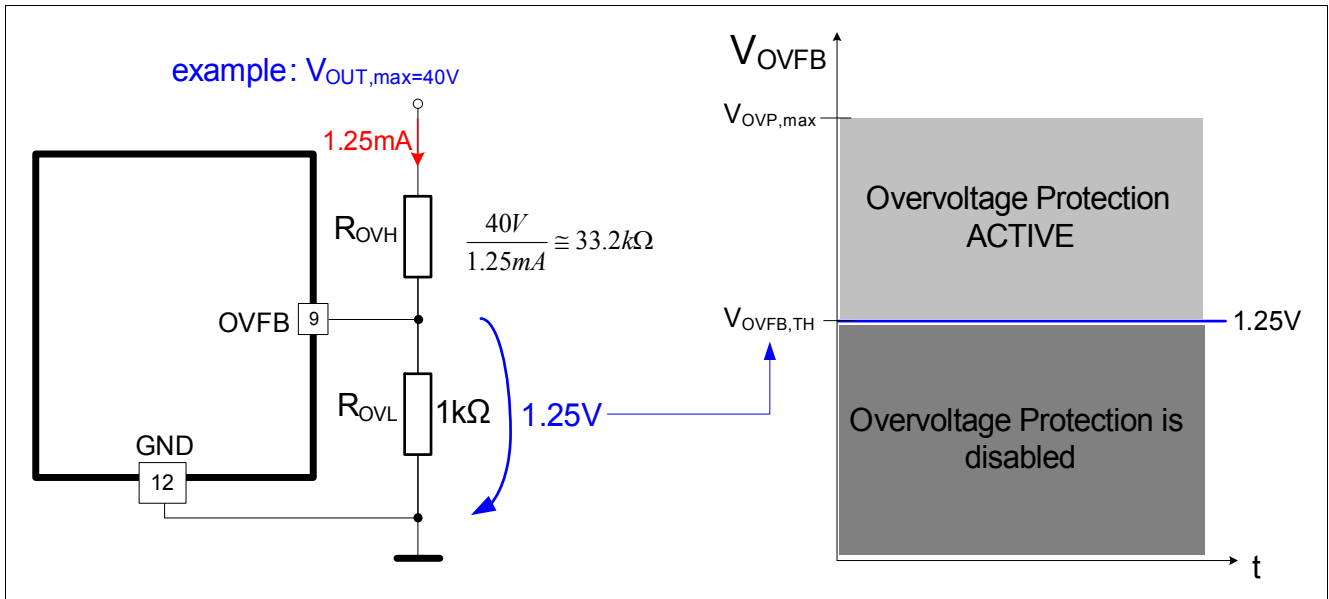

Figure 14 Overtoltage Protection description

Short to GND protection for Highside Return Applications (B2B) from Figure 23

The FBH and FBL pins features a Short to GND detection threshold (V_{FBL,FBH_S2G}). If the potential on those pins is below this threshold the Device stops his operation. This means that the PWMO signal changes to inactive state (LOW potential) and the corresponding p-channel (T_{DIM2}) is switched OFF accordingly and protects the LED chain. For the B2B application some external components are needed to ensure a LOW potential during a short circuit event. D1 and D2 are low power diodes (BAS16-03W) and the resistor R_{lim} (10kOhm) is needed to limit the current through this path. The diode D3 should be a high power diode and is needed to protect the R_{FB} and the FBH and FBL pins in case of an short circuit to GND event. This short circuit detection and protection concept considers potential faults for LED chains (LED Modules) which are separated from the ECU via two wires (at the beginning and at the end of the LED chain). If the short circuit condition disappears, the device will re-start with a soft start.

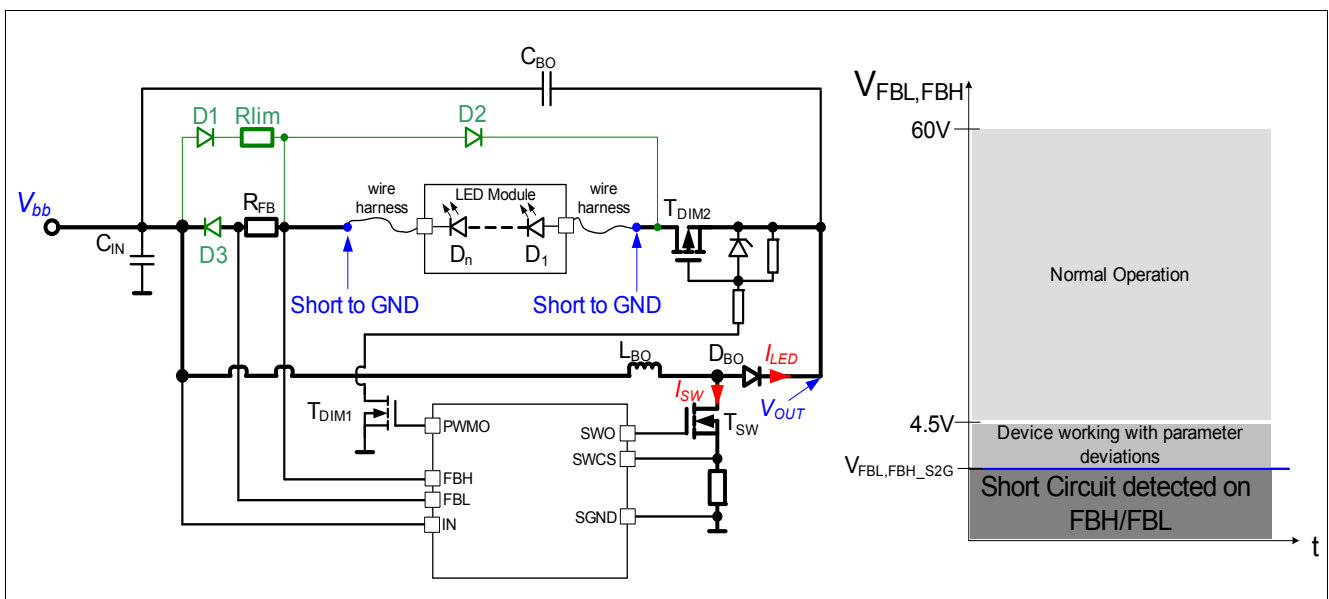

Figure 15 Short Circuit to GND Protection

9.2 Electrical Characteristics

All parameters have been tested at 25°C, unless otherwise specified.

Table 5 EC Protection and Diagnosis

$V_{IN} = 24V$; $T_j = -40\text{ °C}$ to $+125\text{ °C}$, all voltages with respect to ground, positive current flowing into pin; (unless otherwise specified)

Pos.	Parameter	Symbol	Limit Values			Unit	Conditions
			Min.	Typ.	Max.		
Short Circuit Protection							
9.2.1	FBH and FBL Short-Circuit fault sensing common mode range	V_{FBL,FBH_S2G}	1.5	–	2	V	refer to Figure 15 $V_{FBH} = V_{FBL}$ decreasing
Temperature Protection:							
9.2.2	Over Temperature Shutdown	$T_{j,SD}$	160	175	190	°C	¹⁾ refer to Figure 13
9.2.3	Over Temperature Shutdown Hysteresis	$T_{j,SD,HYST}$	–	15	–	°C	¹⁾
Overvoltage Protection:							
9.2.4	Output Over Voltage Feedback Threshold Increasing	$V_{OVFB,TH}$	1.21	1.25	1.29	V	refer to Figure 14
9.2.5	Output Over Voltage Feedback Hysteresis	$V_{OVFB,HYS}$	50	–	150	mV	¹⁾ Output Voltage decreasing
9.2.6	Over Voltage Reaction Time	t_{OVPRR}	2	–	10	µs	Output Voltage decreasing
9.2.7	Over Voltage Feedback Input Current	I_{OVFB}	-1	0.1	1	µA	$V_{OVFB} = 1.25V$
Open Load and Open Feedback Diagnostics							
9.2.8	Open Load/Feedback Threshold	$V_{REF,1,3}$	-100	–	-20	mV	refer to Figure 11 $V_{REF} = V_{FBH} - V_{FBL}$ Open Circuit 1 or 3
9.2.9	Open Feedback Threshold	$V_{REF,2}$	0.5	–	1	V	$V_{REF} = V_{FBH} - V_{FBL}$ Open Circuit 2

1) Specified by design; not subject to production test.

Note: Integrated protection functions are designed to prevent IC destruction under fault conditions described in the data sheet. Fault conditions are considered as “outside” normal operating range. Protection functions are not designed for continuous repetitive operation.

10 Analog Dimming

This pin is influencing the Feedback Voltage Error Amplifier by generating an internal current accordingly to an external reference voltage (V_{SET}). If the analog dimming feature is not needed this pin must be connected to IVCC or external > 1.6V supply. Different application scenarios are described in [Figure 18](#). This pin can also go outside of the ECU for instance if a thermistor is connected on a separated LED Module and the Analog Dimming Input is used to thermally protect the LEDs. For reverse battery protection of this pin an external series resistor should be placed to limit the current.

10.1 Purpose of Analog Dimming:

1) It is difficult for LED manufacturers to deliver LEDs which have the same Brightness, Colorpoint and Forward Voltage Class. Due to this relatively wide spread of the crucial LED parameters customers order LEDs from one or maximum two different colorpoint classes. The LED manufacturer must preselect the LEDs to deliver the requested colorpoint class. Those preselected LEDs are matched in terms of the colorpoint but a variation of the brightness remains. To correct the brightness deviation an analog dimming feature is needed. The mean LED current can be adjusted by applying an external voltage V_{SET} at the SET pin.

2) If the DC/DC application is separated from the LED loads the ECU manufacturers aim is to develop one hardware which should be able to handle different load current conditions (e.g. 80mA to 400mA) to cover different applications. To achieve this average LED current adjustment the analog dimming is a crucial feature.

10.2 Description

Application Example:

Desired LED current = 400mA. For the calculation of the correct Feedback Resistor R_{FB} the following equation can be used: This formula is valid if the analog dimming feature is disabled and $V_{SET} > 1.6V$.

$$I_{LED} = \frac{V_{REF}}{R_{FB}} \quad \rightarrow \quad R_{FB} = \frac{V_{REF}}{I_{LED}} \quad \rightarrow \quad R_{FB} = \frac{0.3V}{400mA} = 750m\Omega$$

A decrease of the average LED current can be achieved by controlling the voltage at the SET pin (V_{SET}) between 0V and 1.6V. The mathematical relation is given in the formula below:

$$I_{LED} = \frac{V_{SET} - 0,1V}{5 * R_{FB}}$$

If V_{SET} is 100mV the LED current is only determined by the internal offset voltages of the comparators. For this example $I_{LED} = 0A$ if $V_{SET} < 100mV$. Refer to the concept drawing in [Figure 17](#).

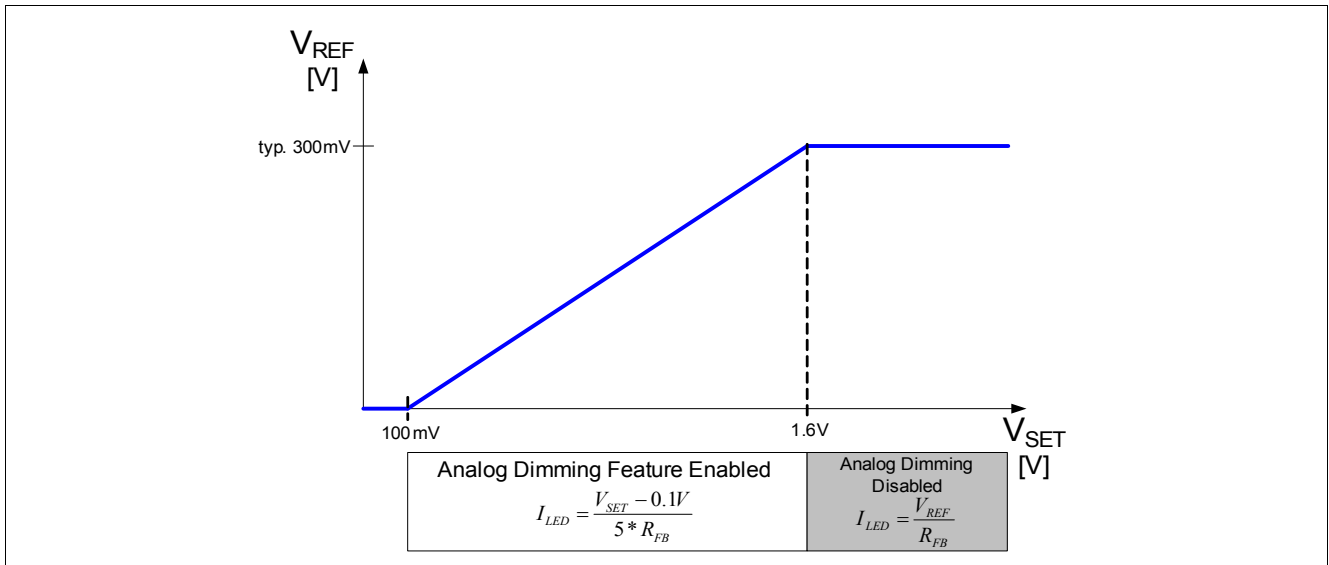

Figure 16 Voltage V_{SET} versus LED current

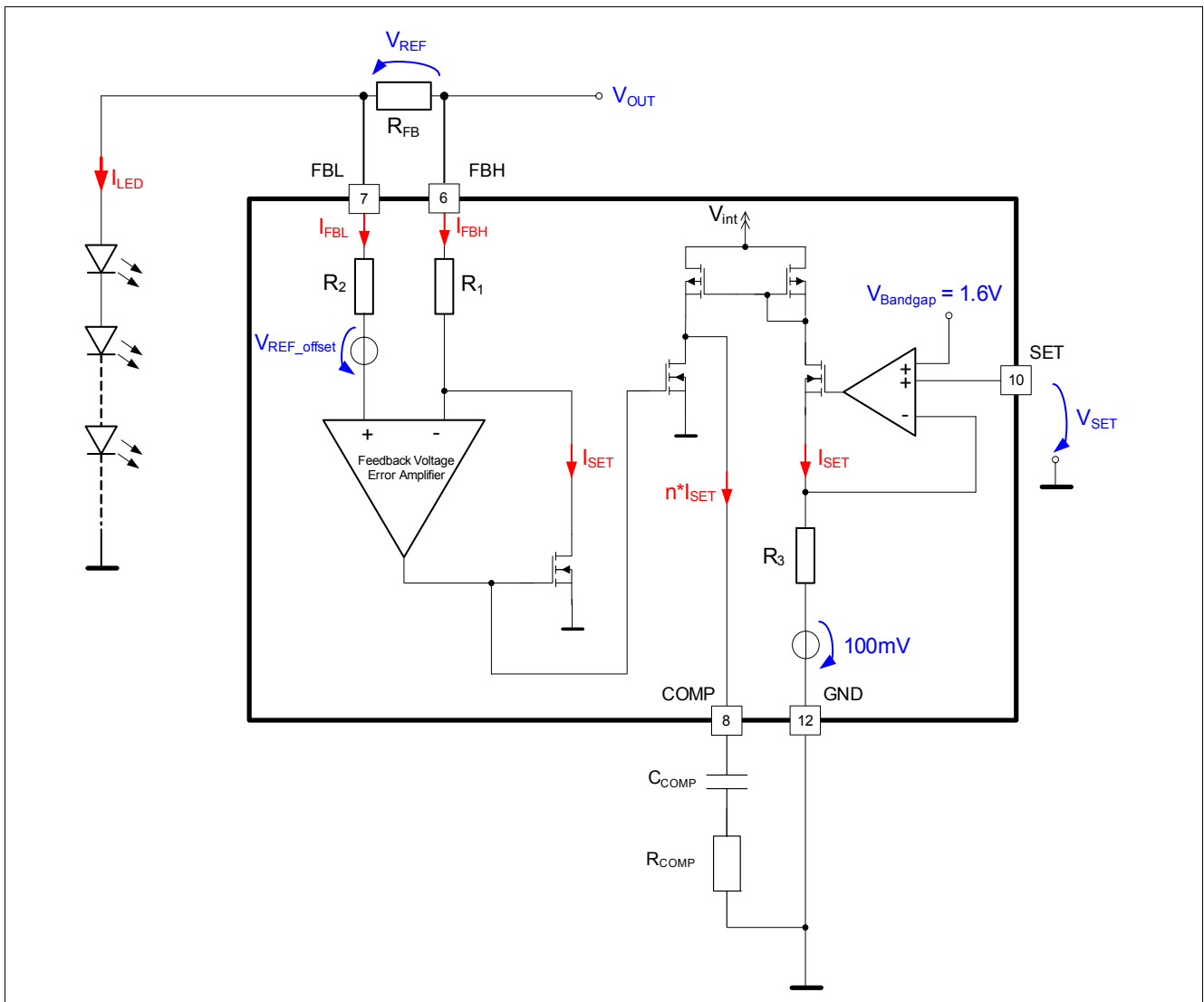

Figure 17 Concept Drawing Analog Dimming

Multi-purpose usage of the Analog dimming feature

- 1)** A μC integrated digital analog converter (DAC) output or a stand alone DAC can be used to supply the SET pin of the ILD1151. The integrated voltage Regulator (V_{IVCC}) can be used to supply the μC or external components if the current consumption does not exceed 25mA.
- 2)** The analog dimming feature is directly connected to the input voltage of the system. In this configuration the LED current is reduced if the input voltage V_{IN} is decreasing. The DC/DC boost converter is changing (increasing) the switching duty cycle if V_{IN} drops to a lower potential. This is causing an increase of the input current consumption. If applications require a decrease of the LED current in respect to V_{IN} variations this setup can be chosen.
- 3)** The usage of an external resistor divider connected between IVCC (integrated 5V regulator output and gate buffer pin) SET and GND can be chosen for systems without μC on board. The concept allows to control the LED current via placing cheap low power resistors. Furthermore a temperature sensitive resistor (Thermistor) to protect the LED loads from thermal destruction can be connected additionally.
- 4)** If the analog dimming feature is not needed the SET pin must be connected directly to $>1.6\text{V}$ potential (e.g. IVCC potential)
- 5)** Instead of an DAC the μC can provide a PWM signal and an external R-C filter is producing a constant voltage for the analog dimming. The voltage level is depending on the PWM frequency (f_{PWM}) and duty cycle (DC) which can be controlled by the μC software after reading the coding resistor placed at the LED module.

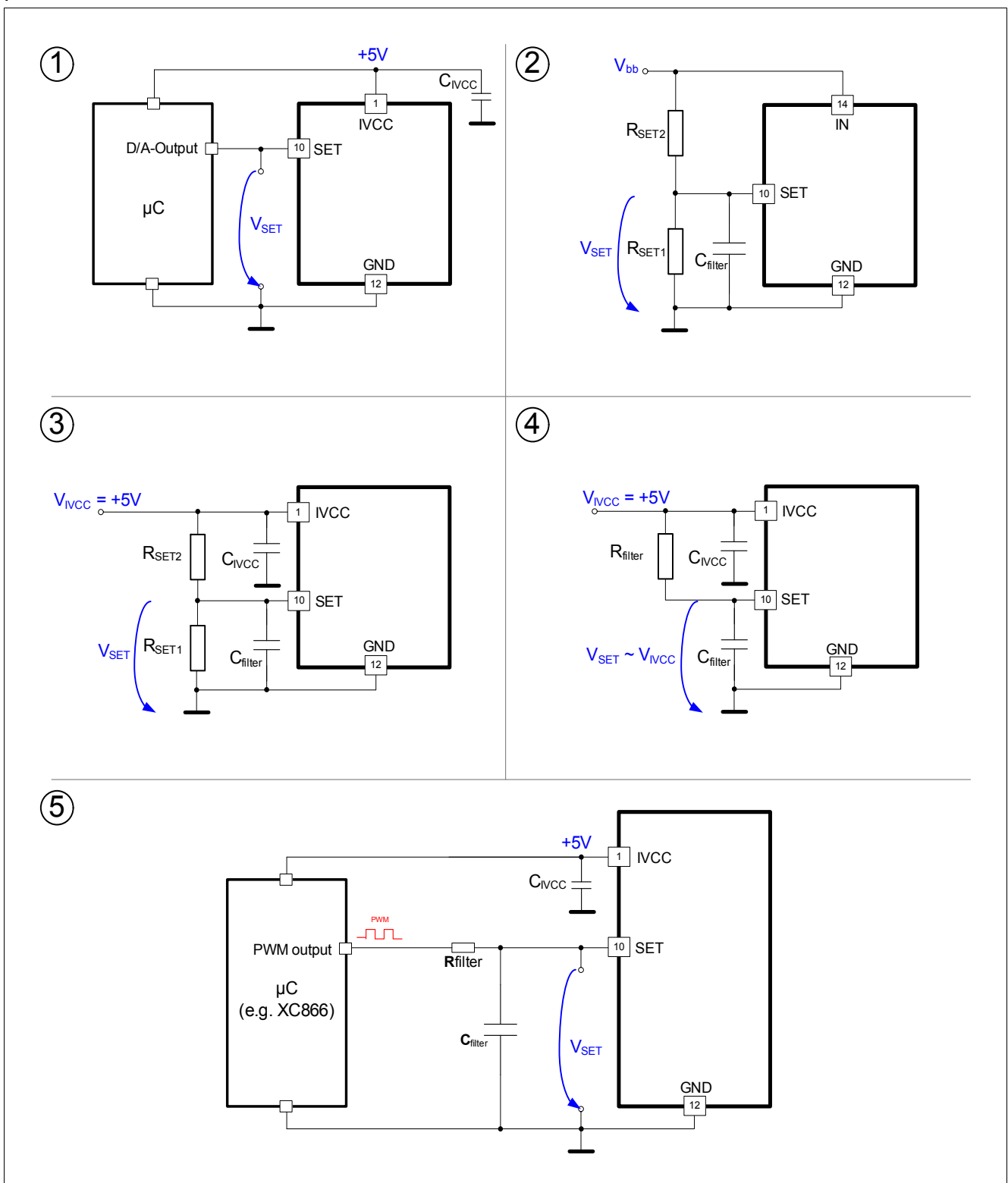

Figure 18 Analog Dimming in various applications

10.3 Electrical Characteristics

All parameters have been tested at 25°C, unless otherwise specified.

Table 6 EC Analog Dimming

$V_{IN} = 24V$; $T_j = -40\text{ °C}$ to $+125\text{ °C}$, all voltages with respect to ground, positive current flowing into pin; (unless otherwise specified)

Pos.	Parameter	Symbol	Limit Values			Unit	Conditions
			Min.	Typ.	Max.		

Analog Dimming Range

10.3.1	SET programming range	V_{SET}	0	–	1.6	V	¹⁾ refer to Figure 16
--------	-----------------------	-----------	---	---	-----	---	--

1) Specified by design; not subject to production test.

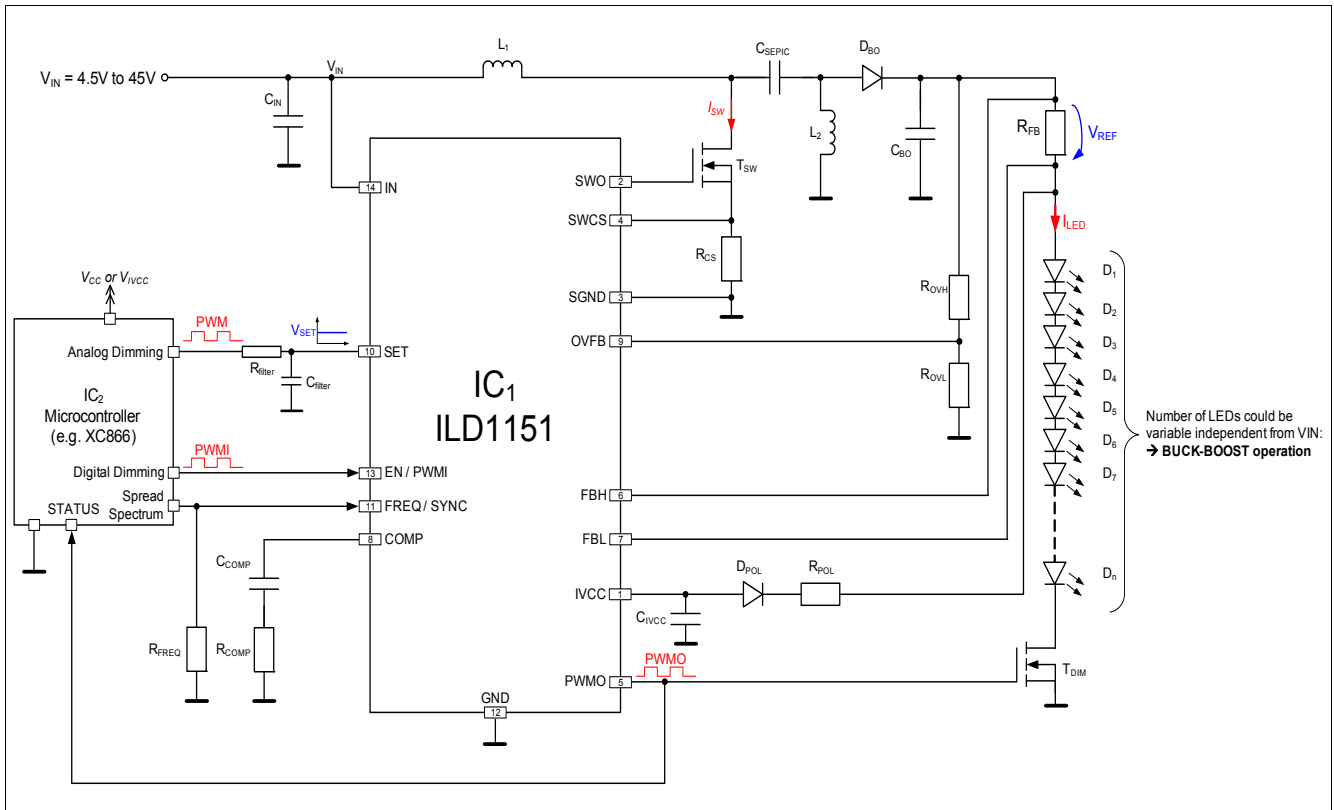

Figure 21 SEPIC Application Circuit (Buck-Boost configuration)

Reference Designator	Value	Manufacturer	Part Number	Type	Quantity
D ₁ - n	White	Osram	LUW H9GP	LED	variable
D _{BO}	Schottky, 3 A, 100 V _R	Vishay	SS3H10	Diode	1
D _{POL}	80V Diode	Infineon	BAS 1603W	Diode	1
C _{SEPIC}	3.3 uF, 20V	EPCOS	X7R, Low ESR	Capacitor	1
C _{IN} , C _{B0}	100 uF, 50V	Panasonic	EEEFK 1H101GP	Capacitor	2
C _{COMP}	10 nF	EPCOS	X7R	Capacitor	1
C _{IVCC}	1uF, 6.3V	EPCOS	X7R	Capacitor	1
IC ₁	--	Infineon	ILD1151	IC	1
IC ₂	--	Infineon	XC866	IC	1
L ₁ , L ₂	47 uH	Coilcraft	MSS1278T-473ML	Inductor	2
	alternativ: 22uH coupled inductor	Coilcraft	MSD1278-223MLD	Inductor	1
R _{COMP} , R _{POL}	10 kΩ, 1%	Panasonic	ERJ3EKF 1002V	Resistor	2
R _{FB}	820 mΩ, 1%	Panasonic	ERJ14BQFR82U	Resistor	1
R _{FREQ}	20 kΩ, 1%	Panasonic	ERJ3EKF 2002V	Resistor	1
R _{OVH}	33.2 kΩ, 1%	Panasonic	ERJ3EKF 3322V	Resistor	1
R _{OVL}	1 kΩ, 1%	Panasonic	ERJ3EKF 1001V	Resistor	1
R _{CS}	50 mΩ, 1%	Panasonic	ERJB1CFR05U	Resistor	1
T _{DIM} , T _{SW}	Dual N-ch enh. (60V, 20A)	Infineon	IPG20N06S4L-26	Transistor	1
	alternativ: 100V N-ch, 35A	Infineon	IPD35N10S3L-26	Transistor	2
	alternativ: 60V N-ch, 2.6A	Infineon	BSP318S	Transistor	2

Figure 22 Bill of Materials for SEPIC Application Circuit

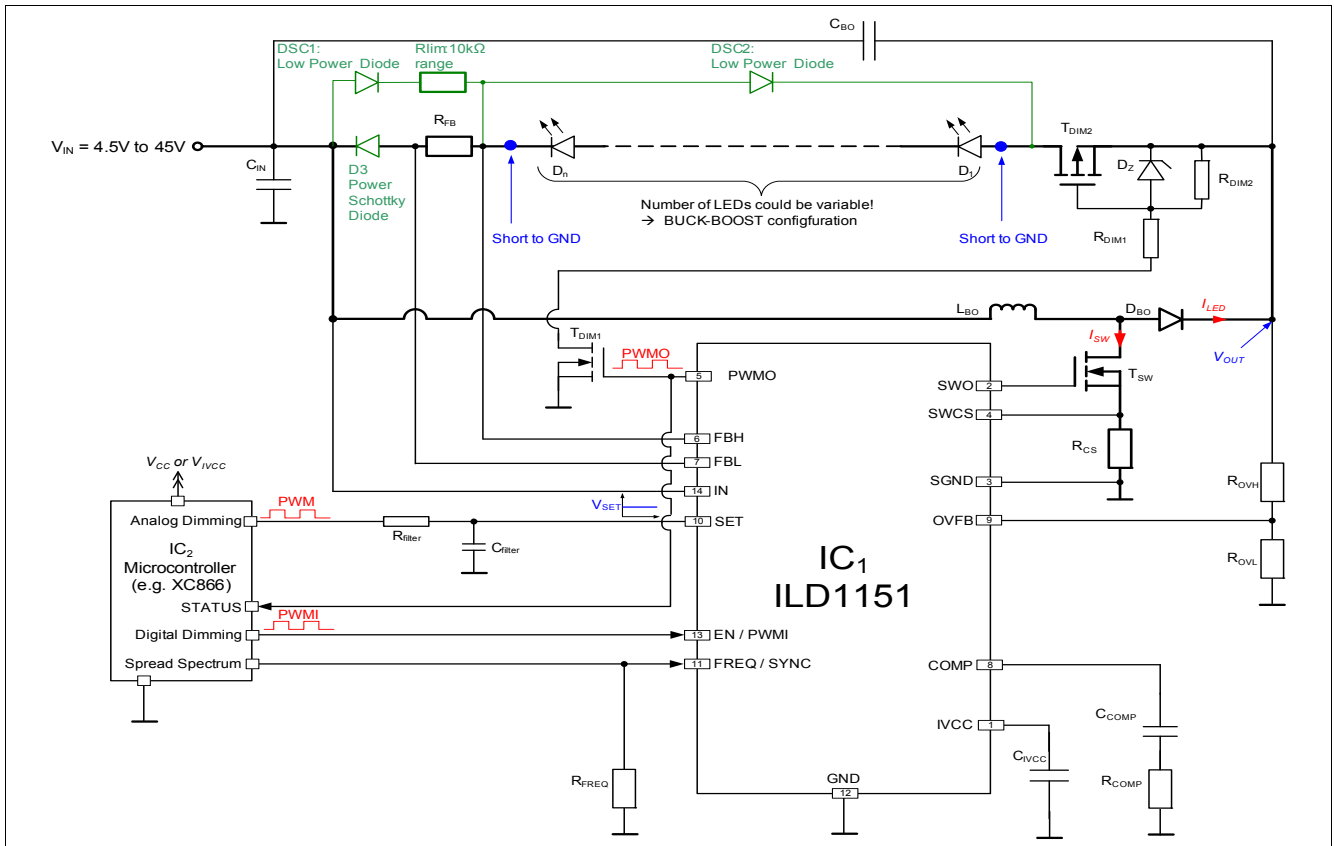
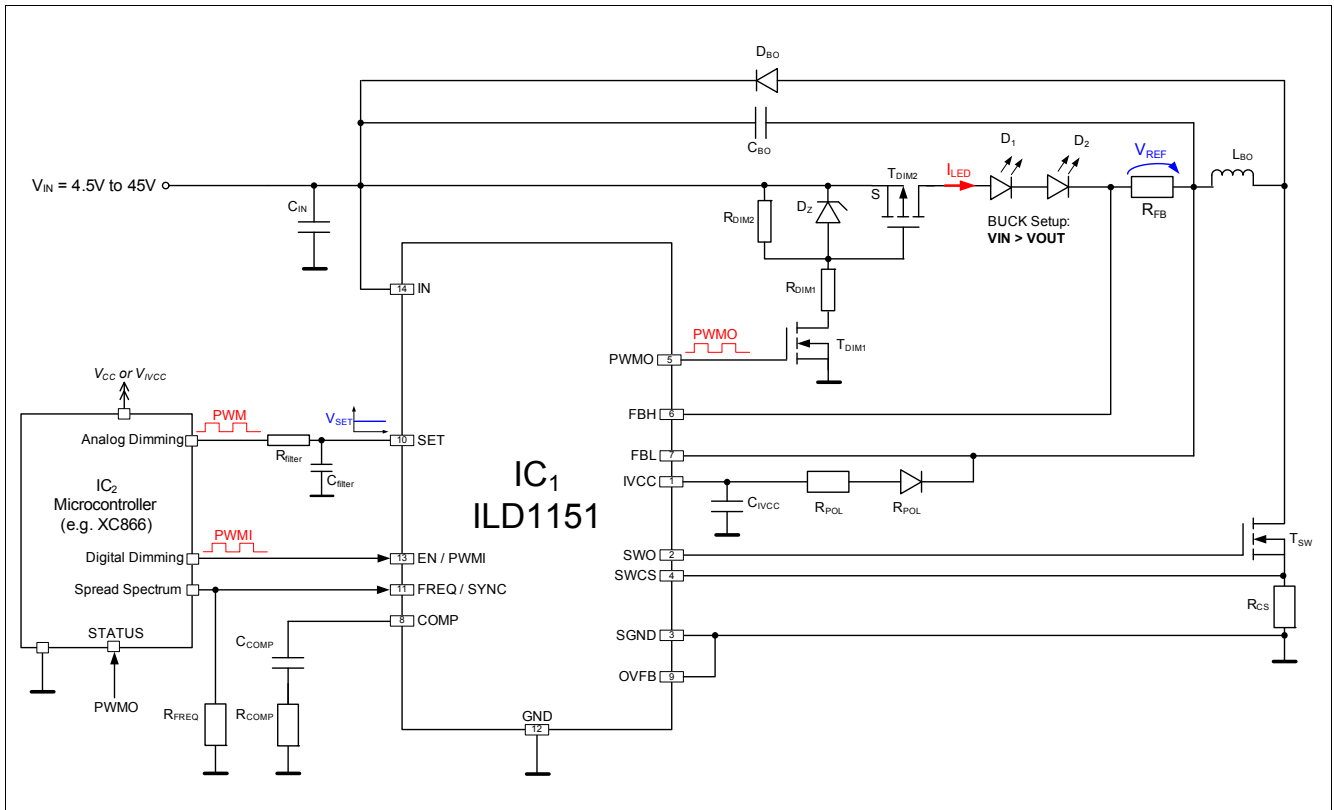

Figure 25 Boost to Battery Application Circuit - B2B + Short Circuit protection (Buck-Boost config.)

Reference Designator	Value	Manufacturer	Part Number	Type	Quantity
D _{1-n}	White	Osram	LUW H9GP	Diode	variable
D _{BO} , D ₃	Schottky, 3 A, 100 V _R	Vishay	SS3H10	Diode	2
D _{SC1} , D _{SC2}	Low Power Diode	Infineon	BAS 16-03W	Diode	2
D _Z	Zener Diode	--	--	Diode	1
C _{BO}	100 uF, 80V	Panasonic	EEVFK1K101Q	Capacitor	1
C _{IN}	100 uF, 50V	Panasonic	EEEFK1H101GP	Capacitor	1
C _{COMP}	10 nF	EPCOS	X7R	Capacitor	1
C _{IVCC}	1 uF, 6.3V	EPCOS	MLCC CCNPZC105KBW X7R	Capacitor	1
IC ₁	--	Infineon	ILD1151	IC	1
IC ₂	--	Infineon	XC866	IC	1
L _{BO}	100 uH	Coilcraft	MSS1278T-104ML_	Inductor	1
R _{COMP} , R _{DIM1} , R _{DIM2} , R _{lim}	10 kΩ, 1%	Panasonic	ERJ3EKF 1002V	Resistor	4
R _{FB}	820 mΩ, 1%	Panasonic	ERJ14BQFR82U	Resistor	1
R _{FREQ}	20 kΩ, 1%	Panasonic	ERJ3EKF 2002V	Resistor	1
R _{OVH}	33.2 kΩ, 1%	Panasonic	ERJP06F5102V	Resistor	1
R _{OVL}	1 kΩ, 1%	Panasonic	ERJ3EKF 1001V	Resistor	1
R _{CS}	50 mΩ, 1%	Panasonic	ERJB1CFR05U	Resistor	1
T _{DIM1} , T _{DIM2}	60V Dual N-ch (3.1A) and P-ch. enh. (2A)	Infineon	BSO615CG	Transistor	1
	alternativ: 100V N-ch (0.37A),	Infineon	BSP 123	Transistor	1
	alternativ: 60V P-ch (1.9A)	Infineon	BSP 171P	Transistor	1
T _{SW}	N-ch, OptiMOS-T2 100V, 35A	Infineon	IPD35N10S3L-26	Transistor	1
	alternativ: 60V N-ch, 30A	Infineon	IPD30N06S4L-23	Transistor	1
	alternativ: 60V N-ch, 2.6A	Infineon	BSP318S	Transistor	1

Figure 26 Bill of Materials for B2B Application Circuit

Figure 27 Buck Application Circuit + Short Circuit protection

Reference Designator	Value	Manufacturer	Part Number	Type	Quantity
D ₁₋₂	White	Osram	LE UW Q9WP	LED	2
D _{BO}	Schottky, 3 A, 100 V _R	Vishay	SS3H10	Diode	1
D _Z	10V	Vishay	Zener Diode	Diode	1
D _{POL}	80V Diode	Infineon	BAS1603W	Diode	1
C _{BO}	4.7 uF, 50V	EPCOS	X7R	Capacitor	1
C _{IN}	100 uF, 50V	Panasonic	EEEFK1H101GP	Capacitor	1
C _{COMP}	47 nF	EPCOS	X7R	Capacitor	1
C _{IVCC}	1 uF, 6.3V	EPCOS	MLCC CCNPZC105KBW X7R	Capacitor	1
IC ₁	--	Infineon	ILD1151	IC	1
IC ₂	--	Infineon	XC866	IC	1
L ₁	22 uH	Coilcraft	MSS1278T	Inductor	1
R _{DIM1+2} , R _{COMP} , R _{POL}	10 kΩ, 1%	Panasonic	ERJ3EKF1002V	Resistor	4
R _{FB}	820 mΩ, 1%	Isabellenhütte	SMS – Power Resistor	Resistor	1
R _{FREQ}	20 kΩ, 1%	Panasonic	ERJ3EKF2002V	Resistor	1
R _{CS}	50 mΩ, 1%	Isabellenhütte	SMS - Power Resistor	Resistor	1
T _{DIM1}	60V, 0.28A	Infineon	BSS138	Transistor	1
T _{DIM2}	-60V, -1.9A	Infineon	BSP171	Transistor	1
T _{SW}	30V, 22A	Infineon	IPB22N03S4L-15	Transistor	1
	alternativ: 60V N-ch, 2.6A	Infineon	BSP318S	Transistor	1

Figure 28 Bill of Materials for Buck Application Circuit

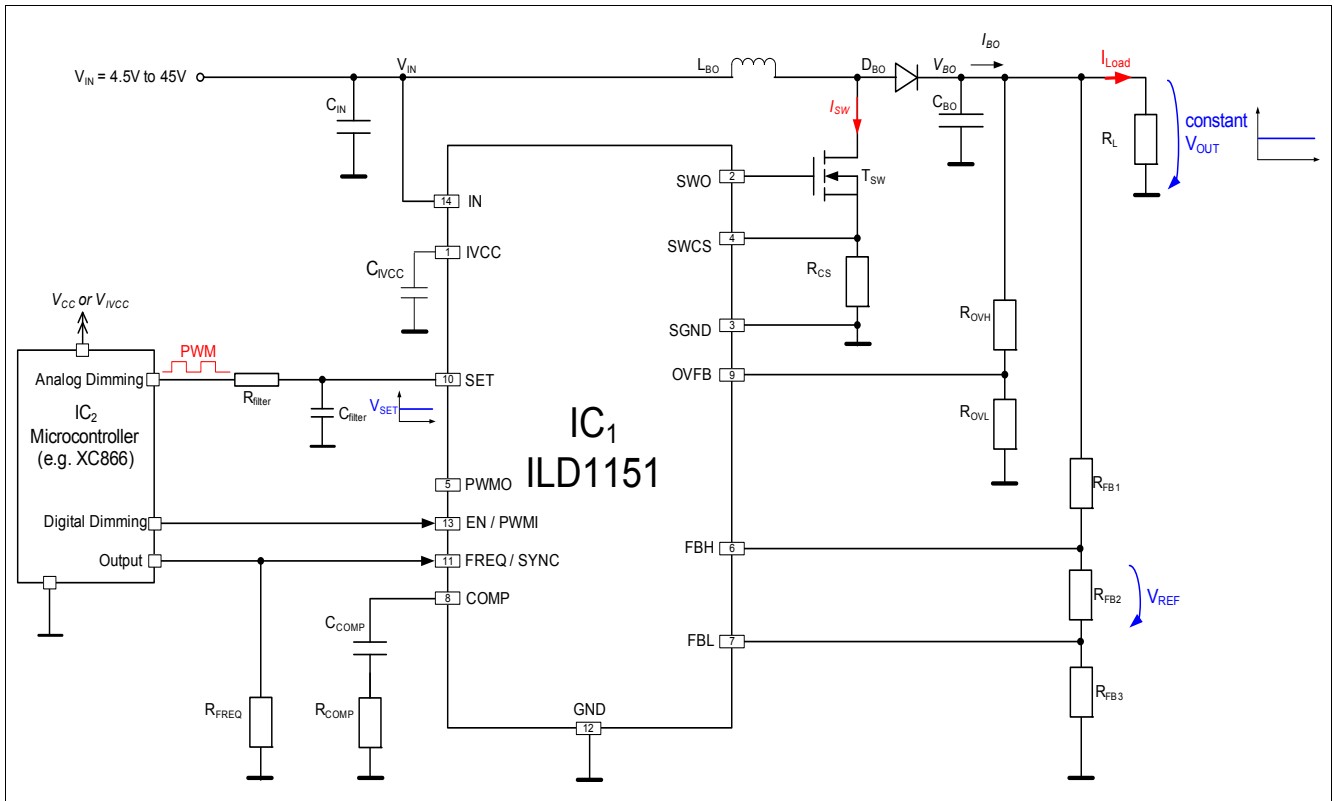

Figure 29 Boost Voltage Application Circuit

Reference Designator	Value	Manufacturer	Part Number	Type	Quantity
D _{BO}	Schottky, 3 A, 100 V _R	Vishay	SS3H10	Diode	1
C _{BO}	100 uF, 80V	Panasonic	EEVFK1K101Q	Capacitor	1
C _{IN}	100 uF, 50V	Panasonic	EEEFK1H101GP	Capacitor	1
C _{COMP}	10 nF	TBD	TBD	Capacitor	1
C _{IVCC}	1 uF, 6.3V	Panasonic	MLCC CCNPZC105KBW X7R	Capacitor	1
IC ₁	--	Infineon	ILD1151	IC	1
IC ₂	--	Infineon	XC886	IC	1
L _{BO}	100 uH	Coilcraft	MSS1278T-104ML_	Inductor	1
R _{COMP}	10 kΩ	TBD	TBD	Resistor	1
R _{FB1} , R _{FB3}	51 kΩ, 1%	Panasonic	ERJ3EKF5102V	Resistor	1
R _{FB2}	1 kΩ, 1%	Panasonic	ERJ3EKF 1001V	Resistor	1
R _{FREQ}	20 kΩ, 1%	Panasonic	ERJ3EKF2002V	Resistor	2
R _{OVH}	51 kΩ, 1%	Panasonic	ERJP06F5102V	Resistor	1
R _{OVL}	1 kΩ, 1%	Panasonic	ERJ3EKF 1001V	Resistor	1
R _{CS}	50 mΩ, 1%	Panasonic	ERJB 1CFR05U	Resistor	1
T _{SW}	N-ch, 75 V, 65 mΩ	Infineon	IPD22N08S2L-50	Transistor	1

Figure 30 Bill of Materials for Boost Voltage Application Circuit

Note: This is a very simplified example of an application circuit. The function must be verified in the real application.

11.1 Further Application Information

- For further information you may contact <http://www.infineon.com/>
- Application Note: ILD1150 / ILD1151 DC-DC Multitopology Controller IC for Industrial Applications
“Dimensioning and Stability Guideline - Theory and Practice”

12 Package Outlines

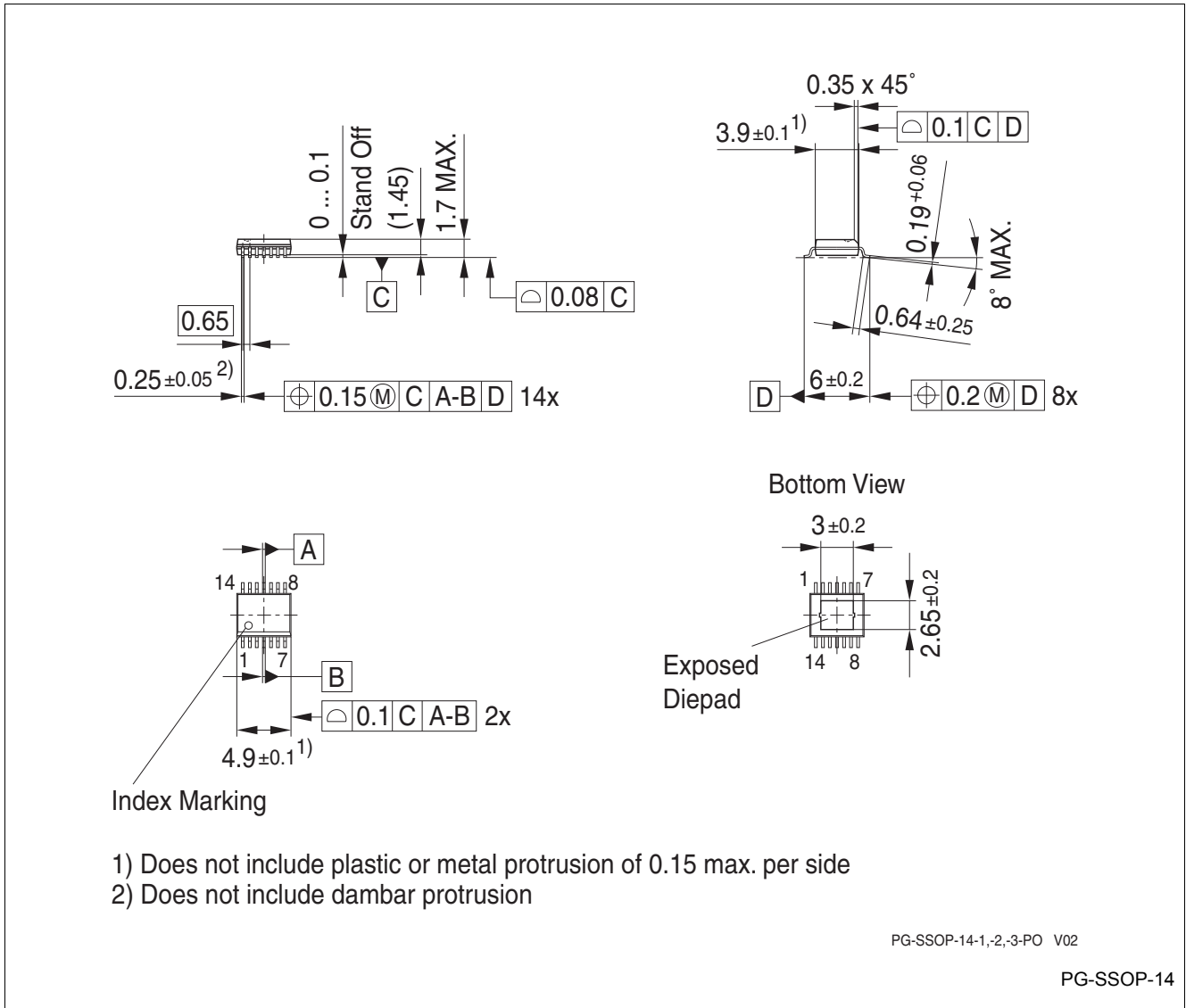

Figure 31 PG-SSOP-14

Green Product (RoHS compliant)

To meet the world-wide customer requirements for environmentally friendly products and to be compliant with government regulations the device is available as a green product. Green products are RoHS-Compliant (i.e. Pb-free finish on leads and suitable for Pb-free soldering according to IPC/JEDEC J-STD-020).

For further package information, please visit our website:
<http://www.infineon.com/packages>.

Dimensions in mm

13 Revision History

Revision	Date	Changes
1.0	2011-02-10	Initial Datasheet
1.1	2012-04-11	Page 3: RoHS Logo update Page 3: Topology update Application Information chapter update

Edition 2012-04-11

**Published by
Infineon Technologies AG
81726 Munich, Germany**

**© 2012 Infineon Technologies AG
All Rights Reserved.**

Legal Disclaimer

The information given in this document shall in no event be regarded as a guarantee of conditions or characteristics. With respect to any examples or hints given herein, any typical values stated herein and/or any information regarding the application of the device, Infineon Technologies hereby disclaims any and all warranties and liabilities of any kind, including without limitation, warranties of non-infringement of intellectual property rights of any third party.

Information

For further information on technology, delivery terms and conditions and prices, please contact the nearest Infineon Technologies Office (www.infineon.com).

Warnings

Due to technical requirements, components may contain dangerous substances. For information on the types in question, please contact the nearest Infineon Technologies Office.

Infineon Technologies components may be used in life-support devices or systems only with the express written approval of Infineon Technologies, if a failure of such components can reasonably be expected to cause the failure of that life-support device or system or to affect the safety or effectiveness of that device or system. Life support devices or systems are intended to be implanted in the human body or to support and/or maintain and sustain and/or protect human life. If they fail, it is reasonable to assume that the health of the user or other persons may be endangered.