

# CIPOS™ Nano

## IM111-X6Q1B

### Description

IM111-X6Q1B is an H-bridge integrated power module (IPM) designed for advanced appliance motor drive applications. This advanced low profile IPM offers a combination of Infineon's low  $R_{DS(on)}$  CoolMOS™ technology and the industry benchmark high voltage, rugged driver in a small 12x10mm QFN package.

### Features

- Integrated gate drivers and bootstrap functionality
- Overcurrent protection & fault reporting
- Low  $0.28\Omega$   $R_{DS(on)}$ , 600V CoolMOS™
- Under-voltage lockout for both channels
- Shoot through protection
- Matched propagation delay for all channels
- Optimized  $dv/dt$  for loss and EMI trade offs
- Advanced input filter
- 3.3V input logic compatible
- Motor power range 80-200W
- $1500V_{RMS}$  min isolation

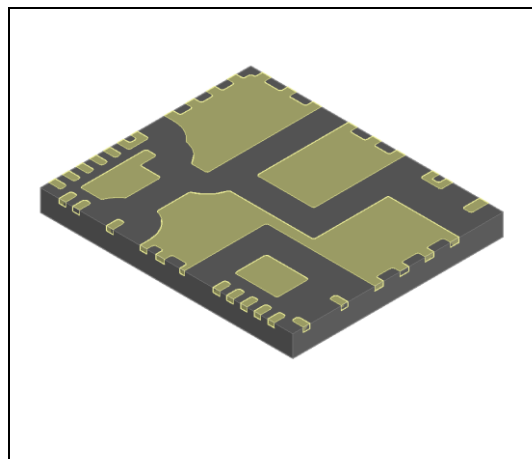

### Potential Applications

- Linear refrigerator compressors
- High efficiency single-phase motor drives
- DC-AC inverters

### Product Validation

Qualified for industrial applications according to the relevant tests of JEDEC47/20/22.

**Table 1** Part Ordering Table

Base Part Number	Package Type	Standard Pack		Orderable Part Number
		Form	Quantity	
IM111-X6Q1B	QFN 12x10mm	Tape and Reel	2000	IM111-X6Q1BAUMA1

## Table of contents

Description.....	1
Features.....	1
Potential Applications.....	1
Product Validation.....	1
Table of contents.....	2
<b>1 Internal Electrical Schematic .....</b>	<b>3</b>
<b>2 Pin Configuration.....</b>	<b>4</b>
2.1 Pin Assignment.....	4
2.2 Pin Descriptions.....	5
<b>3 Absolute Maximum Rating .....</b>	<b>6</b>
3.1 Module .....	6
3.2 Inverter .....	6
3.3 Control.....	6
<b>4 Thermal Characteristics .....</b>	<b>7</b>
<b>5 Recommended Operating Conditions.....</b>	<b>8</b>
<b>6 Static Parameters .....</b>	<b>9</b>
6.1 Inverter .....	9
6.2 Control.....	9
<b>7 Dynamic Parameters .....</b>	<b>10</b>
7.1 Inverter .....	10
7.2 Control.....	10
<b>8 Thermistor Characteristics .....</b>	<b>11</b>
<b>9 Qualification Information .....</b>	<b>12</b>
<b>10 Diagrams &amp; Tables .....</b>	<b>13</b>
10.1 Input-Output Logic Table.....	13
10.2 Switching Time Definitions .....	13
<b>11 Application Guide .....</b>	<b>14</b>
11.1 Typical Application Schematic .....	14
11.2 Performance Charts .....	14
11.3 -Vs Immunity.....	15
<b>12 Package Outline .....</b>	<b>16</b>
<b>Revision History .....</b>	<b>18</b>

# 1 Internal Electrical Schematic

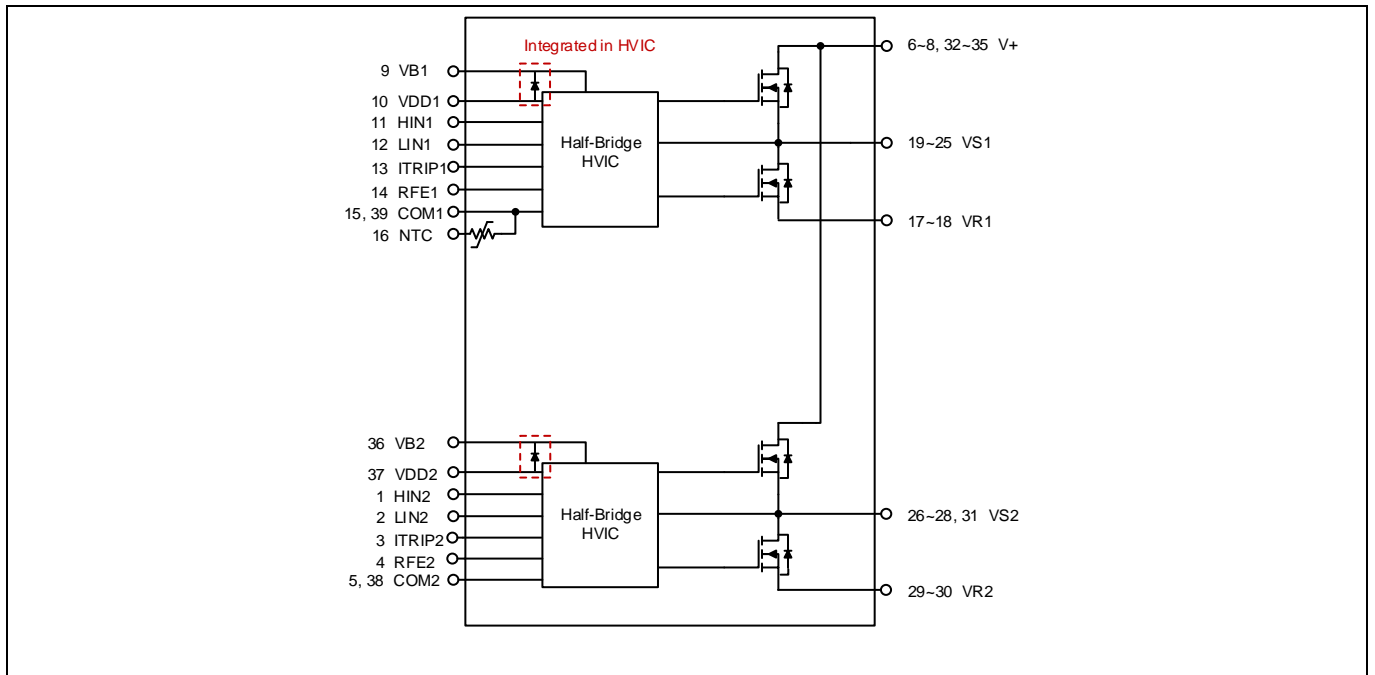

**Figure 1** Internal electrical schematic.

## 2 Pin Configuration

### 2.1 Pin Assignment

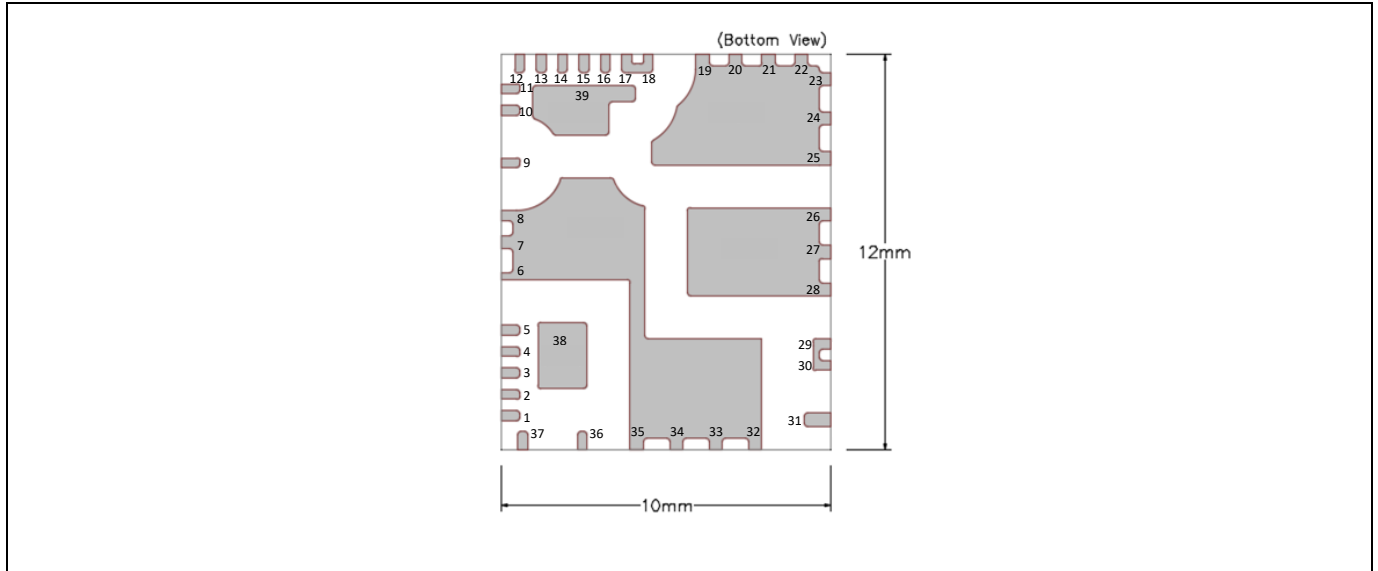

Figure 2 Module pinout

Table 2 Pin Assignment

Pin	Name	Description
1	HIN <sub>2</sub>	Logic Input for High Side Gate Driver (Active High)
2	LIN <sub>2</sub>	Logic Input for Low Side Gate Driver (Active High)
3	I <sub>TRIP2</sub>	Over Current Protection
4	RFE <sub>2</sub>	Fault Clear, Fault Reporting & Enable
5	COM <sub>2</sub>	Logic Ground
6-8	V+	DC Bus Voltage Positive
9	V <sub>B1</sub>	High Side Floating Supply (Bootstrap Cap Connection +)
10	V <sub>DD1</sub>	Low Side Control Supply
11	HIN <sub>1</sub>	Logic Input for High Side Gate Driver (Active High)
12	LIN <sub>1</sub>	Logic Input for Low Side Gate Driver (Active High)
13	I <sub>TRIP1</sub>	Over Current Protection
14	RFE <sub>1</sub>	Fault Clear, Fault Reporting & Enable
15	COM <sub>1</sub>	Logic Ground
16	NTC	Negative Temperature Coefficient Thermistor
17-18	V <sub>R1</sub>	Low Side Source
19-25	V <sub>S1</sub>	Phase Output
26-28	V <sub>S2</sub>	Phase Output
29-30	V <sub>R2</sub>	Low Side Source
31	V <sub>S2</sub>	Phase Output (Bootstrap Cap Connection -)
32-35	V+	DC Bus Voltage Positive
36	V <sub>B2</sub>	High Side Floating Supply (Bootstrap Cap Connection +)
37	V <sub>DD2</sub>	Low Side Control Supply
38	COM <sub>2</sub>	Logic Ground
39	COM <sub>1</sub>	Logic Ground

## 2.2 Pin Descriptions

### LIN and HIN (Low side and high side control pins)

These pins are positive logic and they are responsible for the control of the integrated CoolMOS. The Schmitt-trigger input thresholds of them are such to guarantee LSTTL and CMOS compatibility down to 3.3V controller outputs. Pull-down resistor of about 800kΩ is internally provided to pre-bias inputs during supply start-up and an ESD diode is provided for pin protection purposes. Input Schmitt-trigger and noise filter provide beneficial noise rejection to short input pulses.

The noise filter suppresses control pulses which are below the filter time  $t_{FILIN}$ . The filter acts according to Figure 4.

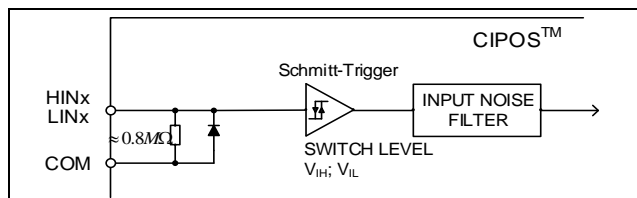

Figure 3 Input pin structure

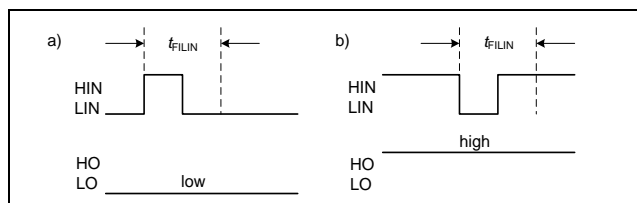

Figure 4 Input filter timing diagram

The integrated gate drive provides additionally a shoot through prevention capability which avoids the simultaneous on-state of the high-side and low-side switch of the same inverter phase. A minimum deadtime insertion of typically 300ns is also provided by driver IC, in order to reduce cross-conduction of the external power switches.

### V<sub>DD</sub>, COM (Low side control supply and reference)

V<sub>DD</sub> is the control supply and it provides power both to input logic and to output power stage. Input logic is referenced to COM ground.

The under-voltage circuit enables the device to operate at power on when a supply voltage of at least a typical voltage of V<sub>DDUV+</sub> = 8.9V is present.

The IC shuts down all the gate drivers power outputs, when the V<sub>DD</sub> supply voltage is below V<sub>DDUV-</sub>.

= 7.7V. This prevents the external power switches from critically low gate voltage levels during on-state and therefore from excessive power dissipation.

### V<sub>B</sub> and V<sub>S</sub> (High side supplies)

V<sub>B</sub> to V<sub>S</sub> is the high side supply voltage. The high side circuit can float with respect to COM following the external high side power device source voltage.

Due to the low power consumption, the floating driver stage is supplied by integrated bootstrap circuit.

The under-voltage detection operates with a rising supply threshold of typical V<sub>BSUV+</sub> = 8.9V and a falling threshold of V<sub>BSUV-</sub> = 7.7V.

V<sub>S</sub> provide a high robustness against negative voltage in respect of COM. This ensures very stable designs even under rough conditions.

### V<sub>R</sub> (Low side source)

The low side source is available for current measurements of each phase leg. It is recommended to keep the connection to pin COM as short as possible in order to avoid unnecessary inductive voltage drops.

### V<sub>S</sub> (High side source and low side drain)

This pin is motor input pin.

### V+ (Positive bus input voltage)

The high side CoolMOS devices are connected to the bus voltage. It is noted that the bus voltage does not exceed 450V.

### I<sub>TRIP</sub> (Over current protection)

Analog input for over-current shutdown. When active, I<sub>TRIP</sub> shuts down outputs and activates RFE low.

### RFE (Fault clear, fault reporting and enable)

Integrated fault reporting function, fault clear timer and external enable pin. This pin has negative logic and an open-drain output.

### 3 Absolute Maximum Ratings

#### 3.1 Module

Table 3

Parameter	Symbol	Condition		Units
Storage temperature	$T_{STG}$		-40 ~ 150	°C
Operating case temperature	$T_C$		-40 ~ 125	°C
Operating junction temperature	$T_J$		-40 ~ 150	°C
Isolation voltage <sup>1</sup>	$V_{ISO}$	1min, RMS, f = 60Hz	1500	V

1. Characterized, not tested at production

#### 3.2 Inverter

Table 4

Parameter	Symbol	Condition		Units
Max. blocking voltage	$V_{DSS}/V_{RRM}$		600	V
Output current based on $R_{TH(J-C)}$ <sup>1</sup>	$I_O$	$T_C = 25^\circ\text{C}$ , DC	12	A
Peak output current	$I_{OP}$	$T_C = 25^\circ\text{C}$ , pulsed current	20	A
Output current based on $R_{TH(J-A)}$	$I_{OA}$	$T_A = 25^\circ\text{C}$ , DC	2	A
Peak power dissipation per MOSFET	P	$T_C = 25^\circ\text{C}$	175	W

1. Limited by wire bonding current capability inside the package

#### 3.3 Control

Table 5

Parameter	Symbol	Condition		Units
Low side control supply voltage	$V_{DD}$		-0.3 ~ 20	V
Input voltage LIN, HIN	$V_{IN}$		-0.3 ~ $V_{DD}$	V
High side floating supply voltage ( $V_B$ reference to $V_S$ )	$V_{BS}$		-0.3 ~ 20	V

## 4 Thermal Characteristics

Table 6

Parameter	Symbol	Conditions	Min.	Typ.	Max.	Units
Single MOSFET thermal resistance, junction-case (bottom)	$R_{TH(J-C)B}$	Measures either high side or low side device	-	0.6	-	°C/W
Thermal resistance, junction-ambient <sup>(1)</sup>	$R_{TH(J-A)}$		-	12	-	°C/W

(1) The junction to ambient thermal resistance is simulated based on standard JESD51-5/7 using a FR4 2s2p board with device mounted and power evenly distributed to four power MOSFETs.

## 5 Recommended Operating Conditions

**Table 7**

Parameter	Symbol	Min.	Typ.	Max.	Units
Positive DC bus input voltage	V+	-	-	450	V
Low side control supply voltage	V <sub>DD</sub>	13.5	-	16.5	V
High side floating supply voltage	V <sub>BS</sub>	12.5	-	17.5	V
Input voltage	V <sub>IN</sub>	0	-	5	V
PWM carrier frequency	F <sub>PWM</sub>	-	6	-	kHz
External dead time between HIN & LIN	DT	1	-	-	μs
Voltage between COM and V <sub>R</sub>	V <sub>COMR</sub>	-5	-	5	V
Minimum input pulse width	PW <sub>IN(ON)</sub> , PW <sub>IN(OFF)</sub>	0.5	-	-	μs

## 6 Static Parameters

### 6.1 Inverter

$(V_{DD-COM}) = (V_B - V_S) = 15\text{ V}$ .  $T_C = 25^\circ\text{C}$  unless otherwise specified.

**Table 8**

Parameter	Symbol	Conditions	Min.	Typ.	Max.	Units
Drain to Source ON Resistance	$R_{DS(on)}$	$I_D = 0.5\text{A}$	-	0.28	0.31	$\Omega$
		$I_D = 0.5\text{A}, T_J = 150^\circ\text{C}$	-	0.59	-	$\Omega$
Drain source leakage current	$I_{DSS}$	$V_{IN} = 0\text{V}, V_+ = 600\text{V}$	-	20	-	$\mu\text{A}$
		$V_{IN} = 0\text{V}, V_+ = 600\text{V}, T_J = 150^\circ\text{C}$	-	40	-	$\mu\text{A}$
Diode forward voltage	$V_F$	$I_F = 0.5\text{A}$	-	0.69	-	V
		$I_F = 0.5\text{A}, T_J = 150^\circ\text{C}$	-	0.48	-	V

### 6.2 Control

$(V_{DD-COM}) = (V_B - V_S) = 15\text{ V}$ .  $T_C = 25^\circ\text{C}$  unless otherwise specified. The  $V_{IN}$  and  $I_{IN}$  are referenced to COM and are applicable to all six channels. The  $V_{DDUV}$  is referenced to COM. The  $V_{BSUV}$  is referenced to  $V_S$ .

**Table 9**

Parameter	Symbol	Min.	Typ.	Max.	Units
Logic "1" input voltage (LIN, HIN)	$V_{IN,TH+}$	2.2	-	-	V
Logic "0" input voltage (LIN, HIN)	$V_{IN,TH-}$	-	-	0.8	V
RFE positive going threshold	$V_{RFE+}$	-	-	2.5	V
RFE negative going threshold	$V_{RFE-}$	0.8	-	-	V
$V_{DD}/V_{BS}$ supply undervoltage, positive going threshold	$V_{DD,UV+}, V_{BS,UV+}$	8	8.9	9.8	V
$V_{DD}/V_{BS}$ supply undervoltage, negative going threshold	$V_{DD,UV-}, V_{BS,UV-}$	6.9	7.7	8.5	V
$V_{DD}/V_{BS}$ supply undervoltage lock-out hysteresis	$V_{DDUVH}, V_{BSUVH}$	-	1.2	-	V
Quiescent $V_{BS}$ supply current	$I_{QBS}$	-	45	70	$\mu\text{A}$
Quiescent $V_{DD}$ supply current	$I_{QCC}$	1.0	1.7	3.0	mA
Input bias current $V_{IN}=4\text{V}$ for LIN, HIN	$I_{IN+}$	-	5	20	$\mu\text{A}$
Input bias current $V_{IN}=0\text{V}$ for LIN, HIN	$I_{IN-}$	-	-	2	$\mu\text{A}$
Input bias current $V_{IN} = 4\text{V}$ for RFE	$I_{IN,RFE+}$	-	0	1	$\mu\text{A}$
Input bias current $V_{IN} = 4\text{V}$ for $I_{TRIP}$	$I_{TRIP+}$	-	5	20	$\mu\text{A}$
$I_{TRIP}$ positive going threshold	$V_{IT,TH+}$	0.475	0.500	0.525	V
$I_{TRIP}$ negative going threshold	$V_{IT,TH-}$	-	0.43	-	V
$I_{TRIP}$ input hysteresis	$V_{IT,HYS}$	-	0.07	-	V
Bootstrap resistance	$R_{BS}$	-	200	-	$\Omega$
RFE low on resistance	$R_{RFE}$	-	50	100	$\Omega$

## 7 Dynamic Parameters

### 7.1 Inverter

( $V_{DD-COM}$ ) = ( $V_B - V_S$ ) = 15 V.  $T_C = 25^\circ\text{C}$  unless otherwise specified.

**Table 10**

Parameter	Symbol	Conditions	Min.	Typ.	Max.	Units
Input to output turn-on propagation delay	$T_{ON}$	$I_D = 0.5\text{A}, V_+ = 300\text{V}$	-	0.88	-	$\mu\text{s}$
Turn-on rise time	$T_R$		-	37	-	ns
Turn-on switching time	$T_{C(on)}$		-	167	-	ns
Input to output turn-off propagation delay	$T_{OFF}$	$I_D = 0.5\text{A}, V_+ = 300\text{V}$	-	0.92	-	$\mu\text{s}$
Turn-off fall time	$T_F$		-	186	-	ns
Turn-off switching time	$T_{C(off)}$		-	192	-	ns
RFE low to six switch turn-off propagation delay	$T_{EN}$	$V_{IN} = 0$ or $V_{IN} = 5\text{V}, V_{EN} = 5\text{V}$	-	0.52	-	$\mu\text{s}$
$I_{TRIP}$ to six switch turn-off propagation delay	$T_{ITRIP}$		-	900	-	ns
Turn-on switching energy	$E_{ON}$	$I_D = 0.5\text{A}, V_+ = 300\text{V}, V_{DD} = 15\text{V}, L = 9\text{mH}$	-	54	-	$\mu\text{J}$
Turn-off switching energy	$E_{OFF}$		-	11	-	
Diode reverse recovery energy	$E_{REC}$		-	7	-	
Diode reverse recovery time	$T_{RR}$		-	121	-	ns
Turn-on switching energy	$E_{ON}$	$I_D = 0.5\text{A}, V_+ = 300\text{V}, V_{DD} = 15\text{V}, L = 9\text{mH}, T_J = 150^\circ\text{C}$	-	126	-	$\mu\text{J}$
Turn-off switching energy	$E_{OFF}$		-	12	-	
Diode reverse recovery energy	$E_{REC}$		-	10	-	
Diode reverse recovery time	$T_{RR}$		-	203	-	ns

### 7.2 Control

( $V_{DD-COM}$ ) = ( $V_B - V_S$ ) = 15V.  $T_C = 25^\circ\text{C}$  unless otherwise specified.

**Table 11**

Parameter	Symbol	Conditions	Min.	Typ.	Max.	Units
Input filter time ( $H_{IN}, L_{IN}, I_{TRIP}$ )	$T_{FIL,IN}$	$V_{IN} = 0$ or $V_{IN} = 5\text{V}$	-	300	-	ns
Input filter time (RFE)	$T_{FIL,EN}$	$V_{RFE} = 0$ or $V_{RFE} = 5\text{V}$	-	500	-	ns
ITRIP to Fault propagation delay	$T_{FLT}$	$V_{IN} = 0$ or $V_{IN} = 5\text{V}, V_{ITRIP} = 5\text{V}$	-	660	-	ns
Internal injected dead time	$T_{DT,GD}$	$V_{IN} = 0$ or $V_{IN} = 5\text{V}$	-	300	-	ns
Matching propagation delay time (on and off) for same phase high-side and low-side	$M_T$	External dead time > $1\mu\text{s}$	-	-	50	ns

## 8 Thermistor Characteristics

Table 12

Parameter	Symbol	Conditions	Min.	Typ.	Max.	Units
Resistance	$R_{25}$	$T_C = 25^\circ\text{C}$ , $\pm 5\%$ tolerance	44.65	47	49.35	k $\Omega$
Resistance	$R_{125}$	$T_C = 125^\circ\text{C}$	1.27	1.39	1.51	k $\Omega$
B-constant (25/100)	B	$\pm 1\%$ tolerance	-	4006	-	K
Temperature Range			-20	-	150	$^\circ\text{C}$

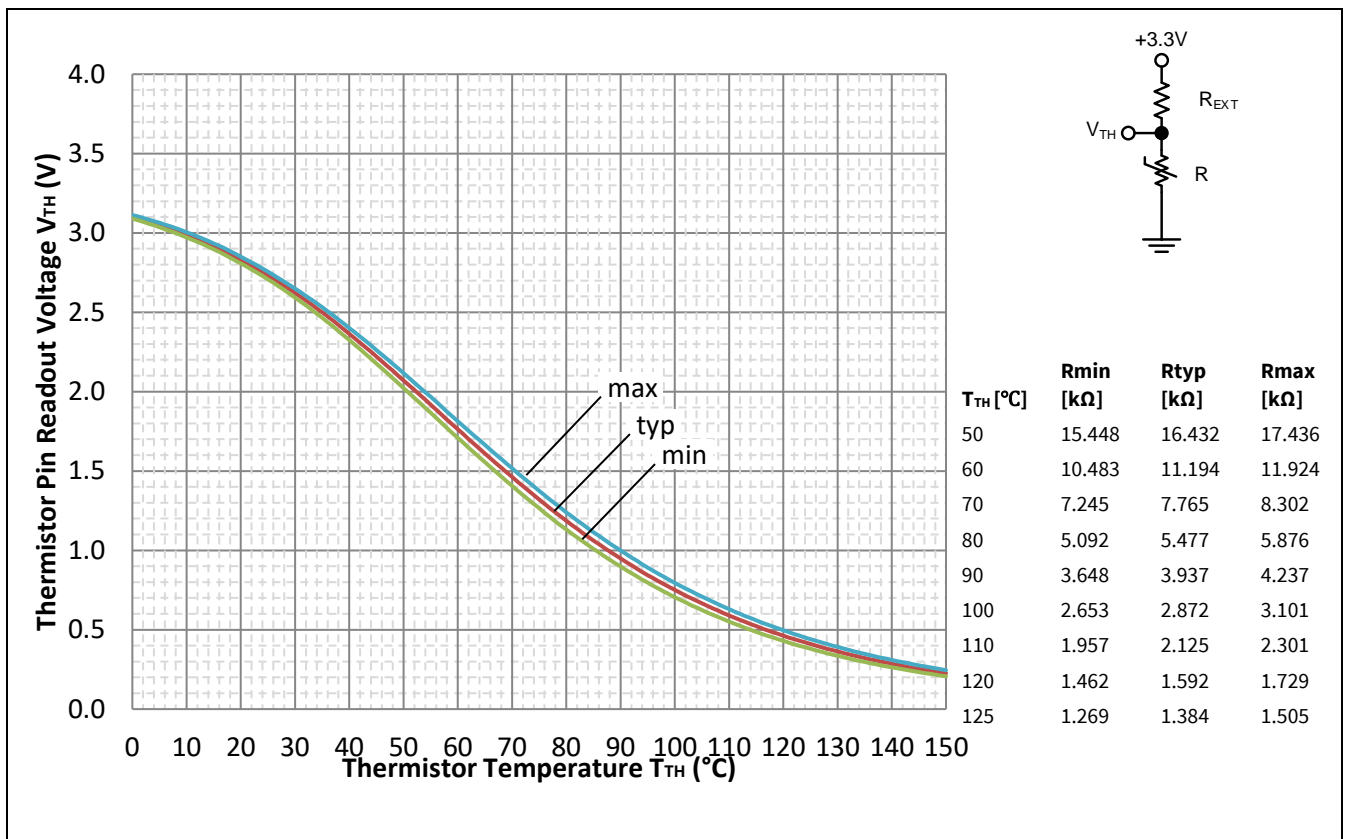

Figure 5 Thermistor resistance - temperature curve, for  $R_{EXT}=9.76\text{k}\Omega$ , and thermistor resistance variation with temperature.

## 9 Qualification Information

Table 13

<b>Moisture sensitivity level</b>	MSL3	
<b>RoHS Compliant</b>	Yes	
<b>ESD</b>	CDM	±2kV, Class C3, per ANSI/ESDA/JEDEC JS-002 standard
	HBM	±2kV, Class 2, per ANSI/ESDA/JEDEC JESD22-A114F standard

## 10 Diagrams & Tables

### 10.1 Input-Output Logic Table

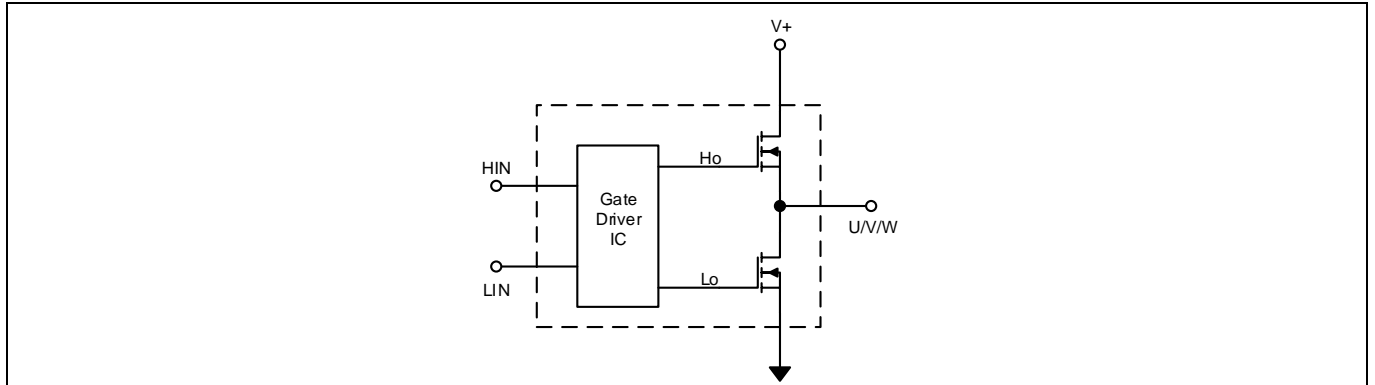

Figure 6 Module block diagram

Table 14

RFE	$I_{TRIP}$	HIN	LIN	U,V,W
1	0	1	0	V+
1	0	0	1	0
1	0	0	0	‡
1	0	1	1	‡
1	1	x	x	‡
0	x	x	x	‡

‡ Voltage depends on direction of phase current

### 10.2 Switching Time Definitions

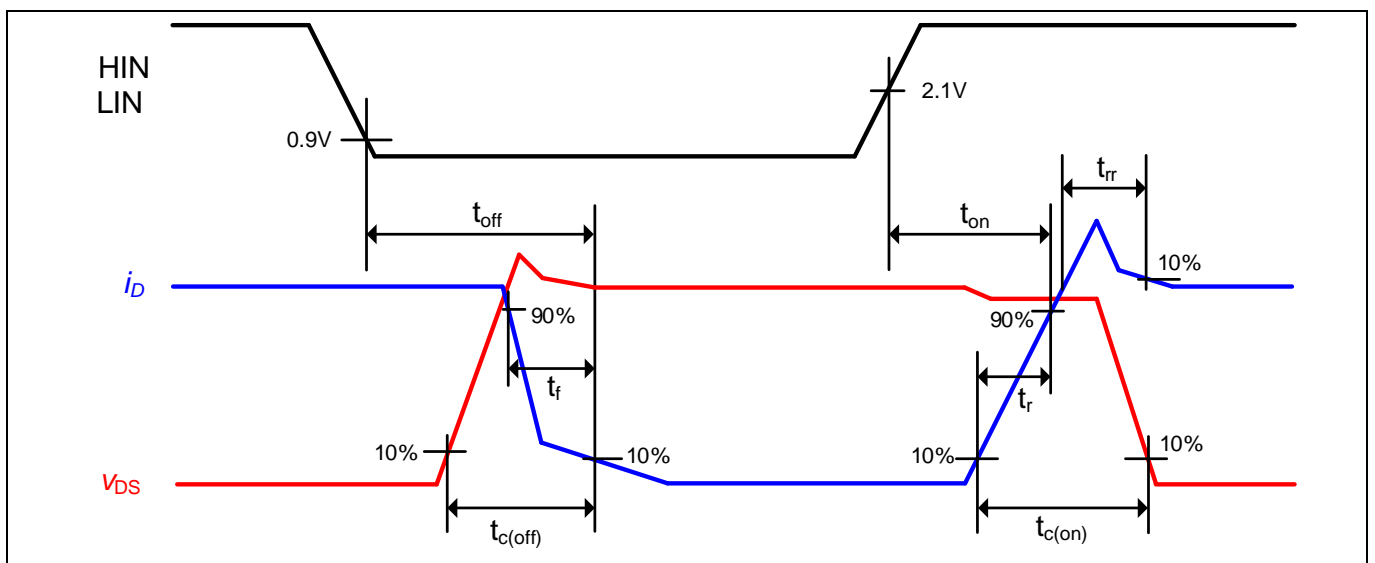

Figure 7 Switching times definition

## 11 Application Guide

### 11.1 Typical Application Schematic

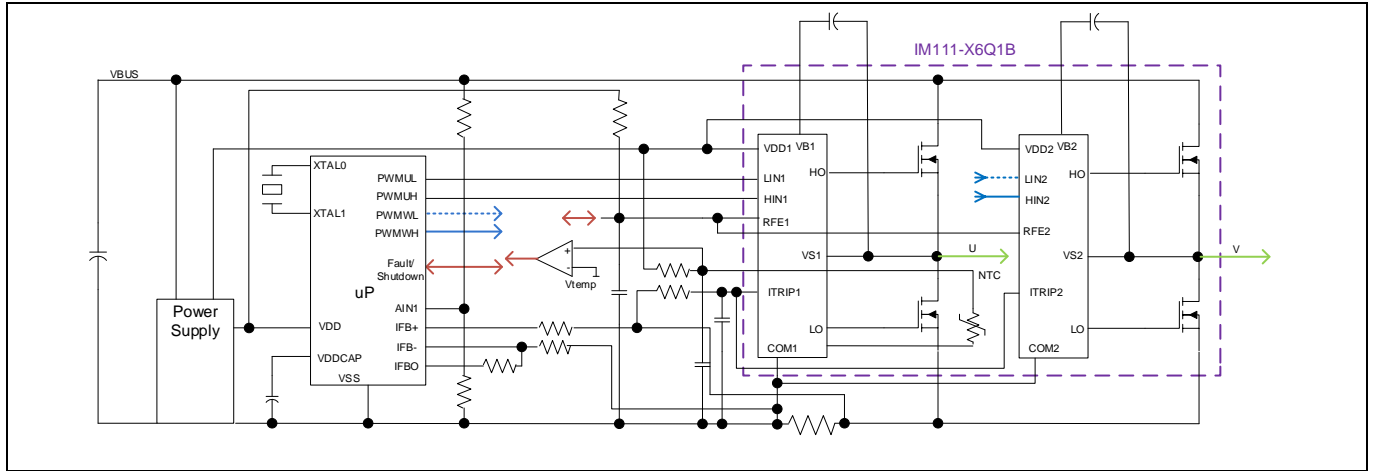

Figure 8 Application schematic

### 11.2 Performance Charts

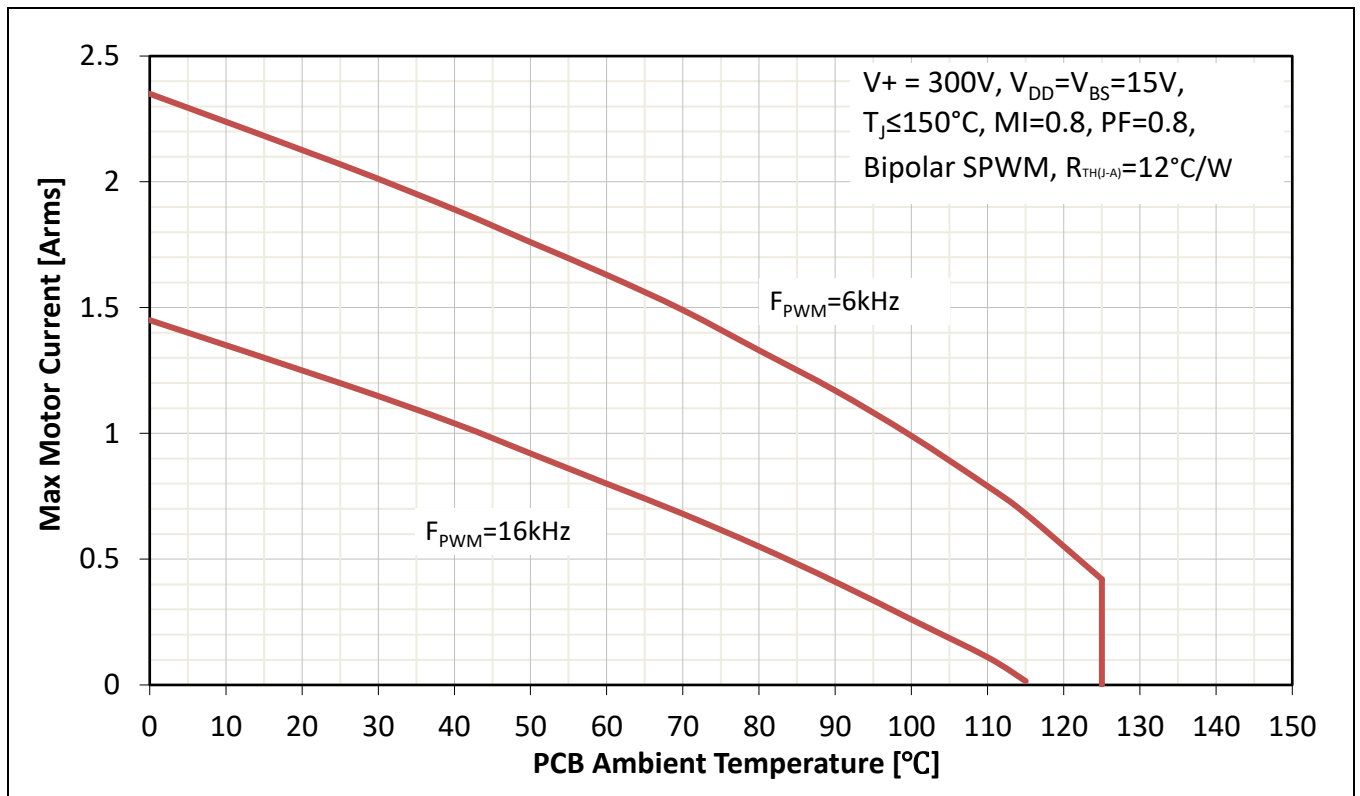

Figure 9 Max current SOA

### 11.3 -Vs Immunity

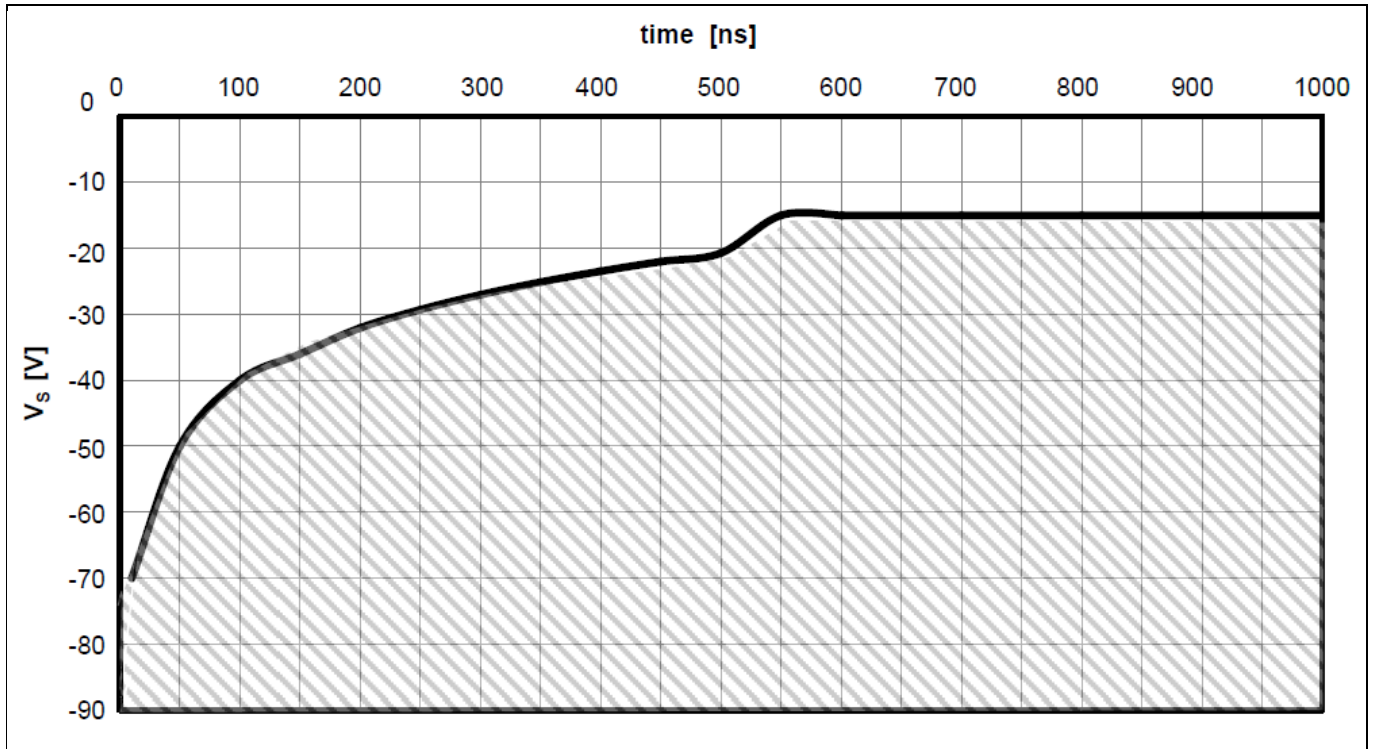
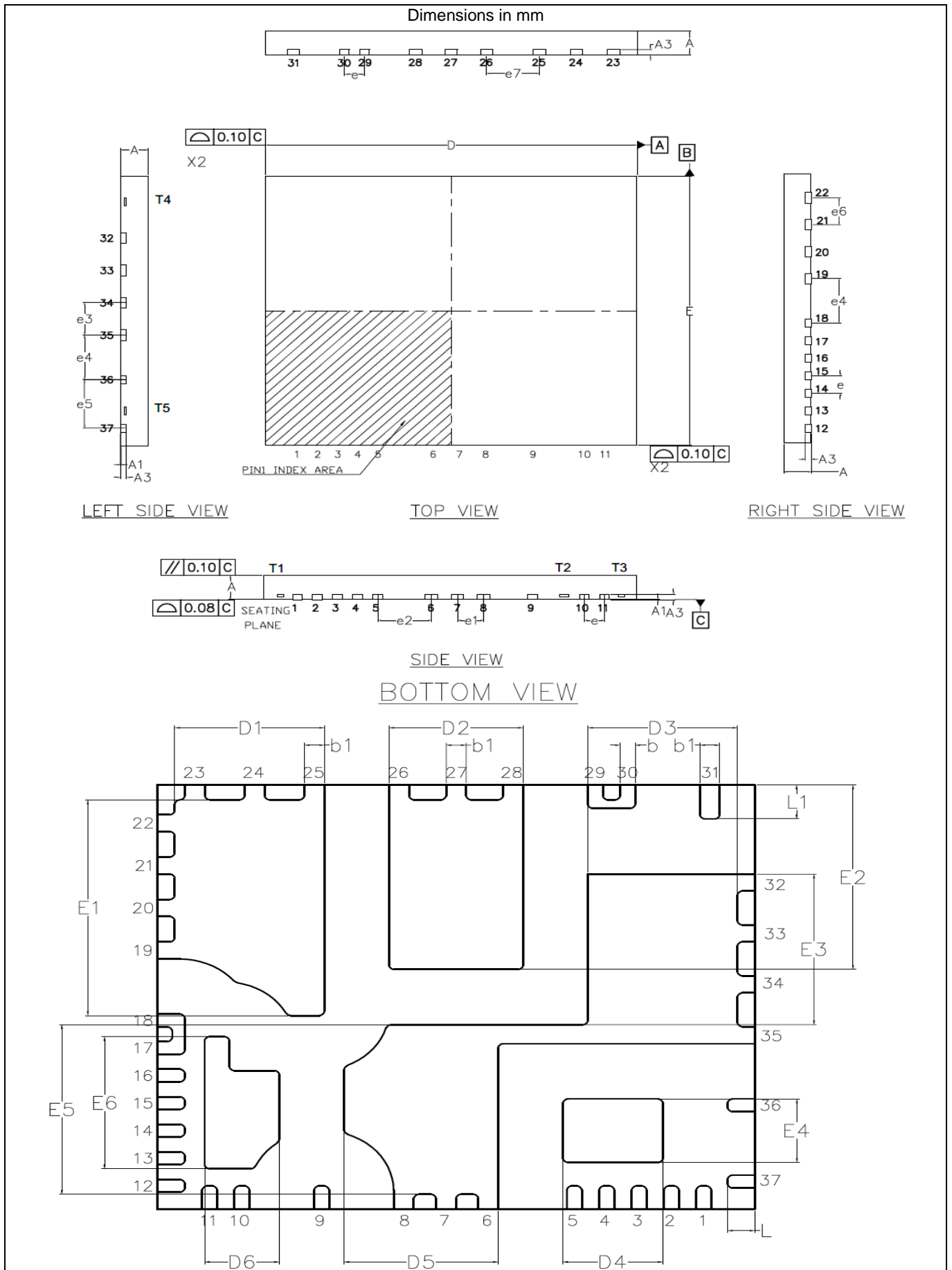

Figure 10 -Vs immunity

## 12 Package Outline



DIMENSIONS	Common					
	DIMENSIONS MILLIMETER			DIMENSIONS INCH		
	MIN.	NOM.	MAX.	MIN.	NOM.	MAX.
A	0.85	0.90	0.95	0.033	0.035	0.037
A1	0.00	0.02	0.05	0.000	0.001	0.002
A3	0.203 REF		0.008 REF			
b	0.250	0.300	0.350	0.010	0.012	0.014
b1	0.350	0.400	0.450	0.014	0.016	0.018
D	11.90	12.00	12.10	0.469	0.472	0.476
E	9.95	10.00	10.10	0.392	0.394	0.398
D1	2.955	3.005	3.055	0.116	0.118	0.120
E1	5.035	5.085	5.135	0.198	0.200	0.202
D2	2.640	2.690	2.740	0.104	0.106	0.108
E2	4.300	4.350	4.400	0.169	0.171	0.173
D3	2.955	3.005	3.055	0.116	0.118	0.120
E3	3.500	3.550	3.600	0.138	0.140	0.142

DIMENSIONS	Common					
	DIMENSIONS mm			DIMENSIONS Inch		
	MIN.	NOM.	MAX.	MIN.	NOM.	MAX.
D4	1.905	2.005	2.105	0.075	0.079	0.083
E4	3.350	3.400	3.450	0.132	0.134	0.136
D5	3.045	3.095	3.145	0.120	0.122	0.124
E5	3.950	4.000	4.050	0.156	0.157	0.159
D6	1.450	1.500	1.550	0.057	0.059	0.061
E6	3.065	3.115	3.165	0.121	0.123	0.125
L	0.500	0.550	0.600	0.020	0.022	0.024
L1	0.750	0.800	0.850	0.030	0.031	0.033
e	0.650 BSC.		0.026 BSC.			
e1	0.848 BSC.		0.033 BSC.			
e2	1.730 BSC.		0.068 BSC.			
e3	1.200 BSC.		0.047 BSC.			
e4	1.650 BSC.		0.065 BSC.			
e5	1.800 BSC.		0.071 BSC.			
e6	1.000 BSC.		0.040 BSC.			
e7	1.700 BSC.		0.067 BSC.			

Note: Exposed tie bars on side of the module.

T1 is internally connected to pin 37

T2 is internally connected to pin 15

T3 is internally connected to pin 12

T4 is internally connected to pin 31

T5 is internally connected to pin 5

## Revision History

### Major changes since the last revision

Page or Reference	Description of change

#### Trademarks

All referenced product or service names and trademarks are the property of their respective owners.

**Edition 2019-12-12**

**Published by**

**Infineon Technologies AG  
81726 München, Germany**

**© 2019 Infineon Technologies AG.  
All Rights Reserved.**

**Do you have a question about this document?**

**Email: [erratum@infineon.com](mailto:erratum@infineon.com)**

**Document reference**

#### IMPORTANT NOTICE

The information given in this document shall in no event be regarded as a guarantee of conditions or characteristics ("Beschaffheitsgarantie").

With respect to any examples, hints or any typical values stated herein and/or any information regarding the application of the product, Infineon Technologies hereby disclaims any and all warranties and liabilities of any kind, including without limitation warranties of non-infringement of intellectual property rights of any third party.

In addition, any information given in this document is subject to customer's compliance with its obligations stated in this document and any applicable legal requirements, norms and standards concerning customer's products and any use of the product of Infineon Technologies in customer's applications.

The data contained in this document is exclusively intended for technically trained staff. It is the responsibility of customer's technical departments to evaluate the suitability of the product for the intended application and the completeness of the product information given in this document with respect to such application.

For further information on the product, technology, delivery terms and conditions and prices please contact your nearest Infineon Technologies office ([www.infineon.com](http://www.infineon.com)).

Please note that this product is not qualified according to the AEC Q100 or AEC Q101 documents of the Automotive Electronics Council.

#### WARNINGS

Due to technical requirements products may contain dangerous substances. For information on the types in question please contact your nearest Infineon Technologies office.

Except as otherwise explicitly approved by Infineon Technologies in a written document signed by authorized representatives of Infineon Technologies, Infineon Technologies' products may not be used in any applications where a failure of the product or any consequences of the use thereof can reasonably be expected to result in personal injury.