

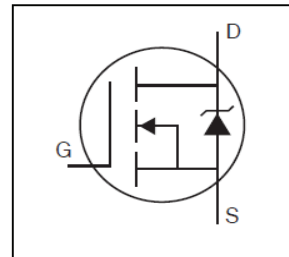
**Features**

- Advanced Process Technology
- Key Parameters Optimized for PDP Sustain, Energy Recovery and Pass Switch Applications
- Low  $E_{PULSE}$  Rating to Reduce Power Dissipation in PDP Sustain, Energy Recovery and Pass Switch Applications
- Low  $Q_G$  for Fast Response
- High Repetitive Peak Current Capability for Reliable Operation
- Short Fall & Rise Times for Fast Switching
- 150°C Operating Junction Temperature for Improved Ruggedness
- Repetitive Avalanche Capability for Robustness and Reliability

HEXFET® Power MOSFET

**Key Parameters**

$V_{DS\ max}$	250	V
$V_{DS\ (Avalanche)\ typ.}$	300	V
$R_{DS(ON)\ typ.\ @\ 10V}$	38	mΩ
$I_{RP\ max\ @\ T_C = 100^\circ C}$	32	A
$T_J\ max$	150	°C



TO-220 Full-Pak

<b>G</b>	<b>D</b>	<b>S</b>
Gate	Drain	Source

**Description**

This HEXFET® Power MOSFET is specifically designed for Sustain; Energy Recovery & Pass switch applications in Plasma Display Panels. This MOSFET utilizes the latest processing techniques to achieve low on-resistance per silicon area and low  $E_{PULSE}$  rating. Additional features of this MOSFET are 150°C operating junction temperature and high repetitive peak current capability. These features combine to make this MOSFET a highly efficient, robust and reliable device for PDP driving applications

Base Part Number	Package Type	Standard Pack		Orderable Part Number
		Form	Quantity	
IRFI4229PbF	TO-220 Full-Pak	Tube	50	IRFI4229PbF

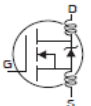
**Absolute Maximum Ratings**

Symbol	Parameter	Max.	Units
$V_{GS}$	Gate-to-Source Voltage	± 30	V
$I_D @ T_C = 25^\circ C$	Continuous Drain Current, $V_{GS} @ 10V$	19	A
$I_D @ T_C = 100^\circ C$	Continuous Drain Current, $V_{GS} @ 10V$	12	
$I_{DM}$	Pulsed Drain Current ①	72	
$I_{RP} @ T_C = 100^\circ C$	Repetitive Peak Current ⑤	32	W
$P_D @ T_C = 25^\circ C$	Maximum Power Dissipation	46	
$P_D @ T_C = 100^\circ C$	Maximum Power Dissipation	18	W/°C
	Linear Derating Factor	0.37	
$T_J$ $T_{STG}$	Operating Junction and Storage Temperature Range	-40 to + 150	°C
	Soldering Temperature, for 10 seconds (1.6mm from case)	300	
	Mounting torque, 6-32 or M3 screw	10 lbf•in (1.1N•m)	

**Thermal Resistance**

Symbol	Parameter	Typ.	Max.	Units
$R_{\theta JC}$	Junction-to-Case ④	—	2.73	°C/W
$R_{\theta JA}$	Junction-to-Ambient	—	65	

**Electrical Characteristics @ T<sub>J</sub> = 25°C (unless otherwise specified)**

	Parameter	Min.	Typ.	Max.	Units	Conditions
V <sub>(BR)DSS</sub>	Drain-to-Source Breakdown Voltage	250	—	—	V	V <sub>GS</sub> = 0V, I <sub>D</sub> = 250μA
ΔV <sub>(BR)DSS</sub> /ΔT <sub>J</sub>	Breakdown Voltage Temp. Coefficient	—	340	—	mV/°C	Reference to 25°C, I <sub>D</sub> = 1mA
R <sub>DS(on)</sub>	Static Drain-to-Source On-Resistance	—	38	46	mΩ	V <sub>GS</sub> = 10V, I <sub>D</sub> = 11A
V <sub>GS(th)</sub>	Gate Threshold Voltage	3.0	—	5.0	V	V <sub>DS</sub> = V <sub>GS</sub> , I <sub>D</sub> = 250μA
ΔV <sub>GS(th)</sub> /ΔT <sub>J</sub>	Gate Threshold Voltage Temp. Coefficient	—	-12	—	mV/°C	
I <sub>DSS</sub>	Drain-to-Source Leakage Current	—	—	20	μA	V <sub>DS</sub> = 250V, V <sub>GS</sub> = 0V
		—	—	200		V <sub>DS</sub> = 250V, V <sub>GS</sub> = 0V, T <sub>J</sub> = 150°C
I <sub>GSS</sub>	Gate-to-Source Forward Leakage	—	—	100	nA	V <sub>GS</sub> = 20V
	Gate-to-Source Reverse Leakage	—	—	-100		V <sub>GS</sub> = -20V
g <sub>fs</sub>	Forward Trans conductance	26	—	—	S	V <sub>DS</sub> = 25V, I <sub>D</sub> = 11A
Q <sub>g</sub>	Total Gate Charge	—	73	110	nC	I <sub>D</sub> = 11A, V <sub>DS</sub> = 125V
Q <sub>gd</sub>	Gate-to-Drain Charge	—	24	—		V <sub>GS</sub> = 10V
t <sub>d(on)</sub>	Turn-On Delay Time	—	18	—	ns	V <sub>DD</sub> = 125V, V <sub>GS</sub> = 10V
t <sub>r</sub>	Rise Time	—	17	—		I <sub>D</sub> = 11A
t <sub>d(off)</sub>	Turn-Off Delay Time	—	32	—		R <sub>G</sub> = 2.4Ω
t <sub>f</sub>	Fall Time	—	13	—		See Fig. 22
t <sub>st</sub>	Shoot Through Blocking Time	100	—	—	ns	V <sub>DD</sub> = 200V, V <sub>GS</sub> = 15V, R <sub>G</sub> = 5.1Ω
E <sub>PULSE</sub>	Energy per Pulse	—	770	—	μJ	L = 220nH, C = 0.3μF, V <sub>GS</sub> = 15V V <sub>DD</sub> = 200V, R <sub>G</sub> = 5.1Ω, T <sub>J</sub> = 25°C
		—	1380	—		L = 220nH, C = 0.3μF, V <sub>GS</sub> = 15V V <sub>DD</sub> = 200V, R <sub>G</sub> = 5.1Ω, T <sub>J</sub> = 100°C
C <sub>iSS</sub>	Input Capacitance	—	4480	—	pF	V <sub>GS</sub> = 0V
C <sub>oSS</sub>	Output Capacitance	—	400	—		V <sub>DS</sub> = 25V
C <sub>rSS</sub>	Reverse Transfer Capacitance	—	100	—		f = 1.0MHz
C <sub>oSS eff.</sub>	Effective Output Capacitance	—	270	—		V <sub>GS</sub> = 0V, V <sub>DS</sub> = 0V to 200V
L <sub>D</sub>	Internal Drain Inductance	—	4.5	—	nH	Between lead, 6mm (0.25in.) from package and center of die contact : 
L <sub>S</sub>	Internal Source Inductance	—	7.5	—		

**Avalanche Characteristics**

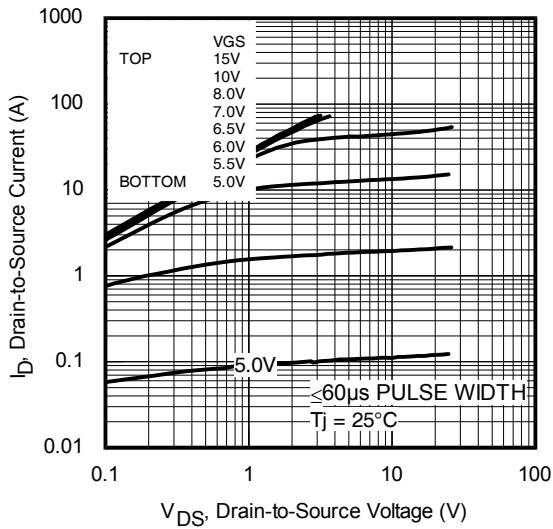
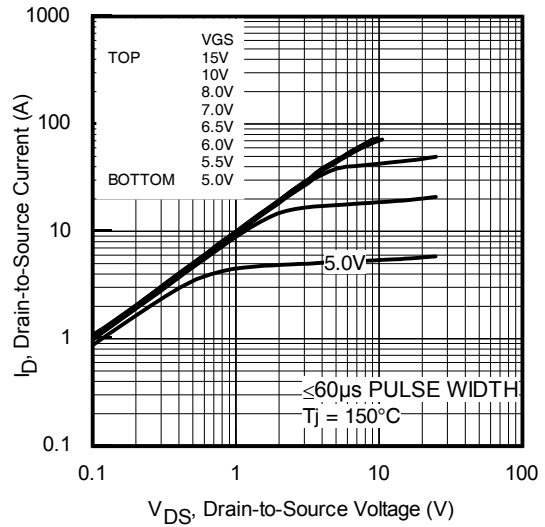
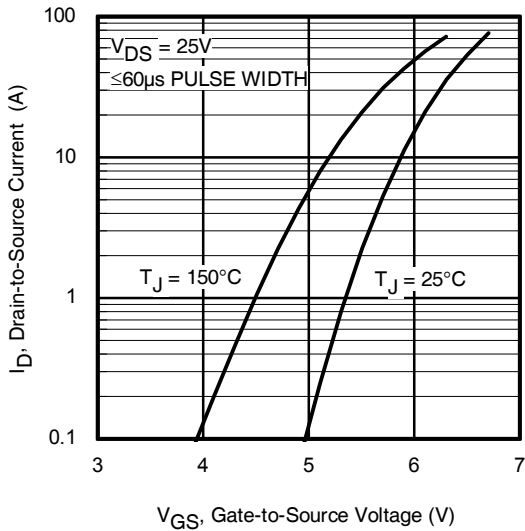
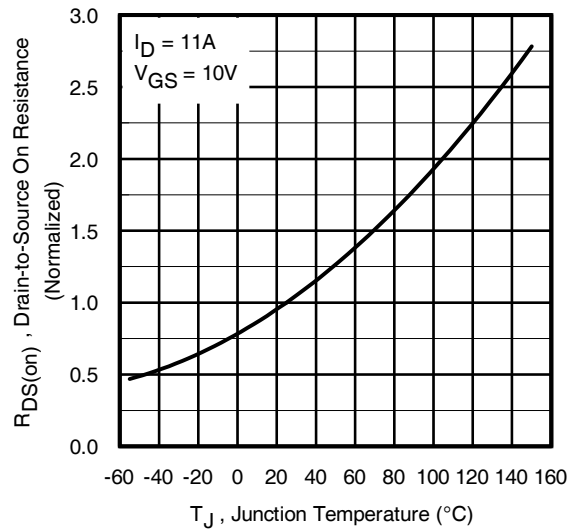
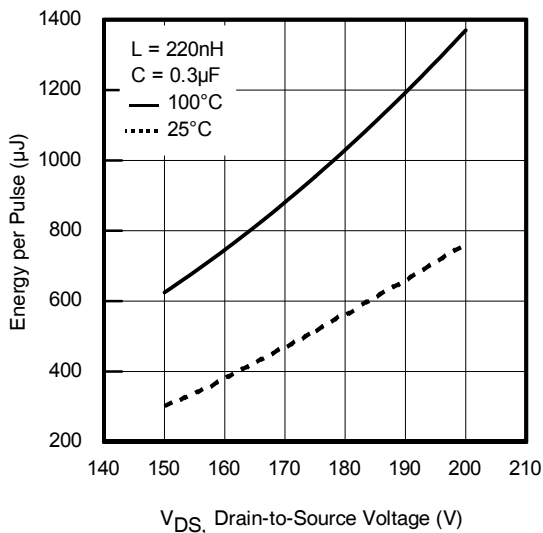
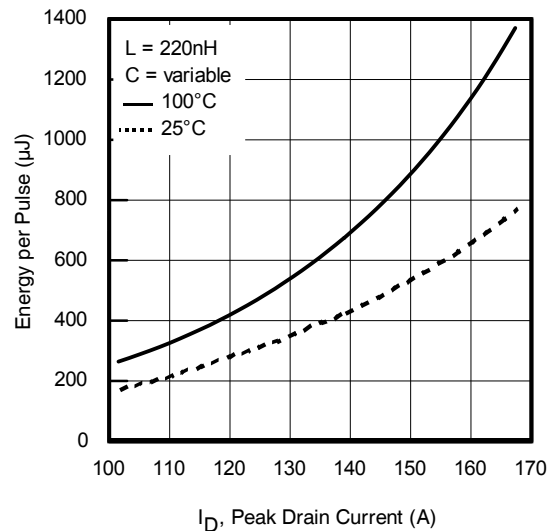
	Parameter	Typ.	Max.	Units
E <sub>AS</sub>	Single Pulse Avalanche Energy ②	—	110	mJ
E <sub>AR</sub>	Repetitive Avalanche Energy ①	—	4.6	
V <sub>DS(Avalanche)</sub>	Repetitive Avalanche Voltage ①	300	—	V
I <sub>AS</sub>	Avalanche Current ②	—	11	A

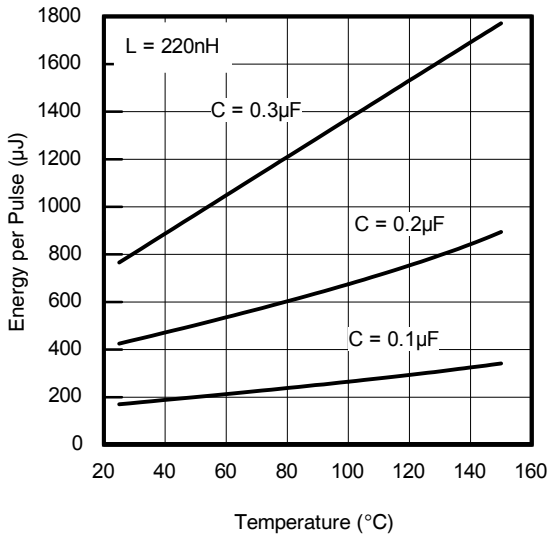
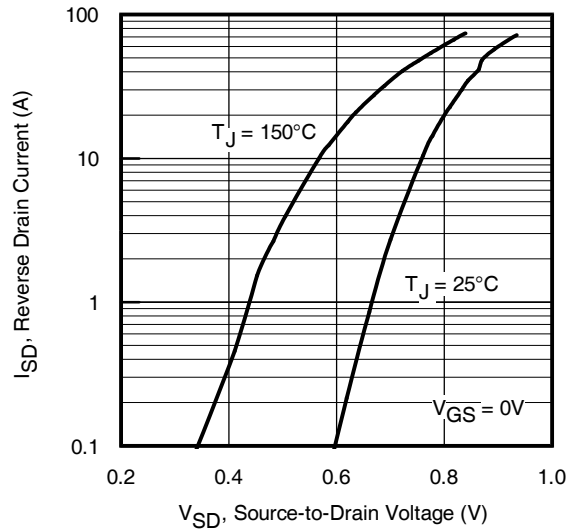
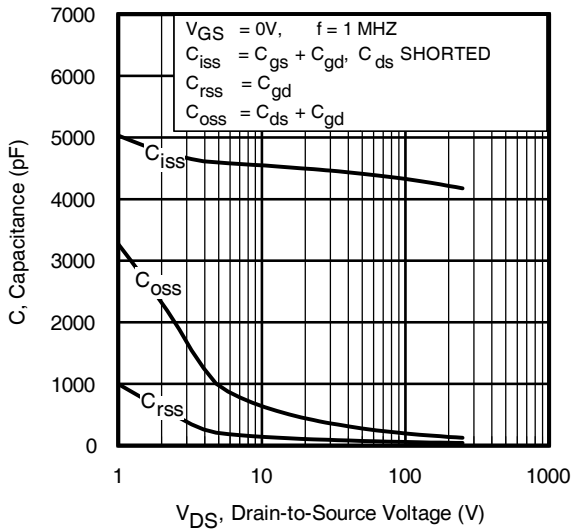
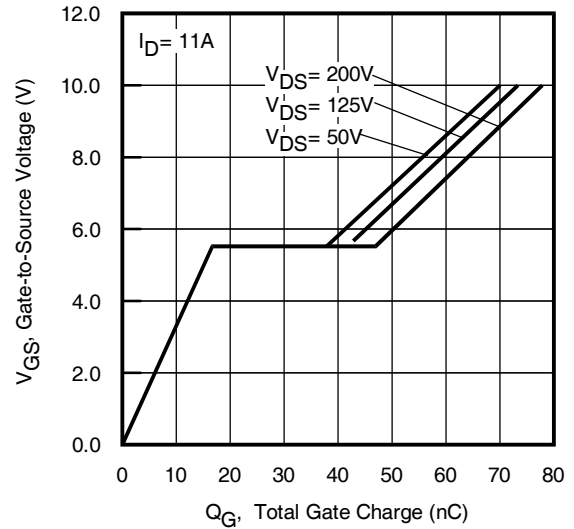
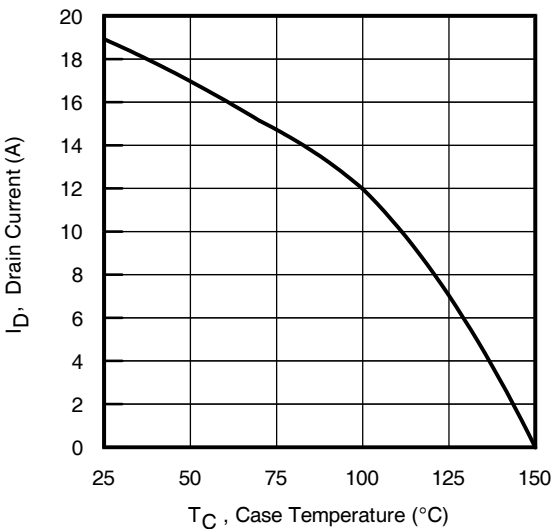
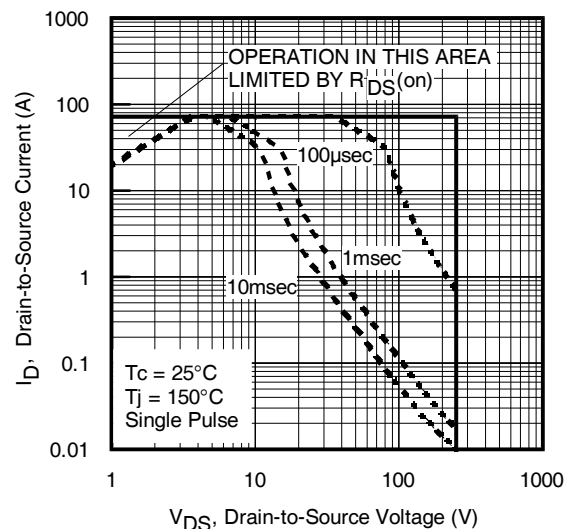
**Diode Characteristics**

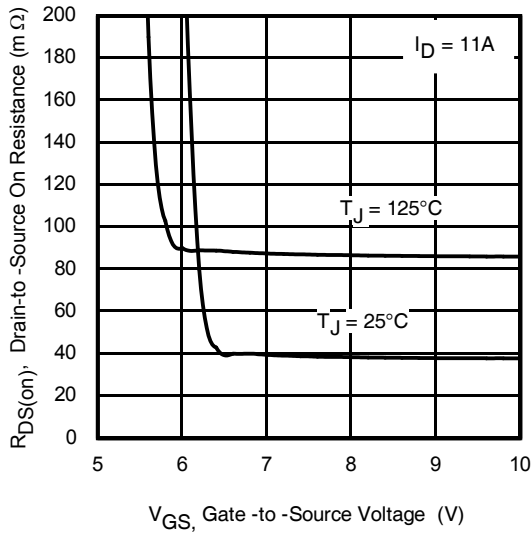
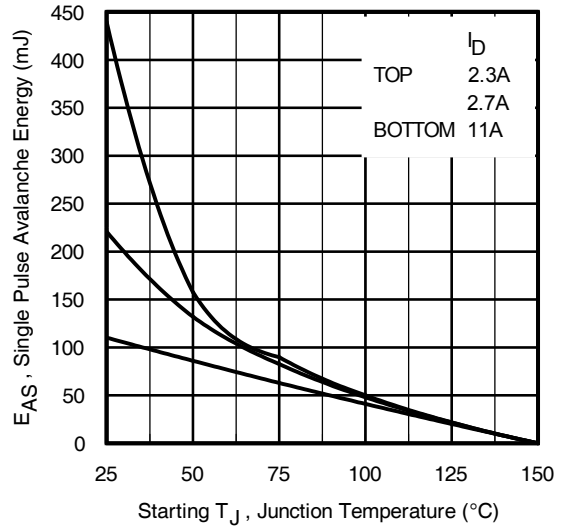
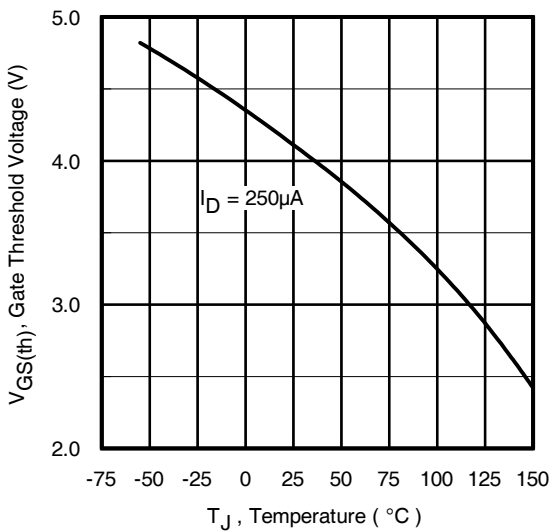
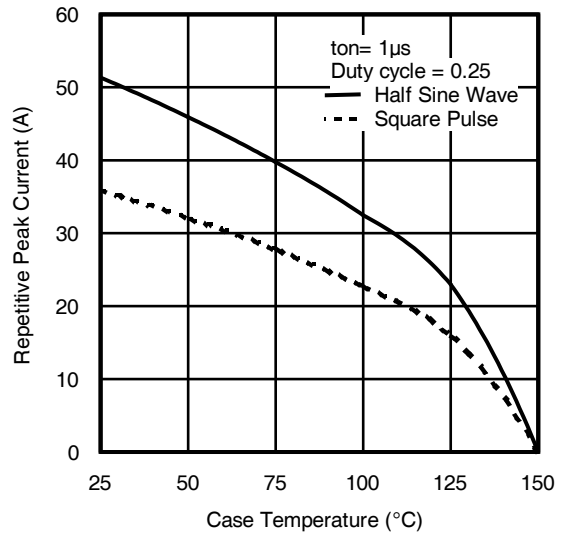
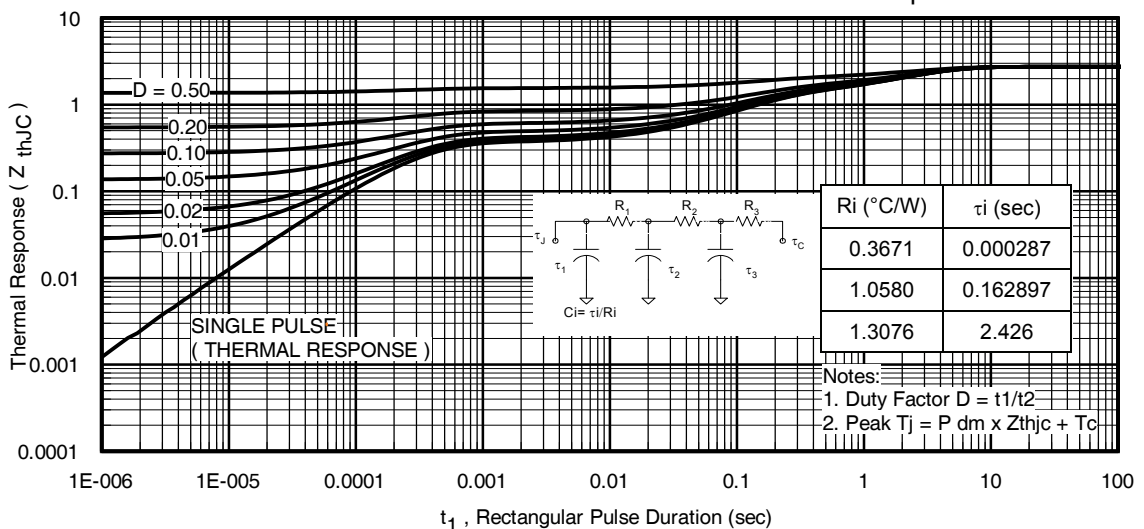
	Parameter	Min.	Typ.	Max.	Units	Conditions
I <sub>S</sub> @ T <sub>C</sub> = 25°C	Continuous Source Current (Body Diode)	—	—	18	A	MOSFET symbol showing the integral reverse p-n junction diode.
I <sub>SM</sub>	Pulsed Source Current (Body Diode) ①	—	—	72		
V <sub>SD</sub>	Diode Forward Voltage	—	—	1.3	V	T <sub>J</sub> = 25°C, I <sub>S</sub> = 11A, V <sub>GS</sub> = 0V ③
t <sub>rr</sub>	Reverse Recovery Time	—	120	180	ns	T <sub>J</sub> = 25°C, I <sub>F</sub> = 11A, V <sub>DD</sub> = 50V
Q <sub>rr</sub>	Reverse Recovery Charge	—	540	810	nC	di/dt = 100A/μs ③

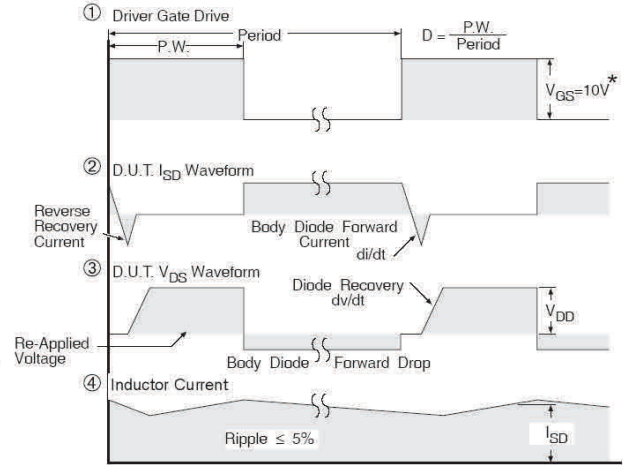
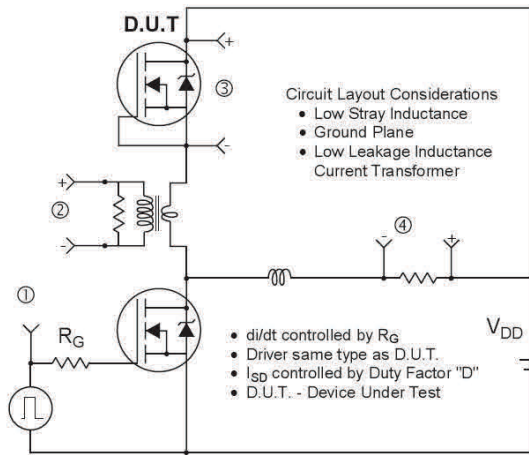
**Notes:**

- ① Repetitive rating; pulse width limited by max. junction temperature.
- ② starting T<sub>J</sub> = 25°C, L = 1.9mH, R<sub>G</sub> = 25Ω, I<sub>AS</sub> = 11A.
- ③ Pulse width ≤ 400μs; duty cycle ≤ 2%.
- ④ R<sub>θ</sub> is measured at T<sub>J</sub> of approximately 90°C.
- ⑤ Half sine wave with duty cycle = 0.25, ton = 1μsec.


**Fig. 1. Typical Output Characteristics**

**Fig. 2. Typical Output Characteristics**

**Fig. 3. Typical Transfer Characteristics**

**Fig. 4. Normalized On-Resistance vs. Temperature**

**Fig 5. Typical  $E_{PULSE}$  vs. Drain-to-Source Voltage**

**Fig 6. Typical  $E_{PULSE}$  vs. Drain Current**

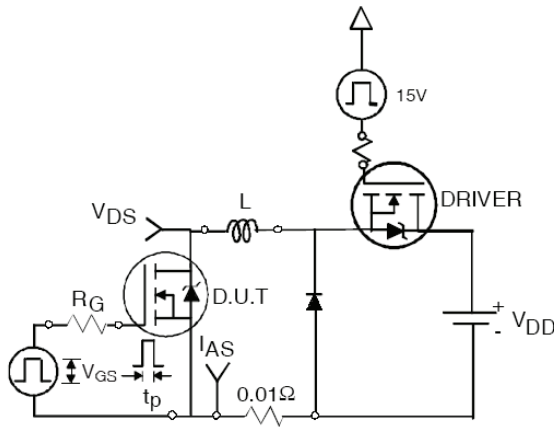

**Fig. 7.** Typical  $E_{PULSE}$  vs. Temperature

**Fig 8.** Typical Source-Drain Diode Forward Voltage

**Fig 9.** Typical Capacitance vs. Drain-to-Source Voltage

**Fig 10.** Typical Gate Charge vs. Gate-to-Source Voltage

**Fig 11.** Maximum Drain Current vs. Case Temperature

**Fig 12.** Maximum Safe Operating Area


**Fig. 13.** On-Resistance Vs. Gate Voltage

**Fig. 14.** Maximum Avalanche Energy Vs. Temperature

**Fig. 15.** Threshold Voltage vs. Temperature

**Fig. 16.** Typical Repetitive peak Current vs. Case temperature

**Fig 17.** Maximum Effective Transient Thermal Impedance, Junction-to-Case

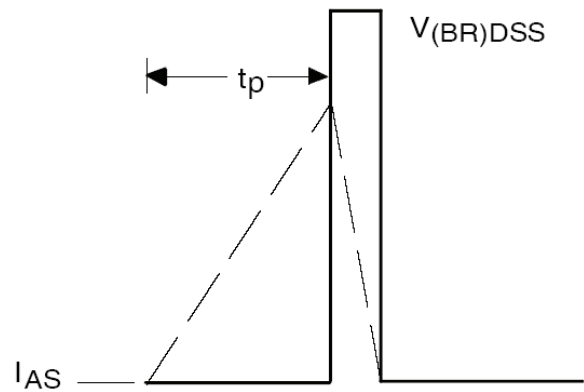


\*  $V_{GS} = 5V$  for Logic Level Devices

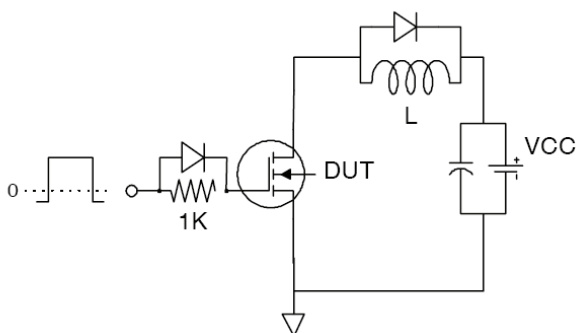
**Fig 18.** Diode Reverse Recovery Test Circuit for N-Channel HEXFET® Power MOSFETs



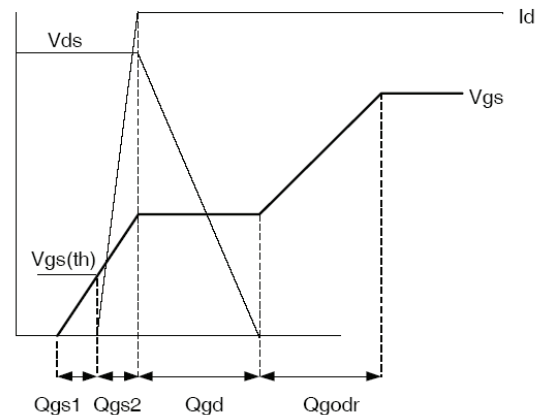
**Fig 19a.** Unclamped Inductive Test Circuit



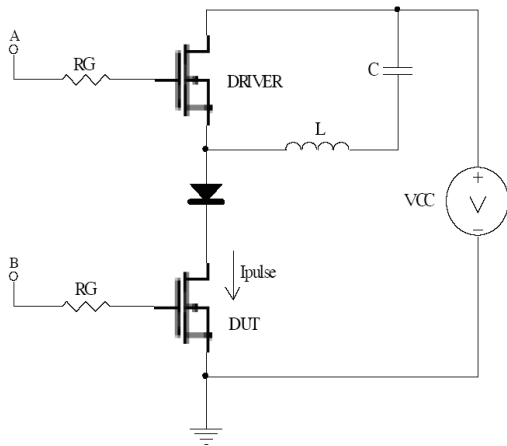
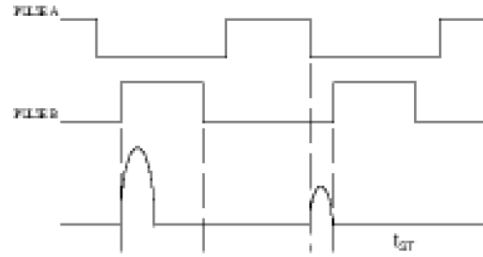
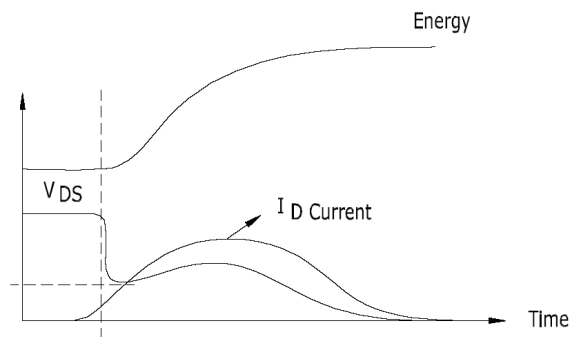
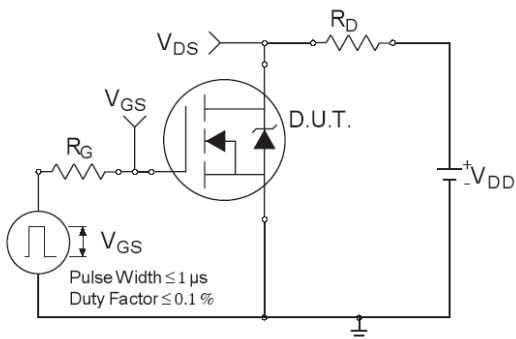
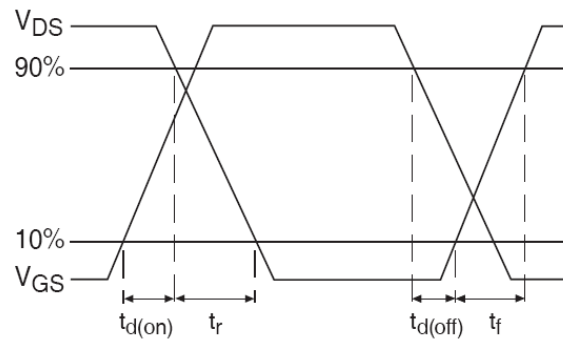
**Fig 19b.** Unclamped Inductive Waveforms

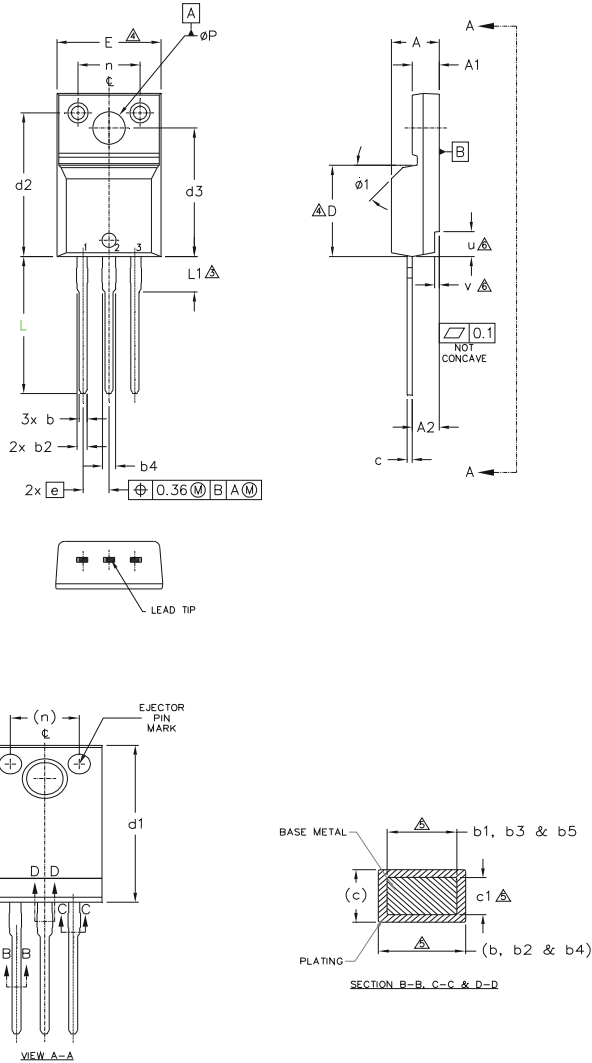


**Fig 20a.** Gate Charge Test Circuit



**Fig 20b.** Gate Charge Waveform


**Fig 21a.**  $t_{st}$  and  $E_{PULSE}$  Test Circuit

**Fig 21b.**  $t_{st}$  Test Waveforms

**Fig 21c.**  $E_{PULSE}$  Test Waveforms

**Fig 22a.** Switching Time Test Circuit

**Fig 22b.** Switching Time Waveforms

**TO-220 Full-Pak Package Outline (Dimensions are shown in millimeters (inches))**

**NOTES:**

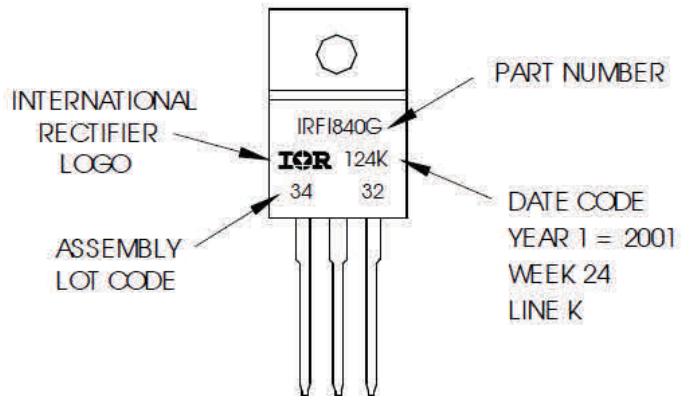
- 1.0 DIMENSIONING AND TOLERANCING AS PER ASME Y14.5 M- 1994.
- 2.0 DIMENSIONS ARE SHOWN IN MILLIMETERS [INCHES].
- 3.0 LEAD DIMENSION AND FINISH UNCONTROLLED IN L1.
- 4.0 DIMENSION D & E DO NOT INCLUDE MOLD FLASH. MOLD FLASH SHALL NOT EXCEED .005" (0.127) PER SIDE. THESE DIMENSIONS ARE MEASURED AT THE OUTER MOST EXTREMES OF THE PLASTIC BODY.
- 5.0 DIMENSION b1, b3, b5 & c1 APPLY TO BASE METAL ONLY.
- 6.0 STEP OPTIONAL ON PLASTIC BODY DEFINED BY DIMENSIONS u & v.
- 7.0 CONTROLLING DIMENSION : INCHES.

SYMBOL	DIMENSIONS				NOTES
	MILLIMETERS		INCHES		
	MIN.	MAX.	MIN.	MAX.	
A	4.57	4.83	.180	.190	<b>LEAD ASSIGNMENTS</b>  <u>HEXFET</u> 1.- GATE 2.- DRAIN 3.- SOURCE  <u>IGBTs, CoPACK</u> 1.- GATE 2.- COLLECTOR 3.- EMITTER
A1	2.57	2.82	.101	.111	
A2	2.51	2.92	.099	.115	
b	0.61	0.94	.024	.037	
b1	0.61	0.89	.024	.035	
b2	0.76	1.27	.030	.050	
b3	0.76	1.22	.030	.048	
b4	1.02	1.52	.040	.060	
b5	1.02	1.47	.040	.058	
c	0.33	0.63	.013	.025	
c1	0.33	0.58	.013	.023	
D	8.66	9.80	.341	.386	
d1	15.80	16.13	.622	.635	
d2	13.97	14.22	.550	.560	
d3	12.29	12.93	.484	.509	
E	9.63	10.74	.379	.423	
e	2.54 BSC		.100 BSC		
L	13.21	13.72	.520	.540	
L1	3.10	3.68	.122	.145	
n	6.05	6.60	.238	.260	
øP	3.05	3.45	.120	.136	
u	2.39	2.49	.094	.098	
v	0.41	0.51	.016	.020	
ø1	-	45°	-	45°	

**TO-220 Full-Pak Part Marking Information**

**EXAMPLE:** THIS IS AN IRFI840G  
 WITH ASSEMBLY  
 LOT CODE 3432  
 ASSEMBLED ON WW24, 2001  
 IN THE ASSEMBLY LINE "K"

Note: "P" in assembly line position  
 indicates "Lead-Free"



TO-220AB Full-Pak packages are not recommended for Surface Mount Application.

Note: For the most current drawing please refer to website at <http://www.irf.com/package/>

**Qualification Information**

<b>Qualification Level</b>	Industrial (per JEDEC JESD47F) †	
<b>Moisture Sensitivity Level</b>	TO-220 Full-Pak	N/A
<b>RoHS Compliant</b>	Yes	

† Applicable version of JEDEC standard at the time of product release.

**Revision History**

Date	Comments
04/27/2017	<ul style="list-style-type: none"> <li>Changed datasheet with Infineon logo - all pages.</li> <li>Corrected Package Outline on page 8.</li> <li>Added disclaimer on last page.</li> </ul>

**Trademarks of Infineon Technologies AG**

µHVIC™, µIPM™, µPFC™, AU-ConvertIR™, AURIX™, C166™, CanPAK™, CIPOS™, CIPURSE™, CoolDP™, CoolGaN™, COOLiR™, CoolMOST™, CoolSET™, CoolSiC™, DAVE™, DI-POL™, DirectFET™, DrBlade™, EasyPIM™, EconoBRIDGE™, EconoDUAL™, EconoPACK™, EconoPIM™, EiceDRIVER™, eupec™, FCOS™, GaNpowIR™, HEXFET™, HITFET™, HybridPACK™, iMOTION™, IRAM™, ISOFACE™, IsoPACK™, LEDrivIR™, LITIX™, MIPAQ™, ModSTACK™, my-d™, NovalithIC™, OPTIGA™, OptiMOST™, ORIGA™, PowIRaudio™, PowIRstage™, PrimePACK™, PrimeSTACK™, PROFET™, PRO-SiL™, RASiC™, REAL3™, SmartLEWIS™, SOLID FLASH™, SPOC™, StrongIRFET™, SupIRBuck™, TEMPFET™, TRENCHSTOP™, TriCore™, UHVIC™, XHP™, XMC™

Trademarks updated November 2015

**Other Trademarks**

All referenced product or service names and trademarks are the property of their respective owners.

**Edition 2016-04-19**

**Published by**

**Infineon Technologies AG**

**81726 Munich, Germany**

© 2016 Infineon Technologies AG.

All Rights Reserved.

**Do you have a question about this document?**

**Email:** [erratum@infineon.com](mailto:erratum@infineon.com)

**Document reference**

**ifx1**

**IMPORTANT NOTICE**

The information given in this document shall in no event be regarded as a guarantee of conditions or **characteristics ("Beschaffenheitsgarantie")**.

With respect to any examples, hints or any typical values stated herein and/or any information regarding the application of the product, Infineon Technologies hereby disclaims any and all warranties and liabilities of any kind, including without limitation warranties of non-infringement of intellectual property rights of any third party.

In addition, any information given in this document **is subject to customer's compliance with its obligations** stated in this document and any applicable legal requirements, norms and standards concerning customer's products and any use of the product of Infineon Technologies in **customer's applications**.

The data contained in this document is exclusively intended for technically trained staff. It is the **responsibility of customer's technical departments** to evaluate the suitability of the product for the intended application and the completeness of the product information given in this document with respect to such application.

For further information on the product, technology, delivery terms and conditions and prices please contact your nearest Infineon Technologies office ([www.infineon.com](http://www.infineon.com)).

Please note that this product is not qualified according to the AEC Q100 or AEC Q101 documents of the Automotive Electronics Council.

**WARNINGS**

Due to technical requirements products may contain dangerous substances. For information on the types in question please contact your nearest Infineon Technologies office.

Except as otherwise explicitly approved by Infineon Technologies in a written document signed by authorized representatives of Infineon Technologies, **Infineon Technologies' products may not be used** in any applications where a failure of the product or any consequences of the use thereof can reasonably be expected to result in personal injury.