

Memory FRAM

16 K (2 K × 8) Bit I²C

MB85RC16V

■ DESCRIPTION

The MB85RC16V is an FRAM (Ferroelectric Random Access Memory) chip in a configuration of 2,048 words × 8 bits, using the ferroelectric process and silicon gate CMOS process technologies for forming the nonvolatile memory cells.

Unlike SRAM, the MB85RC16V is able to retain data without using a data backup battery.

The memory cells used in the MB85RC16V have at least 10¹² Read/Write operation endurance per byte, which is a significant improvement over the number of read/write operations than by other nonvolatile memory products.

The MB85RC16V can provide writing in one byte units because the long writing time is not required unlike Flash memory and E²PROM. Therefore, the writing completion waiting sequence like a write busy state is not required.

■ FEATURES

- Bit configuration : 2,048 words × 8 bits
- Two-wire serial interface : Fully controllable by two ports: serial clock (SCL) and serial data (SDA).
- Operating frequency : 1 MHz (Max)
- Read/Write endurance : 10¹² times / byte
- Data retention : 10 years (+ 85 °C), 95 years (+ 55 °C), over 200 years (+ 35 °C)
- Operating power supply voltage : 3.0 V to 5.5 V
- Low power consumption : Operating power supply current 90 μA (Typ @1 MHz)
Standby current 5 μA (Typ)
- Operation ambient temperature range: – 40 °C to + 85 °C
- Package : 8-pin plastic SOP (FPT-8P-M02)
RoHS compliant

MB85RC16V

■ PIN ASSIGNMENT

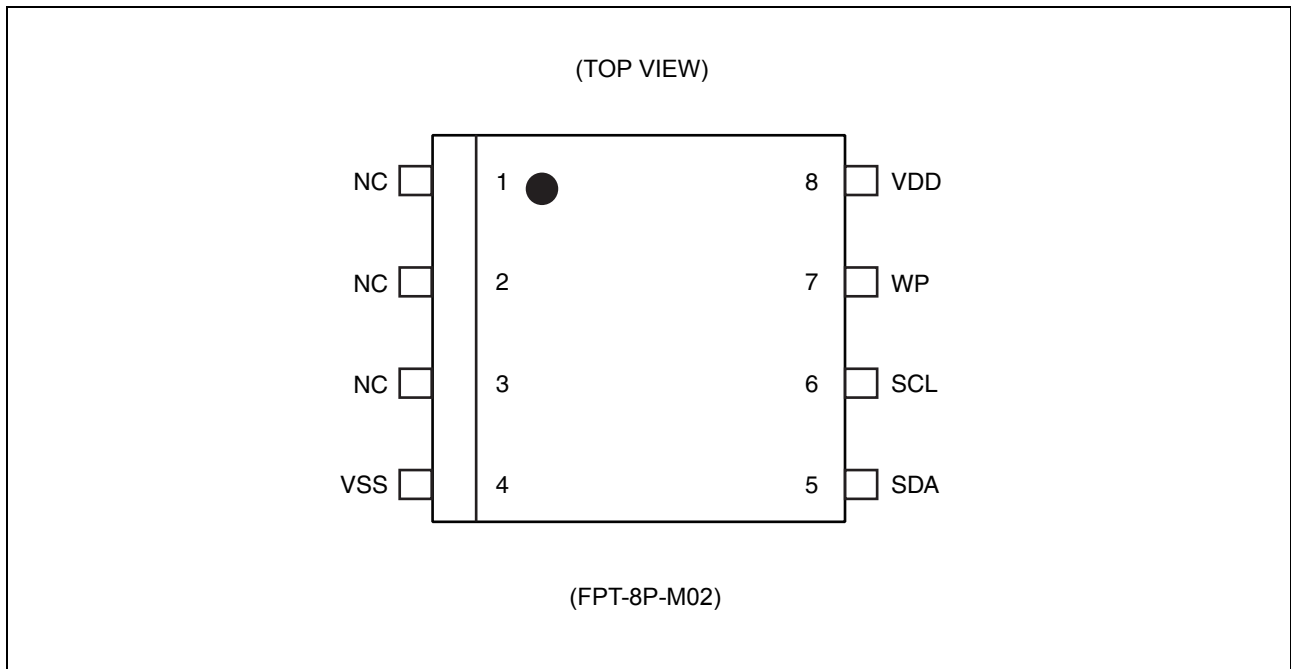

■ PIN FUNCTIONAL DESCRIPTIONS

Pin Number	Pin Name	Functional Description
1 to 3	NC	No Connect pins Leave these pins open, or connect to VDD or VSS.
4	VSS	Ground pin
5	SDA	Serial Data I/O pin This is an I/O pin which performs bidirectional communication for both memory address and writing/reading data. It is possible to connect multiple devices. It is an open drain output, so a pull-up resistor is required to be connected to the external circuit.
6	SCL	Serial Clock pin This is a clock input pin for input/output serial data. Data is sampled on the rising edge of the clock and output on the falling edge.
7	WP	Write Protect pin When the Write Protect pin is the "H" level, writing operation is disabled. When the Write Protect pin is the "L" level, the entire memory region can be overwritten. Reading operation is always enabled regardless of the Write Protect pin input level. The Write Protect pin is internally pulled down to the VSS pin and, that is recognized as the "L" level (write enabled) when the pin is the open state.
8	VDD	Supply Voltage pin

■ BLOCK DIAGRAM

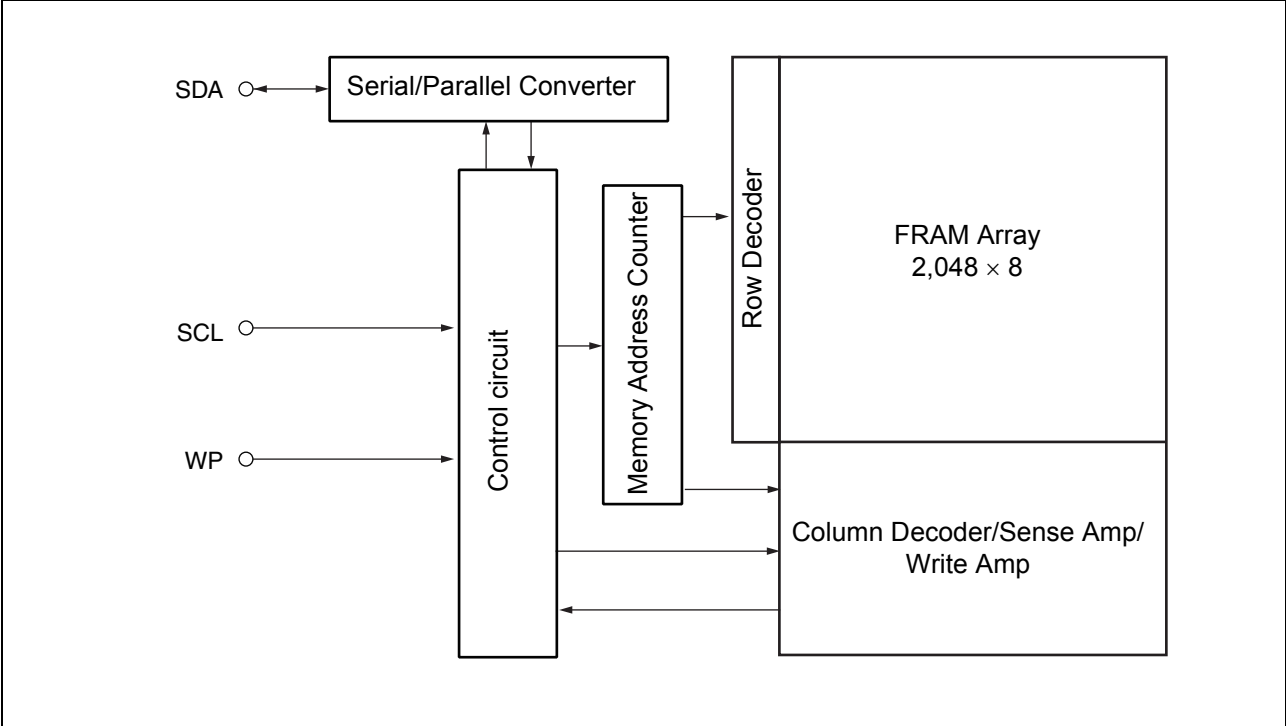

■ I²C (Inter-Integrated Circuit)

The MB85RC16V has the two-wire serial interface; the I²C bus, and operates as a slave device. The I²C bus defines communication roles of “master” and “slave” devices, with the master side holding the authority to initiate control. Furthermore, an I²C bus connection is possible where a single master device is connected to multiple slave devices in a party-line configuration.

● I²C Interface System Configuration Example

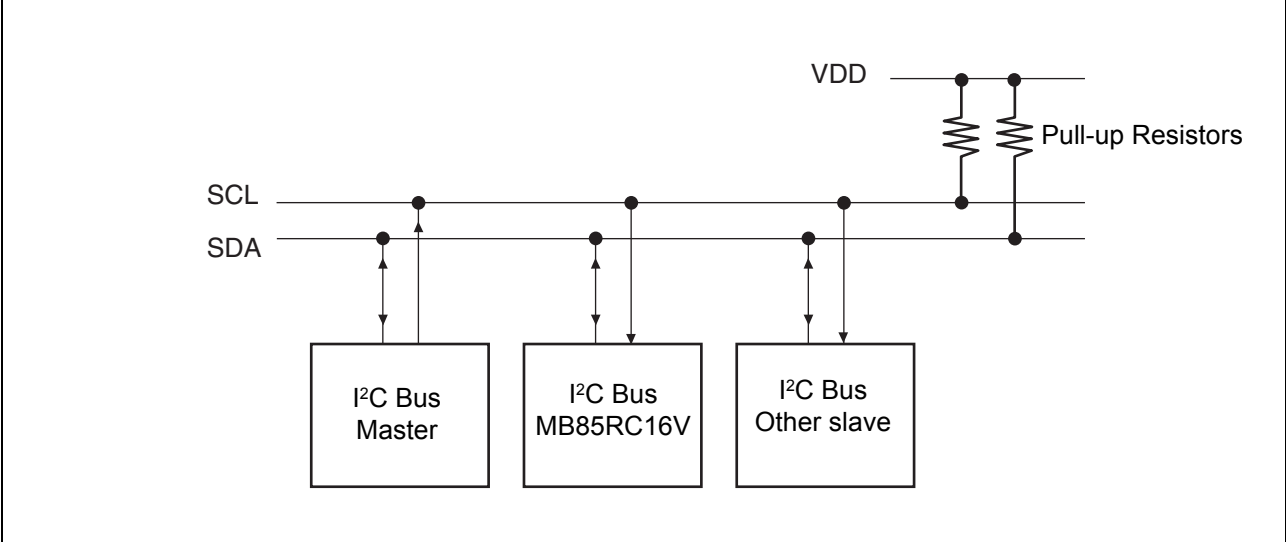

■ I²C COMMUNICATION PROTOCOL

The I²C bus provides communication by two wires only, therefore, the SDA input should change while the SCL is the "L" level. However, when starting and stopping the communication sequence, the SDA is allowed to change while the SCL is the "H" level.

- Start Condition

To start read or write operations by the I²C bus, change the SDA input from the "H" level to the "L" level while the SCL input is in the "H" level.

- Stop Condition

To stop the I²C bus communication, change the SDA input from the "L" level to the "H" level while the SCL input is in the "H" level. In the reading operation, inputting the stop condition finishes reading and enters the standby state. In the writing operation, inputting the stop condition finishes inputting the rewrite data and enters the standby state.

- Start Condition, Stop Condition

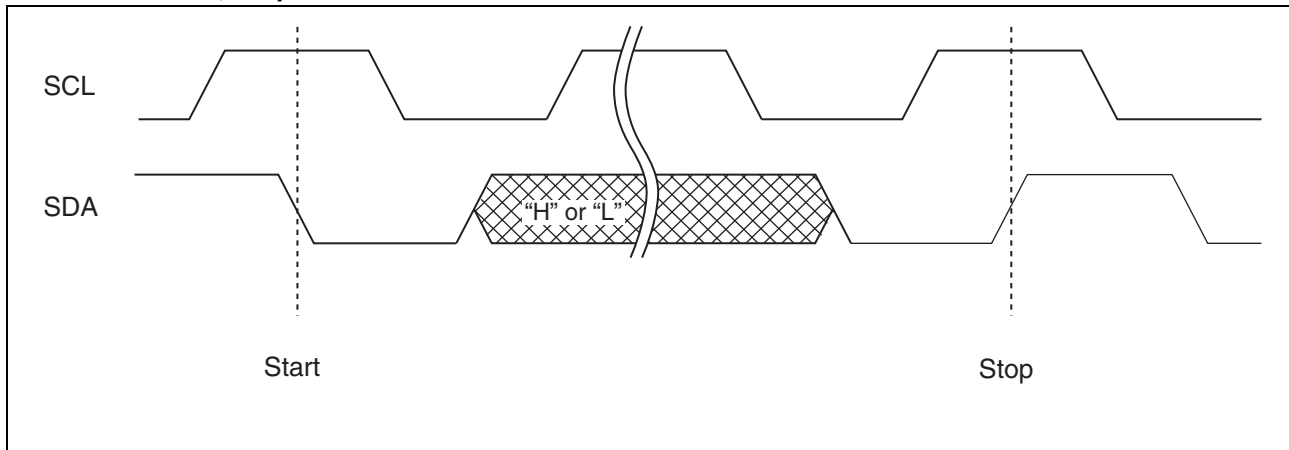

Note : At the write operation, the FRAM device does not need the programming wait time (t_{wc}) after issuing the Stop Condition.

■ ACKNOWLEDGE (ACK)

In the I²C bus, serial data including memory address or memory information is sent and received in units of 8 bits. The acknowledge signal indicates that every 8 bits of the data is successfully sent and received. The receiver side usually outputs the “L” level every time on the 9th SCL clock after each 8 bits are successfully transmitted and received. On the transmitter side, the bus is temporarily released to Hi-Z every time on this 9th clock to allow the acknowledge signal to be received and checked. During this Hi-Z released period, the receiver side pulls the SDA line down to indicate the “L” level that the previous 8 bits communication is successfully received.

In case the slave side receives Stop condition before sending or receiving the ACK “L” level, the slave side stops the operation and enters to the standby state. On the other hand, the slave side releases the bus state after sending or receiving the NACK “H” level. The master side generates Stop condition or Start condition in this released bus state.

• Acknowledge timing overview diagram

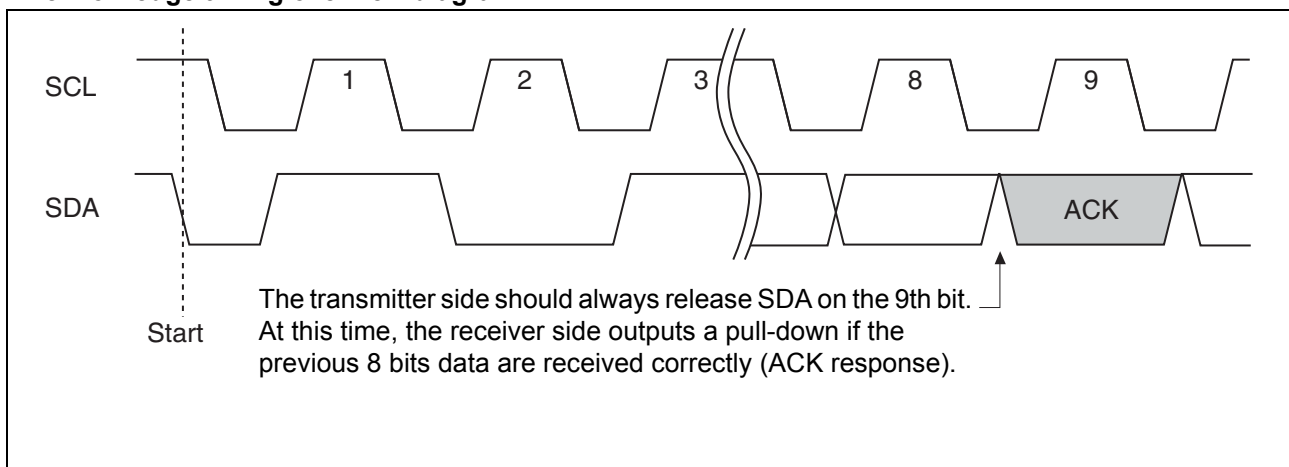

■ MEMORY ADDRESS STRUCTURE

The MB85RC16V has the memory address buffer to store the 11-bit information for the memory address.

As for byte write, page write and random read commands, the complete 11-bit memory address is configured by inputting the memory upper address (3 bits) and the memory lower address (8 bits), and saved to the memory address buffer. Then access to the memory is performed.

As for a current address read command, the complete 11-bit memory address is configured and saved to the memory address buffer, by inputting the memory upper address (3 bits) and the memory lower address (8 bits) which has saved in the memory address buffer. Then access to the memory is performed.

MB85RC16V

■ DEVICE ADDRESS WORD

Following the start condition, the 8 bit device address word is input. Inputting the device address word decides whether writing or reading operation. However, the clock is always driven by the master. The device address word (8 bits) consists of a device Type code (4 bits), memory upper address code (3 bits), and a Read/Write code (1 bit).

- Device Type Code (4 bits)

The upper 4 bits of the device address word are a device type code that identifies the device type, and are fixed at "1010" for the MB85RC16V.

- Memory Upper Address Code (3 bits)

Following the device type code, the 3 bits of the memory upper address code are input.

The slave address selection is not performed by the external pin setting on this device. These 3 bits are not the setting bits for the slave address, but the upper 3-bit setting bits for the memory address.

- Read/Write Code (1 bit)

The 8th bit of the device address word is the R/W (Read/Write) code. When the R/W code is "0" input, a write operation is enabled, and the R/W code is "1" input, a read operation is enabled for the MB85RC16V. If the device code is not "1010", the Read/Write operation is not performed and the standby state is chosen.

• Device Address Word

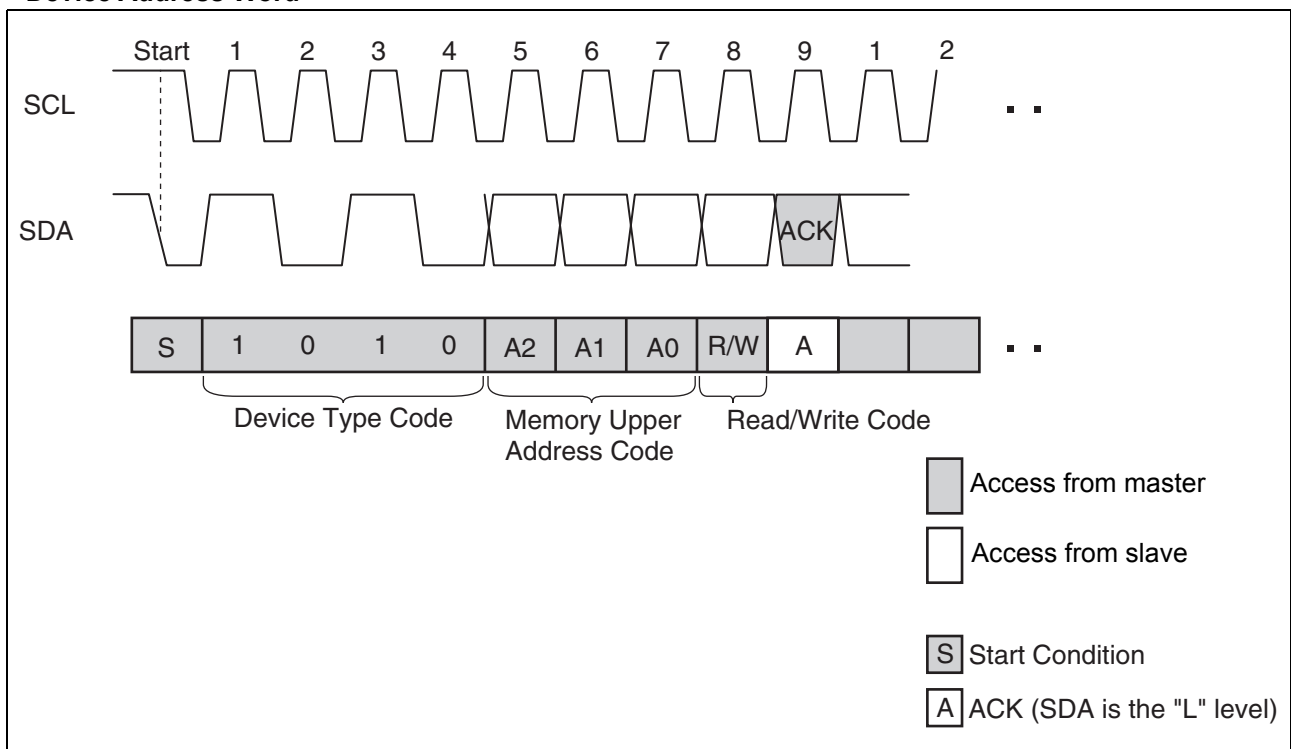

■ DATA STRUCTURE

The master inputs the device address word (8 bits) following the start condition, and then the slave outputs the Acknowledge “L” level on the 9th bit. After confirming the Acknowledge response, the sequential 8-bit memory lower address is input, to the byte write, page write and random read commands.

As for the current address read command, inputting the memory lower address is not performed, and the address buffer lower 8-bit is used as the memory lower address.

When inputting the memory lower address is finished, the slave outputs the Acknowledge “L” level on the 9th bit again.

Afterwards, the input and the output data continue in 8-bit units, and then the Acknowledge “L” level is output for every 8-bit data.

■ FRAM ACKNOWLEDGE -- POLLING NOT REQUIRED

The MB85RC16V performs the high speed write operations, so any waiting time for an ACK* by the acknowledge polling does not occur.

*: In E²PROM, the Acknowledge Polling is performed as a progress check whether rewriting is executed or not. It is normal to judge by the 9th bit of Acknowledge whether rewriting is performed or not after inputting the start condition and then the device address word (8 bits) during rewriting.

■ WRITE PROTECT (WP)

The entire memory array can be write protected by setting the WP pin to the “H” level. When the WP pin is set to the “L” level, the entire memory array will be rewritten. Reading is allowed regardless of the WP pin's “H” level or “L” level.

Do not change the WP signal level during the communication period from the start condition to the stop condition.

Note : The WP pin is pulled down internally to the VSS pin, therefore if the WP pin is open, the pin status is recognized as the “L” level (write enabled).

MB85RC16V

■ COMMAND

• Byte Write

If the device address word (R/W "0" input) is sent after the start condition, the slave responds with an ACK. After this ACK, write memory addresses and write data are sent in the same way, and the write ends by generating a stop condition at the end.

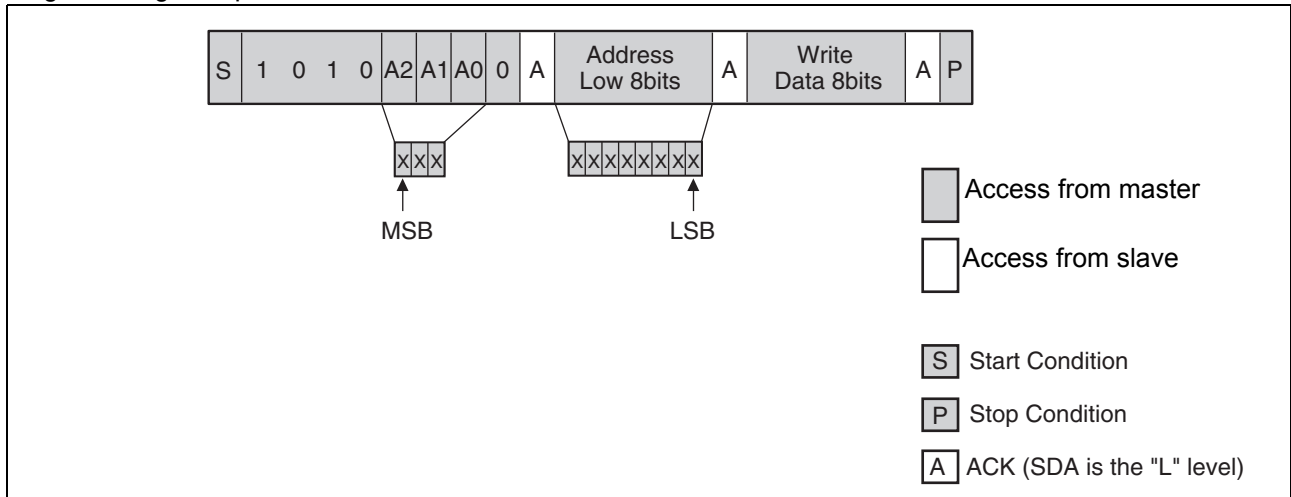

• Page Write

If additional 8 bits are continuously sent after the same command (except stop condition) as Byte Write, a page write is performed. The memory address rolls over to first memory address (000_H) at the end of the address. Therefore, if more than 2 Kbytes are sent, the data is overwritten in order starting from the start of the memory address that was written first.

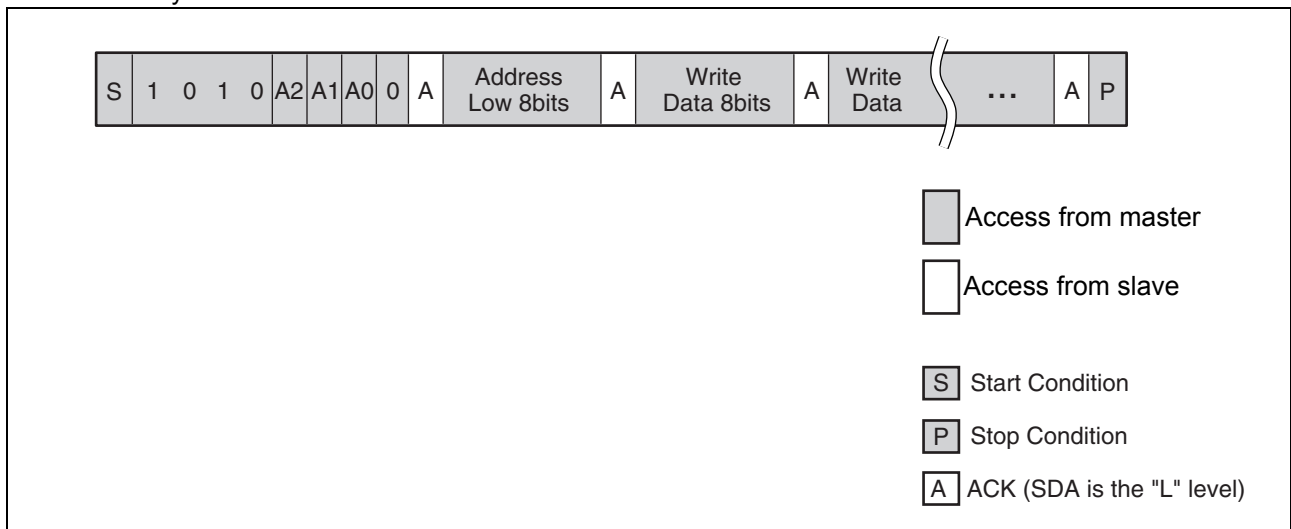

• Current Address Read

If the last write or read operation finishes successfully up to the end of stop condition, the memory address that was accessed last remains in the memory address buffer (the length is 11 bits).

When sending this command without turning the power off, it is possible to read from the memory address n+1 which adds 1 to the total 11-bit memory address n, which consists of the memory upper address 3-bit from the device address word input and the lower 8-bit of the memory address buffer. If the memory address n is the last address, it is possible to read with rolling over to the head of the memory address (000_H). The current address (address that the memory address buffer indicates) is undefined immediately after turning the power on.

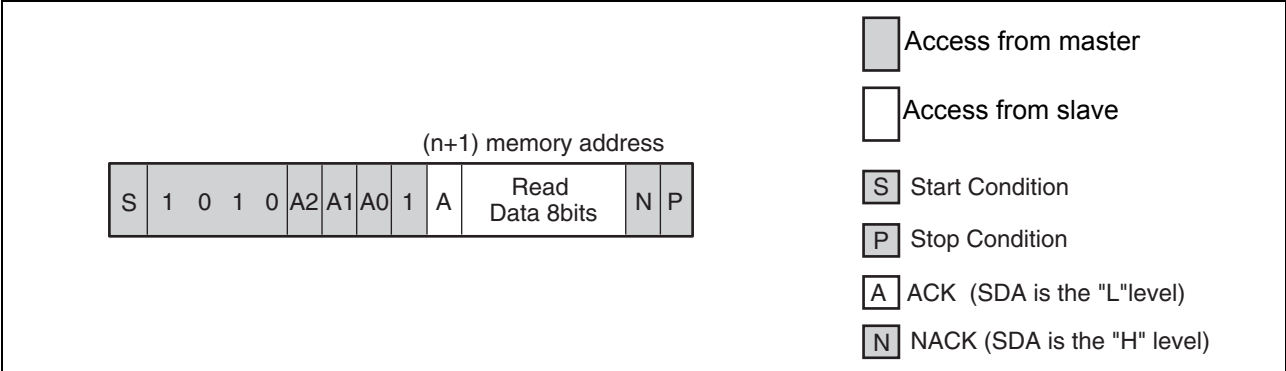

• Random Read

The one byte of data from the memory address saved in the memory address buffer can be read out synchronously to SCL by specifying the address in the same way as for a write, and then issuing another start condition and sending the Device Address Word (R/W "1" input).

Setting values for the first and the second memory upper address codes should be the same (an example is shown in below).

The final NACK (SDA is the "H" level) is issued by the receiver that receives the data. In this case, this bit is issued by the master side.

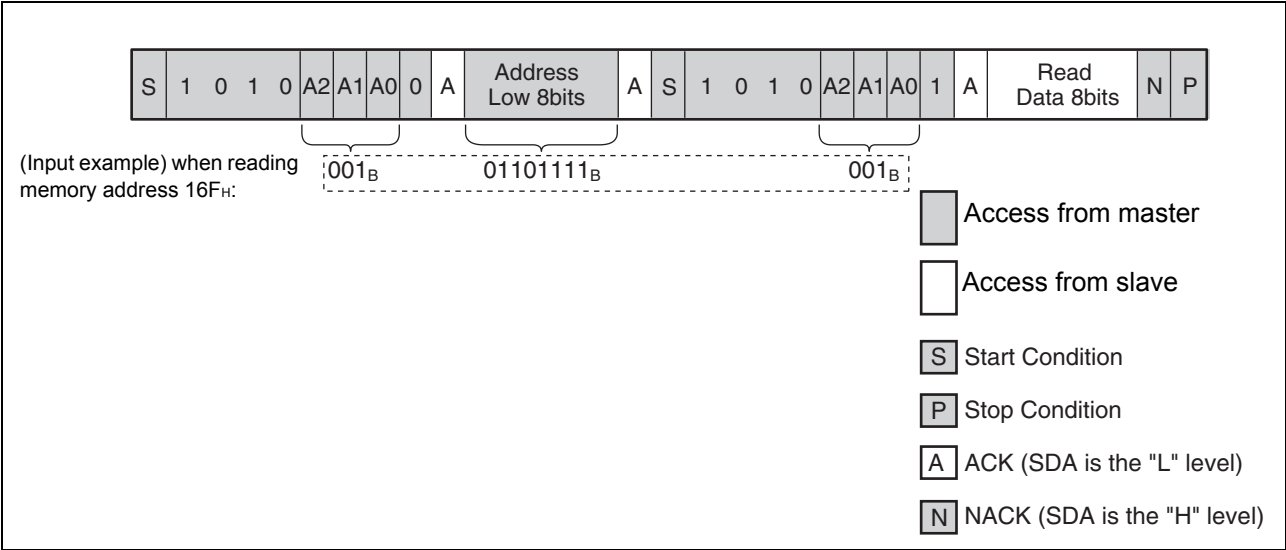

- Sequential Read

Data can be received continuously following the Device address word (R/W "1" input) after specifying the address in the same way as for Random Read. If the read reaches the end of address, the read address automatically rolls over to the first memory address (000_H) and keeps reading.

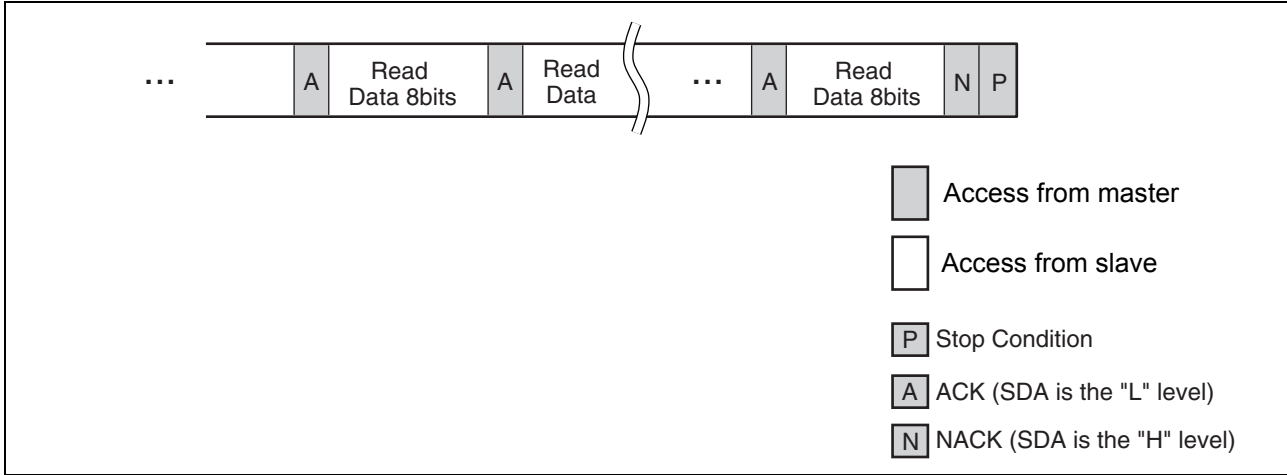

■ SOFTWARE RESET SEQUENCE OR COMMAND RETRY

In case the malfunction has occurred after power on, the master side stopped the I²C communication during processing, or unexpected malfunction has occurred, execute the following (1) software recovery sequence just before each command, or (2) retry command just after failure of each command.

(1) Software Reset Sequence

Since the slave side may be outputting "L" level, do not force to drive "H" level, when the master side drives the SDA port. This is for preventing a bus conflict. The additional hardware is not necessary for this software reset sequence.

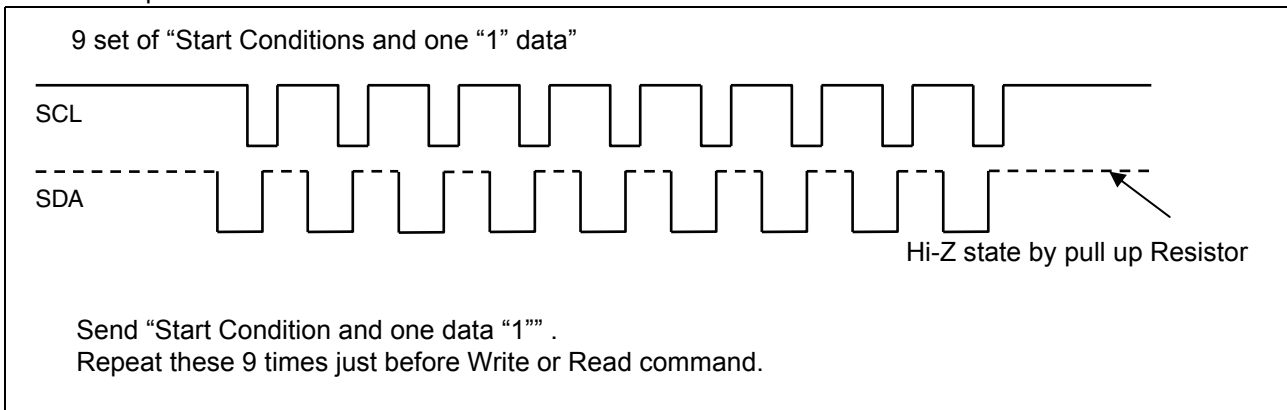

(2) Command Retry

Command retry is useful to recover from failure response during I²C communication.

■ ABSOLUTE MAXIMUM RATINGS

Parameter	Symbol	Rating		Unit
		Min	Max	
Power supply voltage*	V_{DD}	- 0.5	+ 6.0	V
Input voltage*	V_{IN}	- 0.5	$V_{DD} + 0.5 (\leq 6.0)$	V
Output voltage*	V_{OUT}	- 0.5	$V_{DD} + 0.5 (\leq 6.0)$	V
Operation ambient temperature	T_A	- 40	+ 85	°C
Storage temperature	T_{STG}	- 55	+ 125	°C

*: These parameters are based on the condition that V_{SS} is 0 V.

WARNING: Semiconductor devices can be permanently damaged by application of stress (voltage, current, temperature, etc.) in excess of absolute maximum ratings. Do not exceed these ratings.

■ RECOMMENDED OPERATING CONDITIONS

Parameter	Symbol	Value			Unit
		Min	Typ	Max	
Power supply voltage ^{*1}	V_{DD}	3.0	—	5.5	V
Operation ambient temperature ^{*2}	T_A	- 40	—	+ 85	°C

*1: These parameters are based on the condition that V_{SS} is 0 V.

*2: Ambient temperature when only this device is working. Please consider it to be the almost same as the package surface temperature.

WARNING: The recommended operating conditions are required in order to ensure the normal operation of the semiconductor device. All of the device's electrical characteristics are warranted when the device is operated within these ranges.

Always use semiconductor devices within their recommended operating condition ranges. Operation outside these ranges may adversely affect reliability and could result in device failure. No warranty is made with respect to uses, operating conditions, or combinations not represented on the data sheet. Users considering application outside the listed conditions are advised to contact their representatives beforehand.

■ ELECTRICAL CHARACTERISTICS

1. DC Characteristics

(within recommended operating conditions)

Parameter	Symbol	Condition	Value			Unit
			Min	Typ	Max	
Input leakage current*1	I _{LI}	V _{IN} = 0 V to V _{DD}	—	—	1	μA
Output leakage current*2	I _{LO}	V _{OUT} = 0 V to V _{DD}	—	—	1	μA
Operating power supply current	I _{DD}	SCL = 400 kHz	—	40	80	μA
		SCL = 1000 kHz	—	90	130	μA
Standby current	I _{SB}	SCL, SDA = V _{DD} WP = 0 V or V _{DD} or OPEN T _A = +25 °C in stop condition	—	5	10	μA
"H" level input voltage	V _{IH}	V _{DD} = 3.0 V to 5.5 V	V _{DD} × 0.8	—	5.5	V
"L" level input voltage	V _{IL}	V _{DD} = 3.0 V to 5.5 V	V _{SS}	—	V _{DD} × 0.2	V
"L" level output voltage	V _{OL}	I _{OL} = 3 mA	—	—	0.4	V
Input resistance for WP pin	R _{IN}	V _{IN} = V _{IL} (Max)	50	—	—	kΩ
		V _{IN} = V _{IH} (Min)	1	—	—	MΩ

*1: Applicable pin: SCL,SDA

*2: Applicable pin: SDA

2. AC Characteristics

Parameter	Symbol	Value						Unit
		STANDARD MODE		FAST MODE		FAST MODE PLUS		
		Min	Max	Min	Max	Min	Max	
SCL clock frequency	FSCL	0	100	0	400	0	1000	kHz
Clock high time	T _{HIGH}	4000	—	600	—	400	—	ns
Clock low time	T _{LOW}	4700	—	1300	—	600	—	ns
SCL/SDA rising time	T _r	—	1000	—	300	—	300	ns
SCL/SDA falling time	T _f	—	300	—	300	—	100	ns
Start condition hold	T _{HD:STA}	4000	—	600	—	250	—	ns
Start condition setup	T _{SU:STA}	4700	—	600	—	250	—	ns
SDA input hold	T _{HD:DAT}	20	—	20	—	20	—	ns
SDA input setup	T _{SU:DAT}	250	—	100	—	100	—	ns
SDA output hold	T _{DH:DAT}	0	—	0	—	0	—	ns
Stop condition setup	T _{SU:STO}	4000	—	600	—	250	—	ns
SDA output access after SCL falling	T _{AA}	—	3000	—	900	—	550	ns
Pre-charge time	T _{BUF}	4700	—	1300	—	500	—	ns
Noise suppression time (SCL and SDA)	T _{SP}	—	50	—	50	—	50	ns

AC characteristics were measured under the following measurement conditions.

Power supply voltage : STANDARD MODE and FAST MODE 3.0 V to 5.5 V
: FAST MODE PLUS 4.5 V to 5.5 V

Operation ambient temperature: - 40 °C to + 85 °C

Input voltage amplitude: V_{DD} × 0.2 to V_{DD} × 0.8

Input rising time : 5 ns

Input falling time : 5 ns

Input judge level : V_{DD}/2

Output judge level : V_{DD}/2

3. AC Timing Definitions

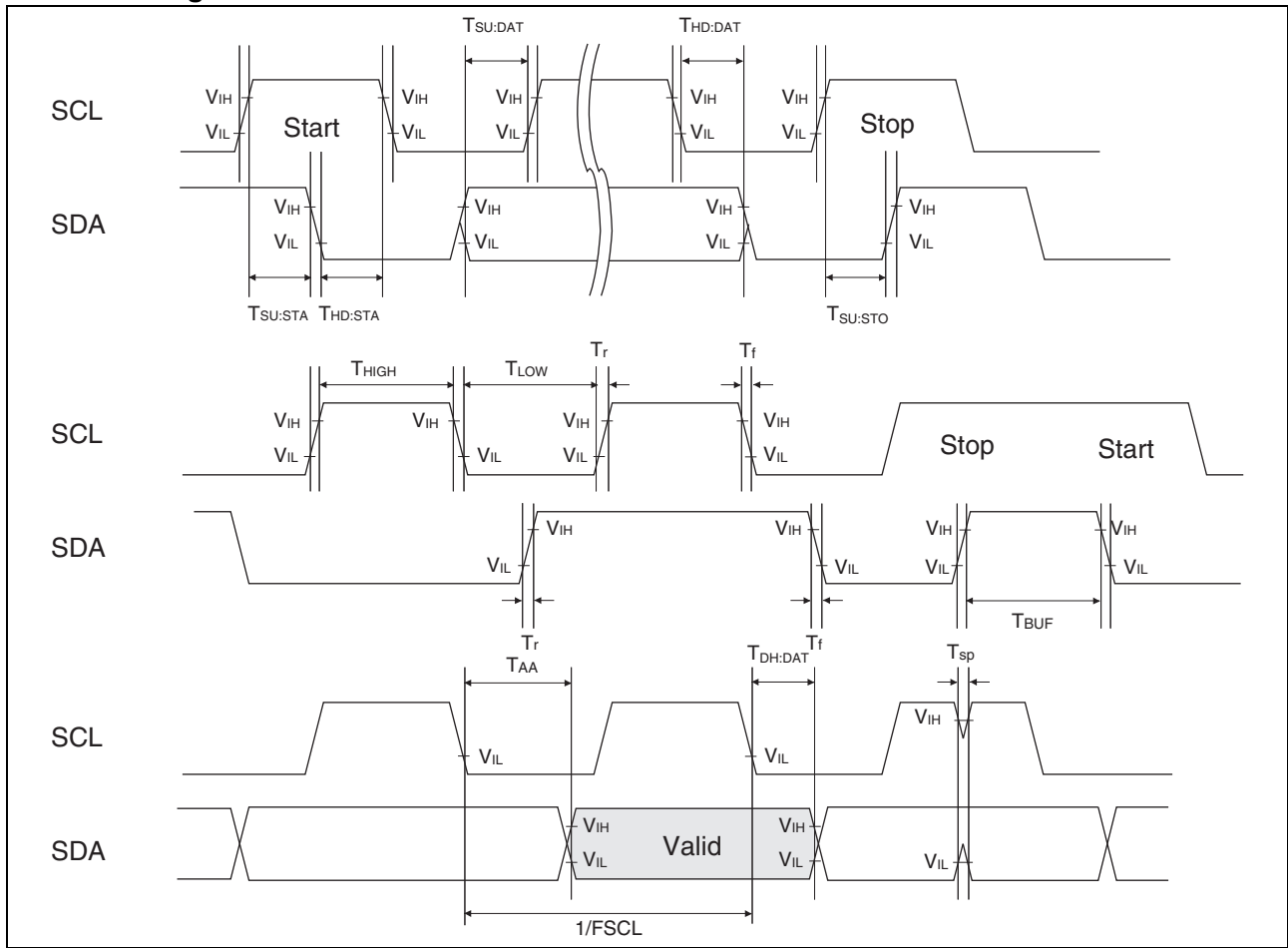

4. Pin capacitance

Parameter	Symbol	Conditions	Value			Unit
			Min	Typ	Max	
I/O capacitance	$C_{I/O}$	$V_{DD} = V_{IN} = V_{OUT} = 0V$, $f = 1 \text{ MHz}$, $T_A = +25^\circ\text{C}$	—	—	15	pF
Input capacitance	C_{IN}		—	—	15	pF

5. AC Test Load Circuit

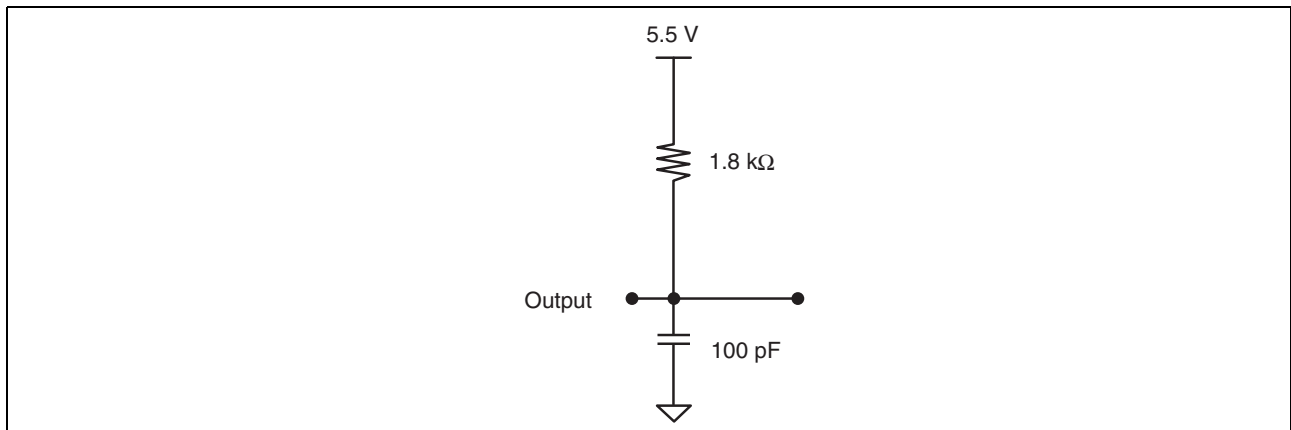

■ POWER ON/OFF SEQUENCE

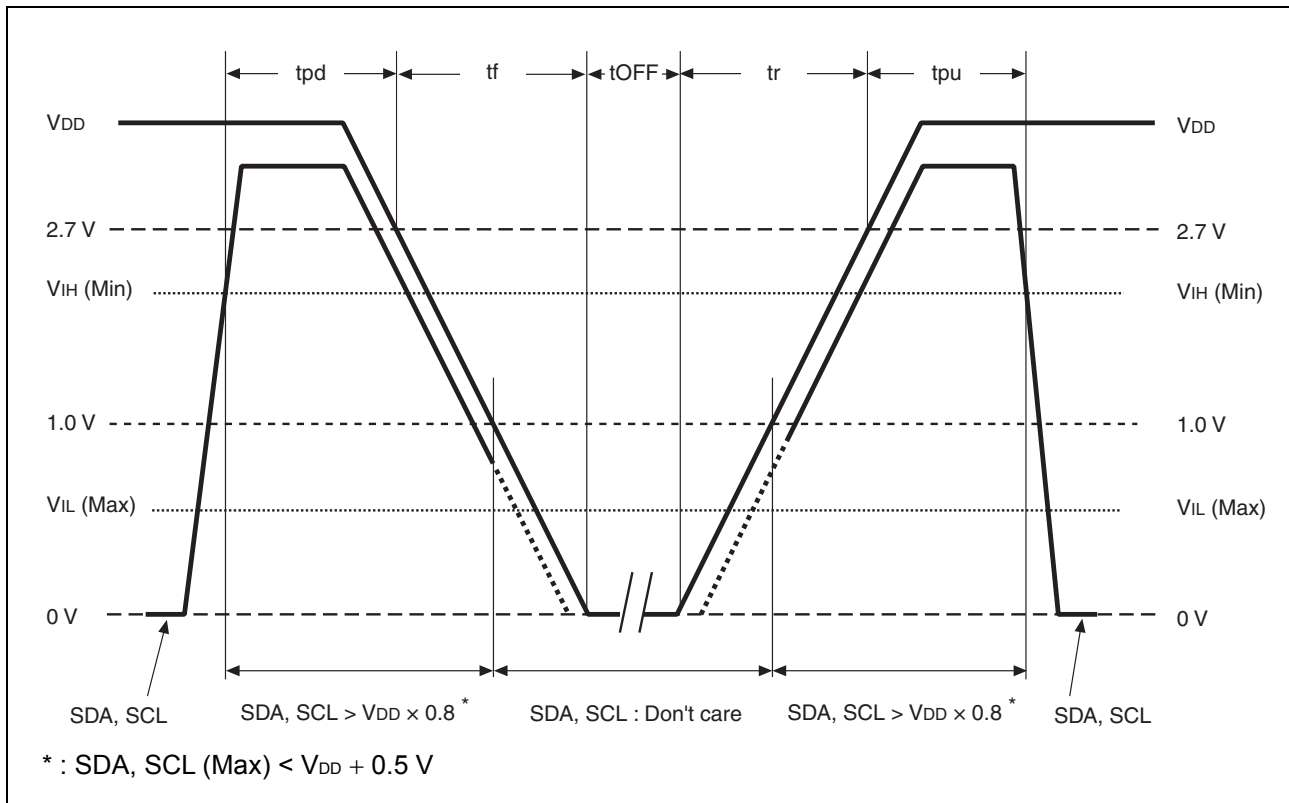

Parameter	Symbol	Value		Unit	Condition
		Min	Max		
SDA, SCL level hold time during power down	tpd	85	—	ns	—
SDA, SCL level hold time during power up	tpu	85	—	ns	$V_{DD} = 5.0V \pm 0.5V$ Operation
		0.5	—	ms	$V_{DD} = 3.3V \pm 0.3V$ Operation
Power supply rising time	tr	0.5	50	ms	$V_{DD} = 5.0V \pm 0.5V$ Operation
		0.005	50		$V_{DD} = 3.3V \pm 0.3V$ Operation
Power supply falling time	tf	0.01	50	ms	—
Power off time	tOFF	50	—	ms	—

If the device does not operate within the specified conditions of read cycle, write cycle or power on/off sequence, memory data can not be guaranteed.

■ FRAM CHARACTERISTICS

Item	Min	Max	Unit	Parameter
Read/Write Endurance*1	10^{12}	—	Times/byte	Operation Ambient Temperature $T_A = +85^\circ\text{C}$
Data Retention*2	10	—	Years	Operation Ambient Temperature $T_A = +85^\circ\text{C}$
	95	—		Operation Ambient Temperature $T_A = +55^\circ\text{C}$
	≥ 200	—		Operation Ambient Temperature $T_A = +35^\circ\text{C}$

*1 : Total number of reading and writing defines the minimum value of endurance, as an FRAM memory operates with destructive readout mechanism.

*2 : Minimum values define retention time of the first reading/writing data right after shipment, and these values are calculated by qualification results.

MB85RC16V

■ NOTE ON USE

We recommend programming of the device after reflow. Data written before reflow cannot be guaranteed.

■ ESD AND LATCH-UP

Test	DUT	Value
ESD HBM (Human Body Model) JESD22-A114 compliant	MB85RC16VPNF-G-JNN1E1	$\geq 2000 \text{ V} $
ESD MM (Machine Model) JESD22-A115 compliant		$\geq 200 \text{ V} $
ESD CDM (Charged Device Model) JESD22-C101 compliant		$\geq 1000 \text{ V} $
Latch-Up (I-test) JESD78 compliant		—
Latch-Up (V_{supply} overvoltage test) JESD78 compliant		—
Latch-Up (Current Method) Proprietary method		$\geq 300 \text{ mA} $
Latch-Up (C-V Method) Proprietary method		—

- Current method of Latch-Up Resistance Test

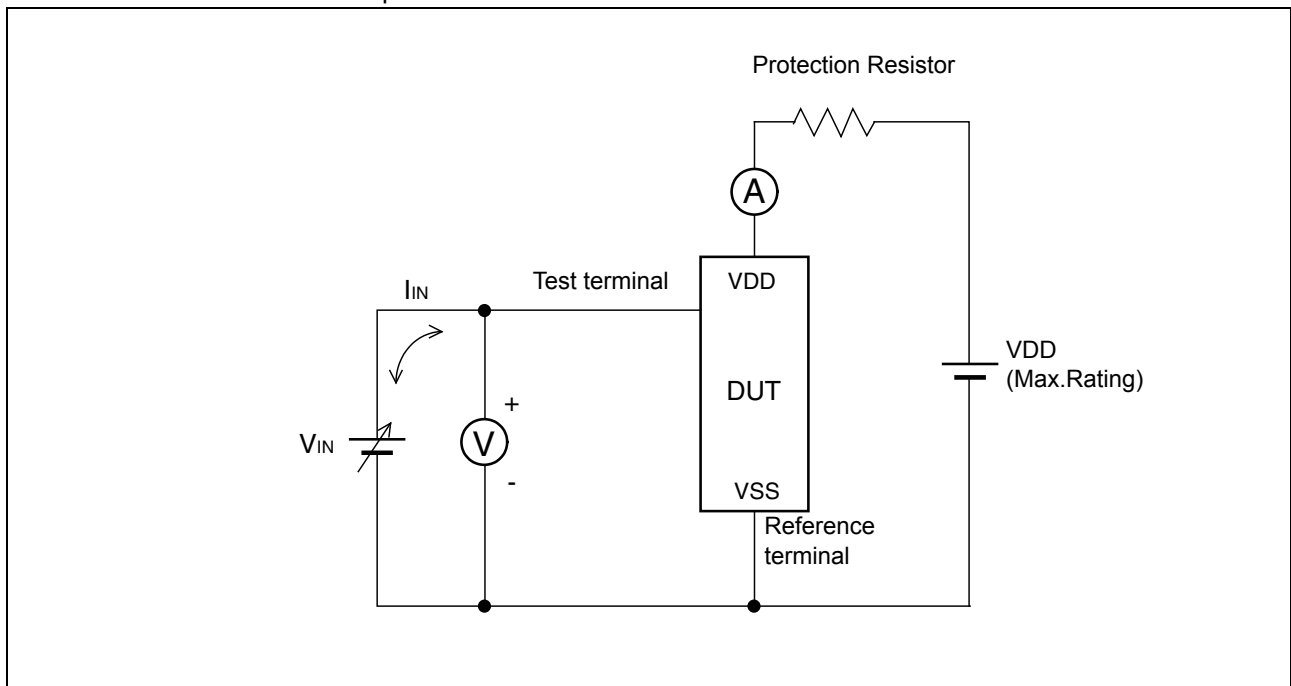

Note : The voltage V_{IN} is increased gradually and the current I_{IN} of 300 mA at maximum shall flow.

Confirm the latch up does not occur under $I_{IN} = \pm 300 \text{ mA}$.

In case the specific requirement is specified for I/O and I_{IN} cannot be 300 mA, the voltage shall be increased to the level that meets the specific requirement.

• C-V method of Latch-Up Resistance Test

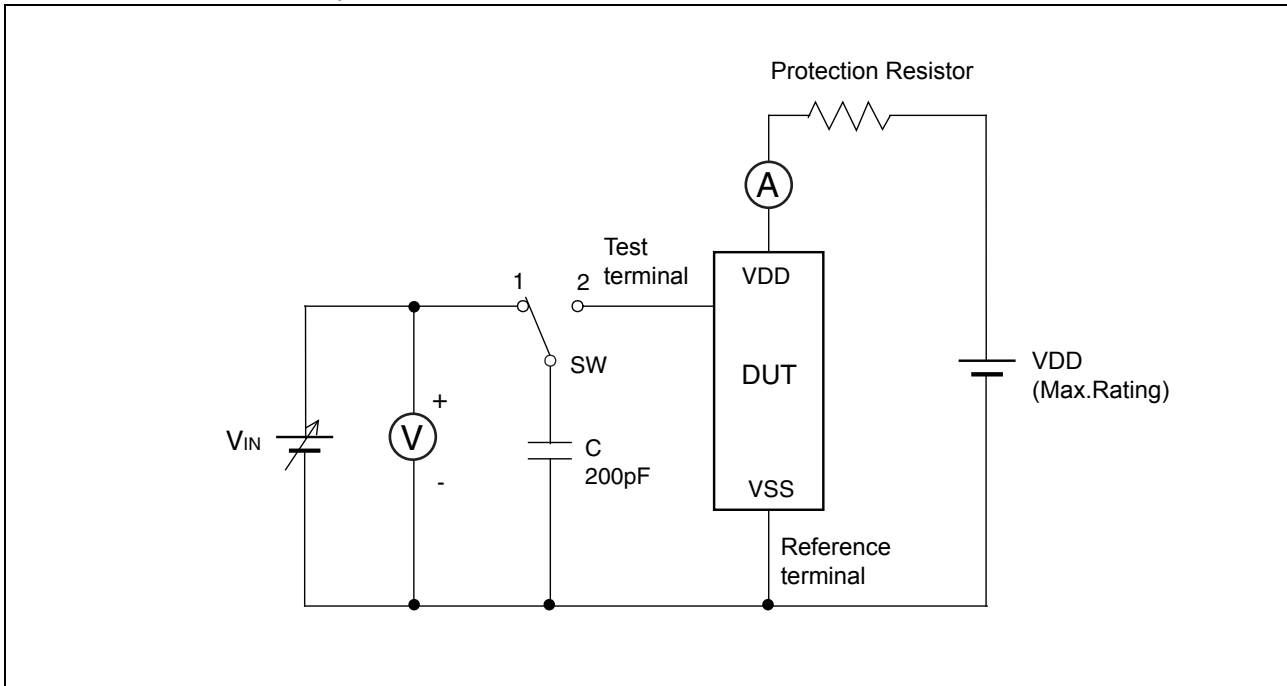

Note : Charge voltage alternately switching 1 and 2 approximately 2 sec interval. This switching process is considered as one cycle.
Repeat this process 5 times. However, if the latch-up condition occurs before completing 5 times, this test must be stopped immediately.

■ REFLOW CONDITIONS AND FLOOR LIFE

[JEDEC MSL] : Moisture Sensitivity Level 3 (ISP/JEDEC J-STD-020D)

■ CURRENT STATUS ON CONTAINED RESTRICTED SUBSTANCES

This product complies with the regulations of REACH Regulations, EU RoHS Directive and China RoHS.

MB85RC16V

■ ORDERING INFORMATION

Part number	Package	Shipping form	Minimum shipping quantity
MB85RC16VPNF-G-JNN1E1	8-pin, plastic SOP (FPT-8P-M02)	Tube	—*1
MB85RC16VPNF-G-JNN1ERE1	8-pin, plastic SOP (FPT-8P-M02)	Embossed Carrier tape	1500

*1: Please contact our sales office about minimum shipping quantity.

■ PACKAGE DIMENSION

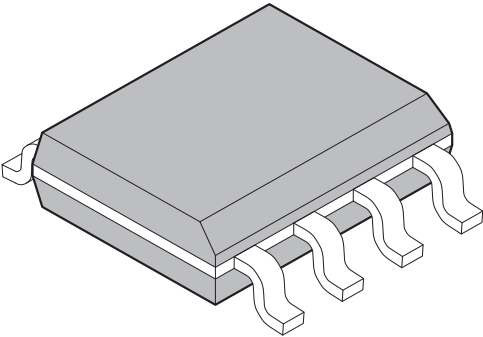
<p style="text-align: center;">8-pin plastic SOP</p>  <p style="text-align: center;">(FPT-8P-M02)</p>	Lead pitch	1.27 mm
	Package width × package length	3.9 mm × 5.05 mm
	Lead shape	Gullwing
	Sealing method	Plastic mold
	Mounting height	1.75 mm MAX
	Weight	0.06 g

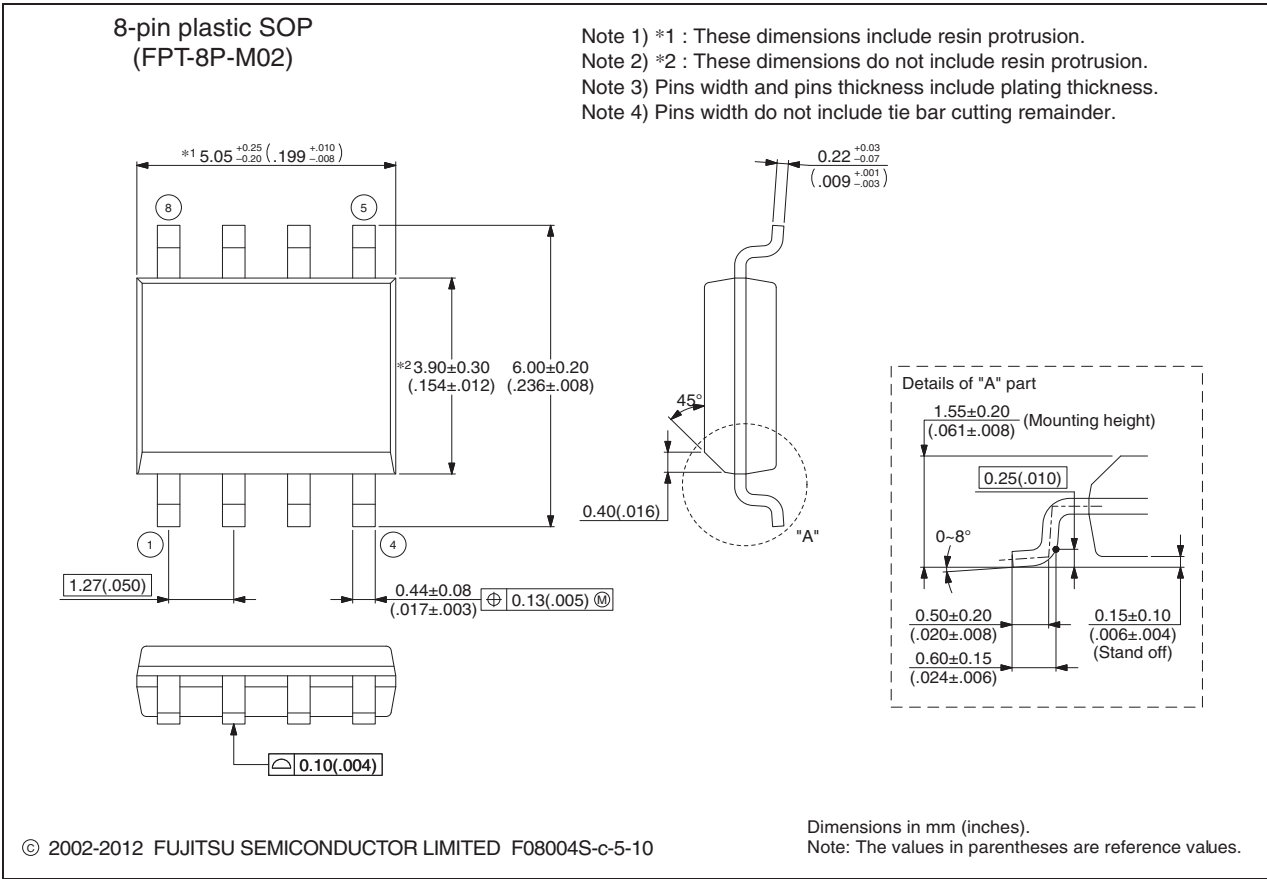

■ MARKING

[MB85RC16VPNF-G-JNN1E1]
[MB85RC16VPNF-G-JNN1ERE1]



[FPT-8P-M02]

■ PACKING INFORMATION

1. Tube

1.1 Tube Dimensions

- Tube/stopper shape

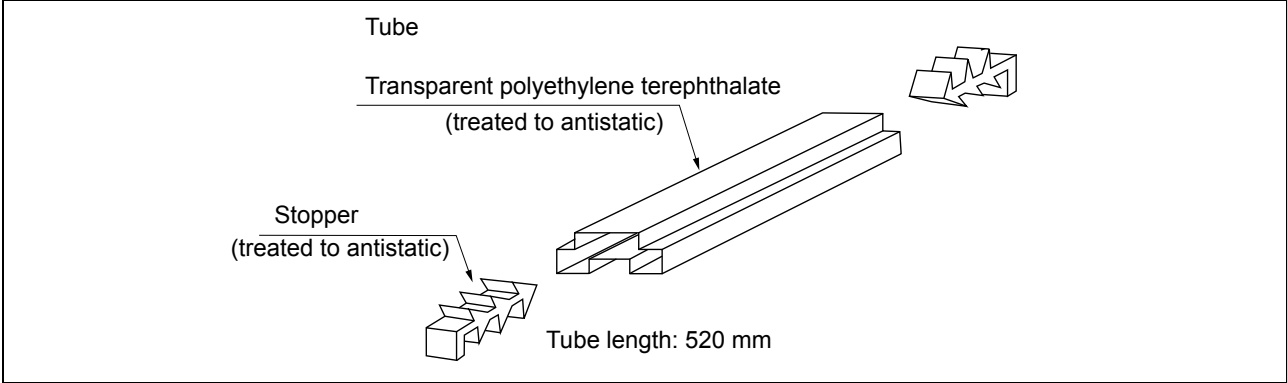

Tube cross-sections and Maximum quantity

Package form	Package code	Maximum quantity		
		pcs/ tube	pcs/inner box	pcs/outer box
SOP, 8, plastic (2) ©2006-2010 FUJITSU SEMICONDUCTOR LIMITED F08008-SET1-PET:FJ99L-0022-E0008-1-K-3 $t = 0.5$ Transparent polyethylene terephthalate	FPT-8P-M02	95	7600	30400

(Dimensions in mm)

MB85RC16V

1.2 Tube Dry pack packing specifications

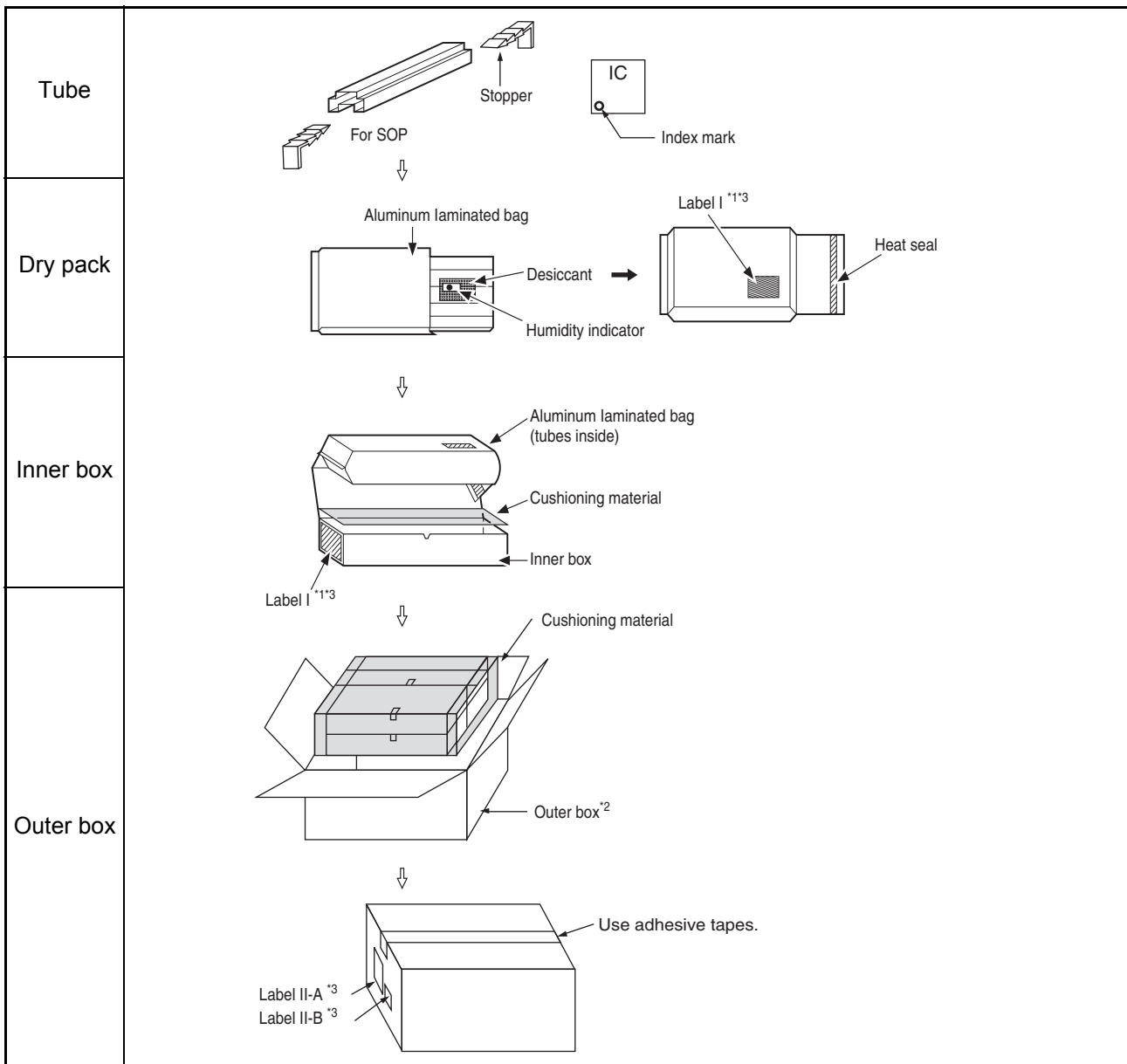

*1: For a product of which part number is suffixed with "E1", a "G" and "P" marks is display to the moisture barrier bag and the inner boxes.

*2: The space in the outer box will be filled with empty inner boxes, or cushions, etc.

*3: Please refer to an attached sheet about the indication label.

Note: The packing specifications may not be applied when the product is delivered via a distributor.

1.3 Product label indicators

Label I: Label on Inner box/Moisture Barrier Bag/ (It sticks it on the reel for the emboss taping)
 [C-3 Label (50mm × 100mm) Supplemental Label (20mm × 100mm)]

XXXXXXXXXXXXXXXX (Customer part number or FJ part number) (3N)1 XXXXXXXXXXXXXXXX XXX (LEAD FREE mark) (Part number and quantity) QC PASS (3N)2 XXXXXXXXXXXXXXXX XXXXXXXX (FJ control number) XXX pcs (Quantity) XXXXXXXXXXXXXXXX (Customer part number or FJ part number) XXXXXXXXXXXXXXXX (Customer part number or FJ part number bar code) XXXX/XX/XX (Packed years/month/day) ASSEMBLED IN xxxx XXXXXXXXXXXXXXXX (Customer part number or FJ part number) (FJ control number bar code) XX/XX (Package count) XXXX-XXX XXX XXXXXXXXXXXXXXXX (FJ control number) (Lot Number and quantity) XXXXXXXXXXXXXXXX (Comment)	← C-3 Label ← Perforated line ← Supplemental Label
--	--

Label II-A: Label on Outer box [D Label] (100mm × 100mm)

<table border="1" style="width: 100%; border-collapse: collapse;"> <tr> <td style="width: 50%; padding: 2px;"> 発注者 XXXXXXXXXXXXXXXX (Customer Name) (CUST.) </td> <td style="width: 50%; padding: 2px;"> 受注者 (VENDOR) 富士通 </td> </tr> <tr> <td style="padding: 2px;"> 受渡場所名 XXXXXXXXXXXXXXXX (Delivery Address) (DELIVERY POINT) </td> <td style="padding: 2px;"> セミコンダクター株式会社 XXX (FJ control number) </td> </tr> <tr> <td style="padding: 2px;"> 納品キー番号 XXXXXXXXXXXXXXXX (TRANS.NO.) (FJ control number) </td> <td style="padding: 2px;"> XXX (FJ control number) </td> </tr> <tr> <td style="padding: 2px;"> 品名コード XXXXXXXXXXXXXXXX (PART NO.) (Customer part number or FJ part number) </td> <td style="padding: 2px;"> XXX (FJ control number) XXXXXXXXXXXXXXXX (Part number) </td> </tr> <tr> <td colspan="2" style="padding: 2px;"> 品名 (PART NAME) XXXXXXXXXXXXXXXX (Part number) </td> </tr> <tr> <td style="padding: 2px;"> 入数/納入数量 XXX/XXX (Q'TY/TOTAL Q'TY) </td> <td style="padding: 2px;"> 単位 XX (UNIT) </td> </tr> <tr> <td style="padding: 2px;"> 発注者用備考 (CUSTOMER'S REMARKS) XXXXXXXXXXXXXXXX </td> <td style="padding: 2px;"> 梱包個数 (PACKAGE COUNT) XXX/XXX </td> </tr> </table> (3N)3 XXXXXXXXXXXXXXXX XXX (FJ control number + Product quantity) (FJ control number + Product quantity bar code) (3N)4 XXXXXXXXXXXXXXXX XXX (Part number + Product quantity) (Part number + Product quantity bar code) (3N)5 XXXXXXXXXXXXXXXX (FJ control number) (FJ control number bar code)	発注者 XXXXXXXXXXXXXXXX (Customer Name) (CUST.)	受注者 (VENDOR) 富士通	受渡場所名 XXXXXXXXXXXXXXXX (Delivery Address) (DELIVERY POINT)	セミコンダクター株式会社 XXX (FJ control number)	納品キー番号 XXXXXXXXXXXXXXXX (TRANS.NO.) (FJ control number)	XXX (FJ control number)	品名コード XXXXXXXXXXXXXXXX (PART NO.) (Customer part number or FJ part number)	XXX (FJ control number) XXXXXXXXXXXXXXXX (Part number)	品名 (PART NAME) XXXXXXXXXXXXXXXX (Part number)		入数/納入数量 XXX/XXX (Q'TY/TOTAL Q'TY)	単位 XX (UNIT)	発注者用備考 (CUSTOMER'S REMARKS) XXXXXXXXXXXXXXXX	梱包個数 (PACKAGE COUNT) XXX/XXX	← D Label
発注者 XXXXXXXXXXXXXXXX (Customer Name) (CUST.)	受注者 (VENDOR) 富士通														
受渡場所名 XXXXXXXXXXXXXXXX (Delivery Address) (DELIVERY POINT)	セミコンダクター株式会社 XXX (FJ control number)														
納品キー番号 XXXXXXXXXXXXXXXX (TRANS.NO.) (FJ control number)	XXX (FJ control number)														
品名コード XXXXXXXXXXXXXXXX (PART NO.) (Customer part number or FJ part number)	XXX (FJ control number) XXXXXXXXXXXXXXXX (Part number)														
品名 (PART NAME) XXXXXXXXXXXXXXXX (Part number)															
入数/納入数量 XXX/XXX (Q'TY/TOTAL Q'TY)	単位 XX (UNIT)														
発注者用備考 (CUSTOMER'S REMARKS) XXXXXXXXXXXXXXXX	梱包個数 (PACKAGE COUNT) XXX/XXX														

Label II-B: Outer boxes product indicate

XXXXXXXXXXXXXXXX (Part number) <table style="width: 100%; border-collapse: collapse;"> <tr> <td style="width: 33%; text-align: center;">(Lot Number)</td> <td style="width: 33%; text-align: center;">(Count)</td> <td style="width: 33%; text-align: center;">(Quantity)</td> </tr> <tr> <td style="text-align: center;">XXXX-XXX</td> <td style="text-align: center;">X 箱</td> <td style="text-align: center;">XXX 個</td> </tr> <tr> <td style="text-align: center;">XXXX-XXX</td> <td style="text-align: center;">X 箱</td> <td style="text-align: center;">XXX 個</td> </tr> <tr> <td></td> <td style="text-align: center;">計</td> <td style="text-align: center;">XXX 個</td> </tr> </table>	(Lot Number)	(Count)	(Quantity)	XXXX-XXX	X 箱	XXX 個	XXXX-XXX	X 箱	XXX 個		計	XXX 個
(Lot Number)	(Count)	(Quantity)										
XXXX-XXX	X 箱	XXX 個										
XXXX-XXX	X 箱	XXX 個										
	計	XXX 個										

Note: Depending on shipment state, "Label II-A" and "Label II-B" on the external boxes might not be printed.

MB85RC16V

1.4 Dimensions for Containers

(1) Dimensions for inner box

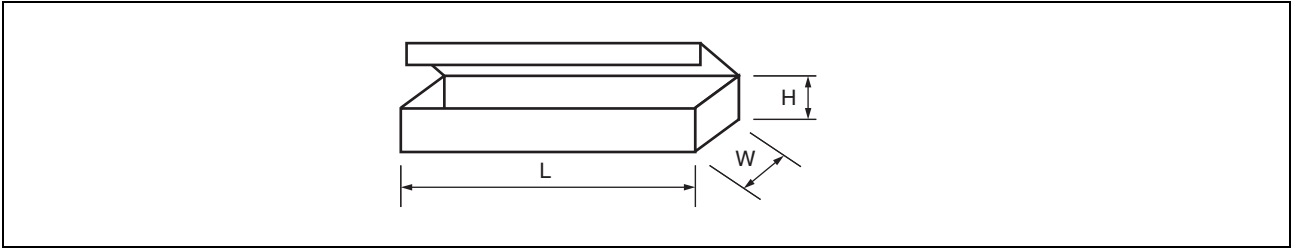

L	W	H
540	125	75

(Dimensions in mm)

(2) Dimensions for outer box

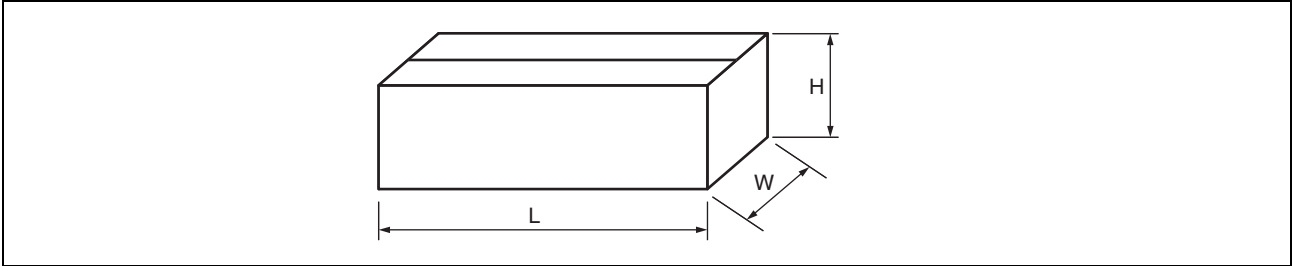

L	W	H
565	270	180

(Dimensions in mm)

2. Emboss Tape

2.1 Tape Dimensions

PKG code	Reel No	Maximum storage capacity		
		pcs/reel	pcs/inner box	pcs/outer box
FPT-8P-M02	3	1500	1500	10500

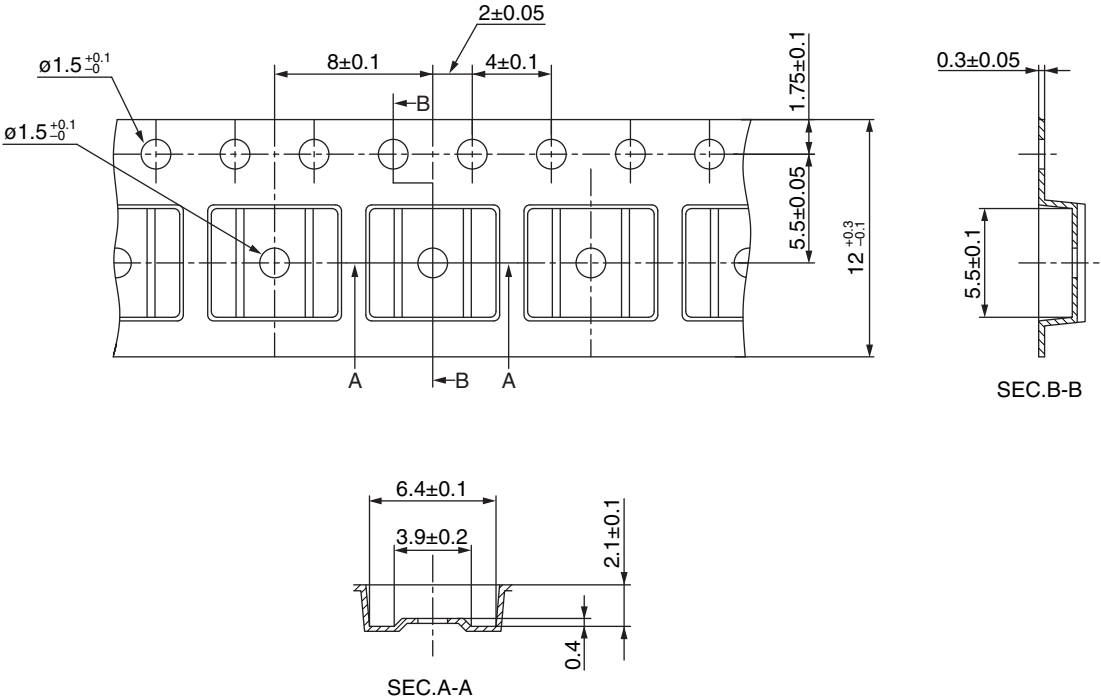

© 2012 FUJITSU SEMICONDUCTOR LIMITED SOL8-EMBOSSTAPE9 : NFME-EMB-X0084-1-P-1

(Dimensions in mm)

Material : Conductive polystyrene
 Heat proof temperature : No heat resistance.
 Package should not be baked by using tape and reel.

MB85RC16V

2.2 IC orientation

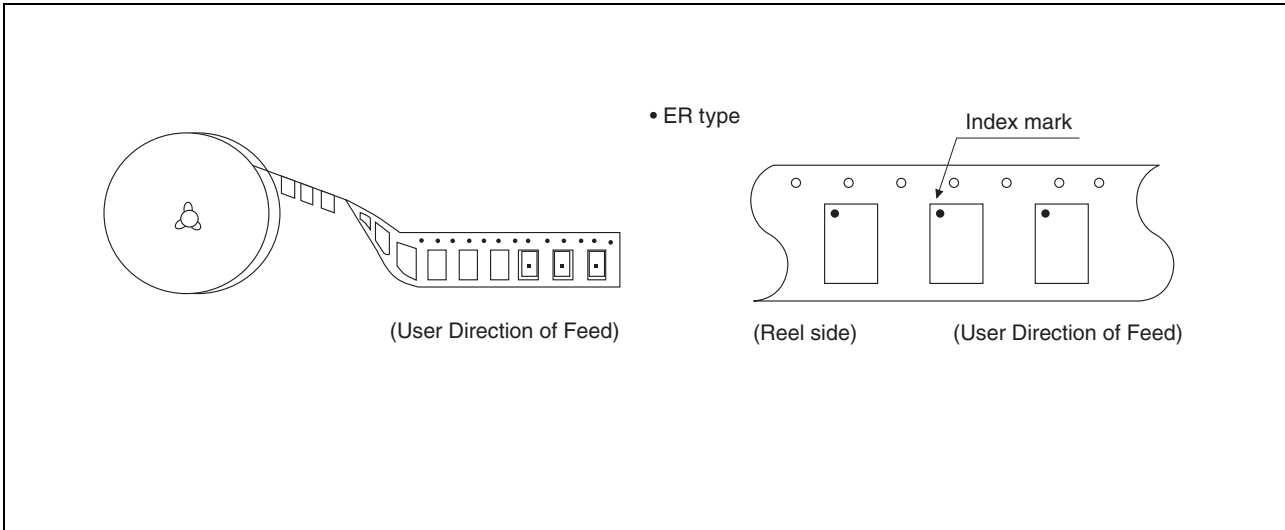

2.3 Reel dimensions

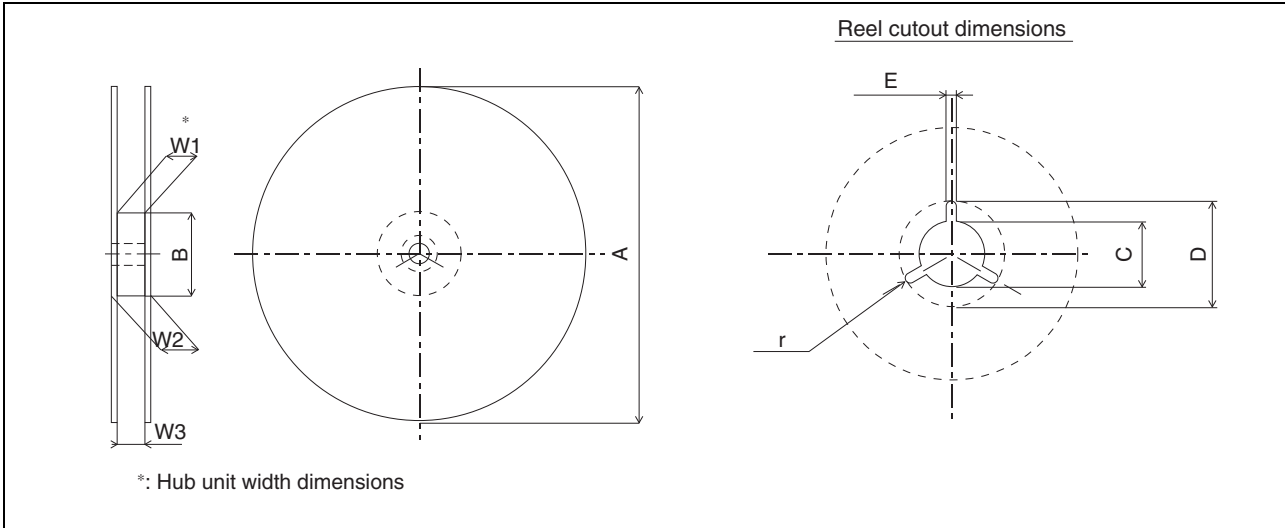

Dimensions in mm

Reel No	1	2	3	4	5	6	7	8	9	10	11	12	13	14	15
Tape width Symbol	8	12		16		24		32		44		56	12	16	24
A	254 ± 2	254 ± 2	330 ± 2	254 ± 2	330 ± 2	254 ± 2	330 ± 2	330 ± 2							
B	100 ⁺² ₋₀							100 ⁺² ₋₀	150 ⁺² ₋₀	100 ⁺² ₋₀	150 ⁺² ₋₀	100 ⁺² ₋₀	100 ± 2		
C	13 ± 0.2												13 ^{+0.5} _{-0.2}		
D	21 ± 0.8												20.5 ⁺¹ _{-0.2}		
E	2 ± 0.5														
W1	8.4 ⁺² ₋₀	12.4 ⁺² ₋₀		16.4 ⁺² ₋₀		24.4 ⁺² ₋₀		32.4 ⁺² ₋₀		44.4 ⁺² ₋₀		56.4 ⁺² ₋₀	12.4 ⁺¹ ₋₀	16.4 ⁺¹ ₋₀	24.4 ^{+0.1} ₋₀
W2	less than 14.4	less than 18.4		less than 22.4		less than 30.4		less than 38.4		less than 50.4		less than 62.4	less than 18.4	less than 22.4	less than 30.4
W3	7.9 ~ 10.9	11.9 ~ 15.4		15.9 ~ 19.4		23.9 ~ 27.4		31.9 ~ 35.4		43.9 ~ 47.4		55.9 ~ 59.4	12.4 ~ 14.4	16.4 ~ 18.4	24.4 ~ 26.4
r	1.0														

2.4 Taping (φ330mm Reel) Dry Pack Packing Specifications

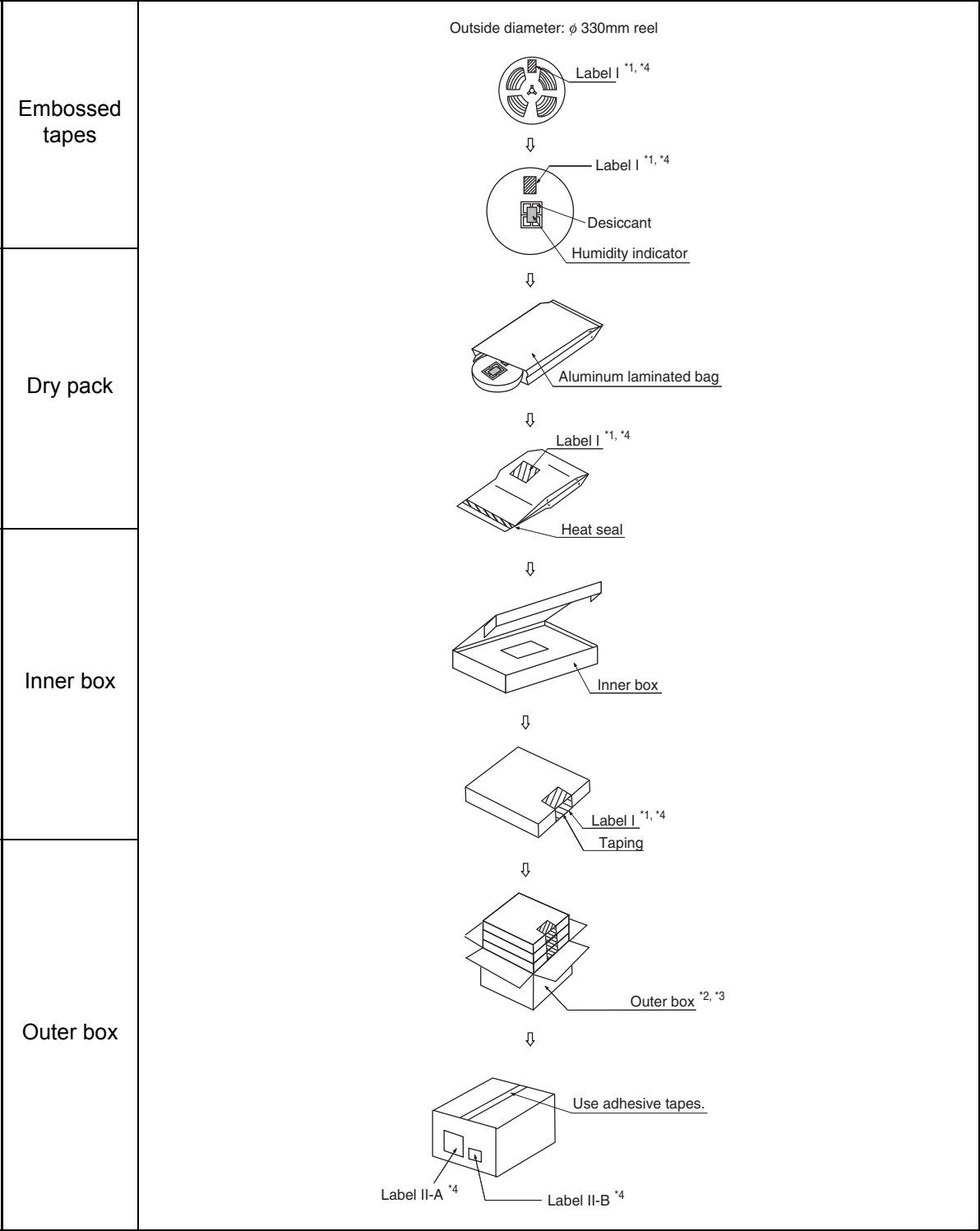

*1: For a product of witch part number is suffixed with “E1”, a “ ” marks is display to the moisture barrier bag and the inner boxes.

*2: The size of the outer box may be changed depending on the quantity of inner boxes.

*3: The space in the outer box will be filled with empty inner boxes, or cushions, etc.

*4: Please refer to an attached sheet about the indication label.

Note: The packing specifications may not be applied when the product is delivered via a distributor.

MB85RC16V

2.5 Product label indicators

Label I: Label on Inner box/Moisture Barrier Bag/ (It sticks it on the reel for the emboss taping)
 [C-3 Label (50mm × 100mm) Supplemental Label (20mm × 100mm)]

XXXXXXXXXXXXXXXX (Customer part number or FJ part number)	← C-3 Label
(3N)1 XXXXXXXXXXXXXXXX XXX (LEAD FREE mark) (Part number and quantity)	
XXXXXXXXXXXXXXXXXXXXX QC PASS	
(3N)2 XXXXXXXXXXXXXXXX XXXXXXXX (FJ control number)	
XXXXXXXXXXXXXXXXXXXXX XXX pcs (Quantity)	
XXXXXXXXXXXXXXXXXXXXX (Customer part number or FJ part number)	
XXXXXXXXXXXXXXXXXXXXX (Customer part number or FJ part number bar code)	
XXXX/XX/XX (Packed years/month/day) ASSEMBLED IN xxxx	← Perforated line
XXXXXXXXXXXXXXXXXXXXX (Customer part number or FJ part number)	← Supplemental Label
XXXXXXXXXXXXXXXXXXXXX (FJ control number bar code)	
XXXXXXXXXXXX (Package count) XXXX-XXX XXX	
XXXXXXXXXXXX (FJ control number) XXXX-XXX XXX	
XXXXXXXXXXXXXXXXXXXXX (Lot Number and quantity)	
XXXXXXXXXXXXXXXXXXXXX (Comment)	

Label II-A: Label on Outer box [D Label] (100mm × 100mm)

← D Label	
発注者 XXXXXXXXXXXXXXXX (Customer Name) (CUST.)	受注者 (VENDOR) 富士通
受渡場所名 XXXXXXXXXXXXXXXX (Delivery Address) (DELIVERY POINT)	セミコンダクター株式会社
納品キー番号 XXXXXXXXXXXXXXXX (TRANS.NO.) (FJ control number)	XXX (FJ control number)
品名コード XXXXXXXXXXXXXXXX (PART NO.) (Customer part number or FJ part number)	XXX (FJ control number)
	XXXXXXXXXXXXXXXXXXXXX (Part number)
品名 (PART NAME) XXXXXXXXXXXXXXXX (Part number)	
入数/納入数量 XXX/XXX (Q'TY/TOTAL Q'TY)	単位 XX (UNIT)
発注者用備考 (CUSTOMER'S REMARKS) XXXXXXXXXXXXXXXXXXXXX	梱包個数 (PACKAGE COUNT) XXX/XXX
(3N)3 XXXXXXXXXXXXXXXX XXX (FJ control number + Product quantity)	
XXXXXXXXXXXXXXXXXXXXX (FJ control number + Product quantity bar code)	
(3N)4 XXXXXXXXXXXXXXXX XXX (Part number + Product quantity)	
XXXXXXXXXXXXXXXXXXXXX (Part number + Product quantity bar code)	
(3N)5 XXXXXXXXXXXXXXXX (FJ control number)	
XXXXXXXXXXXXXXXXXXXXX (FJ control number bar code)	

Label II-B: Outer boxes product indicate

XXXXXXXXXXXXXXXXXXXXX (Part number)		
(Lot Number)	(Count)	(Quantity)
XXXX-XXX	X 箱	XXX 個
XXXX-XXX	X 箱	XXX 個
	計	XXX 個

Note: Depending on shipment state, "Label II-A" and "Label II-B" on the external boxes might not be printed.

2.6 Dimensions for Containers

(1) Dimensions for inner box

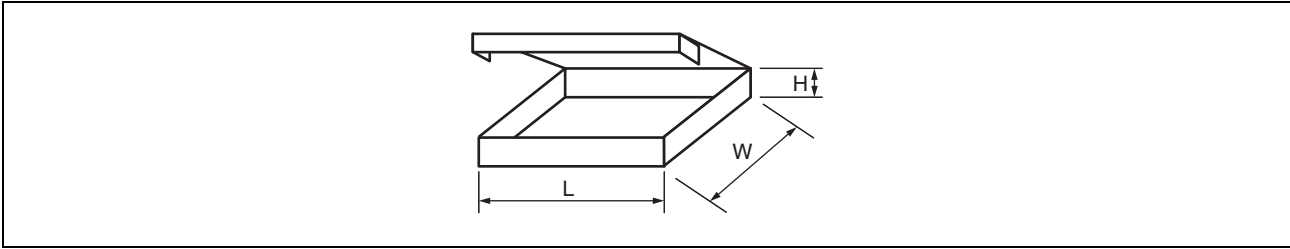

Tape width	L	W	H
12, 16	365	345	40
24, 32			50
44			65
56			75

(Dimensions in mm)

(2) Dimensions for outer box

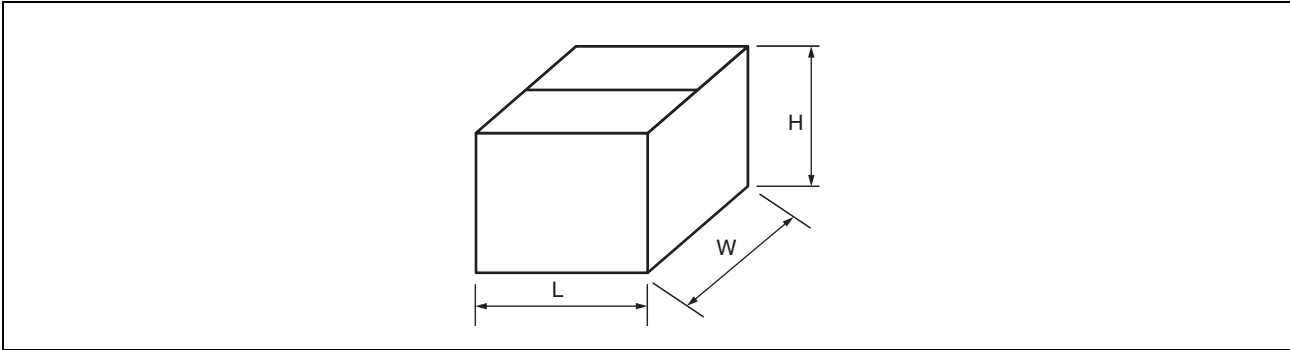

L	W	H
415	400	315

(Dimensions in mm)

■ MAJOR CHANGES IN THIS EDITION

A change on a page is indicated by a vertical line drawn on the left side of that page.

Page	Section	Change Results
18	■ ORDERING INFORMATION	Old part numbers are deleted.

FUJITSU SEMICONDUCTOR LIMITED

Shin-Yokohama Chuo Building, 2-100-45 Shin-Yokohama,
Kohoku-ku, Yokohama, Kanagawa 222-0033, Japan
<http://jp.fujitsu.com/fsl/en/>

All Rights Reserved.

FUJITSU SEMICONDUCTOR LIMITED, its subsidiaries and affiliates (collectively, "FUJITSU SEMICONDUCTOR") reserves the right to make changes to the information contained in this document without notice. Please contact your FUJITSU SEMICONDUCTOR sales representatives before order of FUJITSU SEMICONDUCTOR device.

Information contained in this document, such as descriptions of function and application circuit examples is presented solely for reference to examples of operations and uses of FUJITSU SEMICONDUCTOR device. FUJITSU SEMICONDUCTOR disclaims any and all warranties of any kind, whether express or implied, related to such information, including, without limitation, quality, accuracy, performance, proper operation of the device or non-infringement. If you develop equipment or product incorporating the FUJITSU SEMICONDUCTOR device based on such information, you must assume any responsibility or liability arising out of or in connection with such information or any use thereof. FUJITSU SEMICONDUCTOR assumes no responsibility or liability for any damages whatsoever arising out of or in connection with such information or any use thereof.

Nothing contained in this document shall be construed as granting or conferring any right under any patents, copyrights, or any other intellectual property rights of FUJITSU SEMICONDUCTOR or any third party by license or otherwise, express or implied.

FUJITSU SEMICONDUCTOR assumes no responsibility or liability for any infringement of any intellectual property rights or other rights of third parties resulting from or in connection with the information contained herein or use thereof.

The products described in this document are designed, developed and manufactured as contemplated for general use including without limitation, ordinary industrial use, general office use, personal use, and household use, but are not designed, developed and manufactured as contemplated (1) for use accompanying fatal risks or dangers that, unless extremely high levels of safety is secured, could lead directly to death, personal injury, severe physical damage or other loss (including, without limitation, use in nuclear facility, aircraft flight control system, air traffic control system, mass transport control system, medical life support system and military application), or (2) for use requiring extremely high level of reliability (including, without limitation, submersible repeater and artificial satellite). FUJITSU SEMICONDUCTOR shall not be liable for you and/or any third party for any claims or damages arising out of or in connection with above-mentioned uses of the products.

Any semiconductor devices fail or malfunction with some probability. You are responsible for providing adequate designs and safeguards against injury, damage or loss from such failures or malfunctions, by incorporating safety design measures into your facility, equipments and products such as redundancy, fire protection, and prevention of overcurrent levels and other abnormal operating conditions.

The products and technical information described in this document are subject to the Foreign Exchange and Foreign Trade Control Law of Japan, and may be subject to export or import laws or regulations in U.S. or other countries. You are responsible for ensuring compliance with such laws and regulations relating to export or re-export of the products and technical information described herein. All company names, brand names and trademarks herein are property of their respective owners.