



IGBT Modules



V_{CES} 1200V
I_c 100A

Applications

- High frequency switching application
- Medical applications
- Motion/servo control
- UPS systems

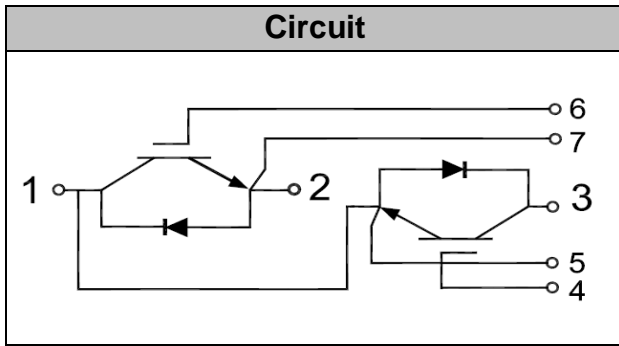

Features

- High short circuit capability, self limiting short circuit current
- IGBT CHIP (Trench+Field Stop technology)
- $V_{CE(sat)}$ with positive temperature coefficient
- Fast switching and short tail current
- Free wheeling diodes with fast and soft reverse recovery
- Low switching losses

Absolute Maximum Ratings (T_C = 25°C unless otherwise specified)

Symbol	Description	Values	Units
V _{CES}	Collector - Emitter Voltage	1200	V
V _{GES}	Gate-Emitter Voltage	±20	V
I _c	DC Collector Current	T _C =25°C	150 A
		T _C =80°C	100 A
I _{CM(1)}	Peak Collector Current Repetitive	T _J = 125°C	200 A
P _D	Maximum Power Dissipation (IGBT)	T _C = 25°C, T _{Jmax} =150°C	680 W
T _{Jmax}	Maximum Junction Temperature		150 °C
T _{JOP}	Operating Temperature		-40 ~ +150 °C
T _{stg}	Storage Temperature		-40 ~ +125 °C
Viso	Isolation Voltage (All Terminals Shorted)	f=50Hz, 1min	3000 V
Mounting Torque	Power Terminals Screw:M5		3~5 N*m
	Mounting Screw:M6		4~6 N*m

Notes :

(1) Repetitive Rating: Pulse width limited by max. junction temperature.



PRELIMINARY

MG100HF12MIC1 **RoHS**
COMPLIANT

Electrical Characteristics of IGBT ($T_J = 25^\circ\text{C}$ unless otherwise specified)

Symbol	Item	Conditions	Values			Units
			Min.	Typ.	Max.	
OFF Characteristics						
$V_{(BR)CES}$	Collector-Emitter Breakdown Voltage	$V_{GE} = 0V, I_C = 1mA$	1200			V
I_{CES}	Collector Leakage Current	$V_{CE}=V_{CES}, V_{GE}=0V,$			100	μA
		$V_{CE}=V_{CES}, V_{GE}=0V,$ $T_J=125^\circ C$			0.5	mA
I_{GES}	Gate Leakage Current	$V_{CE}=0V, V_{GE}=\pm 20V$	-400		400	nA
ON Characteristics						
$V_{GE(th)}$	Gate - Emitter Threshold Voltage	$V_{CE}=V_{GE}, I_C=4mA$	5	5.6	6.8	V
$V_{CE(sat)}$	Collector – Emitter Saturation Voltage	$I_C=100A, V_{GE}=15V$		1.7	1.9	V
		$I_C=100A, V_{GE}=15V,$ $T_J=125^\circ C$		1.9	2.1	V
Dynamic Characteristics						
C_{ies}	Input Capacitance	$V_{CE} = 25V, V_{GE} = 0V,$ $f = 100kHz$		8.3		nF
C_{oes}	Output Capacitance			0.29		nF
Switching Characteristics						
$t_{d(on)}$	Turn-on Delay Time	$V_{CC} = 600V, I_C = 10A,$ $R_G = 3.5\Omega, V_{GE} = \pm 15V,$ Inductive Load, $T_J = 25^\circ C$		118		ns
t_r	Rise Time			25		ns
$t_{d(off)}$	Turn-off Delay Time			208		ns
T_f	Fall Time			203		ns
E_{on}	Turn-on Switching Loss			2.93		mJ
E_{off}	Turn-off Switching Loss			5.62		mJ
$t_{d(on)}$	Turn-on Delay Time	$V_{CC} = 600V, I_C = 100A,$ $R_G = 3.5\Omega, V_{GE} = \pm 15V,$ Inductive Load, $T_J = 125^\circ C$		129		ns
t_r	Rise Time			27		ns
$t_{d(off)}$	Turn-off Delay Time			276		ns
T_f	Fall Time			312		ns
E_{on}	Turn-on Switching Loss			3.91		mJ
E_{off}	Turn-off Switching Loss			8.95		mJ
Q_{ge}	Gate Charge	$V_{CC}=600V, I_C=100A,$ $V_{GE}=15V$		200		nC
SCSOA	Short Circuit Safe Operating Area	$V_{CC} = 600V, V_{GE} \leq 15V,$ $T_J = 125^\circ C$	10			μs
				436		A

**Electrical Characteristics of FWD** ($T_C = 25^\circ\text{C}$ unless otherwise specified)

Symbol	Item	Conditions	Values			Units
			Min.	Typ.	Max.	
V_{FM}	Forward Voltage	$I_F = 100\text{A}$, $V_{GE} = 0\text{V}$	$T_J = 25^\circ\text{C}$	1.72	1.9	V
			$T_J = 125^\circ\text{C}$	1.82	2.1	
t_{rr}	Reverse Recovery Time	$I_F = 100\text{A}$, $di/dt = 3900\text{A}/\mu\text{s}$, $V_{rr} = 600\text{V}$, $V_{GE} = -15\text{V}$	$T_J = 25^\circ\text{C}$	110		ns
			$T_J = 125^\circ\text{C}$	197		
I_{rr}	Peak Reverse Recovery Current	$I_F = 100\text{A}$, $di/dt = 3900\text{A}/\mu\text{s}$, $V_{rr} = 600\text{V}$, $V_{GE} = -15\text{V}$	$T_J = 25^\circ\text{C}$	108		A
			$T_J = 125^\circ\text{C}$	117		
Q_{rr}	Reverse Recovery Charge	$I_F = 100\text{A}$, $di/dt = 3900\text{A}/\mu\text{s}$, $V_{rr} = 600\text{V}$, $V_{GE} = -15\text{V}$	$T_J = 25^\circ\text{C}$	5.58		μC
			$T_J = 125^\circ\text{C}$	9.25		

Thermal Resistance Characteristics

Symbol	Description	Values			Units
		Min.	Typ.	Max.	
$R_{\theta JC}$	Junction-To-Case (IGBT Part, Per Leg)			0.17	$^\circ\text{C}/\text{W}$
$R_{\theta JC}$	Junction-To-Case (Diode Part, Per Leg)			0.4	$^\circ\text{C}/\text{W}$
$R_{\theta CS}$	Case-To-Sink (Conductive Grease Applied)			0.1	$^\circ\text{C}/\text{W}$
M_t	Power Terminals Screw:M5		3	3.15	N·m
M_s	Mounting Screw:M6		5	5.75	N·m
Weight	Weight Of Module		150	160	g



PRELIMINARY

MG100HF12MIC1 **RoHS**
COMPLIANT

Package Outline Information

CASE: C1

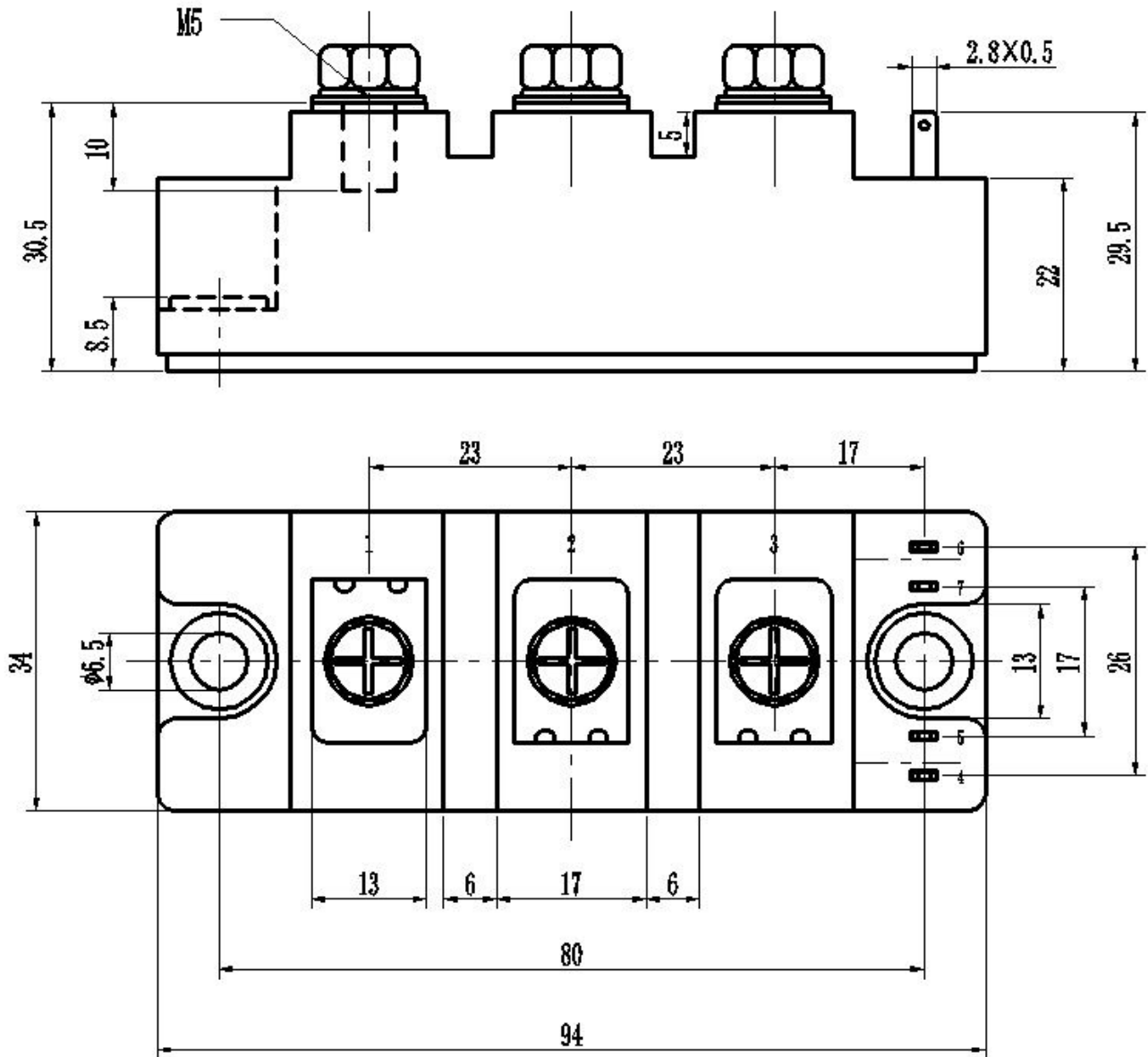

Dimensions in mm