



# MIC5512/14

Single 300mA LDO  
in 1.6mm x 1.6mm Thin DFN Package

## General Description

The MIC5512/14 is an advanced general-purpose LDO ideal for powering general-purpose portable devices. The MIC5512/14 family of products provides a high-performance 300mA LDO in an ultra-small 1.6mm x 1.6mm Thin DFN package. The MIC5512 and MIC5514 LDOs include an auto-discharge feature on the output that is activated when the enable pin is low. The MIC5514 have an internal pull down resistor on the enable pin that will disable the output when the enable pin is left floating, this is ideal for applications where the control signal is floating during processor boot up.

Ideal for battery-powered applications, the MIC5512/14 offers a typical 1% initial accuracy, low dropout voltage (160mV at 300mA), and low ground current (typically 38µA). The MIC5512/14 can also be put into a zero-off-mode current state, drawing virtually no current when disabled.

The MIC5512/14 has an operating junction temperature range of -40°C to 125°C.

Datasheets and support documentation are available on Micrel's web site at: [www.micrel.com](http://www.micrel.com).

## Features

- Input voltage range: 2.5V to 5.5V
- Fixed output voltage range: 1.0V to 3.3V
- 300mA guaranteed output current
- ±1% initial output accuracy
- Stable with 1µF ceramic output capacitors
- Low dropout voltage: 160mV @ 300mA
- Output discharge circuit
- Internal enable pull down resistor (MIC5514)
- Available in ultra-small 6-pin 1.6mm x 1.6mm Thin DFN package

## Applications

- Smart phones
- DSCs, GPS, PMPs, and PDAs
- Medical devices
- Portable electronics
- 5V systems

## Typical Application

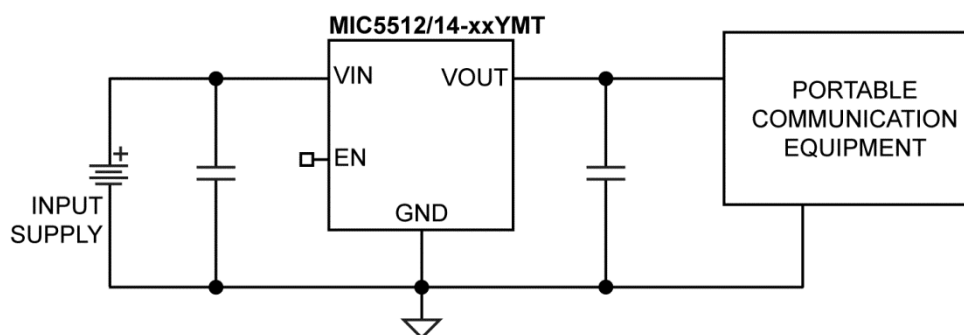

## Ordering Information

Part Number	Marking Code	Output Voltage <sup>(1)</sup>	Auto-Discharge	EN Pull-down	Temperature Range	Package <sup>(2,3)</sup>
MIC5512-1.2YMT	7E	1.2V	YES	NO	-40°C to +125°C	6-Pin 1.6mm x 1.6mm Thin DFN
MIC5512-1.8YMT	7D	1.8V	YES	NO	-40°C to +125°C	6-Pin 1.6mm x 1.6mm Thin DFN
MIC5512-2.8YMT	7C	2.8V	YES	NO	-40°C to +125°C	6-Pin 1.6mm x 1.6mm Thin DFN
MIC5512-3.3YMT	7A	3.3V	YES	NO	-40°C to +125°C	6-Pin 1.6mm x 1.6mm Thin DFN
MIC5514-1.2YMT	B8	1.2V	YES	YES	-40°C to +125°C	6-Pin 1.6mm x 1.6mm Thin DFN
MIC5514-1.8YMT	B7	1.8V	YES	YES	-40°C to +125°C	6-Pin 1.6mm x 1.6mm Thin DFN
MIC5514-2.8YMT	A9	2.8V	YES	YES	-40°C to +125°C	6-Pin 1.6mm x 1.6mm Thin DFN
MIC5514-3.0YMT	A8	3.0V	YES	YES	-40°C to +125°C	6-Pin 1.6mm x 1.6mm Thin DFN
MIC5514-3.3YMT	A7	3.3V	YES	YES	-40°C to +125°C	6-Pin 1.6mm x 1.6mm Thin DFN

### Notes:

- Other voltages are available. Contact Micrel for details.
- Thin DFN ▲ = Pin 1 identifier.
- Thin DFN is a GREEN RoHS-compliant package. Lead finish is NiPdAu. Mold compound is Halogen Free.

## Pin Configuration

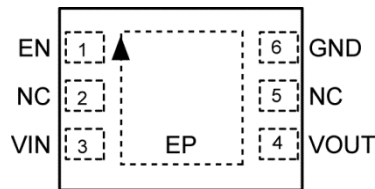

6-Pin 1.6mm x 1.6mm Thin DFN (MT)  
(Top View)

## Pin Description

Pin Number	Pin Name	Pin Function
1	EN	Enable Input: Active High. High = ON; Low = OFF. MIC5512 do not leave floating. MIC5514 has an internal 4MΩ pull down resistor and will disable VOUT when EN is floating.
2, 5	NC	Not Connected.
3	VIN	Input Supply.
4	VOUT	Output Voltage. When disabled the MIC5512/14 switches in an internal 25Ω load to discharge the external capacitors.
6	GND	Ground.
EP	ePad	Exposed Heatsink Pad. Connect to GND for best performance.

**Absolute Maximum Ratings<sup>(1)</sup>**

Supply Voltage ( $V_{IN}$ )	–0.3V to 6V
Enable Voltage ( $V_{EN}$ )	–0.3V to $V_{IN}$
Power Dissipation ( $P_D$ )	Internally Limited <sup>(3)</sup>
Lead Temperature (soldering, 10s)	260°C
Junction Temperature ( $T_J$ )	–40°C to +150°C
Storage Temperature ( $T_S$ )	–65°C to +150°C
ESD Rating <sup>(4)</sup>	3kV

**Operating Ratings<sup>(2)</sup>**

Supply Voltage ( $V_{IN}$ )	2.5V to 5.5V
Enable Voltage ( $V_{EN}$ )	0V to $V_{IN}$
Junction Temperature ( $T_J$ )	–40°C to +125°C
Junction Thermal Resistance 1.6mm × 1.6mm Thin DFN-6 ( $\theta_{JA}$ )	92.4°C/W

**Electrical Characteristics<sup>(5)</sup>**

$V_{IN} = V_{EN} = V_{OUT} + 1V$ ;  $C_{IN} = C_{OUT} = 1\mu F$ ;  $I_{OUT} = 100\mu A$ ;  $T_J = 25^\circ C$ , **bold** values indicate –40°C to +125°C, unless noted.

Parameter	Condition	Min.	Typ.	Max.	Units
Output Voltage Accuracy	Variation from nominal $V_{OUT}$	–2.0	±1	+2.0	%
	Variation from nominal $V_{OUT}$ ; –40°C to +125°C	<b>–3.0</b>		<b>+3.0</b>	
Line Regulation	$V_{IN} = V_{OUT} + 1V$ to 5.5V; $I_{OUT} = 100\mu A$		0.02	<b>0.3</b>	%/V
Load Regulation <sup>(6)</sup>	$I_{OUT} = 100\mu A$ to 300mA		8	40	mV
Dropout Voltage <sup>(7)</sup>	$I_{OUT} = 150mA$		80	<b>190</b>	mV
	$I_{OUT} = 300mA$		160	<b>380</b>	
Ground Pin Current <sup>(8)</sup>	$I_{OUT} = 0mA$		38	<b>55</b>	$\mu A$
	$I_{OUT} = 300mA$		42	<b>65</b>	
Ground Pin Current in Shutdown	$V_{EN} = 0V$		0.05	1	$\mu A$
Ripple Rejection	$f = 1kHz$ ; $C_{OUT} = 1\mu F$		65		dB
Current Limit	$V_{OUT} = 0V$	400	630	900	mA
Output Voltage Noise	$C_{OUT} = 1\mu F$ , 10Hz to 100kHz		175		$\mu V_{RMS}$
Auto-Discharge NFET Resistance	$V_{EN} = 0V$ ; $V_{IN} = 3.6V$ ; $I_{OUT} = -3mA$		25		$\Omega$
<b>Enable Input</b>					
Enable Pull-Down Resistor	MIC5514 Only		4		M $\Omega$
Enable Input Voltage	Logic Low			<b>0.2</b>	V
	Logic High	<b>1.2</b>			
Enable Input Current MIC5512	$V_{EN} = 0V$		0.01	1	$\mu A$
	$V_{EN} = 5.5V$		0.01	1	
Enable Input Current MIC5514	$V_{EN} = 0V$		0.01	1	$\mu A$
	$V_{EN} = 5.5V$		1.4	2	
Turn-On Time	$C_{OUT} = 1\mu F$ ; $I_{OUT} = 150mA$		50	<b>125</b>	$\mu s$

**Notes:**

- Exceeding the absolute maximum rating may damage the device.
- The device is not guaranteed to function outside its operating rating.
- The maximum allowable power dissipation of any  $T_A$  (ambient temperature) is  $P_{D(max)} = (T_{J(max)} - T_A) / \theta_{JA}$ . Exceeding the maximum allowable power dissipation will result in excessive die temperature, and the regulator will go into thermal shutdown.
- Devices are ESD sensitive. Handling precautions are recommended. Human body model, 1.5k $\Omega$  in series with 100pF.
- Specification for packaged product only.
- Regulation is measured at constant junction temperature using low duty cycle pulse testing. Changes in output voltage due to heating effects are covered by the thermal regulation specification.
- Dropout voltage is defined as the input-to-output differential at which the output voltage drops 2% below its nominal value measured at 1V differential. For outputs below 2.5V, dropout voltage is the input-to-output differential with the minimum input voltage 2.5V.
- Ground pin current is the regulator quiescent current. The total current drawn from the supply is the sum of the load current plus the ground pin current.

# Typical Characteristics

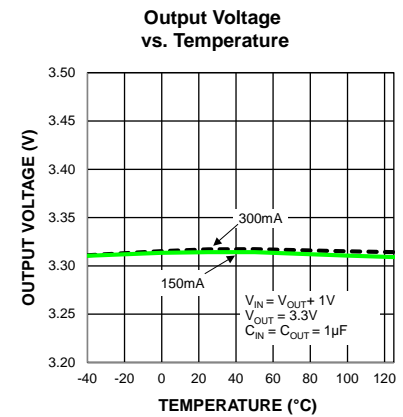
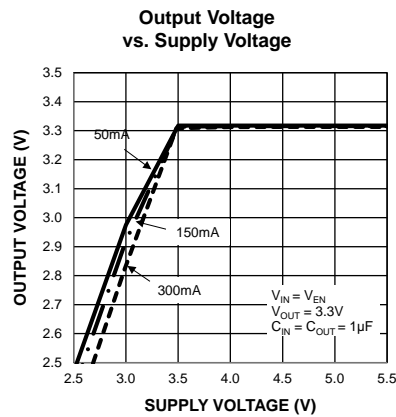
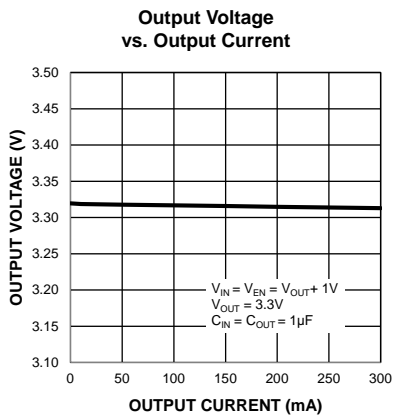
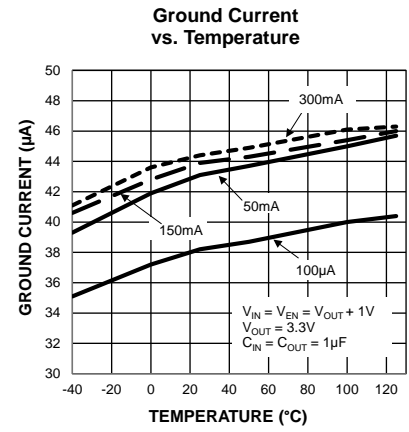
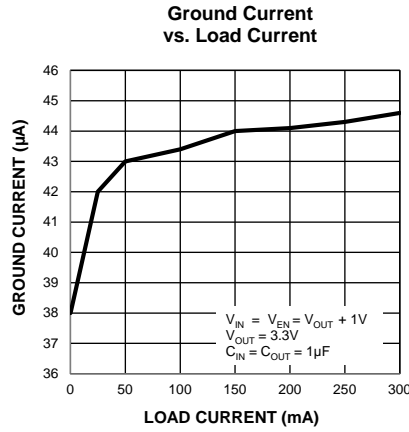
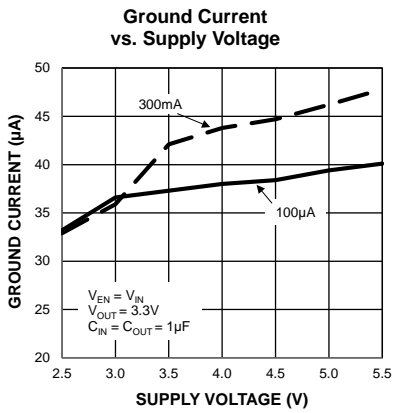
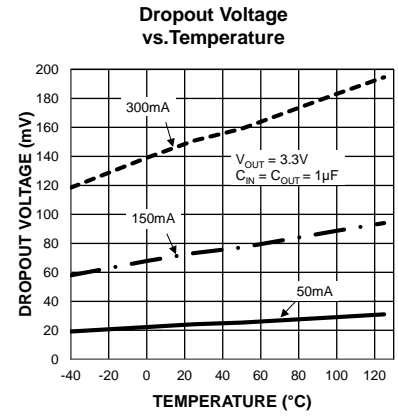
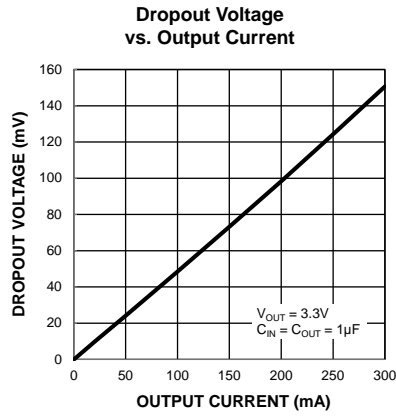
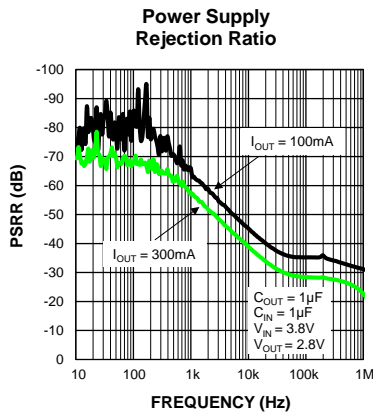

### Typical Characteristics (Continued)

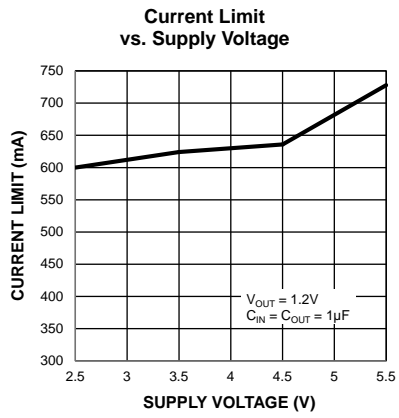

## Functional Characteristics

Enable Turn-On

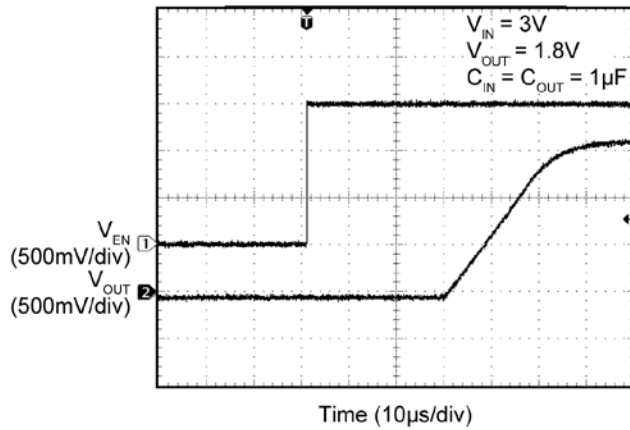

Enable Turn-On

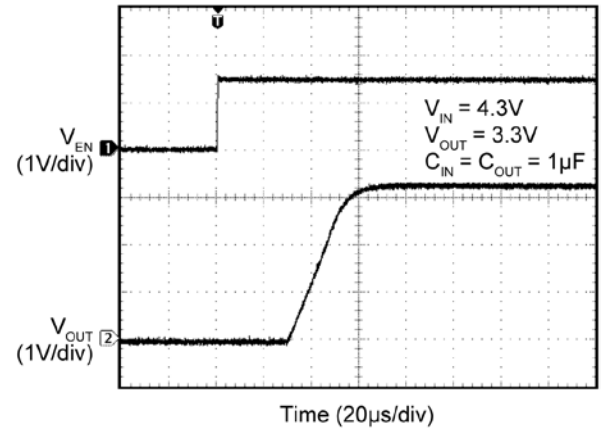

Load Transient

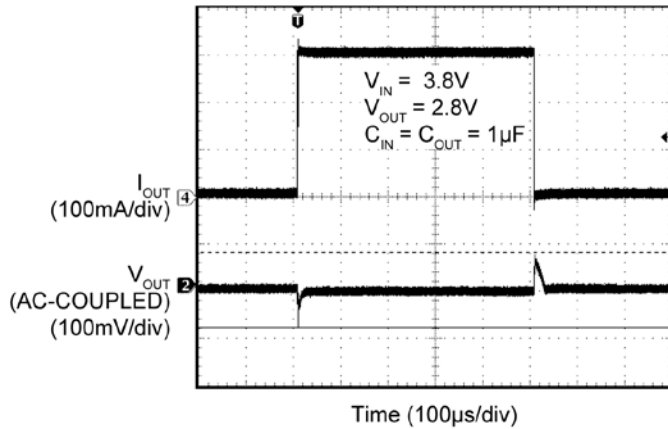

Load Transient

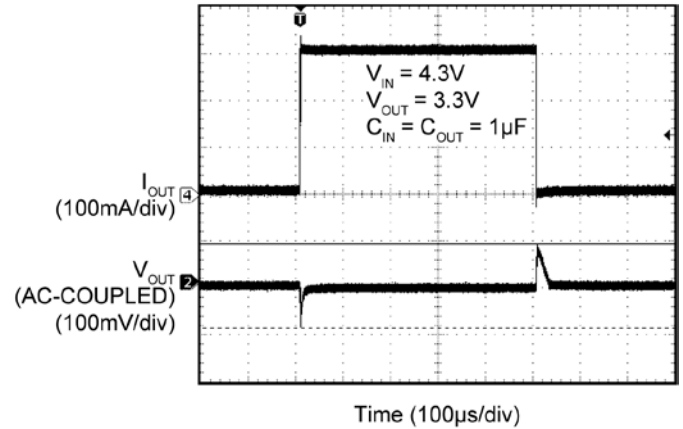

Line Transient

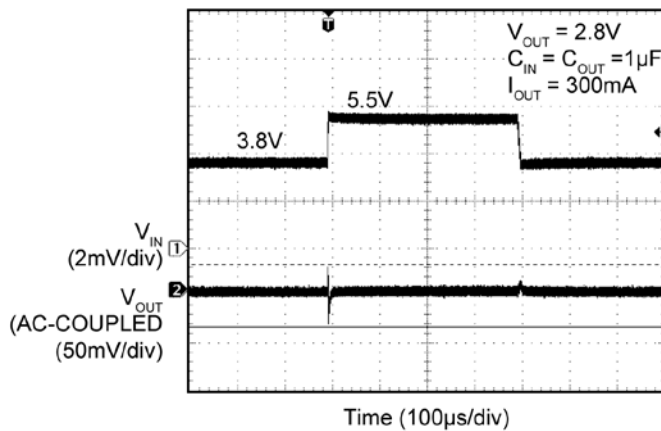

Auto Discharge (No Load)

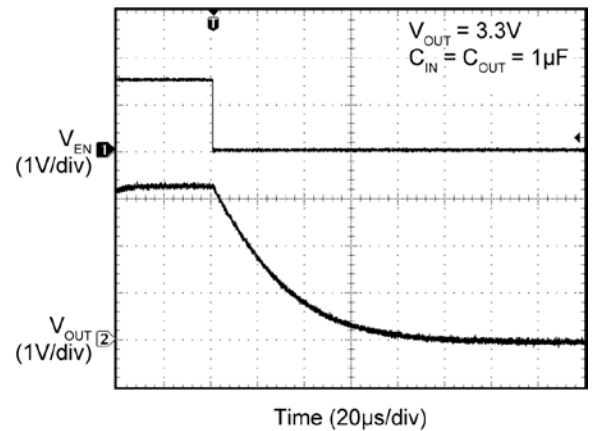

### Block Diagram

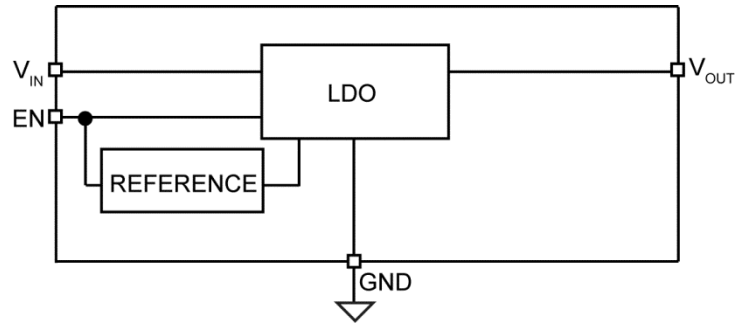

MIC55xx Block Diagram

## Application Information

MIC5512/14 are high performance 300mA LDOs. The MIC5512/14 includes an auto-discharge circuit that is switched on when the regulator is disabled through the enable pin. The MIC5512/14 regulators are fully protected from damage due to fault conditions, offering linear current limiting and thermal shutdown.

### Input Capacitor

The MIC5512/14 is a high-performance, high-bandwidth device. An input capacitor of 1 $\mu$ F is required from the input to ground to provide stability. Low-ESR ceramic capacitors provide optimal performance at a minimum of space. Additional high-frequency capacitors, such as small-valued NPO dielectric-type capacitors, help filter out high-frequency noise and are good practice in any RF-based circuit. X5R or X7R dielectrics are recommended for the input capacitor. Y5V dielectrics lose most of their capacitance over temperature and are therefore, not recommended.

### Output Capacitor

The MIC5512/14 requires an output capacitor of 1 $\mu$ F or greater to maintain stability. The design is optimized for use with low-ESR ceramic chip capacitors. High-ESR capacitors are not recommended because they may cause high-frequency oscillation. The output capacitor can be increased, but performance has been optimized for a 1 $\mu$ F ceramic output capacitor and does not improve significantly with larger capacitance.

X7R/X5R dielectric-type ceramic capacitors are recommended because of their temperature performance. X7R-type capacitors change capacitance by 15% over their operating temperature range and are the most stable type of ceramic capacitors. Z5U and Y5V dielectric capacitors change value by as much as 50% and 60%, respectively, over their operating temperature ranges. To use a ceramic chip capacitor with Y5V dielectric, the value must be much higher than an X7R ceramic capacitor to ensure the same minimum capacitance over the equivalent operating temperature range.

### No-Load Stability

Unlike many other voltage regulators, the MIC5512/14 remains stable and in regulation with no load. This is especially important in CMOS RAM keep-alive applications.

### Enable/Shutdown

The MIC5512/14 comes with an active-high enable pin that allows the regulator to be disabled. Forcing the enable pin low disables the regulator and sends it into an off mode current state drawing virtually zero current. When disabled the MIC5512/14 switches an internal 25 $\Omega$  load on the regulator output to discharge the external capacitor.

Forcing the enable pin high enables the output voltage. The MIC5512 enable pin uses CMOS technology and the enable pin cannot be left floating; a floating enable pin may cause an indeterminate state on the output. The MIC5514 has an internal pull down resistor on the enable pin to disable the output when the enable pin is floating.

### Thermal Considerations

The MIC5512/14 is designed to provide 300mA of continuous current in a very small package. Maximum ambient operating temperature can be calculated based on the output current and the voltage drop across the part. For example if the input voltage is 3.6V, the output voltage is 2.8V, and the output current = 300mA. The actual power dissipation of the regulator circuit can be determined using Equation 1:

$$P_D = (V_{IN} - V_{OUT1}) I_{OUT} + V_{IN} I_{GND} \quad \text{Eq. 1}$$

Because this device is CMOS and the ground current is typically <100 $\mu$ A over the load range, the power dissipation contributed by the ground current is < 1% and can be ignored for Equation 2:

$$P_D = (3.6V - 2.8V) \times 300mA$$

$$P_D = 0.240W \quad \text{Eq. 2}$$

To determine the maximum ambient operating temperature of the package, use the junction-to-ambient thermal resistance of the device and Equation 3:

$$P_{D(MAX)} = \left( \frac{T_{J(MAX)} - T_A}{\theta_{JA}} \right) \quad \text{Eq. 3}$$

$T_{J(MAX)} = 125^\circ\text{C}$ , the maximum junction temperature of the die,  $\theta_{JA}$  thermal resistance = 92.4 $^\circ\text{C/W}$  for the DFN package.

Substituting  $P_D$  for  $P_{D(MAX)}$  and solving for the ambient operating temperature will give the maximum operating conditions for the regulator circuit. The junction-to-ambient thermal resistance for the minimum footprint is 92.4 $^\circ\text{C/W}$ .

The maximum power dissipation must not be exceeded for proper operation.

For example, when operating the MIC5512-MYMT at an input voltage of 3.6V and 300mA load with a minimum footprint layout, the maximum ambient operating temperature  $T_A$  can be determined as in Equation 4:

$$0.240W = (125^{\circ}\text{C} - T_A)/(92.4^{\circ}\text{C}/\text{W})$$
$$T_A = 102.8^{\circ}\text{C} \qquad \text{Eq. 4}$$

Therefore, the maximum ambient operating temperature allowed in a 1.6mm x 1.6mm DFN package is 102.8°C. For a full discussion of heat sinking and thermal effects on voltage regulators, refer to the “Regulator Thermals” section of *Micrel’s Designing with Low-Dropout Voltage Regulators* handbook. This information can be found on Micrel’s website at:  
[http://www.micrel.com/\\_PDF/other/LDOBk\\_ds.pdf](http://www.micrel.com/_PDF/other/LDOBk_ds.pdf)

### Typical Application Schematic

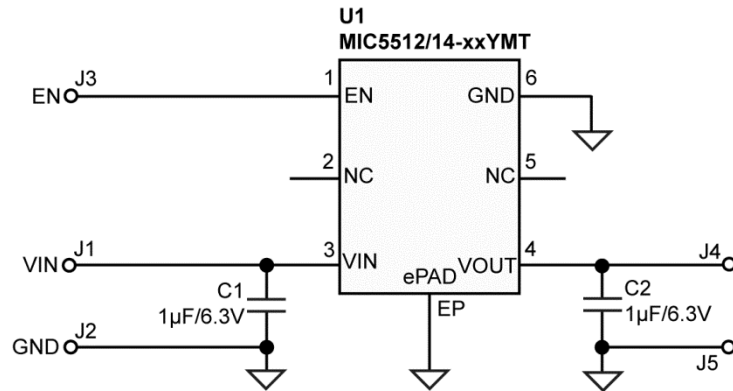

### Bill of Materials

Item	Part Number	Manufacturer	Description	Qty.
C1, C2	GRM155R61A105KE15D	Murata <sup>(1)</sup>	1µF Ceramic Capacitor, 10V, X5R, Size 0402	2
U1	MIC5512-xxYMT	Micrel, Inc. <sup>(2)</sup>	Single 300mA LDO in 1.6mm × 1.6mm Thin DFN Package	1
	MIC5514-xxYMT			

**Notes:**

1. Murata: [www.murata.com](http://www.murata.com).
2. Micrel, Inc.: [www.micrel.com](http://www.micrel.com).

### PCB Layout Recommendations

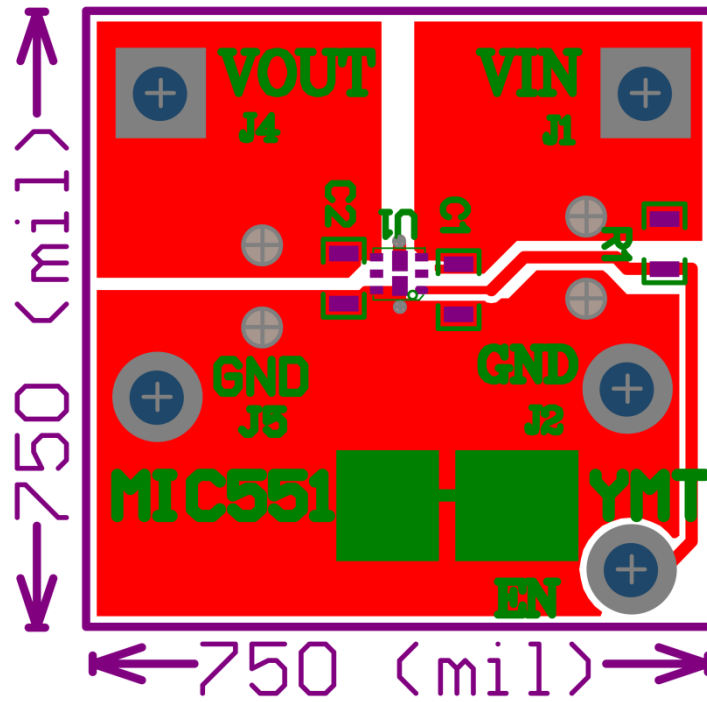

Top Layer

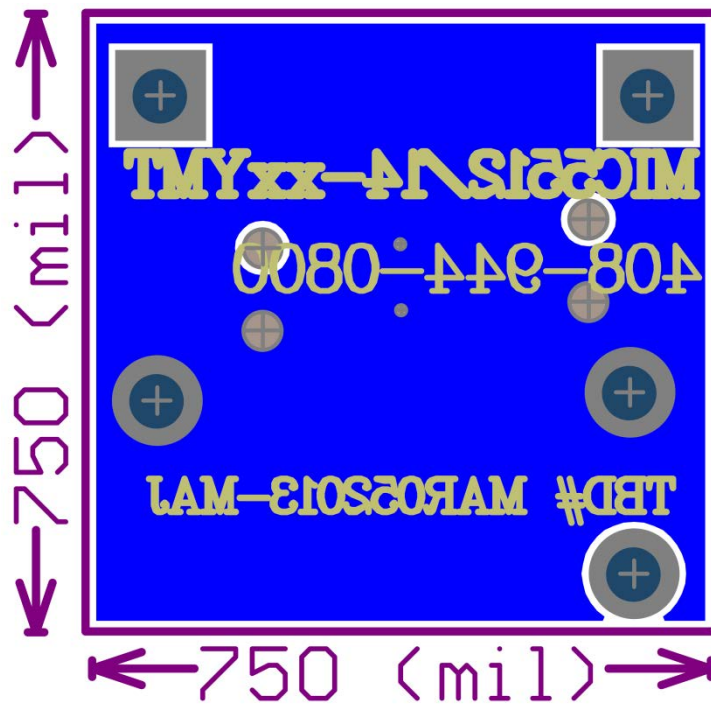

Bottom Layer

# Package Information<sup>(1)</sup> and Recommended Landing Pattern

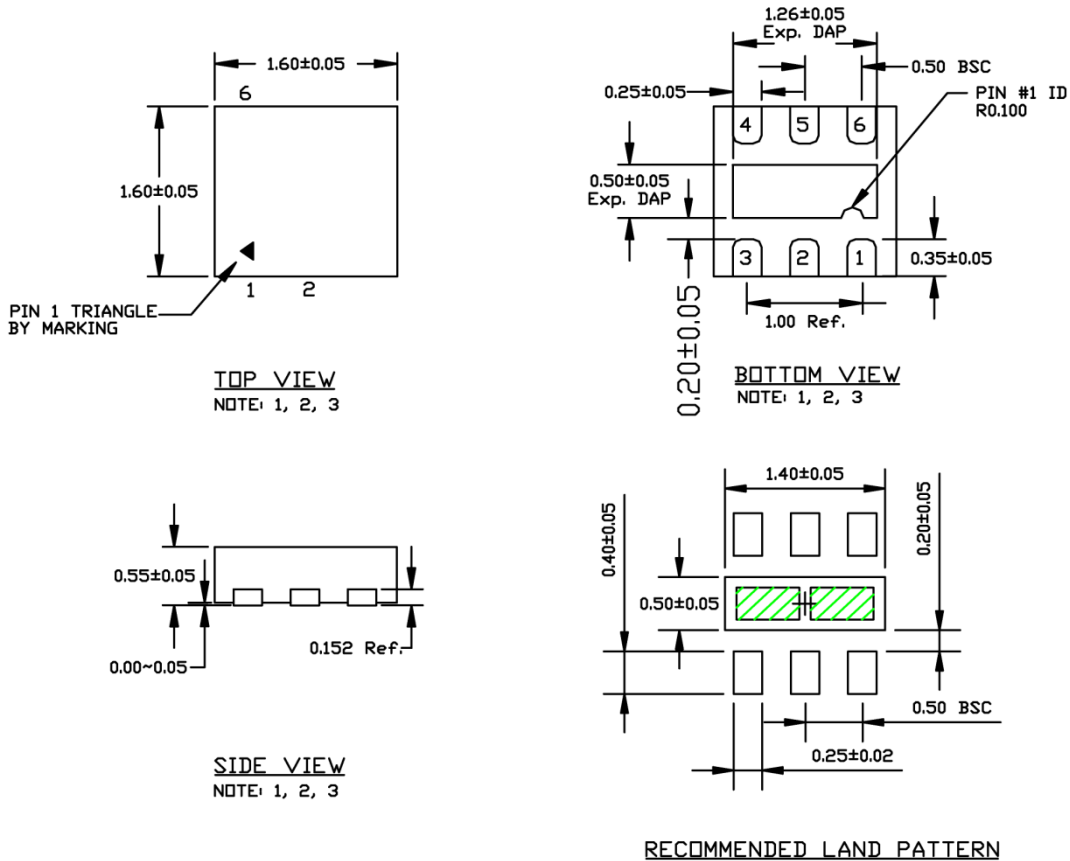

- NOTE:**
1. MAX PACKAGE WARPAGE IS 0.05 MM
  2. MAX ALLOWABLE BURR IS 0.076MM IN ALL DIRECTIONS
  3. PIN #1 IS ON TOP WILL BE LASER MARKED
  4. GREEN SHADED AREA REPRESENT SOLDER STENCIL OPENING (OPTIONAL) FOR IMPROVED THERMAL PERFORMANCE. SIZE: 0.55x0.30MM

## 6-Pin 1.6mm x 1.6mm Thin DFN (MT)

**Note:**

1. Package information is correct as of the publication date. For updates and most current information, go to [www.micrel.com](http://www.micrel.com).

**MICREL, INC. 2180 FORTUNE DRIVE SAN JOSE, CA 95131 USA**  
 TEL +1 (408) 944-0800 FAX +1 (408) 474-1000 WEB <http://www.micrel.com>

Micrel makes no representations or warranties with respect to the accuracy or completeness of the information furnished in this data sheet. This information is not intended as a warranty and Micrel does not assume responsibility for its use. Micrel reserves the right to change circuitry, specifications and descriptions at any time without notice. No license, whether express, implied, arising by estoppel or otherwise, to any intellectual property rights is granted by this document. Except as provided in Micrel's terms and conditions of sale for such products, Micrel assumes no liability whatsoever, and Micrel disclaims any express or implied warranty relating to the sale and/or use of Micrel products including liability or warranties relating to fitness for a particular purpose, merchantability, or infringement of any patent, copyright or other intellectual property right.

Micrel Products are not designed or authorized for use as components in life support appliances, devices or systems where malfunction of a product can reasonably be expected to result in personal injury. Life support devices or systems are devices or systems that (a) are intended for surgical implant into the body or (b) support or sustain life, and whose failure to perform can be reasonably expected to result in a significant injury to the user. A Purchaser's use or sale of Micrel Products for use in life support appliances, devices or systems is a Purchaser's own risk and Purchaser agrees to fully indemnify Micrel for any damages resulting from such use or sale.