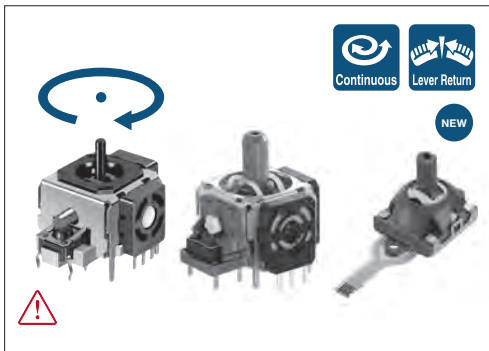

RKJXK
RKJXV
RKJX2
ThumbPointer™ (Stick Controller)

Compact size, standard type. Also available with lever return mechanism

Typical Specifications (Potentiometer)

Items	RKJXK	RKJXV	RKJX2
Rated power	0.0125W		
Maximum operating voltage	50V AC, 5V DC		5V DC
Operating angle	60° ±6°	23° max. in each direction*	23° max. in each direction
Operating force	8mN·m max. (Not lever return type) 6±4mN·m (Lever return type)	14±10mN·m	7 ⁺⁵ ₋₃ mN·m
Operating life	100,000 cycles	2,000,000 cycles	

Note

* If the lever is tilted more than 23° from the vertical position, operating feel irregularities or return mechanism errors may occur. Therefore, please do not tilt more than 23°.

Typical Specifications (Center-push)

Items	RKJXK	RKJXV	RKJX2
Ratings (max.)	50mA 12V DC		5V DC 1mA
Operating force	5.2±2.6N	7.4±3N	6.0±2.5N
Travel	0.5 ^{+0.5} _{-0.4} mm	0.4 ^{+0.5} _{-0.3} mm	0.35 ^{+0.5} _{-0.25} mm
Operating life	100,000 cycles	500,000 cycles	

Product Line

Product No.	Lever return mechanism	Center-push	Total resistance (kΩ)	Resistance taper	Minimum order unit (pcs.)		Drawing No.
					Japan	Export	
RKJXK122400Y	With	With	10	B(OB)	500	1,000	1
RKJXK122000D		Without					2
RKJXK1210002	Without						
RKJXV122400R	With	With			1,420	1,420	3
RKJXV1220001		Without					4
RKJX21224001		With			5	1,484	1,484

Packing Specifications

Tray





Product No.	Number of packages (pcs.)		Export package measurements (mm)
	1 case / Japan	1 case / export packing	
RKJXK	500	1,000	540×373×225
RKJXV	1,420	1,420	544×364×178
RKJX2	1,484	1,484	

*Products marked with a are not recommended for new designs

*Products marked with a  are not recommended for new designs

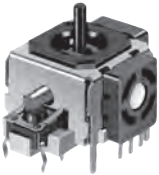
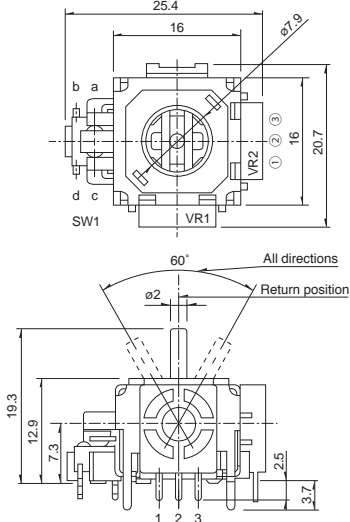
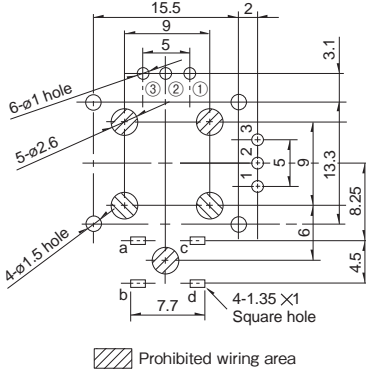
Dimensions

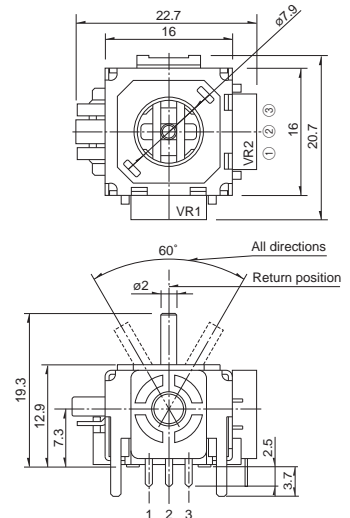
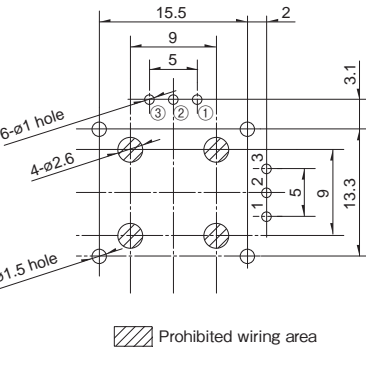
Unit:mm

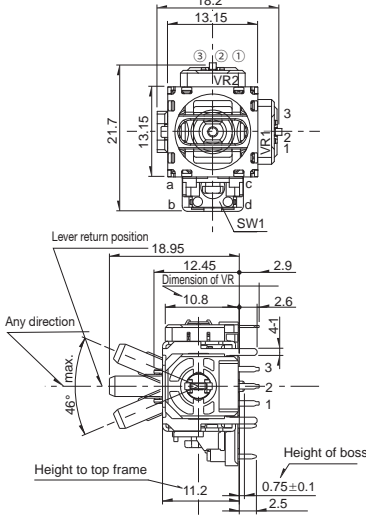
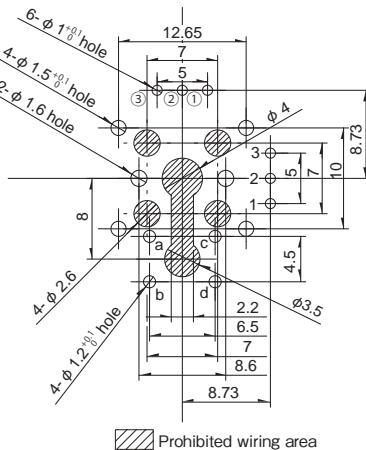
No.	Photo	Style	PC board mounting hole dimensions (Viewed from mounting side)
<p></p> <p>1</p>	<p>RKJXK1224</p> 		
<p></p> <p>2</p>	<p>RKJXK1210 RKJXK1220</p> 		
<p>3</p>	<p>RKJXV1224</p> 		



Multi Control
Devices

Variable
Resistor Type

Switch Type

■ Dimensions

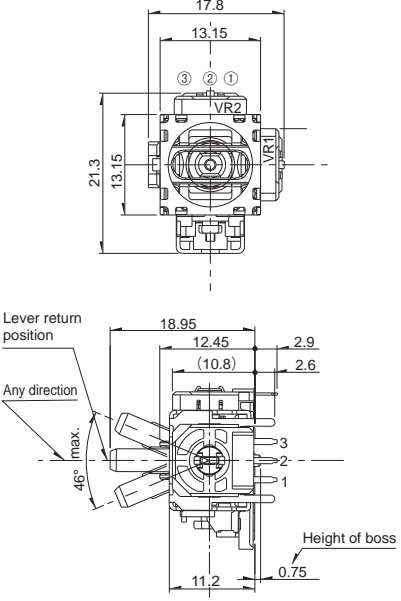
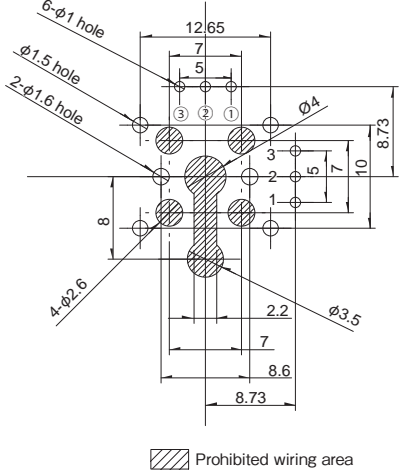
Unit:mm

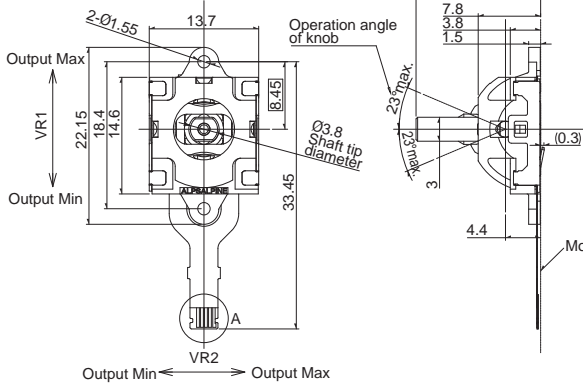
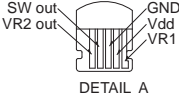
No.	Photo	Style	PC board mounting hole dimensions (Viewed from mounting side)
4			 <p>Prohibited wiring area</p>
5			

Multi Control
Devices







Variable
Resistor Type

Switch Type

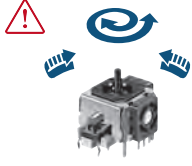
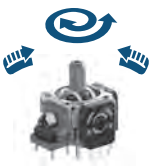
Multi Control Devices

List of Varieties

*Products marked with a  are not recommended for new designs

Type		Potentiometer type			
Series		RKJXK	RKJXV	RKJX2	RKJXU
Photo					
Dimensions (typical value) (mm)	W	20.7	17.8	13.7	18.6
	D	25.4	21.3	14.6	24.3
	H	12.9	11.2	7.8	5.2
Shaft material		Metal		Resin	
Directional resolution		Continuous			
Directional operating feeling (tactile feeling)		Without			
Lever return mechanism		With / Without		With	
Center-push switch		With / Without		With	Without
Encoder		Without			
Operating temperature range		-10°C to +70°C		-10°C to +50°C	-10°C to +70°C
Operating life	Directional operation	100,000 cycles	2,000,000 cycles	2,000,000 cycles	2,000,000 cycles
	Center-push	100,000 cycles	500,000 cycles	500,000 cycles	—
Automotive use		—			
Life cycle (availability)					
Electrical performance	Insulation resistance	100MΩ min. 250V DC			—
	Voltage proof	250V AC for 1 minute			—
	Slider noise	300mV p-p max. by JIS method		300mV p-p max.	300mV p-p max. by JIS method
Mechanical performance	Directional operating force	8mN·m max. Without Lever return mechanism 6±4mN·m With Lever return mechanism	14±10mN·m	7 ⁺⁵ ₋₃ mN·m	0.75±0.3N
	Push operating force	5.2±2.6N	7.4±3N	6±2.5N	—
	Lever return precision	±5°			±0.1mm
	Actuator strength	Push / pull directions	50N min. (Push/Pull)	98N min. (Push), 50N min. (Pull)	
Operating direction		0.3N·m	—		50N
Environmental performance	Cold	-30°C 96h			
	Dry heat	80°C 96h			
	Damp heat	60°C, 90 to 95%RH 96h			
Page		393			396

Variable Resistor Type Multi Control Devices Soldering Conditions 397
 Variable Resistor Type Multi Control Devices Cautions 397

Potentiometer Type Multi Control Devices / Soldering Conditions

Reference for Manual Soldering

Series	Tip temperature	Soldering time	No. of solders
RKJXK, RKJXV	350°Cmax.	3s max.	1 time

Reference for Dip Soldering

Series	Preheating		Dip soldering		No. of solders
	Soldering surface temperature	Heating time	Soldering temperature	Soldering time	
RKJXK	90 to 100°C	45s max.	255 to 260°C	2 to 3s	1 time
RKJXV	90 to 120°C	60s max.	260°C	5s	1 time

Potentiometer Type Multi Control Devices / Cautions

[Circuit Used for Analog Stick Controller]

We recommend you use the potentiometer type in a voltage divider type as shown in Fig. A.

[Impedance on the Output Side]

Since this pot is designed to use with its output is connected directly to A/D port. Impedance is considered to be mega ohm level. Then contact resistance in the pot is higher. Please refer to [Fig. 1]. So when you use it in the circuit like [Fig. 2]. Please make sure that impedance should be over than 1M-ohm.

[Dew Condensation]

Avoid using the product when condensation or drops of water might occur inside the product. Otherwise, insulation deterioration or shorting may occur.

[Soldering]

Do not employ wiring designs and soldering methods as illustrated in the schematic drawing. Molten solder flowing over the upper surface of PC board can cause imperfect contacts. Solder all metal inserted fixing including terminals & metal lugs into a substrate.

[Stress Being Applied to the Terminals]

Always be careful not to apply excessive stress on the terminals. Design appropriate soldering conditions.

[Handling of Variable Resistors Equipped with Switches]

Exercise care when packing or storing. Packaging or storing while load is applied to the shaft may cause a malfunction in performance.

[Storage]

- ① Store the products as delivered, at a normal temperature and humidity, without direct sunshine and corrosive gas ambient. Use them at an earliest possible timing, not later than six months upon receipt.
- ② After breaking the seal, keep the products in a plastic bag to shut out ambient air, store them in the same environment as above, and use them up as soon as possible.
- ③ Do not stack too many switches.

The above operation notes are quoted from the

"Precaution and Guideline of Potentiometer for Electrical Devices", a technical report issued by the Japan Electronics and Information Technology Industries Association EIAJ RCR-2191A (in March 2002).

For details, refer to the original technical report.

Fig.A.Voltage divider type

