



RS1001FL~RS1010FL

SMALL SURFACE MOUNT FAST DIODES

VOLTAGE 100 to 1000 Volt **CURRENT** 1 Ampere

FEATURES

- For surface mounted applications in order to optimize board space
- Ideal for automated placement
- Glass Passivated Chip Junction
- High temperature soldering : 260°C / 10 seconds at terminals
- Ultra thin profile package for space constrained utilization
- Lead free in compliance with EU RoHS 2.0
- Green molding compound as per IEC 61249 standard

MECHANICAL DATA

- Case : JEDEC SOD-123FL, Molded plastic over passivated junction
- Terminals : Solderable per MIL-STD-750, Method 2026
- Standard Packaging : 8mm tape (EIA-481)
- Apporx. Weight : 0.0006 ounces, 0.0173 grams
- Polarity : Color band cathode



SOD-123FL Unit : inch(mm)

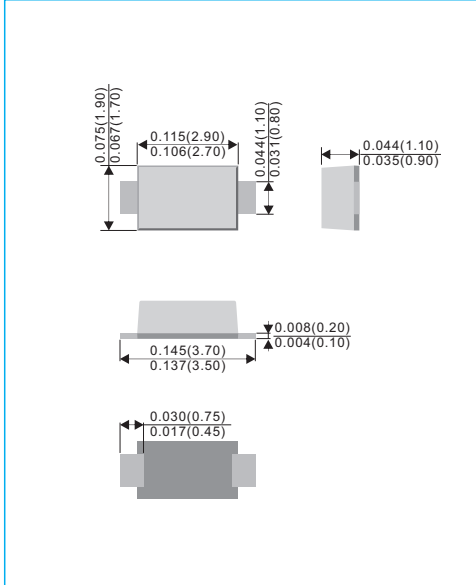

MAXIMUM RATINGS AND ELECTRICAL CHARACTERISTICS

Ratings at 25°C ambient temperature unless otherwise specified. Single phase, half wave, 60Hz, resistive or inductive load.
For capacitive load, derate current by 20%

Rating	Test condition	Symbol	RS1001FL	RS1002FL	RS1004FL	RS1006FL	RS1008FL	RS1010FL	Units
Marking code		-	R1B	R1D	R1G	R1J	R1K	R1M	-
Maximum repetitive peak reverse voltage		V_{RRM}	100	200	400	600	800	1000	V
Maximum rms voltage		V_{RMS}	70	140	280	420	560	700	V
Maximum dc blocking voltage		V_{DC}	100	200	400	600	800	1000	V
Maximum average forward rectified current Derate above $T_c=110^\circ\text{C}$		$I_{F(AV)}$	1						A
Maximum instantaneous forward voltage	0.7A 1A	V_F	1.15 1.3						V
Peak forward surge current : 8.3ms single half sine-wave superimposed on rated load		I_{FSM}	30						A
Maximum dc reverse current at rated dc blocking voltage	$T_J=25^\circ\text{C}$ $T_J=125^\circ\text{C}$	I_R	1 50						μA
Typical capacitance	4V,1MHz	C_J	9						pF
Reverse recovery time	$I_F=0.5\text{A}$ $I_R=-1\text{A}$ $I_{rr}=-0.25\text{A}$	t_{rr}	150			250		500	nS
Typical thermal resistance junction to ambient (Note1)		$R_{\theta JA}$	200						$^\circ\text{C/W}$
Operating junction and storage temperature range		T_J, T_{STG}	-55 to +150						$^\circ\text{C}$

Note: 1. Mounted on a FR4 PCB, single-sided copper, mini pad.



RS1001FL~RS1010FL

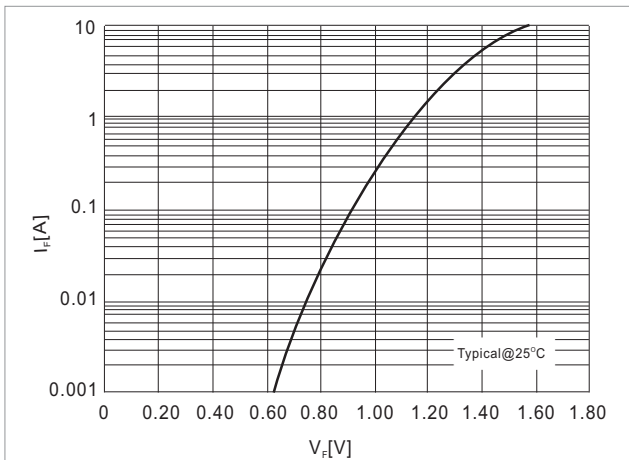

Fig.1-TYPICAL FORWARD CHARACTERISTICS

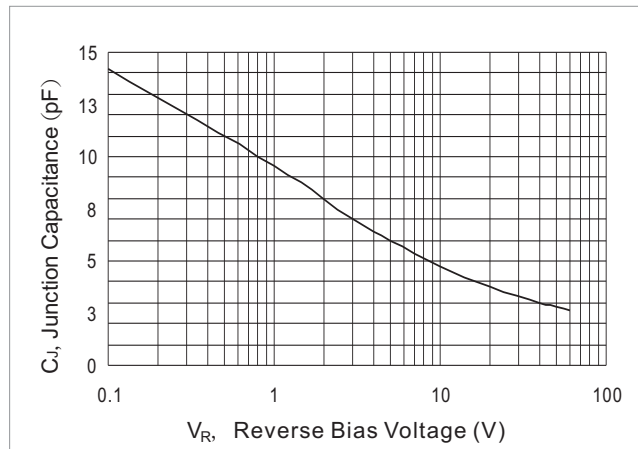

Fig.2-TYPICAL JUNCTION CAPACITANCE

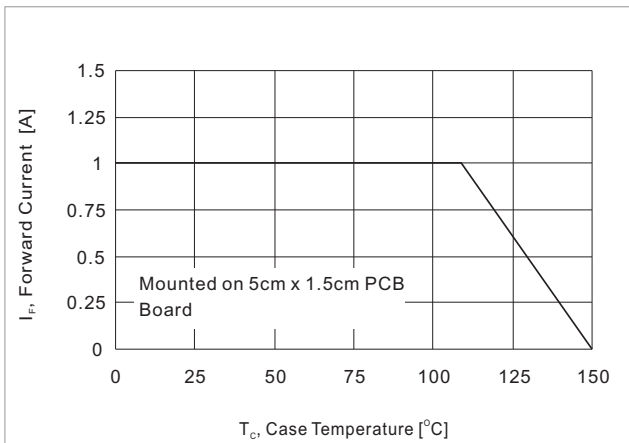

Fig.3-FORWARD CURRENT DERATING CURVE

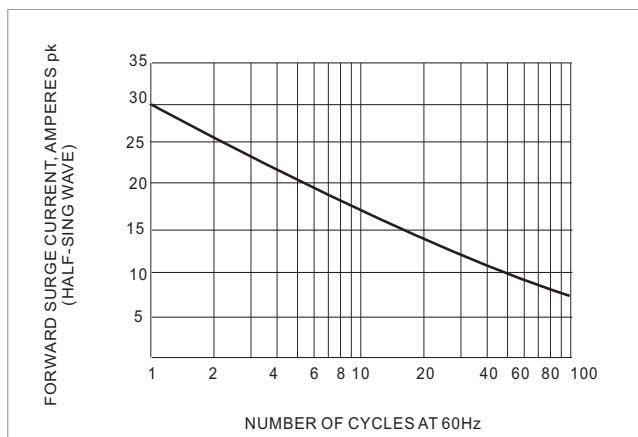
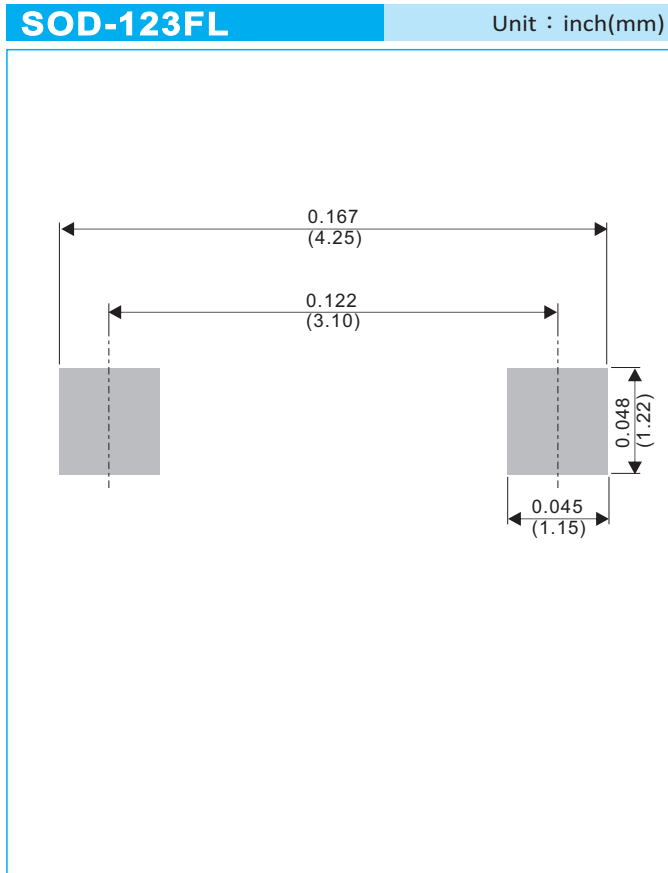

Fig.4-MAXIMUM NON-REPEITIVE SURGE CURRENT



RS1001FL~RS1010FL

MOUNTING PAD LAYOUT



ORDER INFORMATION

- Packing information
T/R - 10K per 13" plastic Reel
T/R - 3K per 7" plastic Reel



RS1001FL~RS1010FL

Part No_packing code_Version

RS1001FL_R1_00001

RS1001FL_R2_00001

For example :

RB500V-40_R2_00001

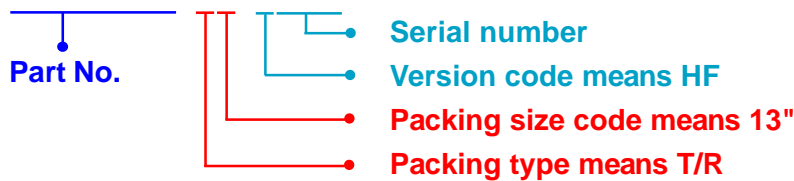

Packing Code XX				Version Code XXXXX		
Packing type	1 st Code	Packing size code	2 nd Code	HF or RoHS	1 st Code	2 nd ~5 th Code
Tape and Ammunition Box (T/B)	A	N/A	0	HF	0	serial number
Tape and Reel (T/R)	R	7"	1	RoHS	1	serial number
Bulk Packing (B/P)	B	13"	2			
Tube Packing (T/P)	T	26mm	X			
Tape and Reel (Right Oriented) (TRR)	S	52mm	Y			
Tape and Reel (Left Oriented) (TRL)	L	PANASERT T/B CATHODE UP (PBCU)	U			
FORMING	F	PANASERT T/B CATHODE DOWN (PBCD)	D			



RS1001FL~RS1010FL

Disclaimer

- Reproducing and modifying information of the document is prohibited without permission from Panjit International Inc..
- Panjit International Inc. reserves the rights to make changes of the content herein the document anytime without notification. Please refer to our website for the latest document.
- Panjit International Inc. disclaims any and all liability arising out of the application or use of any product including damages incidentally and consequentially occurred.
- Panjit International Inc. does not assume any and all implied warranties, including warranties of fitness for particular purpose, non-infringement and merchantability.
- Applications shown on the herein document are examples of standard use and operation. Customers are responsible in comprehending the suitable use in particular applications. Panjit International Inc. makes no representation or warranty that such applications will be suitable for the specified use without further testing or modification.
- The products shown herein are not designed and authorized for equipments requiring high level of reliability or relating to human life and for any applications concerning life-saving or life-sustaining, such as medical instruments, transportation equipment, aerospace machinery et cetera. Customers using or selling these products for use in such applications do so at their own risk and agree to fully indemnify Panjit International Inc. for any damages resulting from such improper use or sale.
- Since Panjit uses lot number as the tracking base, please provide the lot number for tracking when complaining.