

# Low-profile Master Type (Slim Type) RS\*\*N11S Series

- [Photo](#) | 
 [Dimensions](#) | 
 [Mounting Hole Dimensions](#) | 
 [Terminal Layout / Circuit Diagram](#) | 
 [Packing Specifications](#) | 
 [Soldering Conditions](#) |

PRINT

Part number	<b>RSA0N11S9A0K</b>	
Number of resistor elements	Single-unit	
Direction of lever	Vertical	
Travel	100mm	
Lever type	9-T (T-Bar)	
Length of lever	8.2mm	
Total resistance	10kΩ	
Resistance taper	1B	
Terminal style	For PC board	
Operating temperature range	-10°C to +60°C	
Electrical performance	Total resistance tolerance	±20%
	Maximum operating voltage	500V AC, 10V DC
	Rated power	0.5W
	Insulation resistance	100MΩ min. 250V DC
	Voltage proof	250V AC for 1 minute
Mechanical performance	Operating force	0.3(+0.5, -0.25)N
	Stopper strength	100N
	Lever push-pull strength	50N
	Lever wobble (Both side)	1.312mm
	Lever deviation (One side)	0.5mm max.
Durability	Operating life	30,000 cycles
Minimum order unit (pcs.)	Japan	400
	Export	800



## Photo



## Dimensions

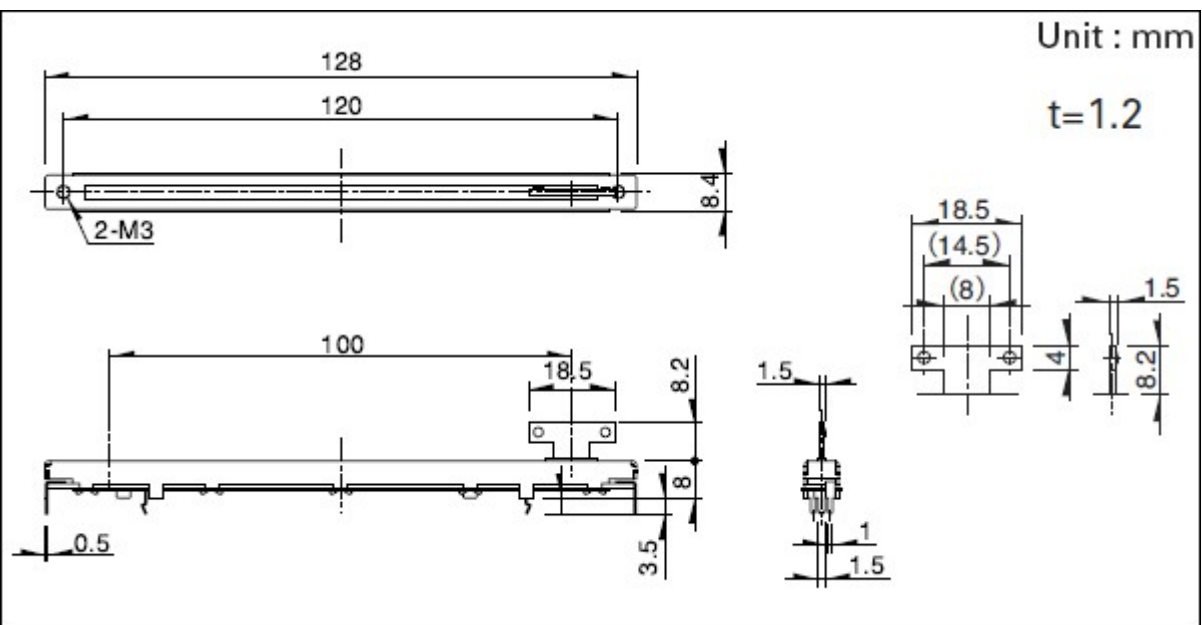

## Mounting Hole Dimensions

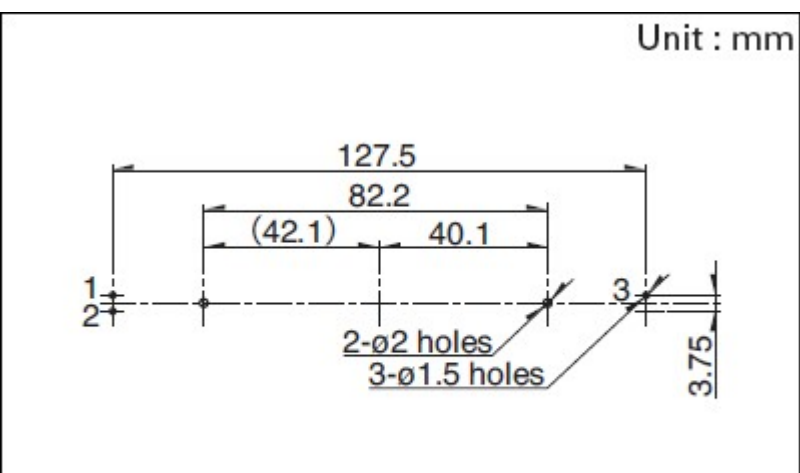

Viewed from mounting side.

## Terminal Layout / Circuit Diagram

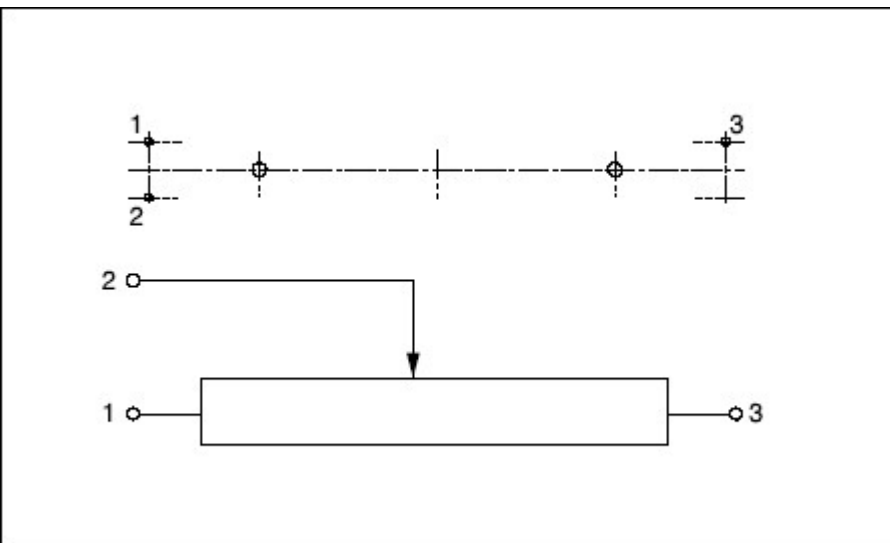

## Packing Specifications

### Tray

Number of packages (pcs.)	1 case / Japan	400
	1 case / export packing	800

Export package measurements (mm)	377×517×371
----------------------------------	-------------

## Soldering Conditions

### Reference for Dip Soldering

Preheating	Soldering surface temperature	100° max.
	Heating time	1 min. max.
Dip soldering	Soldering temperature	260° max.
	Soldering time	5s max.
No. of solders		1 time

### Reference for Hand Soldering

Tip temperature	350° max.
Soldering time	3s max.
No. of solders	1 time

Notes are common to this series/models.

1. This site catalog shows only outline specifications. When using the products, please obtain formal

specifications for supply.

2. Please place purchase orders per minimum order unit (integer).
3. Products other than those listed in above products are also available. Please contact us for details.
4. "L" in the "Lever Wobble" column of the above table indicates the length of lever.

## Inquiries about Products

 [Inquiry](#)