

SP-3S

To fit 3.2mm hole
chassis 1.6mm

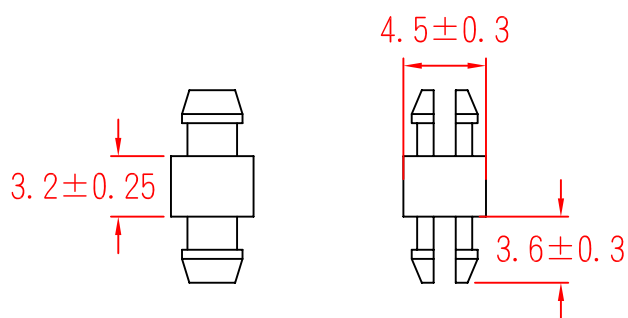

To fit 3.2mm hole
chassis 1.6mm

承認
KSS
97.07.22
邱平裕

審查

製圖
KSS
97.07.22
謝文通

設計

中文名
PC板隔離柱

MATERIAL UL 94V-2
NYLON 66

ITEM NO.
SP-3S

SCALE

FINISH

NAME

MINATURE SUPPORT POST

使用機種

△ (. .)

TOLERANCE
AS FIGURE

△ (. .)
07-22-2008
DATE

REVISIONS K001

R.NO.



凱士士企業股份有限公司

▶ 請勿實測圖面 ◀