

# TLE4929C Crankshaft Sensor

## Fully Programmable Crankshaft Sensor



### Applications

The TLE4929C is an active Hall sensor ideally suited for crankshaft applications and similar industrial applications, such as speedometer or any speed-sensor with high accuracy and low jitter capabilities.

### Features

- Measures speed and position of tooth/pole wheels
- Switching point in middle of the tooth enables backward compatibility
- Magnetic stray-field robustness due to differential sensing principle
- Digital output signal with programmable output-protocol including diagnosis interface
- Direction detection and Stop-Start-Algorithm
- High accuracy and low jitter
- High sensitivity enable large air gap
- End-of-line programmable to adapt to engine parameters
- Can be used as a differential Camshaft sensor
- Wide automotive operating temperature range

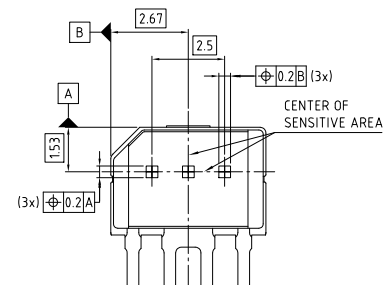
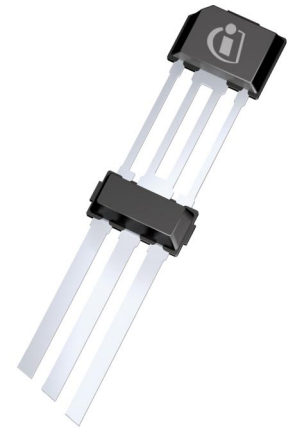

**Figure 1 Typical Application Circuit**

### Description

The TLE4929C comes in a RoHS compliant three-pin package, qualified for automotive usage. It has two integrated capacitors on the lead frame (Figure 1). These capacitors increase the EMC resistivity of the device. A pull-up resistor  $R_{Load}$  is mandatory on the output pin and determines the maximum current through the output transistor.

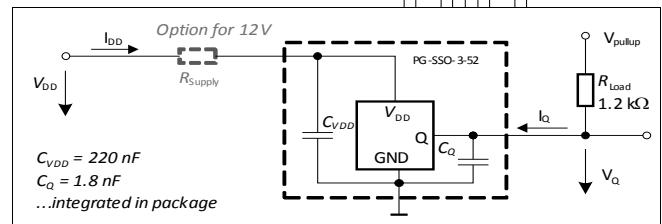

**Table 1 Version**

Type	Description	Marking	Ordering Code	Package
TLE4929C-XAN-M28	EEPROM preprogrammed and locked	29AIC0	SP001670330	PG-SSO-3-52
TLE4929C-XAF-M28	EEPROM unlocked	29AIC1	SP001671646	PG-SSO-3-52

## Table of Contents

	<b>Applications</b> .....	<b>1</b>
	<b>Features</b> .....	<b>1</b>
	<b>Description</b> .....	<b>1</b>
	<b>Table of Contents</b> .....	<b>2</b>
<b>1</b>	<b>General Characteristics</b> .....	<b>3</b>
1.1	Absolute Maximum Ratings .....	3
1.2	Operating Range .....	4
<b>2</b>	<b>Electrical and Magnetic Characteristics</b> .....	<b>7</b>
<b>3</b>	<b>Functional Description</b> .....	<b>11</b>
3.1	Definition of the Magnetic Field Direction .....	11
3.2	Block Diagram .....	11
3.3	Basic Operation .....	11
3.3.1	Power-on Phase .....	14
3.3.2	Initial Phase .....	14
3.3.3	Calibration Phase .....	14
3.3.4	Running Phase .....	14
3.3.5	Averaging Algorithm .....	15
3.3.6	Direction Detection .....	15
3.3.7	Direction Detection Threshold .....	16
3.4	Hysteresis Concept .....	17
3.5	Rotational Direction Definition and Edge Polarity Definition .....	18
3.6	System Watchdog .....	20
3.7	Stop Start Watchdog .....	20
3.8	High Speed Mode .....	21
3.9	Serial Interface .....	21
<b>4</b>	<b>EEPROM Description</b> .....	<b>22</b>
<b>5</b>	<b>Package Information</b> .....	<b>24</b>
5.1	Package Outline .....	25
5.2	Marking and Data Matrix Code .....	26
5.3	Packing Information .....	26
<b>6</b>	<b>Revision History</b> .....	<b>27</b>

## 1 General Characteristics

### 1.1 Absolute Maximum Ratings

**Table 2 Absolute Maximum Ratings**

Parameter	Symbol	Values			Unit	Note or Test Condition
		Min.	Typ.	Max.		
<b>Voltages</b>						
Supply voltage without supply resistor	$V_{DD}$	-16	–	18	V	continuous, $T_J \leq 175^\circ\text{C}$
		–	–	27	V	max. 60s, $T_J \leq 175^\circ\text{C}$
		-18	–	–	V	max. 60s, $T_J \leq 175^\circ\text{C}$
Output OFF voltage	$V_{Q\_OFF}$	-1.0	–	–	V	max. 1h, $T_{Amb} \leq 40^\circ\text{C}$
		-0.3	–	26.5	V	continuous, $T_J \leq 175^\circ\text{C}$
Output ON voltage	$V_{Q\_ON}$	–	–	16	V	continuous, $T_{Amb} \leq 40^\circ\text{C}$
		–	–	18	V	max. 1 h, $T_{Amb} \leq 40^\circ\text{C}$
		–	–	26.5	V	max. 60 s, $T_{Amb} \leq 40^\circ\text{C}$
<b>Temperatures</b>						
Junction temperature range	$T_J$	-40	–	185	$^\circ\text{C}$	Exposure time: max. $10 \times 1 \text{ h}$ , $V_{DD} = 16\text{V}$
<b>Induction</b>						
Magnetic field induction	$B_z^{1)}$	-5	–	5	T	Magnetic pulse during magnet magnetization. Valid 10 s with $T_{ambient} \leq 80^\circ\text{C}$
<b>ESD Resistivity</b>						
ESD compliance	$ESD_{HBM}$	-6	–	6	kV	HBM <sup>2)</sup>

1) Guaranteed by design

2) ESD susceptibility, HBM according to EIA/JESD 22-A114B

**Note:** Stresses above the max values listed here may cause permanent damage to the device. Exposure to absolute maximum rating conditions for extended periods may affect device reliability. Maximum ratings are absolute ratings; exceeding only one of these values may cause irreversible damage to the integrated circuit.

## 1.2 Operating Range

All parameters specified in the following sections refer to these operating conditions unless otherwise specified.

**Table 3 General Operating Conditions**

Parameter	Symbol	Values			Unit	Note or Test Condition
		Min.	Typ.	Max.		
<b>Voltages</b>						
Supply voltage without supply resistance $R_s$	$V_{DD}$	4.0	-	16	V	
Continuous Output Off voltage	$V_{Q\_OFF}$	-	-	16	V	
Supply voltage power- up/down voltage ramp	$dV_{DD}/dt$	3.0	-	1e4	V/ms	
<b>Currents</b>						
Supply current	$I_{DD}$	8.0	-	13.4	mA	
Continuous output On current	$I_{Q\_ON}$		-	15	mA	$V_{Q\_LOW} < 0.5 V$
<b>Capacitance</b>						
Capacitance between IC supply & ground pins	$C_{VDD}$	198	220	242	nF	
Output capacitance between IC output and ground pins	$C_Q$	1.62	1.8	1.98	nF	
<b>Direction Detection</b>						
Frequency range for direction detection	$f_{Dir}$	0	-	1800	Hz	For increasing rotational frequency
		0	-	1500	Hz	For decreasing rotational frequency
<b>Programming</b>						
Maximum No. of EEPROM programming cycles	$N_{PROG}$	-	-	100	n	
<b>Magnetic Signal</b>						
Magnetic signal frequency range	$f$	0	-	8000	Hz	Full accuracy
		8000	-	10000	Hz	10% degraded jitter
Dynamic range of the magnetic field of the differential speed channel	$DR_{mag\_field\_s}$	-120	-	120	mT	ADC-range
Dynamic range of the magnetic field of the direction channel	$DR_{mag\_field\_dir}$	-60	-	60	mT	ADC-range
Static range of the magnetic field of the outer Hall probes in back-bias configuration	$SR_{mag\_field\_s\_bb}$	0	-	550	mT	No wheel in front of module / Offset-DAC-Compensation-range

**Table 3 General Operating Conditions (Continued)**

Parameter	Symbol	Values			Unit	Note or Test Condition
		Min.	Typ.	Max.		
Static range of the magnetic field of the outer Hall probes in magnetic encoder wheel configuration	$SR_{mag\_field\_s\_pw}$	-10	-	10	mT	Static absolute offset for pole wheel / Offset-DAC-Compensation-range / independent from Bit "POLE_WHEEL"
Static range of the magnetic field of the center Hall probe	$SR_{mag\_field\_dir}$	-100	-	450	mT	No wheel in front of module / Center-Offset-DAC-Compensation-range
Allowed static difference between outer probes	$SR_{mag\_field\_diff}$	-30	-	30	mT	No wheel in front of module
Magnetic differential field amplitude for full performance on stop-start	$\Delta B_{Speed\_Stop,Start}$	9	-	-	mTpk pk	No false pulses for temperature drift of $\leq 60$ K during stop-start state. Tolerated change of speed-channel mean value $\leq 3$ mT
		6	-	-	mTpk pk	No false pulses for temperature drift of $\leq 40$ K during stop-start state. Tolerated change of speed-channel mean value $\leq 2$ mT
		4	-	-	mTpk pk	No false pulses for temperature drift of $\leq 20$ K during stop-start state. Tolerated change of speed-channel mean value $\leq 1.5$ mT

**Temperatures**

Normal operating junction temperature	$T_J$	-40	-	175	°C	Exposure time: max. 2500 h at $T_J = 175^\circ\text{C}$ , $V_{DD} = 16$ V
		-	-	185	°C	Exposure time: max. $10 \times 1$ h at $T_J = 185^\circ\text{C}$ , $V_{DD} = 16$ V, additive to other lifetime
Not operational lifetime	$T_{no}$	-40		150	°C	Without sensor function. Exposure time max 500 h @ $150^\circ\text{C}$ ; increased time for lower temperatures according to Arrhenius-Model, additive to other lifetime

**Table 3 General Operating Conditions (Continued)**

Parameter	Symbol	Values			Unit	Note or Test Condition
		Min.	Typ.	Max.		
Ambient temperature range for customer programming	$T_{RDPROG}$	15	25	130	°C	
Temperature variations between engine stop and restart.	$\Delta T_{Stop,start}$	–	–	60	°C	Device powered continuously
Temperature compensation range of magnetic material	TC	-1400	–	0	ppm	Internal compensation of magnetic signal amplitude of speed signal

## 2 Electrical and Magnetic Characteristics

All values specified at constant amplitude and offset of input signal, over operating range, unless otherwise specified. Typical values correspond to  $V_S = 5\text{ V}$  and  $T_{\text{Amb.}} = 25^\circ\text{C}$

**Table 4 Electrical and Magnetic Parameters**

Parameter	Symbol	Values			Unit	Note or Test Condition
		Min.	Typ.	Max.		
<b>Voltage</b>						
Output saturation voltage	$V_{Q\text{sat}}$	-	-	500	mV	$I_Q \leq 15\text{ mA}$
Clamping voltage $V_{DD}$ -Pin	$V_{DD\_clamp}$	42	-	-	V	leakage current through ESD-diode $< 0.5\text{ mA}$
Clamping voltage $V_Q$ -Pin	$V_{Qclamp}$	42	-	-	V	leakage current through ESD-diode $< 0.5\text{ mA}$
Reset voltage	$V_{DD\_reset}$	-	-	3.6	V	
<b>Current</b>						
Output leakage current	$I_{Qleak}$	-	0.1	10	$\mu\text{A}$	$V_Q = 18\text{ V}$
Output current limit during short-circuit condition	$I_{Qshort}$	30	-	80	mA	
<b>Temperature</b>						
Junction temperature limit for output protection	$T_{prot}$	190	-	205	$^\circ\text{C}$	
<b>Time and Frequency</b>						
Power on time	$t_{power\_on}$	0.8	0.9	1	ms	During this time the output is locked to high.
Delay time between magnetic signal switching point and corresponding output signal falling edge switching event	$t_{delay}$	10	14	19	$\mu\text{s}$	Falling edge
Output fall time	$t_{fall}$	2.0	2.5	3.0	$\mu\text{s}$	$V_{Pullup} = 5\text{ V}$ , $R_{Pullup} = 1.2\text{ k}\Omega$ (+/-10%), $C_Q = 1.8\text{ nF}$ (+/-15%), valid between 80% - 20%
		3.2	4.5	5.8	$\mu\text{s}$	$V_{Pullup} = 5\text{ V}$ , $R_{Pullup} = 1.2\text{ k}\Omega$ (+/-10%), $C_Q = 1.8\text{ nF}$ (+/-15%), valid between 90% - 10%
Output rise time	$t_{rise}^{1)}$	4	-	11.4	$\mu\text{s}$	$R_{Pullup} = 1.2\text{ k}\Omega$ (+/-10%), $C_Q = 1.8\text{ nF}$ (+/-15%), valid between 10% - 90%

### Minimum Field Change during Start up to generate Output Switching

**Table 4 Electrical and Magnetic Parameters (Continued)**

Parameter	Symbol	Values			Unit	Note or Test Condition
		Min.	Typ.	Max.		
Digital noise constant of speed channel during start up (change in differential field)	$DNC_{min}$	0.53	0.75	0.97	mTpkpk	EEPROM "DNC_MIN": Option 00 <sup>2)</sup>
		1.22	1.5	1.78	mTpkpk	EEPROM "DNC_MIN": Option 01
		2.14	2.5	2.86	mTpkpk	EEPROM "DNC_MIN": Option 10
		4.44	5	5.56	mTpkpk	EEPROM "DNC_MIN": Option 11

**Hysteresis Of Switching Threshold**

Minimum hysteresis threshold of speed channel	$HYS_{min}$	0.53	0.75	0.97	mTpkpk	EEPROM "HYST": Option 0 <sup>2)</sup>
		1.22	1.5	1.78	mTpkpk	EEPROM "HYST": Option 1
Adaptive hysteresis threshold of speed channel	$HYS_{adaptive}$	-	25	-	%	EEPROM "HYST_ADAPT": Option 0
		-	31.25	-	%	EEPROM "HYST_ADAPT": Option 1
Switching level offset	SwitchOff set,Error	-350	-	350	$\mu$ T	For magnetic speed signal = 10 mTpkpk : resulting in phase error / duty cycle error.

**Accuracy and Repeatability**

Repeatability (Jitter)	Jitter <sup>3)</sup>	-	-	0.015	°Crank	3 sigma, $\Delta B_{pkpk} = 20mTpkpk$
		-	-	0.025	°Crank	3 sigma, $\Delta B_{pkpk} = 9mTpkpk$ , measured on coil using sinus signal, $T_a=150^\circ C$ , $f=8kHz$
Number of wrong pulses at start-up	$nStart^{4)}$	-	-	0	n	Engine starts in continuous forward rotational direction
		0	-	1	n	Engine starts in continuous backward rotational direction
Number of wrong pulses after stop-start	$nStop, start^{4)}$	-	-	0	n	Multiple rotational direction changes > 6°Crank allowed
Maximum phase error	$Phirunning^{3)}$	-0.2	-	0.2	°Crank	$\Delta B_{Speed} > 9mTpkpk$ ,signature excluded, accuracy on mentioned wheel in <b>Figure 2</b>
Maximum phase error after stop-start	$Phistop, start^{3)}$	-1.7	-	3.2	°Crank	Reduced phase accuracy only for first pulse after stop-start-state / signature excluded

**Run Out Capabilities**

**Table 4 Electrical and Magnetic Parameters (Continued)**

Parameter	Symbol	Values			Unit	Note or Test Condition
		Min.	Typ.	Max.		
Global run out (speed and direction channel)	Runoutglobal <sup>4)</sup>	1.0	–	1.67	–	Ratio = Amplitude(max)pkpk / Amplitude(min)pkpk
		1.0	–	2.5	–	Ratio = Amplitude(max)pkpk / Amplitude(min)pkpk . Reduced performance in Stop-Start-behavior.
Magnetic overshoot of signature region in speed signal. Magnetic overshoot from tooth to tooth (polepair to polepair)	Runouttooth, tooth <sup>4)</sup>	0.8	1.2	1.6	–	Ratio = Amplitude(signature) / Amplitude(before/after). Valid for toothed target wheel.
		0.7	1.4	2.5	–	Ratio = Amplitude(signature) / Amplitude(before/after). Valid for magnetic target wheel.

**Output Protocol Variants**

Crankshaft without direction detection: Output follows profile of target wheel	–	–	–	–	–	Output “Q” changes state (“LOW” or “HIGH”) in the middle of the tooth / middle of the notch
Standard crankshaft protocol with direction	$t_{fwd}$	38	45	52	$\mu s$	VPullup = 5 V, $R_{pullup}$ = 1.2 k $\Omega$ (+/- 10%), $C_Q$ = 1.8 nF (+/-15%), valid between 50% of falling edge to 50% of next rising edge
	$t_{bwd}$	76	90	104	$\mu s$	
Optional crankshaft protocol with direction	$t_{fwd}$	38	45	52	$\mu s$	
	$t_{bwd}$	113	135	157	$\mu s$	

- 1) Application parameter, IC does not increase the rise time (max. value), Values are calculated and not tested
- 2) Smallest setting is not recommended for harsh environment: long tooth, long notch, vibration, run-out of target-wheel.
- 3) Parameter not subject to productive test. Verified by characterization in the laboratory based on jitter-measurement > 1000 falling edges.
- 4) Parameter not subject to productive test. Verified by laboratory characterization / design.

*Note: The listed Electrical and magnetic characteristics are ensured over the operating range of the integrated circuit. Typical characteristics specify mean values expected over the production spread. If not other specified, typical characteristics apply at  $T_{Amb} = 25^{\circ}C$  and  $V_S = 5 V$ .*

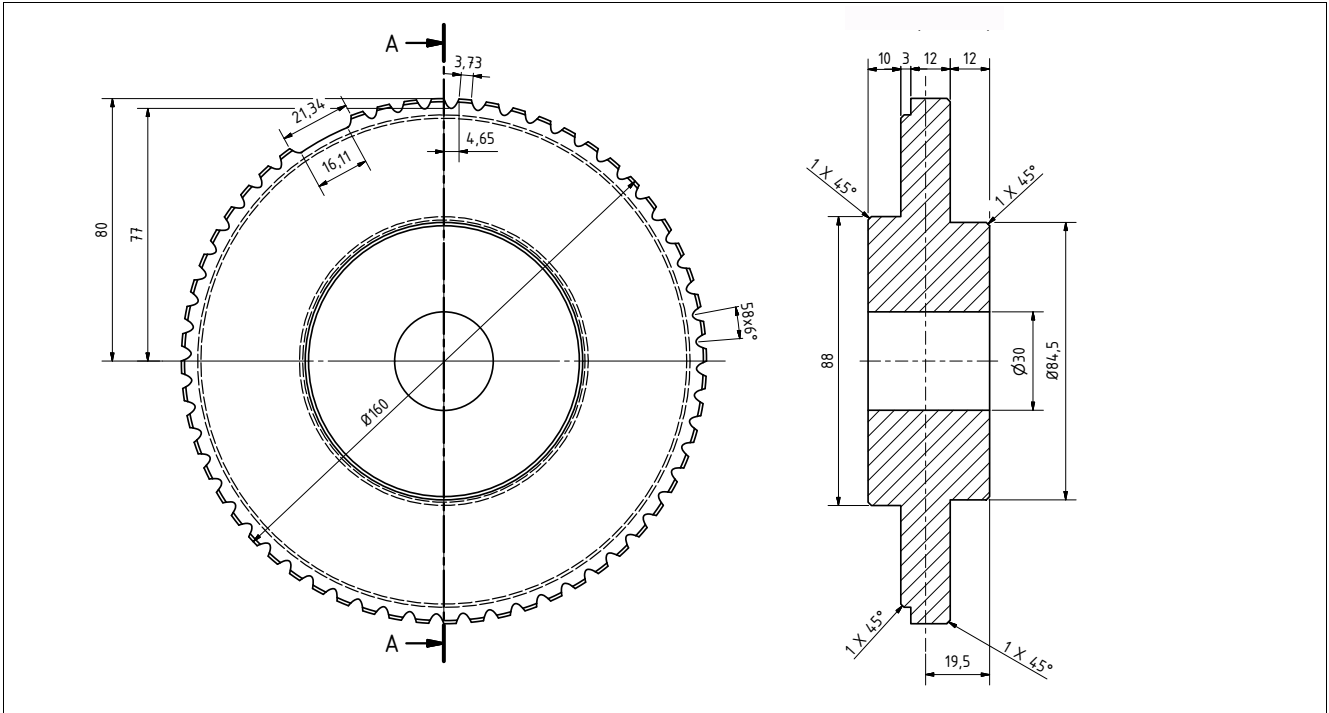

Figure 2 OEM-crankshaft wheel (outer diameter = 160mm)

### 3 Functional Description

#### 3.1 Definition of the Magnetic Field Direction

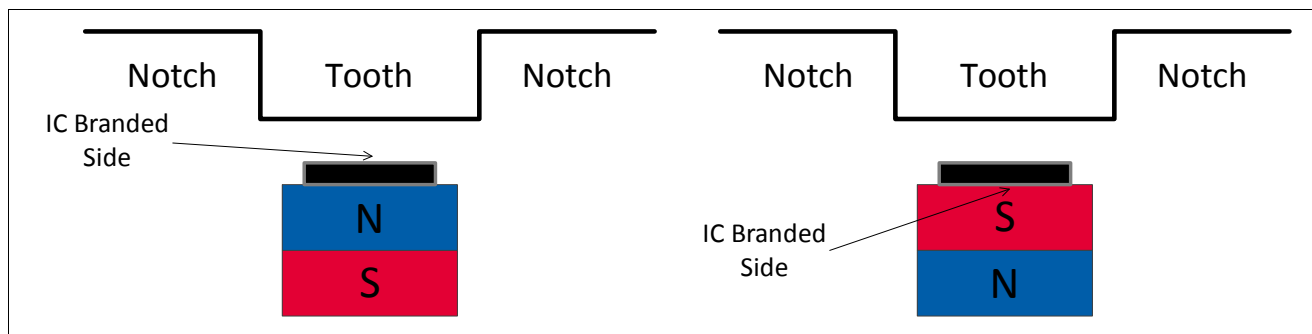

Figure 3 Definition of the Positive Magnetic Field Direction

#### 3.2 Block Diagram

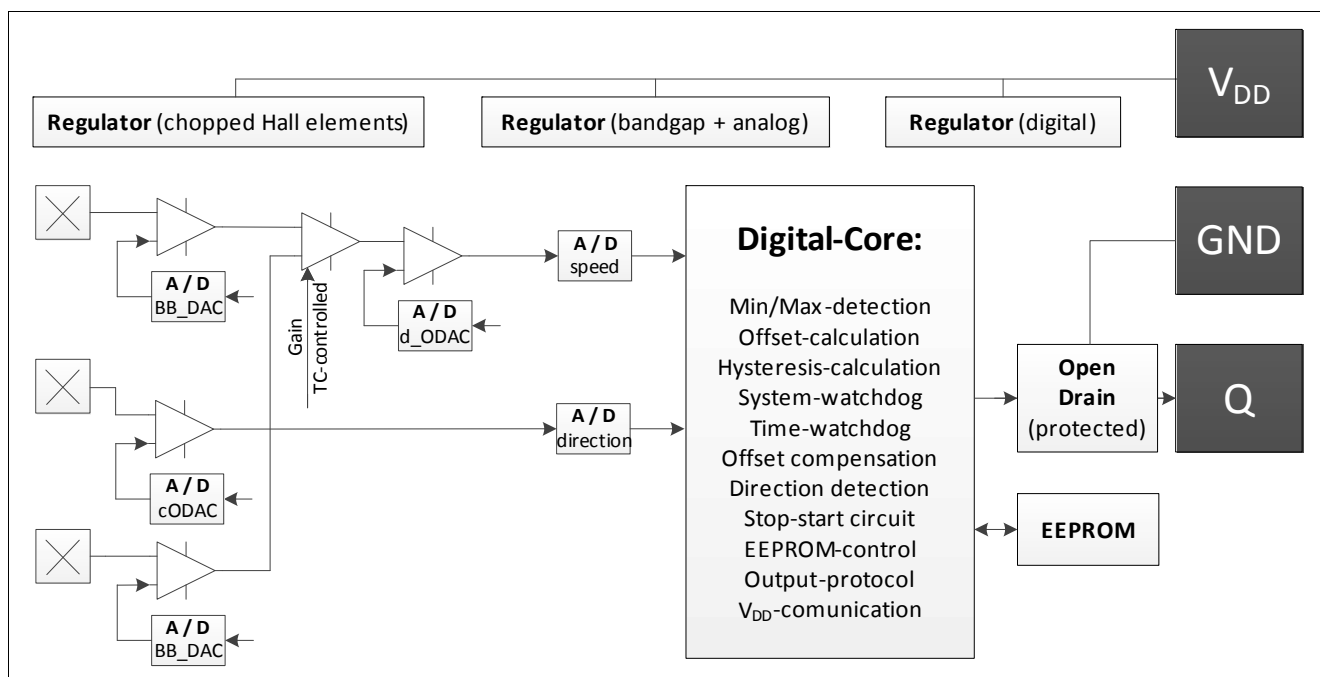

Figure 4 Block Diagram

#### 3.3 Basic Operation

The basic operation of the TLE4929C is to transpose the magnetic field produced by a spinning target wheel into speed pulses with directional information at the output pin. The pulse width indicates forward or backward direction information and can be adjusted in EEPROM-options. It is also possible to parameterize output switching without direction information like it is requested for differential CAM-shaft sensors. The correspondence between field polarity and output polarity can be set according to the application needs as well. By definition a magnetic field is considered as positive if the magnetic North Pole is placed at the rear side of the sensor, see [Figure 3](#).

For understanding the operation five different phases have to be considered:

- Power-on phase

- starts after supply release
- lasts  $t_{\text{power-on}}$  (power-on time)
- IC loads configuration and settings from EEPROM and initializes state machines and signal path
- output is locked HIGH
- Initial phase (**Figure 5** "uncalibrated mode")
  - starts after Power-on phase
  - lasts one clock cycle
  - IC enables output switching, extrema detection and threshold adaption
- Calibration phase 1 (**Figure 5** "calibrated mode")
  - starts after Initial phase
  - lasts until the sensor has observed 3 magnetic edges (maximum 4 magnetic edges) and is able to perform the most likely final threshold update needed for transition to "Calibration Phase 2".
  - IC performs fast adaptation of the threshold according to the application magnetic field
  - initial and second switching (uncalibrated mode) of the output is performed according to the detected field change of the differential magnetic field
  - length of the output-pulse is derived from the center Hall probe (direction signal) sampled at the zero-crossing of the differential outer Hall probes (speed signal)
  - length of the very first pulse is "forward-pulse" according to chosen protocol in EEPROM (direction information is not valid at this time)
- Calibration phase 2
  - starts after "Calibration Phase 1"
  - lasts until the sensor has reached final offset-calibration which is minimum 5 teeth / maximum 64 teeth (pole-pairs) according to chosen algorithm in EEPROM
  - IC performs slow and accurate adaptation of the threshold according to the application magnetic field
  - output switching (calibrated mode) is performed according to magnetic zero-crossing of the differential magnetic field
  - length of the output-pulse is derived from the center Hall probe (direction signal) sampled at the zero-crossing of the differential outer Hall probes (speed signal)
- Running phase
  - starts after "Calibration Phase 2"
  - lasts indefinitely if no special condition is triggered (see **Chapter 3.7**)
  - performs a filter algorithm in order to maintain superior phase accuracy and improved jitter
  - output switches according to the threshold value, according to the hidden hysteresis algorithm and according to the chosen output-protocol

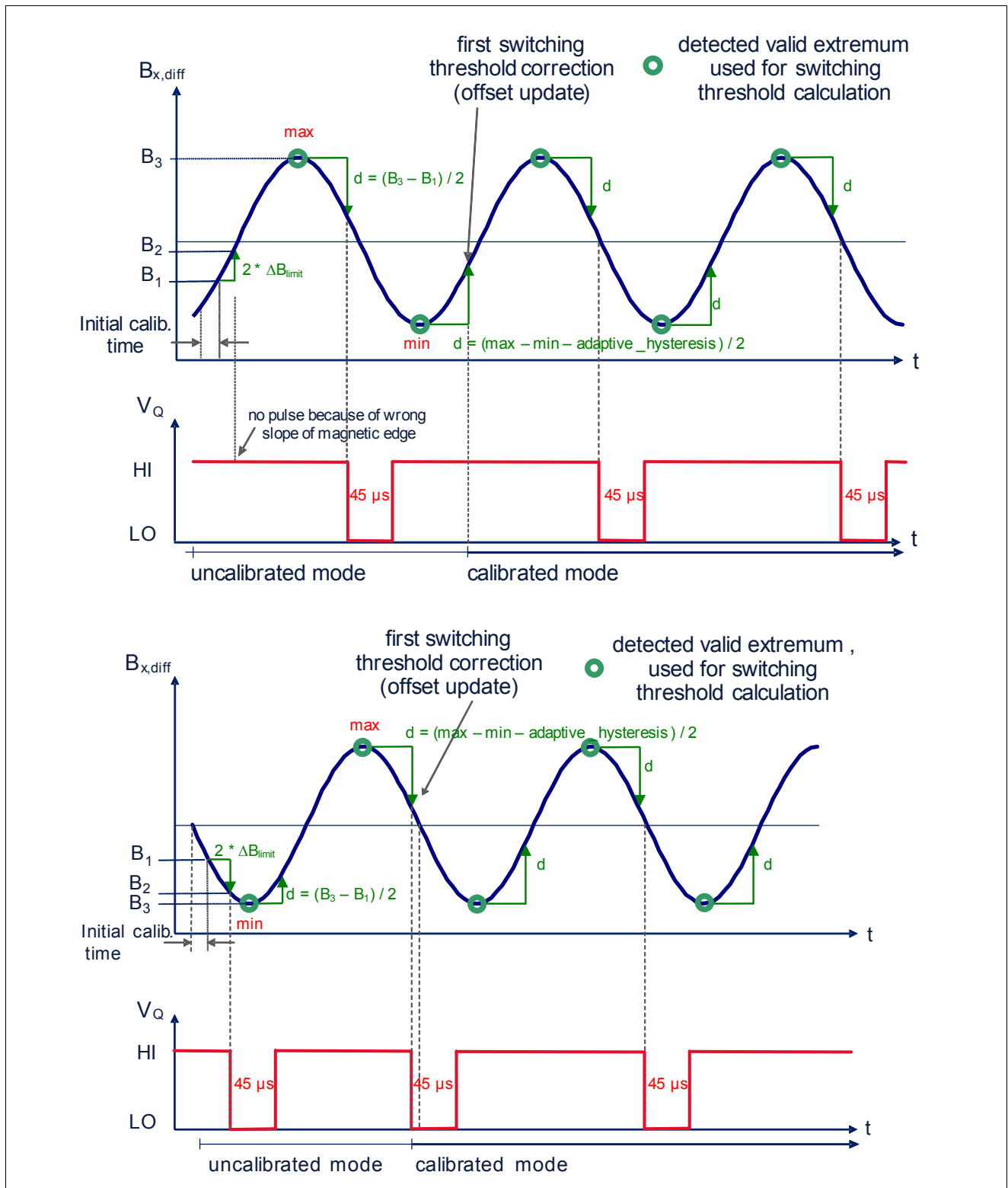

**Figure 5 Operating Phases - Power-on to Running Phase**

### 3.3.1 Power-on Phase

The operation in Power-on Phase is to refresh the trimming coefficients and algorithm settings from the EEPROM and to allow the signal path to stabilize.

If an unrecoverable error is found at EEPROM refresh, the output will remain locked HIGH during the entire operation.

### 3.3.2 Initial Phase

The magnetic field is measured by three chopped Hall probes. From the outer Hall probes located at a distance of 2.5mm a differential magnetic field is measured which is named “speed” in this datasheet. From the center Hall probe the “direction” signal is derived. Both signals are converted to a digital value via an ADC.

### 3.3.3 Calibration Phase

The adaptation of the threshold to the magnetic field is performed in Calibration Phase. This adaptation is done based on the field values set by teeth and notches (or based on poles on the pole wheel). These variations in the magnetic field are followed by a local extrema detection state machine in the IC. During Calibration Phase the IC permanently monitors the magnetic signal. First and second switching is performed when the speed-path recognized a certain change of magnetic field and the polarity meets the switching criterion derived from the EEPROM. The third and further pulse of the output is performed at “zero-crossing” of the speed path. “Zero crossing” is the 50%-value between detected minimum and detected maximum - also known as “offset”.

### 3.3.4 Running Phase

According to the chosen algorithm in EEPROM an average of 5 to 58 pulses is used to do an offset-calculation and an offset-update.

The following rules have to be verified before applying a computed update to the threshold register:

- Compatibility between threshold update sign and magnetic edge
- Threshold update has to be large enough not to be discarded (minimum\_update)
- Threshold update is limited to a maximum value based on field amplitude and on comparison with absolute field value (maximum\_update)
- Computed threshold update is always halved before being applied
- Threshold update is filtered to discourage consecutive updates in opposite direction (consecutive\_upd\_req)

Typically the offset is updated after one complete revolution of the target wheel, which is effectively 58 teeth.

**Table 5 Available offset update algorithm to be chosen in EEPROM**

Parameter	Symbol	Values			Unit	Note or Test Condition
		Min.	Typ.	Max.		
Offset update algorithm	58 teeth	-	58	-	-	one revolution of a 60-2 target
	32 teeth	-	32	-	-	one revolution of a 32-teeth /pole-pair target
	5 times the same sign for offset-update	5	-	-	-	suggested for wheels with different number of teeth or for large run-out.

### 3.3.5 Averaging Algorithm

To calculate the threshold within the running phase, valid maxima and minima are averaged to reduce possible offset-updates. Each offset-update gives an increased jitter, which has to be avoided.

### 3.3.6 Direction Detection

Direction is calculated from the amplitude-value of direction-signal sampled at zero-crossing of speed-channel. For each pole-pair or pair of tooth and notch two digital values are generated for detecting the direction. Subtracting the second value from the first value the direction is determined by its sign. According to EEPROM-setting a positive sign is either direction forward or direction backward.

**Table 6 EEPROM-options for polarity and direction**

EEPROM EDGE_POLAR	EEPROM FORWARD_DE F	Function
0	0	Forward-pulse is issued when wheel rotates from pin 1 to pin 3. Falling edge of output-pulse occurs at middle of the notch.
0	1	Forward-pulse is issued when wheel rotates from pin 3 to pin 1. Falling edge of output-pulse occurs at middle of the tooth. (as in TLE4929C-XAN-M28)
1	0	Forward-pulse is issued when wheel rotates from pin 1 to pin 3. Falling edge of output-pulse occurs at middle of the tooth.
1	1	Forward-pulse is issued when wheel rotates from pin 3 to pin 1. Falling edge of output-pulse occurs at middle of the notch.

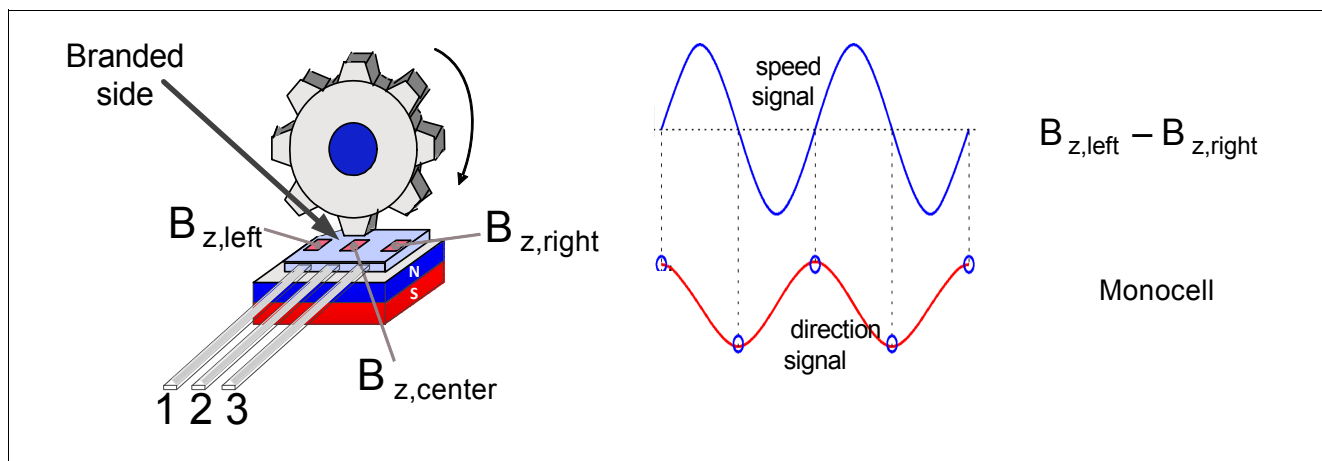

**Figure 6 Direction Detection Principle: TLE4929C-XAN-M28 issues forward-pulses at each middle of tooth**

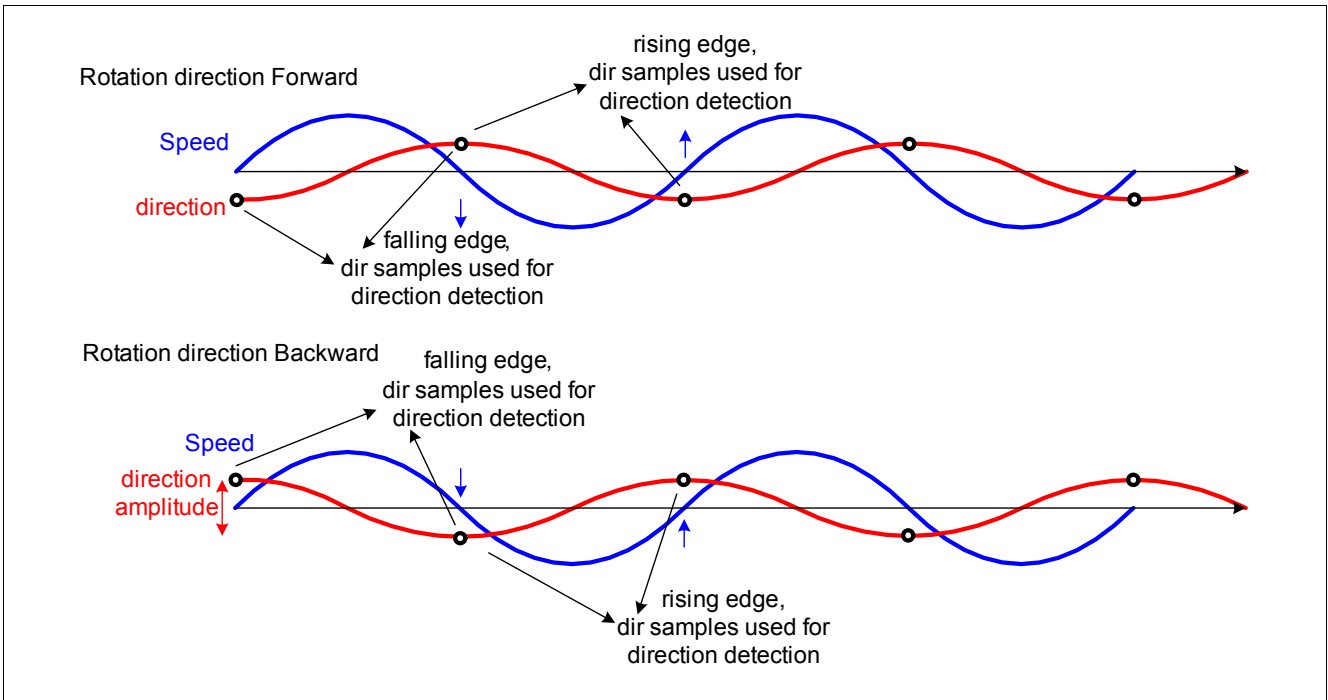

Figure 7 Direction Detection Principle: Rotation Direction Forward And Backward

### 3.3.7 Direction Detection Threshold

To recognize a change in rotational direction of the target wheel a threshold (Figure 8) is used. The peak-to-peak signal of direction is averaged over the last 5 teeth and is used as 100% value. Whenever a new minimum or a new maximum is measured, a threshold of 25% is calculated.

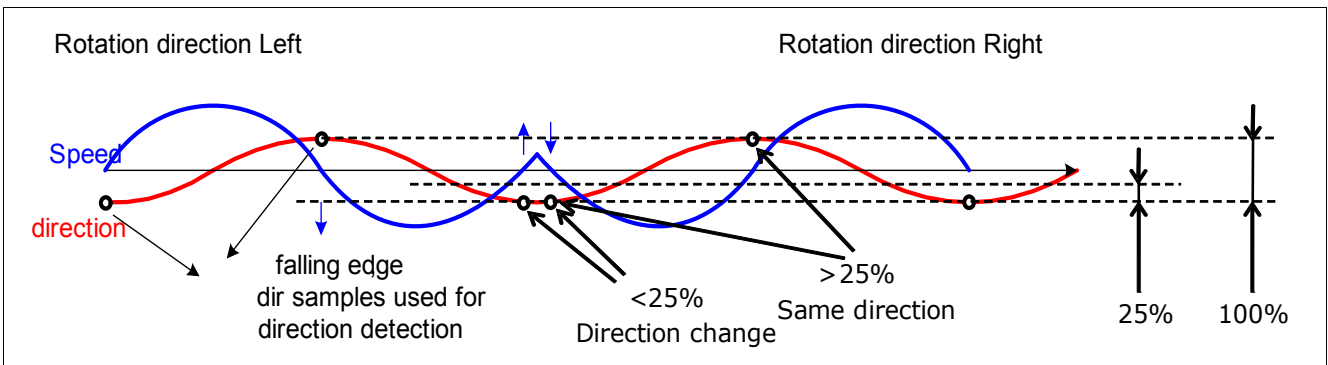
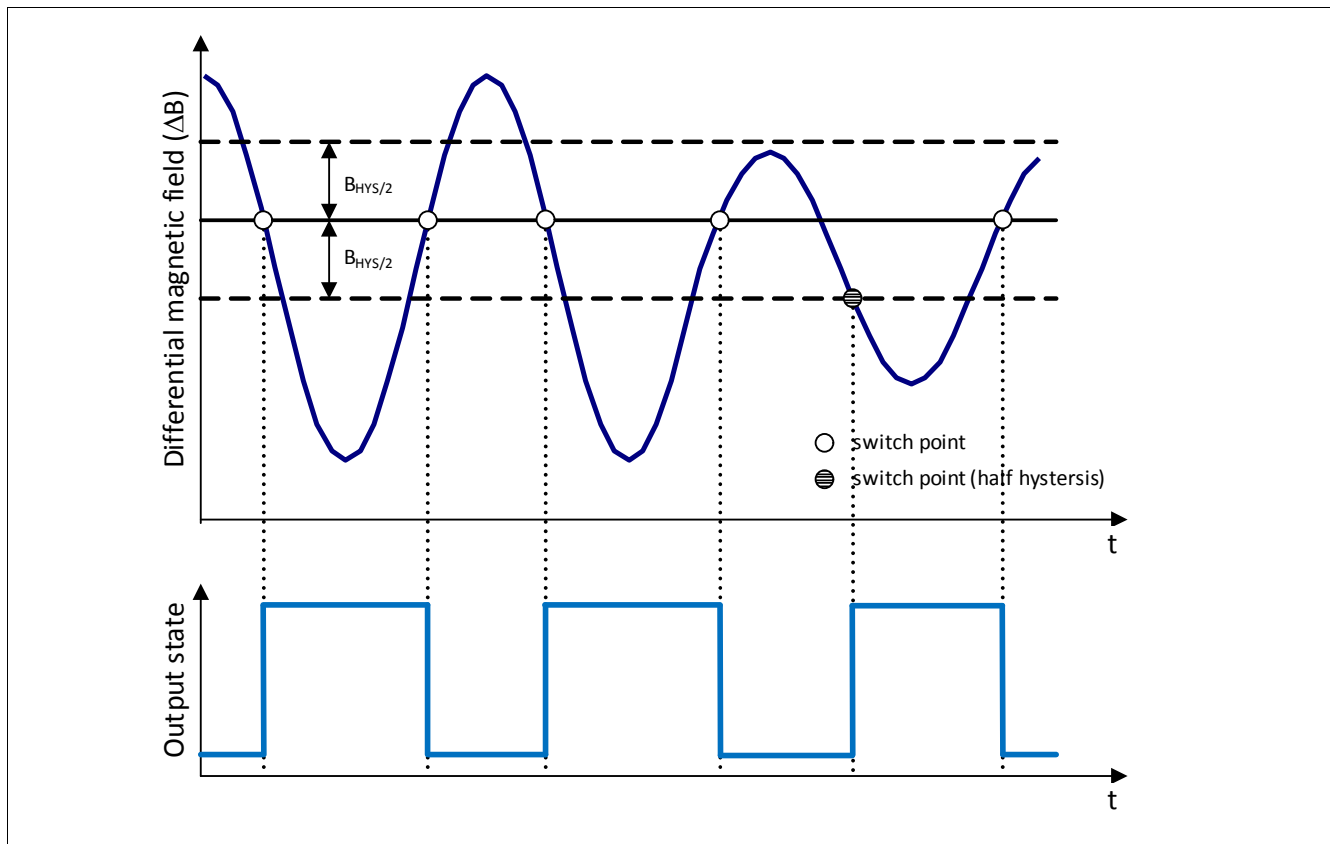

Figure 8 Direction Threshold Level

At a constant direction the next sample-point is expected to have another 100% signal amplitude. In the case of a rotational direction change the same value as before is expected. To distinguish between these two cases a virtual threshold of 25% is taken into account. Using EEPROM these 25% can be programmed to 12.5% (direction change criterion).

### 3.4 Hysteresis Concept



**Figure 9 Hidden Hysteresis in protocol-variant without direction detection**

The preferred switching behavior for crankshaft application in terms of hysteresis is called hidden adaptive hysteresis. For reason of long notches or long teeth there is the EEPROM possibility to go for visible hysteresis as well. Another EEPROM possibility is fixed hysteresis, which allows robustness against metallic flakes attached by the back-bias-magnet.

Hidden adaptive hysteresis means, the output always switches at the same level, centered between upper and lower hysteresis. These hysteresis thresholds needs to be exceeded and are used to enable the output for the next following switching event. For example, if the differential magnetic field crosses the lower hysteresis level, then the output is able to switch at the zero crossing. Next following upper hysteresis needs to be exceeded again in order to enable for the next switching. Furthermore, the function of half hysteresis maintains switching whenever the upper hysteresis level is not exceeded, but the lower hysteresis level is crossed again, then the output is allowed to switch, so that no edge is lost. However, this causes additional phase error, see [Figure 9](#).

Doing an adaptive hysteresis gives advantage at small airgap (large signal) to have big hysteresis. Compared with fixed hysteresis a small vibration cannot cause additional switching. According [Figure 10](#) the adaptive hysteresis is calculated as 25% of the differential Speed-signal peak to peak. The minimum hysteresis is derived from EEPROM-setting "HYST\_MIN".

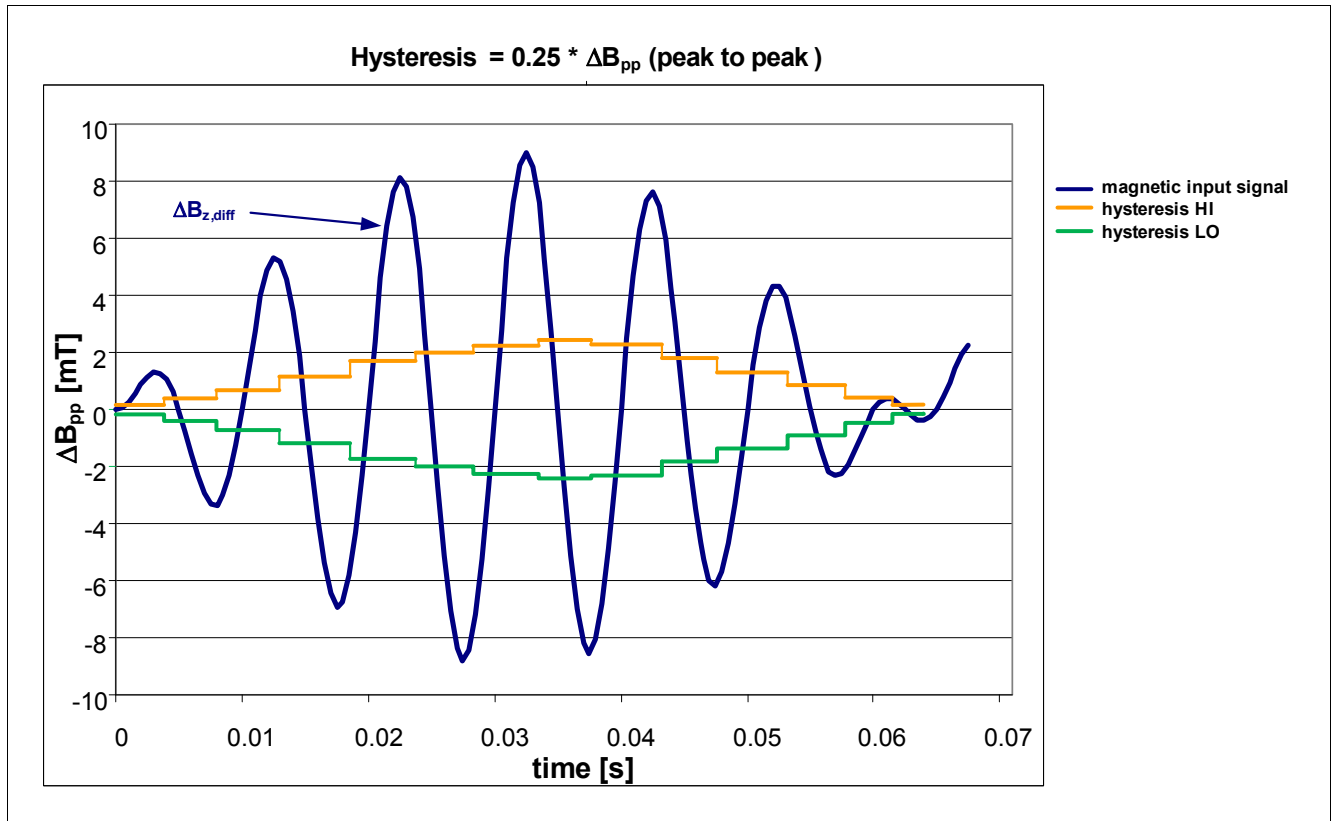

Figure 10 Adaptive Hysteresis

### 3.5 Rotational Direction Definition and Edge Polarity Definition

TLE4929C has EEPROM-options to change the position of the output-protocol. In the application the switching point is either the middle of the tooth or the middle of the notch (magnetic encoder wheel: middle of north pole or middle of south pole). From magnetic point of view it is zero crossing of the differential speed signal: Either rising edge or falling edge. The EEPROM-Bit “EDGE\_POLAR” parametrizes the sensor to one of the edges.

In addition there is an option to issue “forward”-pulses either in CW rotational direction or CCW rotational direction: “FORWARD\_DEF”.

Both EEPROM-bits are independent from each other.

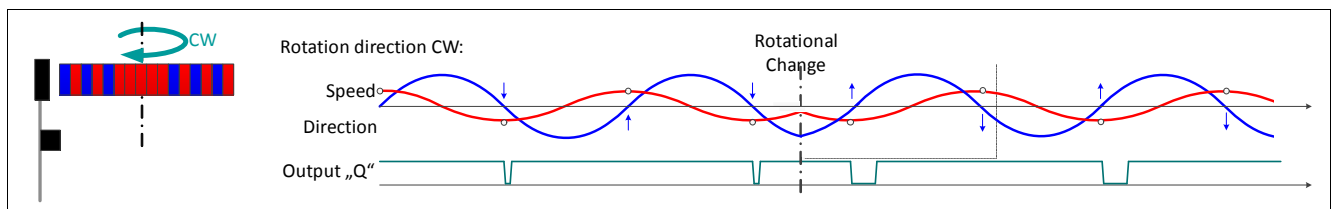
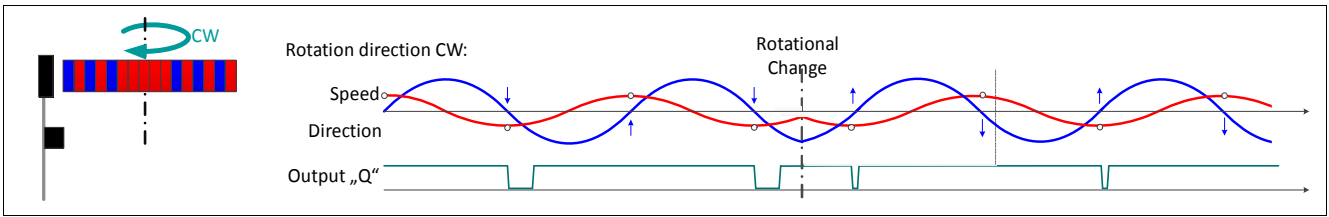
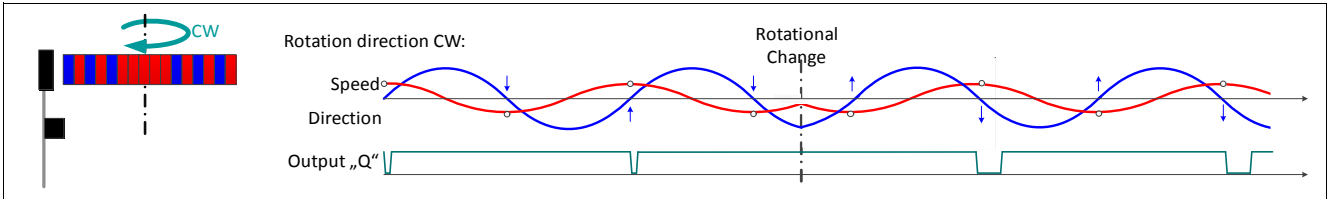

Figure 11 Signal output in setting “EDGE\_POLAR = 0” and “FORWARD\_DEF” = 0



**Figure 12** Signal output in setting “EDGE\_POLAR = 1” and “FORWARD\_DEF” = 1



**Figure 13** Signal output in setting “EDGE\_POLAR = 1” and “FORWARD\_DEF” = 0

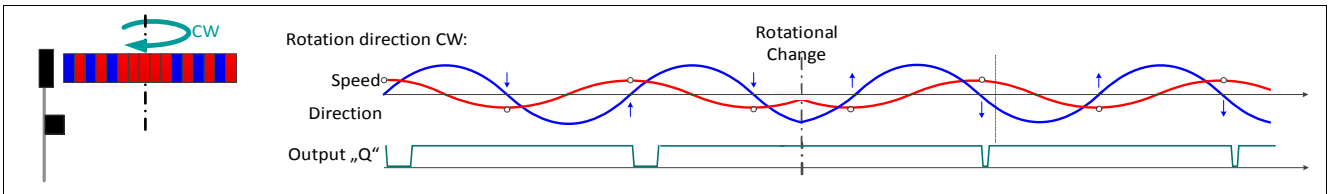

**Figure 14** Signal output in setting “EDGE\_POLAR = 0” and “FORWARD\_DEF” = 1

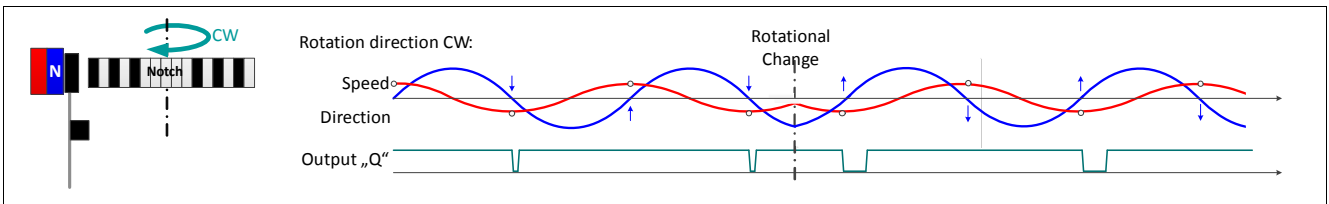

**Figure 15** Signal output in setting “EDGE\_POLAR = 0” and “FORWARD\_DEF” = 0

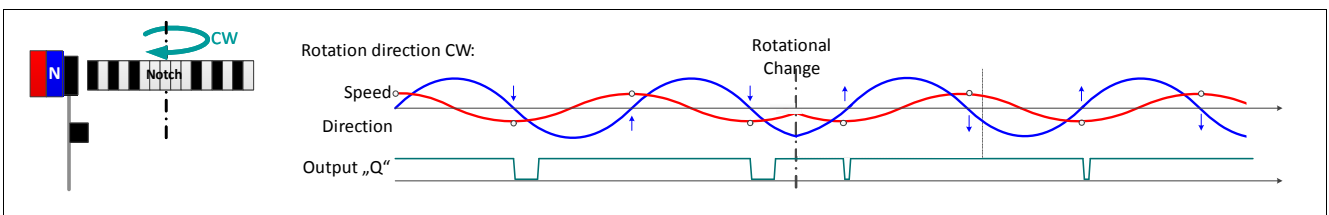

**Figure 16** Signal output in setting “EDGE\_POLAR = 1” and “FORWARD\_DEF” = 1

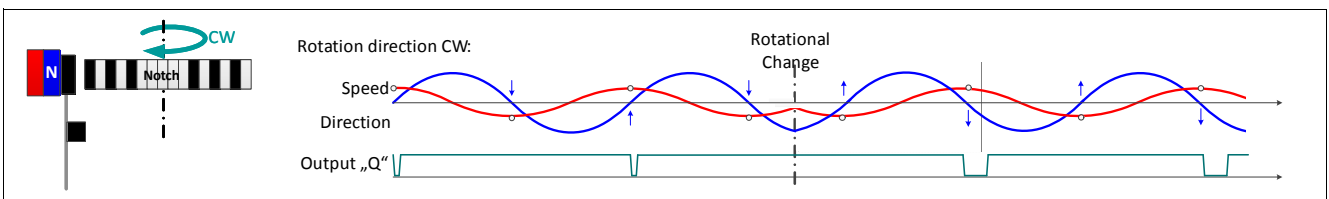

**Figure 17** Signal output in setting “EDGE\_POLAR = 1” and “FORWARD\_DEF” = 0

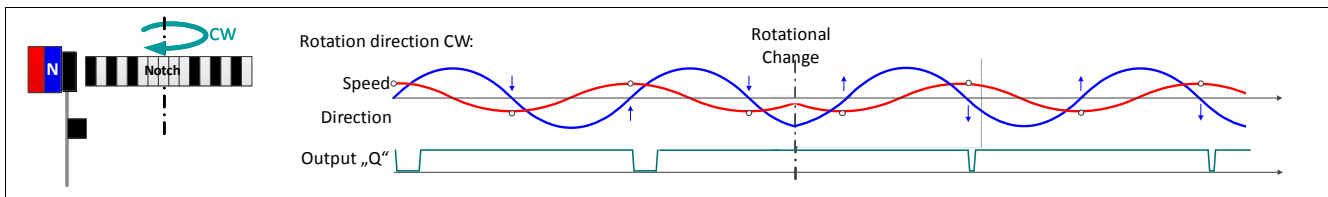

**Figure 18** Signal output in setting “EDGE\_POLAR = 0” and “FORWARD\_DEF” = 1

The TLE4929C is preprogrammed and has locked EEPROM. In **Figure 18** the behavior is pictured when following conditions are met:

- Backbias magnet is attached with magnetic north pole to the back of TLE4929C. (pictured in left part of **Figure 3**).
- Forward-pulses (crank forward pulse-length = 45µsec) are issued when toothed wheel moves from package-pin 3 (“Q”) to package-pin 1 (“VDD”).
- Backard-pulses (crank reverse pulse-length = 90µsec) are issued when toothed wheel moves from package-pin 1(“VDD”) to packape-pin 3 (“Q”).
- The pulse is issued in the middle of the tooth of the toothed wheel.

### 3.6 System Watchdog

The system watchdog is monitoring following parts in the digital core and at the output:

- Finding valid maxim in the speed signal
- Finding valid minim in the speed signal
- Finding valid zero-crossing of the speed signal
- Monitoring the output switching

As long the speed signal and the corresponding output switching is fine the system watchdog will reset itself automatically at every output-switching. As soon the system watchdog detects valid maximum, valid minimum and valid zero-crossing without a switching event at the output, the system watchdog will increase its counter. Switching of the output sets the counter to zero. When the counter reaches its limit the offset will be reset.

The advantage of this system watchdog is to avoid “flat line” behavior at the output. Once there happened a massive event in the sensing system (i.e. hit on the tooth, sudden air gap jump, ...), the TLE4929C is able to recover itself. The system watchdog can be enabled by EEPROM setting “WATCH\_DOG\_EN”.

### 3.7 Stop Start Watchdog

The Stop Start watchdog allows TLE4929C to stay calibrated as much as possible during stand-still of the target wheel and a possible temperature-drift of 60K. It can be enabled by EEPROM-option.

Basically the Stop Start watchdog is a time-out of 1.4 seconds. After 1.4 seconds time out between two zero crossing of the speed channel (crankshaft wheel stopped) the Stop Start Watchdog will enter active state. No output switching is enabled during active watchdog state. After a signal-change in speed channel above DNC within 1.4 seconds (crankshaft wheel rotates) the TLE4929C will use known signal-amplitude and perform output-switching with the new switching threshold at the new temperature.

At standstill of the target wheel the stop start watchdog will enable TLE4929C to not issue any wrong pulse at the output:

- No additional pulses
- No missing pulses

- No false rotational direction information

Combining the System Watchdog and the Stop Start Watchdog an immunity to vibration can be added to the Stop-Start-behavior.

Further details are available on request.

### **3.8 High Speed Mode**

The high speed mode can be switched on or off by EEPROM bit “HIGH\_SPEED”. Switched to state “off” the TLE4929x behaves as described. Switched to state “on” the TLE4929x stops direction detection above a certain input signal frequency of typically 1.8kHz and continues with the last detected direction. To switch to high speed mode the frequency has to be measured two times. Coming from high frequencies the direction detection is enabled again going below the frequency threshold of 1.5kHz.

In mode TSS = 1 the limits are 4.3kHz and 4.0kHz. All values are typical values.

### **3.9 Serial Interface**

The serial interface is used to set parameter and to program the sensor IC, it allows writing and reading of internal registers. Data transmission to the IC is done by supply voltage modulation, by providing the clock timing and data information via only one line. Data from the IC are delivered via the output line, triggered by as well clocking the supply line. In normal application operation the interface is not active, for entering that mode a certain command right after power-on is required.

A detailed interface document (TLE4929Cx/59x EEPROM Programming Guide) is available on request, containing description of electrical timing and voltage requirements, as well as information about data protocol, available registers and addresses.

## 4 EEPROM Description

Several options of TLE4929C can be programmed via an EEPROM to optimize the sensor algorithm to the individual target wheel and application requirements. The EEPROM memory is organized in 2 customer lines, whereas each line is composed of 16 data bits and additional 6 bits for error detection and correction, based on ECC (Error Correction Code). For more detailed information about EEPROM access and programming an EEPROM Programming manual is available.

**Table 7 Temperature-Compensation for used magnetic material**

Type	Description	TC (typical)	fits magnetic material
TLE4929C-XAN-M28	EEPROM pre programmed and locked	-825 ppm	SmCo, NdFeB
TLE4929C-XAF-M28	EEPROM unlocked	-1400 ppm	NdFeB, Fe

**Table 8 EEPROM Address 0x0**

15	14	13	12	11	10	9	8	7	6	5	4	3	2	1	0
customer line #1															

**Table 9 Functional Description Address 0x0**

Field	Bit	Type	Description	TLE4929C -XAN-M28	TLE4929C -XAF-M28
not used	15	r	always read as "0"	0	0
STOP_ENABLE	14	rw	0 = Disable stop mode 1 = Enable stop mode	1	1
HIGH_SPEED	13	rw	0 = Enabled motion detection 1 = Same pulse and phase as before when above 1.5kHz	1	1
DIR_CHANGE	12	rw	0 = 1/4 Criteria for direction change 1 = 1/8 Criteria for direction change	0	0
WATCH_DOG_EN	11	rw	0 = Watchdog off 1 = Watchdog on	0	0
not used	10..2	rw	to be set to "000000000"	000000000	000000000
PULSE_WIDTH	1	rw	0 = Default pulse length for all pulses 1 = All pulses shortened by 4µs (GM-pullup)	0	0
POLE_WHEEL	0	rw	0 = Back bias self calibration on startup – back bias applications 1 = Back bias in center and differential path set to ~0mT	0	1

**Table 10 EEPROM Address 0x1**

15	14	13	12	11	10	9	8	7	6	5	4	3	2	1	0
customer line #2															

**Table 11 Functional Description Address 0x1**

Field	Bit	Type	Description	TLE4929C -XAN-M28	TLE4929C -XAF-M28
not used	15:14	rw	to be set to "0"	00	00
PW_CHOICE	13	rw	Choice of pulse length at direction detection forwards/backwards time, pulse length is 3µs shorter by default and can be shortened by additional 4µs with the PULSE_WIDTH bit. Details please find on <a href="#">Table 4</a> . 0 = 45 / 90µs 1 = 45 / 135µs	0	0
not used	12	rw	to be set to "0"	0	0
FORWARD_DEF	11	rw	0 = none inversion of forward definition 1 = inversion of forward definition	1	0
EDGE_POLAR	10	rw	0 = non-inverted 1 = inverted	0	1
HYST_ADAPT	9	rw	0 = 25% 1 = 31.25%	0	0
HYST	8	rw	0 = 0.75mTpkpk 1 = 1.5mTpkpk	1	1
HYST_TYPE	7	rw	0 = Hidden adaptive hysteresis 1 = Visible adaptive hysteresis	0	0
DNC_MIN	6:5	rw	Minimal DNC (Digital Noise Constant): 00 = 0.75mTpkpk 01 = 1.5mTpkpk 10 = 2.5mTpkpk 11 = 5mTpkpk	01	01
DNC_ADAPT	4	rw	Following value is used for uncalibrated mode: 0 = 25% 1 = 31.5%	0	0
CRANK_TEETH	3	rw	0 = 58 teeth 1 = 32 teeth	0	0
DIR_ENABLE	2	rw	0 = Direction detection off 1 = Direction detection on	1	1
ADAPT_FILT	1	rw	0 = Slow adaptation tracking: average over 32/58 (CRANK_TEETH) edges... 1 = Fast adaptation tracking: Each valid min/max is considered and allows a small offset-update. When the last 5 updates have the same sign a full offset-update will be performed.	0	0
LOCK	0	rw	0 = User area of EEPROM is unlocked 1 = User area of EEPROM is locked (no reprogramming possible)	1	0

## 5 Package Information

Pure tin covering (green lead plating) is used. The product is RoHS (Restriction of Hazardous Substances) compliant and marked with letter G in front of the data code marking and contains a data matrix code on the rear side of the package (see also information note 136/03). Please refer to your key account team or regional sales if you need further information.

The specification for soldering and welding is defined in the latest revision of application note “Recommendation for Handling and Assembly of Infineon PG-SSO Sensor Packages”.

Position tolerance of sensing elements has CpK > 1.67 in both dimensions.

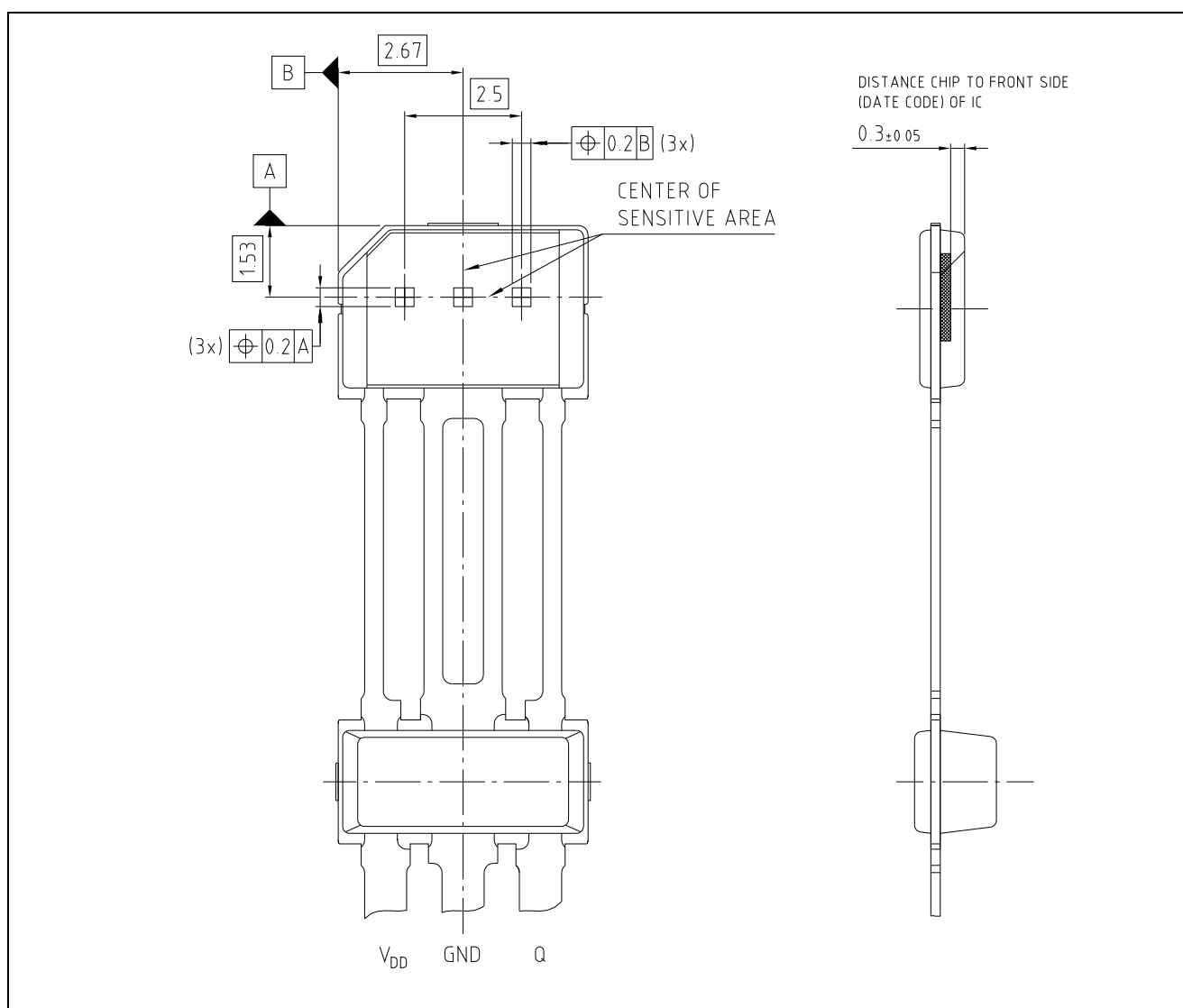

**Figure 19 Pin Configuration and Sensitive Area / Position of the Hall Elements in PG-SSO-3-5x and Distance to the Branded Side**

**Table 12 Pin Description**

Pin Number	Symbol	Function
1	$V_{DD}$	Supply Voltage
2	GND	Ground
3	Q	Open Drain Output



## 5.2 Marking and Data Matrix Code

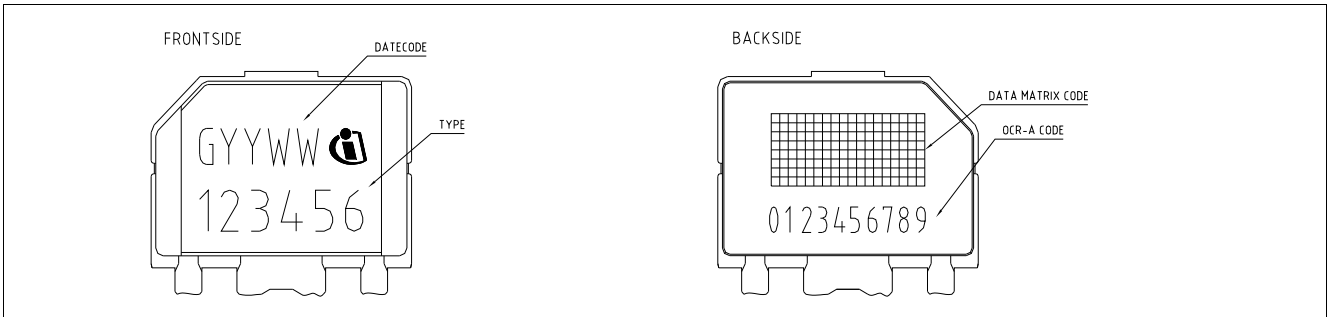

Figure 21 Marking of PG-SSO-3-5x Package

## 5.3 Packing Information

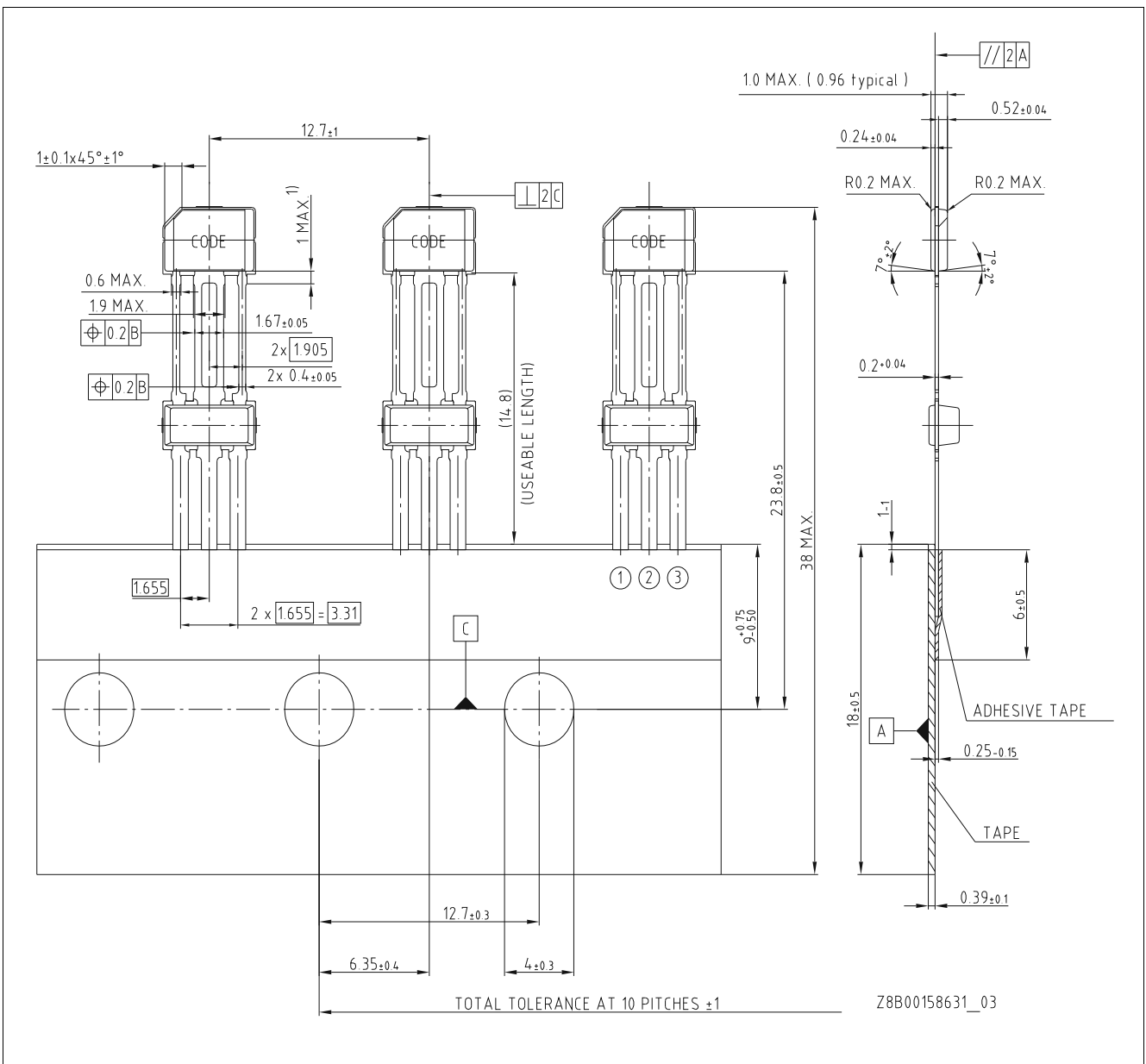

Figure 22 PG-SSO-3-5x Ammpack

## **6 Revision History**

<b>Revision</b>	<b>Date</b>	<b>Changes</b>
1.0	2018-02-01	Initial Version of Datasheet
1.1	2018-09-13	Additional drawings in chapter functional description / editorial changes

#### Trademarks of Infineon Technologies AG

$\mu$ HVIC™,  $\mu$ IPM™,  $\mu$ PFC™, AU-ConvertIR™, AURIX™, C166™, CanPAK™, CIPOS™, CIPURSE™, CoolDP™, CoolGaN™, COOLiR™, CoolMOS™, CoolSET™, CoolSiC™, DAVE™, DI-POL™, DirectFET™, DrBlade™, EasyPIM™, EconoBRIDGE™, EconoDUAL™, EconoPACK™, EconoPIM™, EiceDRIVER™, eupec™, FCOS™, GaNpowIR™, HEXFET™, HITFET™, HybridPACK™, iMOTION™, IRAM™, ISOFACE™, IsoPACK™, LEDriviR™, LITIX™, MIPAQ™, ModSTACK™, my-d™, NovalithIC™, OPTIGA™, OptiMOS™, ORIGA™, PowIRaudio™, PowIRstage™, PrimePACK™, PrimeSTACK™, PROFET™, PRO-SIL™, RASIC™, REAL3™, SmartLEWIS™, SOLID FLASH™, SPOC™, StrongIRFET™, SupIRBuck™, TEMPFET™, TRENCHSTOP™, TriCore™, UHVIC™, XHP™, XMC™.

Trademarks updated November 2015

#### Other Trademarks

All referenced product or service names and trademarks are the property of their respective owners.

**Edition 2018-09-13**

**Published by**

**Infineon Technologies AG**

**81726 Munich, Germany**

**© 9/27/18 Infineon Technologies AG.**

**All Rights Reserved.**

**Do you have a question about any aspect of this document?**

**Email: [erratum@infineon.com](mailto:erratum@infineon.com)**

#### IMPORTANT NOTICE

The information given in this document shall in no event be regarded as a guarantee of conditions or characteristics ("Beschaffheitsgarantie").

With respect to any examples, hints or any typical values stated herein and/or any information regarding the application of the product, Infineon Technologies hereby disclaims any and all warranties and liabilities of any kind, including without limitation warranties of non-infringement of intellectual property rights of any third party.

In addition, any information given in this document is subject to customer's compliance with its obligations stated in this document and any applicable legal requirements, norms and standards concerning customer's products and any use of the product of Infineon Technologies in customer's applications.

The data contained in this document is exclusively intended for technically trained staff. It is the responsibility of customer's technical departments to evaluate the suitability of the product for the intended application and the completeness of the product information given in this document with respect to such application.

For further information on technology, delivery terms and conditions and prices, please contact the nearest Infineon Technologies Office ([www.infineon.com](http://www.infineon.com)).

#### WARNINGS

Due to technical requirements products may contain dangerous substances. For information on the types in question please contact your nearest Infineon Technologies office.

Except as otherwise explicitly approved by Infineon Technologies in a written document signed by authorized representatives of Infineon Technologies, Infineon Technologies' products may not be used in any applications where a failure of the product or any consequences of the use thereof can reasonably be expected to result in personal injury.