

TLE4998S3C

Programmable Linear Hall Sensor

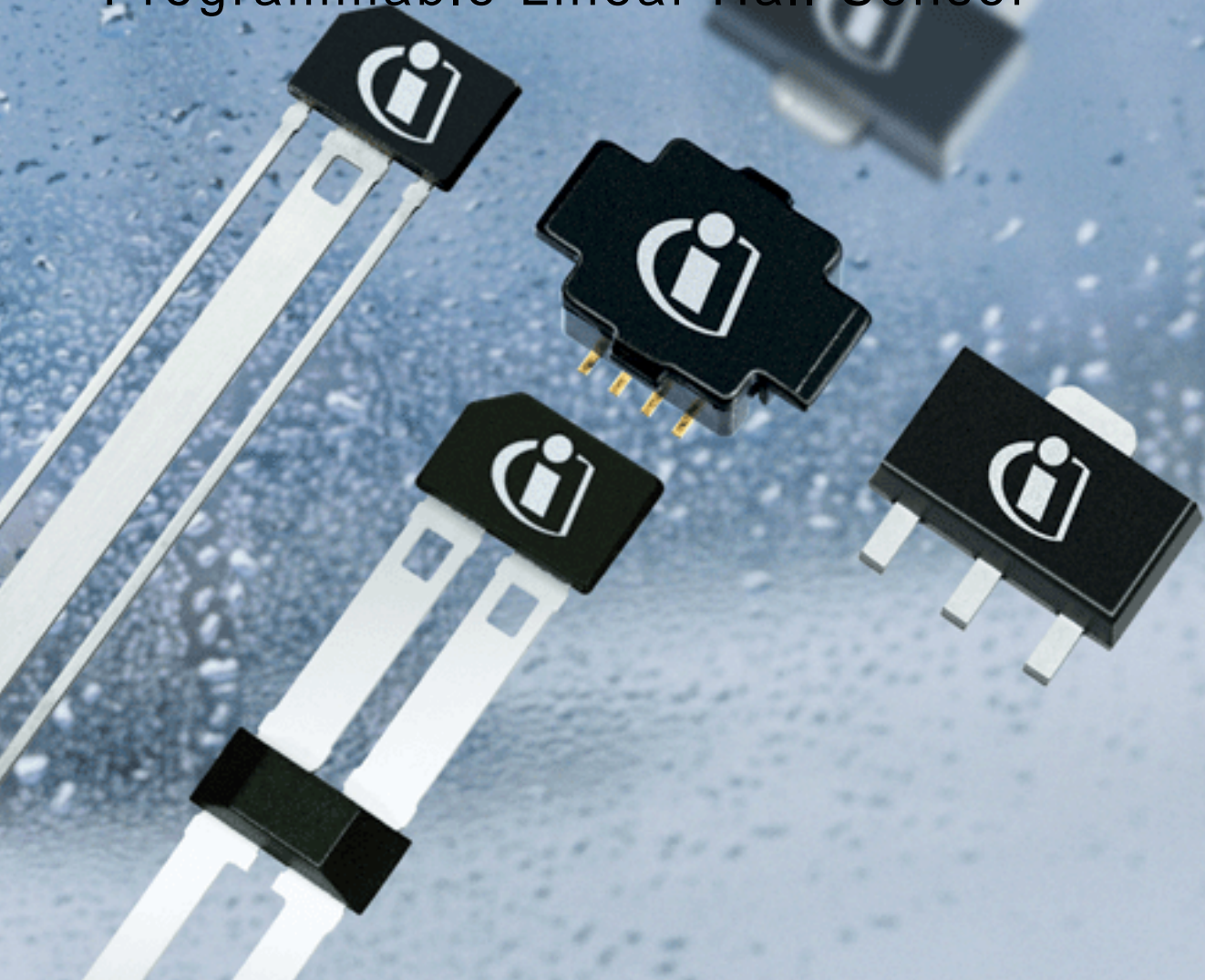

Sensors



Never stop thinking.

Edition 2009-09

**Published by Infineon Technologies AG,
Am Campeon 1-12,
85579 Neubiberg, Germany**

**© Infineon Technologies AG 2009.
All Rights Reserved.**

Attention please!

The information herein is given to describe certain components and shall not be considered as a guarantee of characteristics.

Terms of delivery and rights to technical change reserved.

We hereby disclaim any and all warranties, including but not limited to warranties of non-infringement, regarding circuits, descriptions and charts stated herein.

Information

For further information on technology, delivery terms and conditions and prices please contact your nearest Infineon Technologies Office (www.infineon.com).

Warnings

Due to technical requirements components may contain dangerous substances. For information on the types in question please contact your nearest Infineon Technologies Office.

Infineon Technologies Components may only be used in life-support devices or systems with the express written approval of Infineon Technologies, if a failure of such components can reasonably be expected to cause the failure of that life-support device or system, or to affect the safety or effectiveness of that device or system. Life support devices or systems are intended to be implanted in the human body, or to support and/or maintain and sustain and/or protect human life. If they fail, it is reasonable to assume that the health of the user or other persons may be endangered.

TLE4998S3C

Revision History: **2009-09**

Rev 1.1

Previous Version: Data Sheet Rev 1.0

Page	Subjects (major changes since last revision)
Page 12	Table 4: Footnote 3) adapted
Page 14	Table 5: Sensitivity drift description adapted
Page 14	Table 5: Footnote 3) adapted
Page 24	Table 14: Footnote 1) and 2) adapted
General	Package nomenclature changed to PG-SSO-3-92

<p>We Listen to Your Comments</p> <p>Any information within this document that you feel is wrong, unclear or missing at all? Your feedback will help us to continuously improve the quality of this document. Please send your proposal (including a reference to this document) to: sensors@infineon.com</p>	
--	---

1	Overview	5
1.1	Features	5
1.2	Target Applications	6
1.3	Pin Configuration	6
2	General	7
2.1	Block Diagram	7
2.2	Functional Description	7
2.3	Principle of Operation	8
2.4	Transfer Functions	9
3	Maximum Ratings	10
4	Operating Range	11
5	Electrical, Thermal, and Magnetic Parameters	12
	Calculation of the Junction Temperature	14
	Magnetic Parameters	14
6	Signal Processing	16
	Magnetic Field Path	16
	Temperature Compensation	16
6.1	Magnetic Field Ranges	17
6.2	Gain Setting	18
6.3	Offset Setting	18
6.4	DSP Input Low-Pass Filter	19
6.5	Clamping	21
7	Error Detection	23
7.1	Voltages Outside the Operating Range	23
7.2	EEPROM Error Correction	23
8	Temperature Compensation	24
8.1	Parameter Calculation	25
9	Calibration	26
9.1	Calibration Data Memory	27
9.2	Programming Interface	28
9.3	Data Transfer Protocol	28
9.4	Programming of Sensors with Common Supply Lines	28
10	Application Circuit	29
11	PG-SSO-3-92 Package Outlines	30
12	SENT Output Definition (SAE J2716)	31
12.1	Basic SENT Protocol Definition	31
12.2	Unit Time Setup	32
12.3	Checksum Nibble Details	35

1 Overview

1.1 Features

- Single Edge Nibble Transmission (SENT) open-drain output signal (SAE J2716)
- 20-bit Digital Signal Processing (DSP)
- Digital temperature compensation
- 16-bit overall resolution
- Operates within automotive temperature range
- Low drift of output signal over temperature and lifetime
- Programmable parameters stored in EEPROM with single-bit error correction:
 - SENT unit time
 - Magnetic range and sensitivity (gain), polarity of the output slope
 - Offset
 - Bandwidth
 - Clamping levels
 - Customer temperature compensation coefficients
 - Memory lock
- Re-programmable until memory lock
- Supply voltage 4.5 - 5.5 V (4.1 - 16 V extended range)
- Operation between -200 mT and +200 mT within three ranges
- Reverse-polarity and overvoltage protection for all pins
- Output short-circuit protection
- On-board diagnostics (overvoltage, EEPROM error, start up)
- Output of internal magnetic field values and temperature
- Programming and operation of multiple sensors with common power supply
- Two-point calibration of magnetic transfer function without iteration steps
- High immunity against mechanical stress, EMC, ESD
- Package with two capacitors: 47nF (*VDD* to *GND*) and 4.7nF (*OUT* to *GND*)

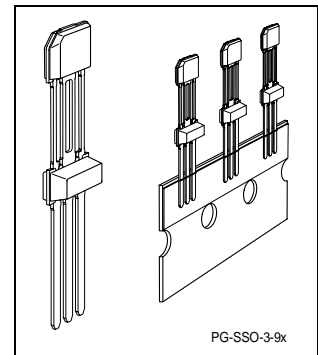

Type	Marking	Ordering Code	Package
TLE4998S3C	98S3C	SP000481484	PG-SSO-3-92

1.2 Target Applications

- Robust replacement of potentiometers
 - No mechanical abrasion
 - Resistant to humidity, temperature, pollution and vibration
- Linear and angular position sensing in automotive applications such as pedal position, suspension control, throttle position, headlight levelling, and steering torque sensing
- Sensing of high current for battery management, motor control, and electronic fuses

1.3 Pin Configuration

Figure 1 shows the location of the Hall element in the chip and the distance between Hall probe and the surface of the package.

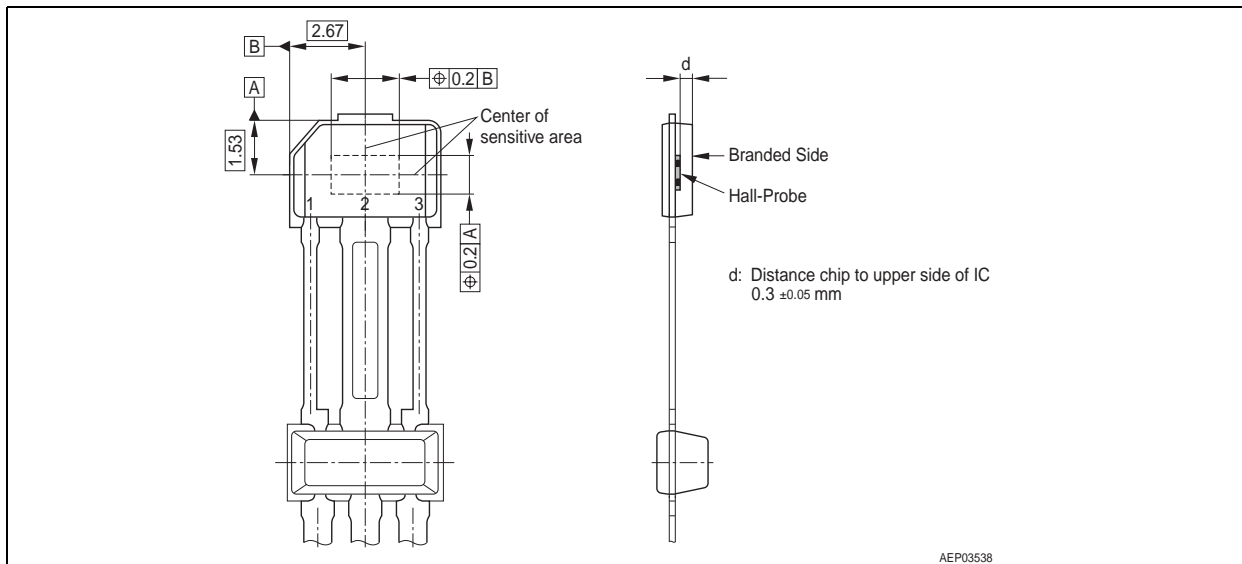

Figure 1 TLE4998x3C Pin Configuration and Hall Cell Location

Table 1 TLE4998S3C Pin Definitions and Functions

Pin No.	Symbol	Function
1	<i>VDD</i>	Supply voltage / programming interface
2	<i>GND</i>	Ground
3	<i>OUT</i>	Output / programming interface

2 General

2.1 Block Diagram

Figure 2 is a simplified block diagram.

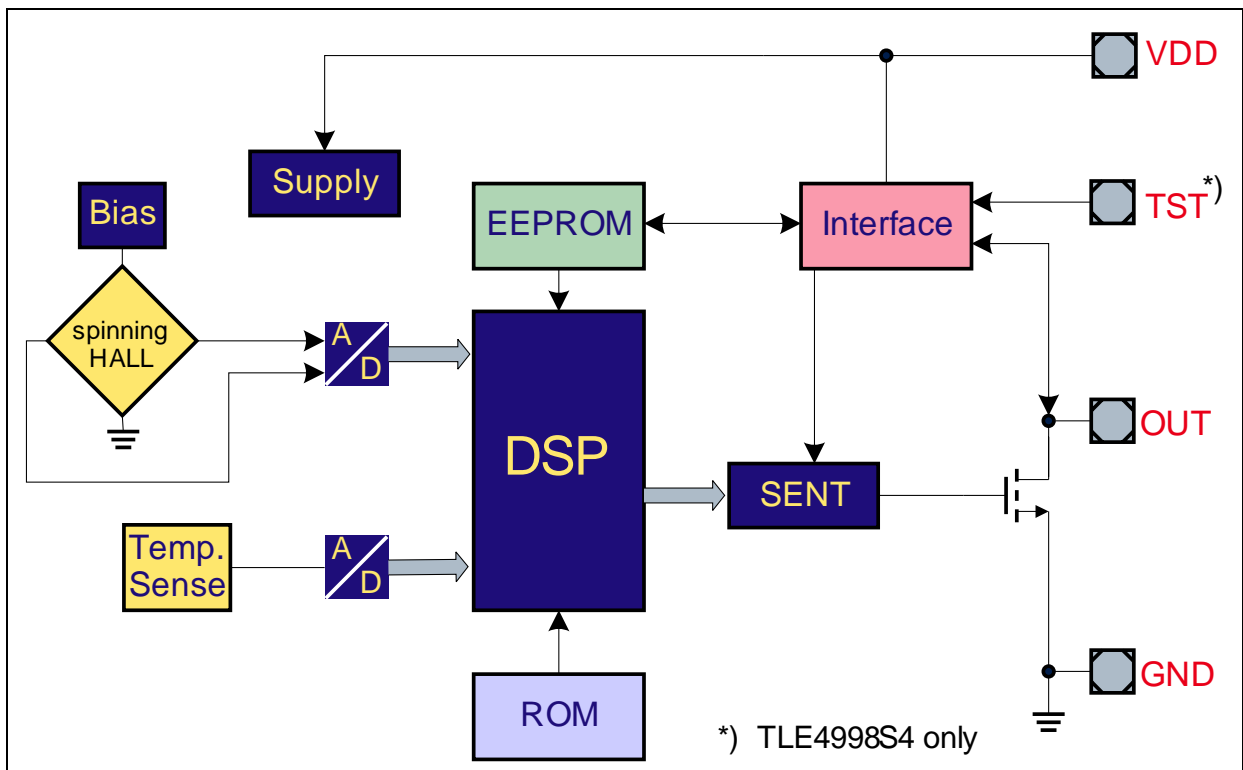

Figure 2 Block Diagram

2.2 Functional Description

The linear Hall IC TLE4998S3C has been designed specifically to meet the requirements of highly accurate rotation and position detection, as well as for current measurement applications. Two capacitors are integrated on the lead frame, making this sensor especially suitable for applications with demanding EMC requirements.

The sensor provides a digital SENT signal based on the SAE J2716 standard, which consists of a sequence of pulses. Each transmission has a constant number of nibbles containing the Hall value, the temperature, and status information of the sensor. The output stage is an open-drain driver pulling the output pin to low only. Therefore, the high level needs to be obtained by an external pull-up resistor. This output type has the advantage that the receiver may use an even lower supply voltage (e.g. 3.3 V). In this case the pull-up resistor must be connected to the given receiver supply.

General

The IC is produced in BiCMOS technology with high voltage capability, and it also has reverse-polarity protection.

Digital signal processing using a 16-bit DSP architecture together with digital temperature compensation guarantee excellent long-time stability compared to analog compensation methods.

While the overall resolution is 16 bits, some internal stages work with resolutions up to 20 bits.

2.3 Principle of Operation

- A magnetic flux is measured by a Hall-effect cell
- The output signal from the Hall-effect cell is converted from analog to digital
- The chopped Hall-effect cell and continuous-time A/D conversion ensure a very low and stable magnetic offset
- A programmable low-pass filter to reduce noise
- The temperature is measured and A/D converted, too
- Temperature compensation is done digitally using a second-order function
- Digital processing of output value is based on zero field and sensitivity value
- The output value range can be clamped by digital limiters
- The final output value is represented by the data nibbles of the SENT protocol

2.4 Transfer Functions

The examples in **Figure 3** show how different magnetic field ranges can be mapped to the desired output value ranges.

- Polarity Mode:
 - **Bipolar:** Magnetic fields can be measured in both orientations. The limit points do not necessarily have to be symmetrical around the zero field point
 - **Unipolar:** Only north- or south-oriented magnetic fields are measured
- Inversion: The gain can be set to both positive and negative values

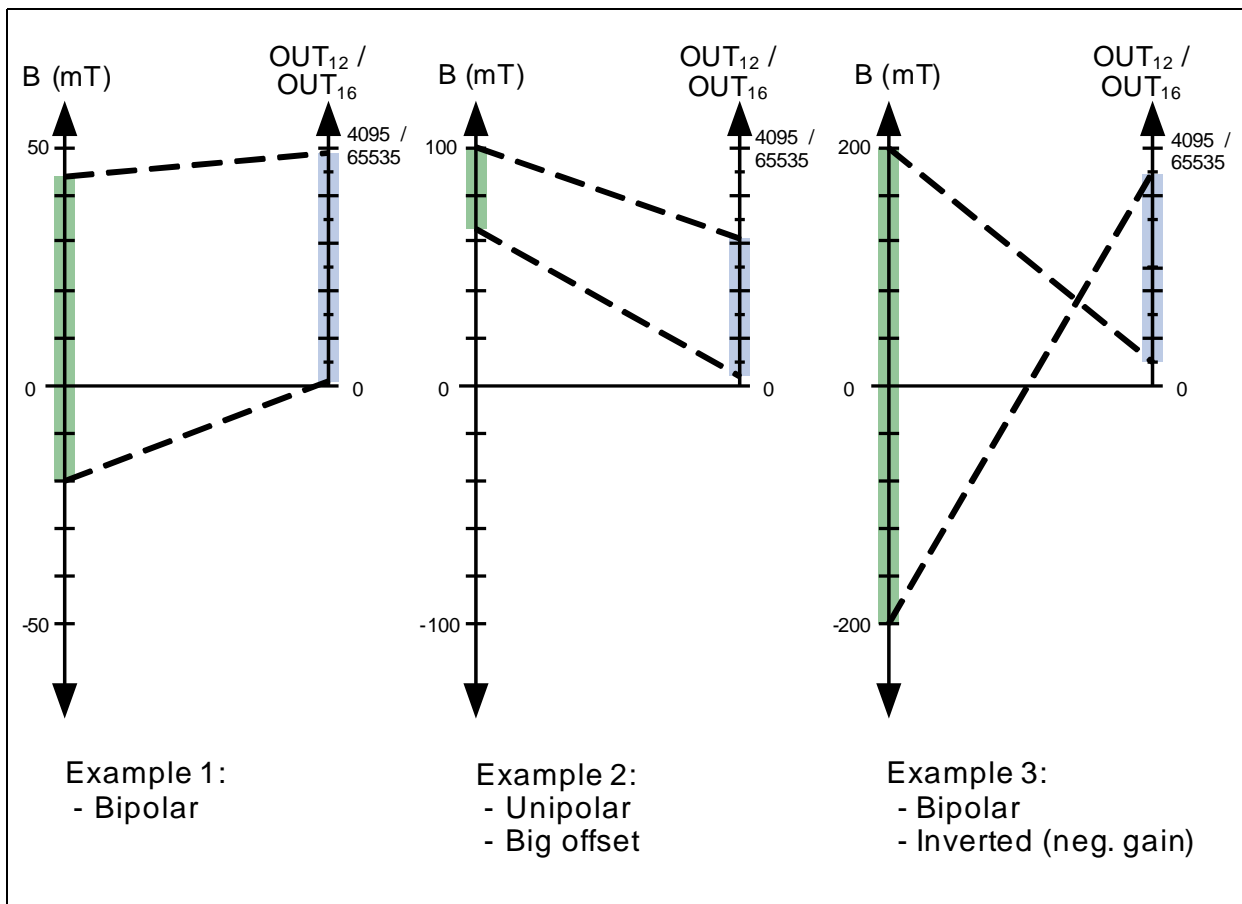

Figure 3 Examples of Operation

3 Maximum Ratings

Table 2 Absolute Maximum Ratings

Parameter	Symbol	Limit Values		Unit	Notes
		min.	max.		
Storage temperature	T_{ST}	- 40	150	°C	
Junction temperature	T_J	- 40	170 ¹⁾	°C	
Voltage on V_{DD} pin with respect to ground	V_{DD}	-18	18	V	2)
Supply current @ overvoltage V_{DD} max.	I_{DDov}	-	15	mA	
Reverse supply current @ V_{DD} min.	I_{DDrev}	-1	0	mA	
Voltage on output pin with respect to ground	V_{OUT}	-1 ³⁾	18 ⁴⁾	V	
Magnetic field	B_{MAX}	-	unlimited	T	
ESD protection	V_{ESD}	-	8	kV	According HBM JESD22-A114-B ⁵⁾

1) For limited time of 96 h. Depends on customer temperature lifetime cycles. Please ask for support by Infineon

2) Higher voltage stress than absolute maximum rating, e.g. 150% in latch-up tests is not applicable. In such cases, $R_{series} \geq 100 \Omega$ for current limitation is required

3) I_{DD} can exceed 10 mA when the voltage on OUT is pulled below -1 V (-5 V at room temperature)

4) $V_{DD} = 5$ V, open drain permanent low, for max. 10 minutes

5) 100 pF and 1.5 k Ω

Note: Stresses above those listed under “Absolute Maximum Ratings” may cause permanent damage to the device. This is a stress rating only and functional operation of the device at these or any other conditions above those indicated in the operational sections of this specification is not implied.

Exposure to absolute maximum rating conditions for extended periods may affect device reliability.

4 Operating Range

The following operating conditions must not be exceeded in order to ensure correct operation of the TLE4998S3C. All parameters specified in the following sections refer to these operating conditions, unless otherwise indicated.

Table 3 Operating Range

Parameter	Symbol	Limit Values		Unit	Notes
		min.	max.		
Supply voltage	V_{DD}	4.5	5.5	V	
		4.1 ¹⁾	16 ²⁾	V	Extended range
Output pull-up voltage ³⁾	$V_{pull-up}$	-	18	V	
Load resistance ³⁾	R_L	1	-	k Ω	
Output current ³⁾	I_{OUT}	0	5	mA	
Junction temperature	T_J	- 40	125 150 ⁴⁾	°C	For 5000 h For 1000 h not additive

1) For reduced output accuracy

2) For supply voltages > 12 V, a series resistance $R_{series} \geq 100 \Omega$ is recommended

3) Output protocol characteristics depend on these parameters, R_L must be according to max. output current

4) For reduced magnetic accuracy; extended limits are taken for characteristics

Keeping signal levels within the limits specified in this table ensures operation without overload conditions.

Electrical, Thermal, and Magnetic Parameters
5 Electrical, Thermal, and Magnetic Parameters
Table 4 Electrical Characteristics

Parameter	Symbol	Limit Values			Unit	Notes
		min.	typ.	max.		
VDD-GND capacitor	C_{VDD}	-	47	-	nF	Ceramic
OUT-GND capacitor	C_L	-	4.7	-	nF	Ceramic
SENT transmission time	t_{SENT}	-	-	1	ms	1)
Supply current	I_{DD}	3	6	8	mA	
Output current @ OUT shorted to supply lines	I_{OUTsh}	-	95	-	mA	$V_{OUT} = 5\text{ V}$, max. 10 minutes
Thermal resistance	R_{thJA}	-	190	-	K/W	Junction to air
	R_{thJC}	-	41	-	K/W	Junction to case
Power-on time ²⁾	t_{Pon}	-	0.7 15	2 20	ms	$\leq \pm 5\%$ target out value $\leq \pm 1\%$ target out value
Power-on reset level	V_{DDpon}	-	3.6	4	V	
Output impedance	Z_{OUT}	19	30	44	k Ω	3)
Output fall time	t_{fall}	2	-	4	μs	V_{OUT} 4.5 V to 0.5 V ⁴⁾
Output rise time	t_{rise}	-	20	-	μs	V_{OUT} 0.5 V to 4.5 V ⁴⁾⁵⁾
Output low saturation voltage	V_{OUTsat}	-	0.3 0.2	0.6 0.4	V	$I_{OUTsink} = 5\text{ mA}$ $I_{OUTsink} = 2.2\text{ mA}$
Output noise (rms)	OUT_{noise}	-	1	2.5	LSB ₁₂	6)

- 1) Transmission time depends on the data values being sent and on int. RC oscillator freq. variation of +/- 20%
- 2) Response time to set up output data at power on when a constant field is applied. The first value given has a $\pm 5\%$ error, the second value has a $\pm 1\%$ error. Measured with 640-Hz low-pass filter
- 3) Output impedance is measured $\Delta V_{OUT}/\Delta I_{OUT}$ ($\Delta V_{OUT}=18\text{V} \dots 4.2\text{V}$) at $V_{DD} = 5\text{V}$, open-drain high state
- 4) For $V_{DD} = 5\text{ V}$, $R_L = 2.2\text{ k}\Omega$, $C_L = 4.7\text{ nF}$ (in package), at room temperature, not considering condenser tolerance or influence of external circuitry

Electrical, Thermal, and Magnetic Parameters

5) Depends on external R_L and C_L

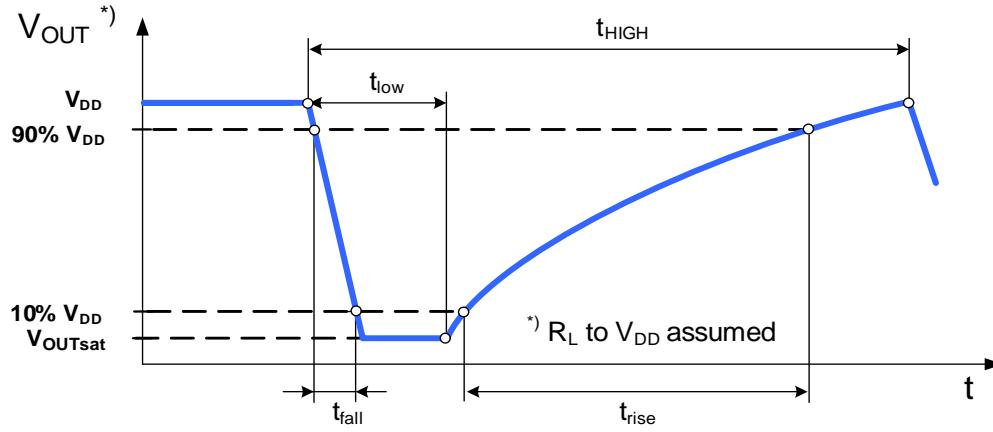

6) Range 100 mT, Gain 2.23, internal LP filter 244 Hz, $B = 0$ mT, $T = 25$ °C

Electrical, Thermal, and Magnetic Parameters

Calculation of the Junction Temperature

The internal power dissipation P_{TOT} of the sensor increases the chip junction temperature above the ambient temperature.

The power multiplied by the total thermal resistance R_{thJA} (Junction to Ambient) added to T_A leads to the final junction temperature. R_{thJA} is the sum of the addition of the two components, *Junction to Case* and *Case to Ambient*.

$$R_{thJA} = R_{thJC} + R_{thCA}$$

$$T_J = T_A + \Delta T$$

$$\Delta T = R_{thJA} \times P_{TOT} = R_{thJA} \times (V_{DD} \times I_{DD} + V_{OUT} \times I_{OUT}) \quad I_{DD}, I_{OUT} > 0, \text{ if direction is into IC}$$

Example (assuming no load on Vout):

- $V_{DD} = 5 \text{ V}$
- $I_{DD} = 8 \text{ mA}$
- $\Delta T = 190 \text{ [K/W]} \times (5 \text{ [V]} \times 0.008 \text{ [A]} + 0 \text{ [VA]}) = 7.6 \text{ K}$

For moulded sensors, the calculation with R_{thJC} is more adequate.

Magnetic Parameters

Table 5 **Magnetic Characteristics**

Parameter	Symbol	Limit Values			Unit	Notes
		min.	typ.	max.		
Sensitivity	$S^{1)}$	± 8.2	-	± 245	LSB ₁₂ /mT	Programmable ²⁾
Sensitivity drift	ΔS	-	± 80	± 150	ppm/ °C	³⁾ See Figure 4
Magnetic field range	MFR	± 50	$\pm 100^{4)}$	± 200	mT	Programmable ⁵⁾
Integral nonlinearity	INL	-	± 0.05	± 0.1	%MFR	⁶⁾⁸⁾
Magnetic offset	B_{OS}	-	-	± 400	μT	⁷⁾⁸⁾
Magnetic offset drift	ΔB_{OS}	-	± 1	± 5	$\mu\text{T} / ^\circ\text{C}$	Error band ⁸⁾
Magnetic hysteresis	B_{HYS}	-	-	10	μT	⁹⁾

1) Defined as $\Delta OUT / \Delta B$

2) Programmable in steps of 0.024%

3) For any 1st and 2nd order polynomial, coefficient within definition in Chapter 8. Valid for characterization at 0h

Electrical, Thermal, and Magnetic Parameters

- 4) This range is also used for temperature and offset pre-calibration of the IC
- 5) Depending on offset and gain settings, the output may already be saturated at lower fields
- 6) Gain setup is 1.0
- 7) In operating temperature range and over lifetime
- 8) Measured at ± 100 mT range
- 9) Measured in 100 mT range, Gain = 1, room temperature

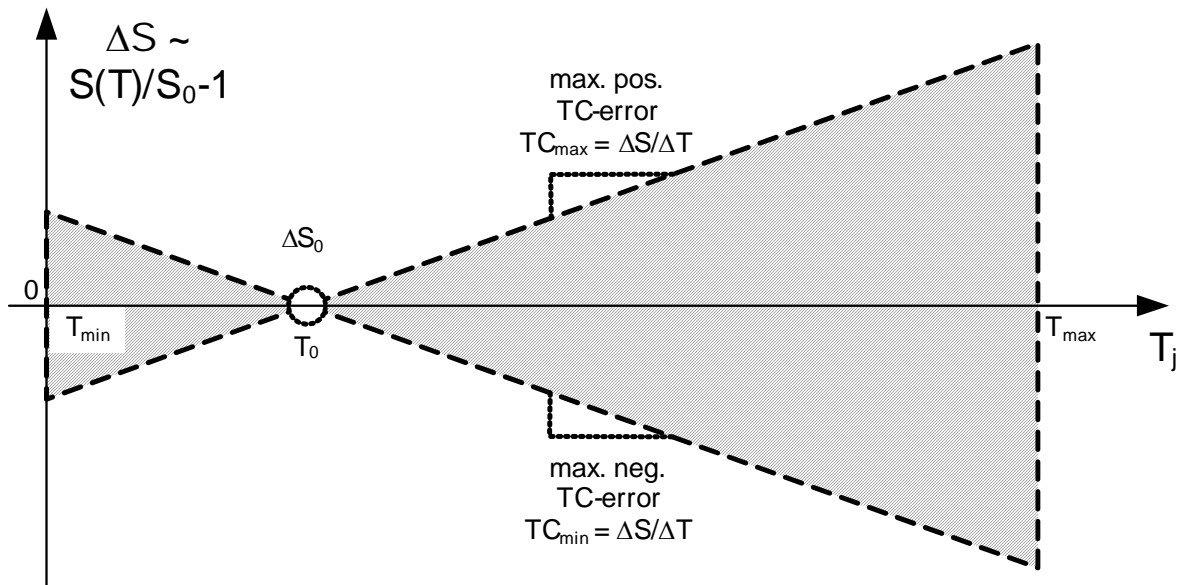

Figure 4 Sensitivity drift

6 Signal Processing

The signal flow diagram in [Figure 5](#) shows the signal path and data-processing algorithm.

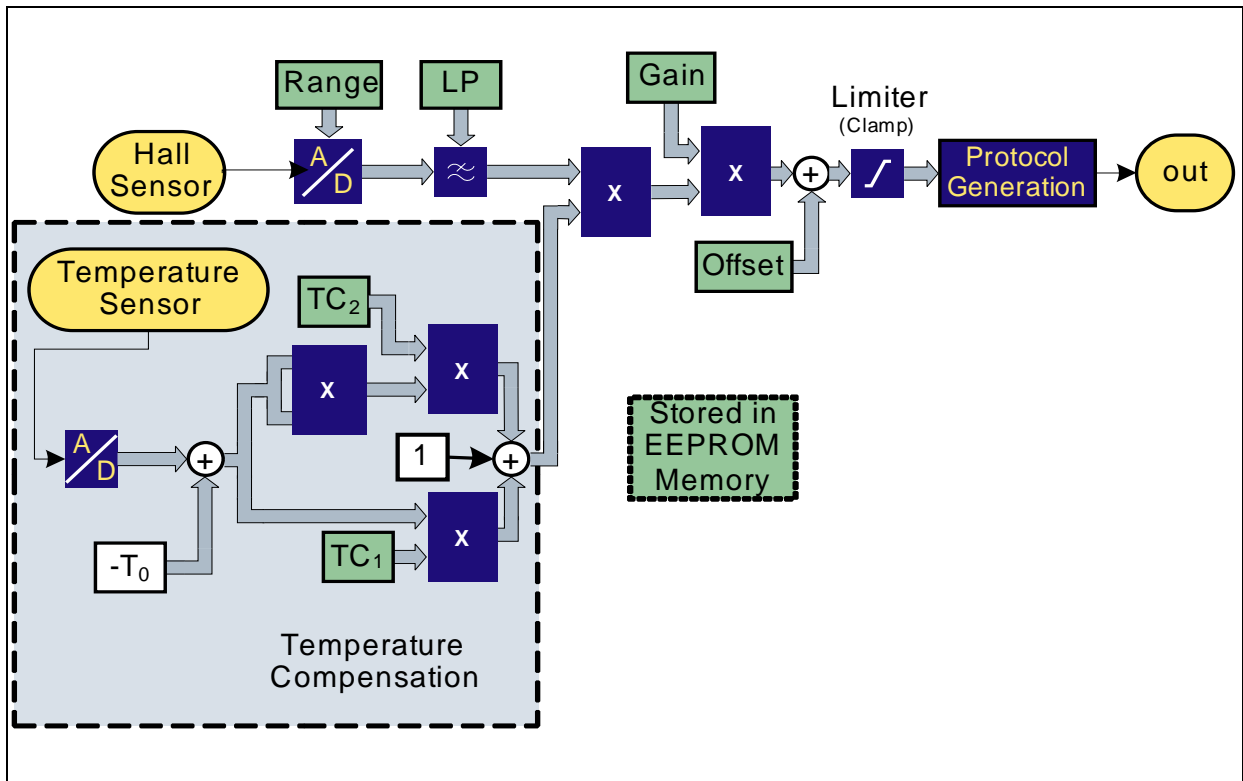

Figure 5 Signal Processing Flow

Magnetic Field Path

- The analog output signal of the chopped Hall-effect cell is converted to a digital signal in the continuous-time A/D converter. The range of the chopped A/D converter can be set in several steps (see [Table 6](#)). This gives a suitable level for the A/D converter
- After the A/D conversion, a digital low-pass filter reduces the bandwidth ([Table 10](#))
- A multiplier amplifies the value depending on the gain (see [Table 8](#)) and temperature compensation settings
- The offset value is added (see [Table 9](#))
- A limiter reduces the resulting signal to 16 bits (see [Chapter 11](#)) and feeds the Protocol Generation stage

Temperature Compensation

(Details are listed in [Chapter 8](#))

- The output signal of the temperature cell is also A/D converted

Signal Processing

- The temperature is normalized by subtraction of the reference temperature T_0 value (zero point of the quadratic function)
- The linear path is multiplied with the TC_1 value
- In the quadratic path, the temperature difference to T_0 is squared and multiplied with the TC_2 value
- Both path outputs are added together and multiplied with the Gain value from the EEPROM

6.1 Magnetic Field Ranges

The working range of the magnetic field defines the input range of the A/D converter. It is always symmetrical around the zero field point. Any two points in the magnetic field range can be selected to be the end points of the output value. The output value is represented within the range between the two points.

In the case of fields higher than the range values, the output signal may be distorted. The range must be set before the calibration of offset and gain.

Table 6 Range Setting

Range	Range in mT ¹⁾	Parameter R
Low	± 50	3
Mid	± 100	1 ²⁾
High	± 200	0

1) Ranges do not have a guaranteed absolute accuracy. The temperature pre-calibration is performed in the mid range (100 mT)

2) Setting $R = 2$ is not used, internally changed to $R = 1$

Table 7 Range

Parameter	Symbol	Limit Values		Unit	Notes
		min.	max.		
Register size	<i>R</i>	2		bit	

6.2 Gain Setting

The overall sensitivity is defined by the range and the gain setting. The output of the ADC is multiplied with the Gain value.

Table 8 Gain

Parameter	Symbol	Limit Values		Unit	Notes
		min.	max.		
Register size	<i>G</i>	15		bit	Unsigned integer value
Gain range	<i>Gain</i>	- 4.0	3.9998	-	1)2)
Gain quantization steps	$\Delta Gain$	244.14		ppm	Corresponds to 1/4096

1) For Gain values between - 0.5 and + 0.5, the numerical accuracy decreases
To obtain a flatter output curve, it is advisable to select a higher range setting

2) A gain value of +1.0 corresponds to typical 32 LSB₁₂/mT sensitivity (100 mT range, not guaranteed). It is crucial to do a final calibration of each IC within the application using the Gain/OUT_{OS} value

The Gain value can be calculated by:

$$Gain = \frac{(G - 16384)}{4096}$$

6.3 Offset Setting

The offset value corresponds to an output value with zero field at the sensor.

Table 9 Offset

Parameter	Symbol	Limit Values		Unit	Notes
		min.	max.		
Register size	<i>OS</i>	15		bit	Unsigned integer value
Offset range	<i>OUT_{OS}</i>	-16384	16383	LSB ₁₂	1)
Offset quantization steps	ΔOUT_{OS}	1		LSB ₁₂	

1) Infineon pre-calibrates the samples at zero field to 50% output value (100 mT range), but does not guarantee the value. Therefore it is crucial to do a final calibration of each IC within the application

The offset value can be calculated by:

$$OUT_{OS} = OS - 16384$$

6.4 DSP Input Low-Pass Filter

A digital low-pass filter is placed between the Hall A/D converter and the DSP, and can be used to reduce the noise level. The low-pass filter has a constant DC amplification of 0 dB (Gain of 1), which means that its setting has no influence on the internal Hall ADC value.

The bandwidth can be set to any of 8 values.

Table 10 Low Pass Filter Setting

<i>Note: Parameter LP</i>	Cutoff frequency in Hz (-3dB point) ¹⁾
0	80
1	240
2	440
3	640
4	860
5	1100
6	1390
7	off

¹⁾ As this is a digital filter running with an RC-based oscillator, the cutoff frequency may vary within $\pm 20\%$

Table 11 Low-Pass Filter

Parameter	Symbol	Limit Values		Unit	Notes
		min.	max.		
Register size	<i>LP</i>	3		bit	
Corner frequency variation	Δf	- 20	+ 20	%	

Note: In range 7 (filter off), the output noise increases.

Signal Processing

Figure 6 shows the filter characteristics as a magnitude plot (the highest setting is marked). The “off” position would be a flat 0 dB line. The update rate after the low-pass filter is 16 kHz.

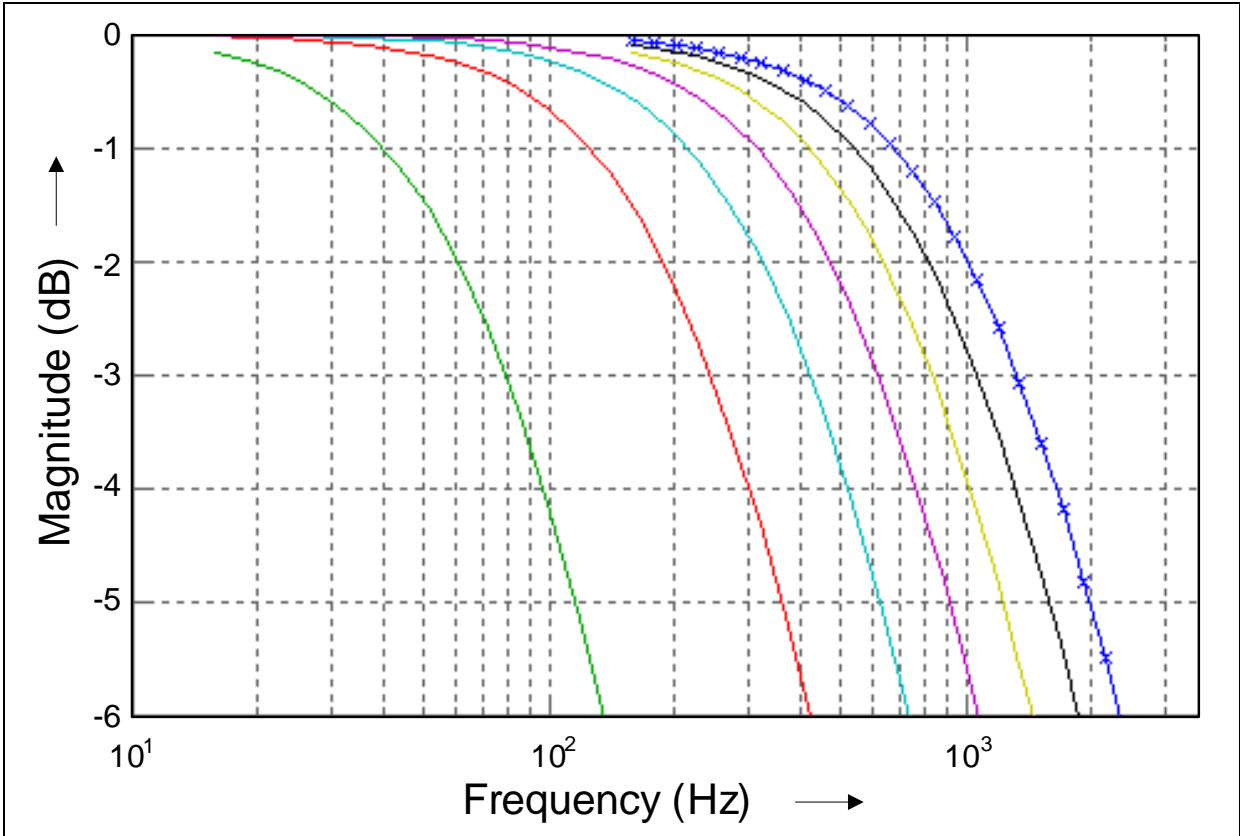

Figure 6 DSP Input Filter (Magnitude Plot)

6.5 Clamping

The clamping function is useful for separating the output range into an operating range and error ranges. If the magnetic field is exceeding the selected measurement range, the output value *OUT* is limited to the clamping values. Any value in the error range is interpreted as an error by the sensor counterpart.

Table 12 Clamping

Parameter	Symbol	Limit Values		Unit	Notes
		min.	max.		
Register size	<i>CL, CH</i>	2 x 7		bit	(0...127)
Clamping value low	<i>OUT_{CL}</i>	0	65024	LSB ₁₆	¹⁾
Clamping value high	<i>OUT_{CH}</i>	511	65535	LSB ₁₆	^{1) 2)}
Clamping quantization steps	ΔOUT_{Cx}	512		LSB ₁₆	³⁾

¹⁾ For CL = 0 and CH = 127, the clamping function is disabled

²⁾ $OUT_{CL} < OUT_{CH}$ mandatory

³⁾ Quantization starts for CL at 0 LSB₁₆ and for CH at 65535 LSB₁₆

The clamping values are calculated by:

Clamping value low (deactivated if CL=0):

$$OUT_{CL} = CL \cdot 32 \cdot 16$$

Clamping value high (deactivated if CH=127):

$$OUT_{CH} = (CH + 1) \cdot 32 \cdot 16 - 1$$

Signal Processing

Figure 7 shows an example in which the magnetic field range between B_{min} and B_{max} is mapped to output values between 10240 LSB_{16} and 55295 LSB_{16} .

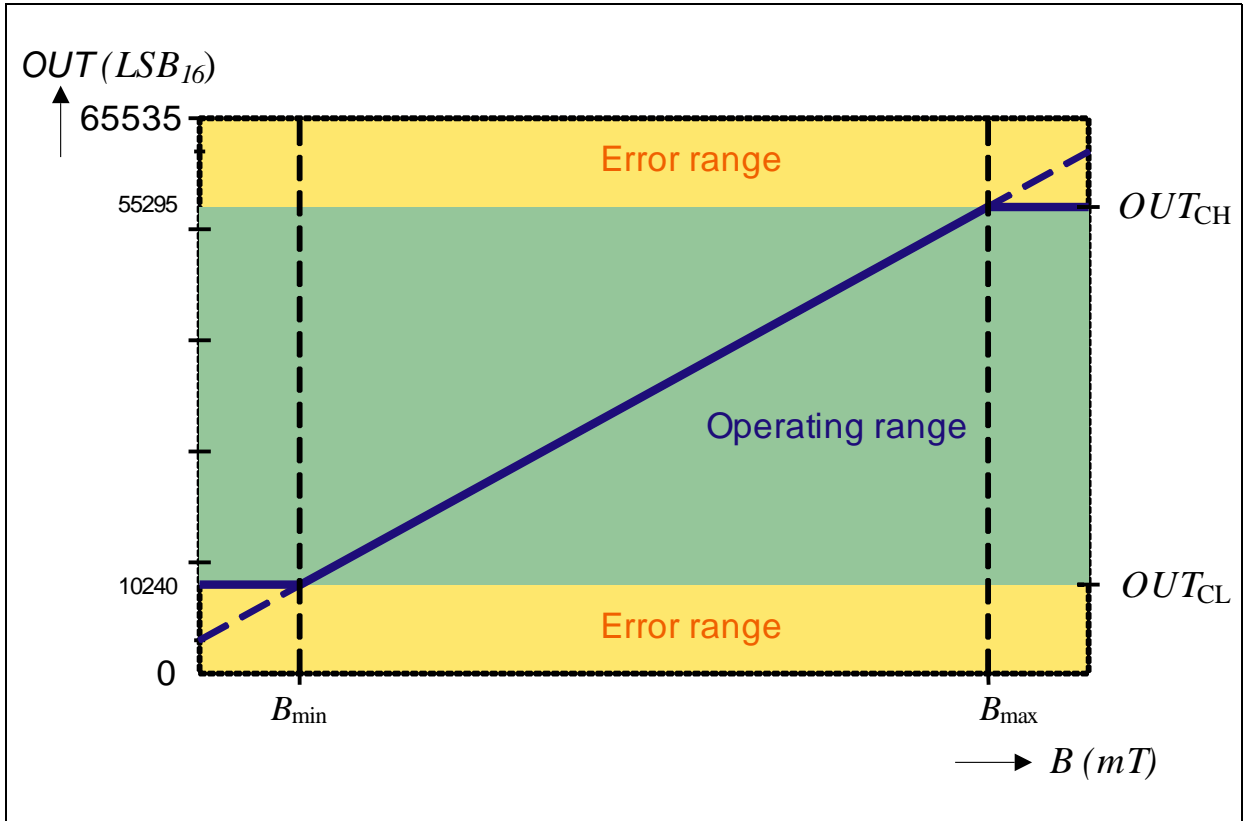

Figure 7 Clamping Example

Note: The clamping high value must be above the low value.

7 Error Detection

Different error cases can be detected by the On-Board Diagnostics (OBD) and reported to the microcontroller in the status nibble (see [Chapter 11](#)).

7.1 Voltages Outside the Operating Range

The output signals an error condition if V_{DD} crosses the overvoltage threshold level.

Table 13 Overvoltage

Parameter	Symbol	Limit Values			Unit	Notes
		min.	typ.	max.		
Overvoltage threshold	V_{DDov}	16.65	17.5	18.35	V	1)

1) Overvoltage bit activated in status nibble, output stays in "off" state (high ohmic)

7.2 EEPROM Error Correction

The parity method is able to correct a single bit in the EEPROM line. One other single bit error in another EEPROM line can also be detected, but not corrected. In an uncorrectable EEPROM failure, the open drain stage is disabled and kept in the off state permanently (high ohmic/sensor defect).

Temperature Compensation

8 Temperature Compensation

The magnetic field strength of a magnet depends on the temperature. This material constant is specific for the different magnet types. Therefore, the TLE4998S3C offers a second-order temperature compensation polynomial, by which the Hall signal output is multiplied in the DSP. There are three parameters for the compensation:

- Reference temperature T_0
- A linear part (1st order) TC_1
- A quadratic part (2nd order) TC_2

The following formula describes the sensitivity dependent on the temperature in relation to the sensitivity at the reference temperature T_0 :

$$S_{TC}(T) = 1 + TC_1 \times (T - T_0) + TC_2 \times (T - T_0)^2$$

For more information, please refer to the signal processing flow in [Figure 5](#).

The full temperature compensation of the complete system is done in two steps:

1. Pre-calibration in the Infineon final test

The parameters TC_1 , TC_2 , T_0 are set to maximally flat temperature characteristics with respect to the Hall probe and internal analog processing parts.

2. Overall system calibration

The typical coefficients TC_1 , TC_2 , T_0 of the magnetic circuitry are programmed. This can be done deterministically, as the algorithm of the DSP is fully reproducible. The final setting of the TC_1 , TC_2 , T_0 values depend on the pre-calibrated values.

Table 14 Temperature Compensation

Parameter	Symbol	Limit Values		Unit	Notes
		min.	max.		
Register size TC_1	TL	-	9	bit	Unsigned integer values
1 st order coefficient TC_1	TC_1	-1000	2500	ppm/ °C	1)
Quantization steps of TC_1	qTC_1	15.26		ppm/ °C	
Register size TC_2	TQ	-	8	bit	Unsigned integer values
2 nd order coefficient TC_2	TC_2	- 4	4	ppm/ °C ²	2)
Quantization steps of TC_2	qTC_2	0.119		ppm/ °C ²	
Reference temp.	T_0	- 48	64	°C	
Quantization steps of T_0	qT_0	1		°C	3)

1) Relative range to Infineon TC_1 temperature pre-calibration, the maximum adjustable range is limited by the register-size and depends on specific pre-calibrated TL setting, full adjustable range: -2441 to +5355 ppm/°C

2) Relative range to Infineon TC_2 temperature pre-calibration, the maximum adjustable range is limited by the register-size and depends on specific pre-calibrated TQ setting, full adjustable range: -15 to +15 ppm/°C²

³⁾ Handled by algorithm only (see Application Note)

8.1 Parameter Calculation

The parameters TC_1 and TC_2 may be calculated by:

$$TC_1 = \frac{TL - 160}{65536} \times 1000000$$

$$TC_2 = \frac{TQ - 128}{8388608} \times 1000000$$

Now the digital output for a given field B_{IN} at a specific temperature can be calculated by:

$$OUT = 2 \cdot \left(\frac{B_{IN}}{B_{FSR}} \times S_{TC} \times S_{TCHall} \times S_0 \times 4096 \right) + OUT_{OS}$$

B_{FSR} is the full-range magnetic field. It is dependent on the range setting (e.g 100 mT).

S_0 is the nominal sensitivity of the Hall probe times the Gain factor set in the EEPROM.

S_{TC} is the temperature-dependent sensitivity factor calculated by the DSP.

S_{TCHall} is the temperature behavior of the Hall probe.

The pre-calibration at Infineon is performed such that the following condition is met:

$$S_{TC}(T_J - T_0) \times S_{TCHall}(T_J) \approx 1$$

Within the application, an additional factor $B_{IN}(T) / B_{IN}(T_0)$ is given due to the magnetic system. S_{TC} then needs to be modified to S_{TCnew} so that the following condition is satisfied:

$$\frac{B_{IN}(T)}{B_{IN}(T_0)} \times S_{TCnew}(T) \times S_{TCHall}(T) \approx S_{TC}(T) \times S_{TCHall}(T) \approx 1$$

Therefore, the new sensitivity parameters S_{TCnew} can be calculated from the pre-calibrated setup S_{TC} using the relationship:

$$\frac{B_{IN}(T)}{B_{IN}(T_0)} \times S_{TCnew}(T) \approx S_{TC}(T)$$

9 Calibration

For the calibration of the sensor, a special hardware interface to a PC is required. All calibration and setting bits can be temporarily written into a Random Access Memory (RAM). This allows the EEPROM to remain untouched during the entire calibration process, since the number of the EEPROM programming cycles is limited. Therefore, this temporary setup (using the RAM only) does not stress the EEPROM.

The digital signal processing is completely deterministic. This allows a two-point calibration to be performed in one step without iterations. After measuring the Hall output signal for the two end points, the signal processing parameters Gain and Offset can be calculated.

Table 15 Calibration Characteristics

Parameter	Symbol	Limit Values		Unit	Notes
		min.	max.		
Ambient temperature at calibration	T_{CAL}	10	30	°C	
2 point Calibration accuracy ¹⁾	ΔOUT_{CAL1}	-8	8	LSB ₁₂	Position 1
	ΔOUT_{CAL2}	-8	8	LSB ₁₂	Position 2

¹⁾ Corresponds to $\pm 0.2\%$ accuracy in each position

9.1 Calibration Data Memory

When the MEMLOCK bits are programmed (two redundant bits), the memory content is frozen and may no longer be changed. Furthermore, the programming interface is locked out and the chip remains in application mode only, preventing accidental programming due to environmental influences.

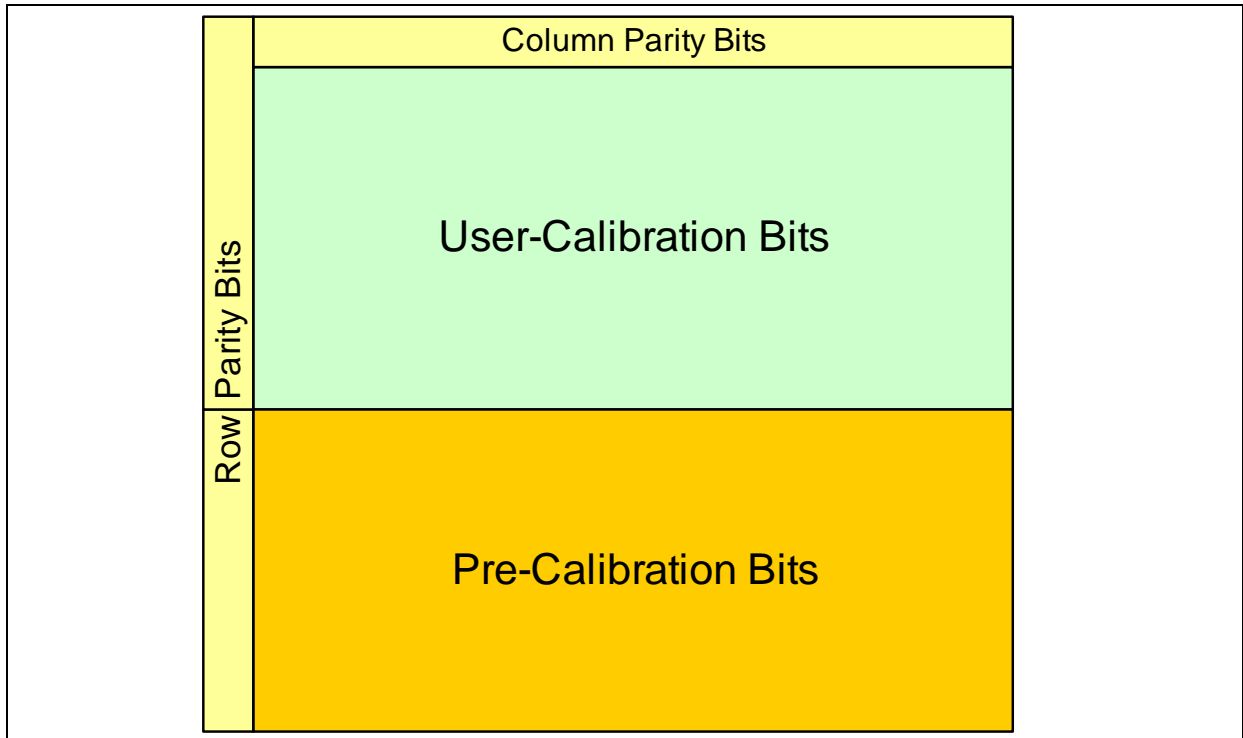

Figure 8 EEPROM Map

A matrix parity architecture allows automatic correction of any single-bit error. Each row is protected by a row parity bit. The sum of bits set (including this bit) must be an odd number (ODD PARITY). Each column is additionally protected by a column parity bit. Each bit in the even positions (0, 2, etc.) of all lines must sum up to an even number (EVEN PARITY), and each bit in the odd positions (1, 3, etc.) must have an odd sum (ODD PARITY). The parity column must have an even sum (EVEN PARITY).

This system of different parity calculations also protects against many block errors (such as erasing a full line or even the whole EEPROM).

When modifying the application bits (such as Gain, Offset, TC, etc.), the parity bits must be updated. As for the column bits, the pre-calibration area must be read out and considered for correct parity generation as well.

Note: A specific programming algorithm must be followed to ensure data retention. A detailed separate programming specification is available on request.

Table 16 Programming Characteristics

Parameter	Symbol	Limit Values		Unit	Notes
		min.	max.		
Number of EEPROM programming cycles	N_{PRG}	-	10	Cycles ¹⁾	Programming allowed only at start of lifetime
Ambient temperature at programming	T_{PRG}	10	30	°C	
Programming time	t_{PRG}	100	-	ms	For complete memory ²⁾
Calibration memory	-	150		Bit	All active EEPROM bits
Error Correction	-	26		Bit	All parity EEPROM bits

1) 1 cycle is the simultaneous change of ≥ 1 bit

2) Depending on clock frequency at V_{DD} , write pulse 10 ms $\pm 1\%$, erase pulse 80 ms $\pm 1\%$

9.2 Programming Interface

The VDD pin and the OUT pin are used as a two-wire interface to transmit the EEPROM data to and from the sensor.

This allows:

- Communication with high data reliability, parity protected
- The bus-type connection of several sensors and separate programming via the OUT pin

9.3 Data Transfer Protocol

The data transfer protocol is described in a separate document (User Programming Description), available on request.

9.4 Programming of Sensors with Common Supply Lines

In many automotive applications, two sensors are used to measure the same parameter. This redundancy makes it possible to continue operation in an emergency mode. If both sensors use the same power supply lines, they can be programmed together in parallel.

10 Application Circuit

Figure 9 shows the connection of multiple sensors to a microcontroller.

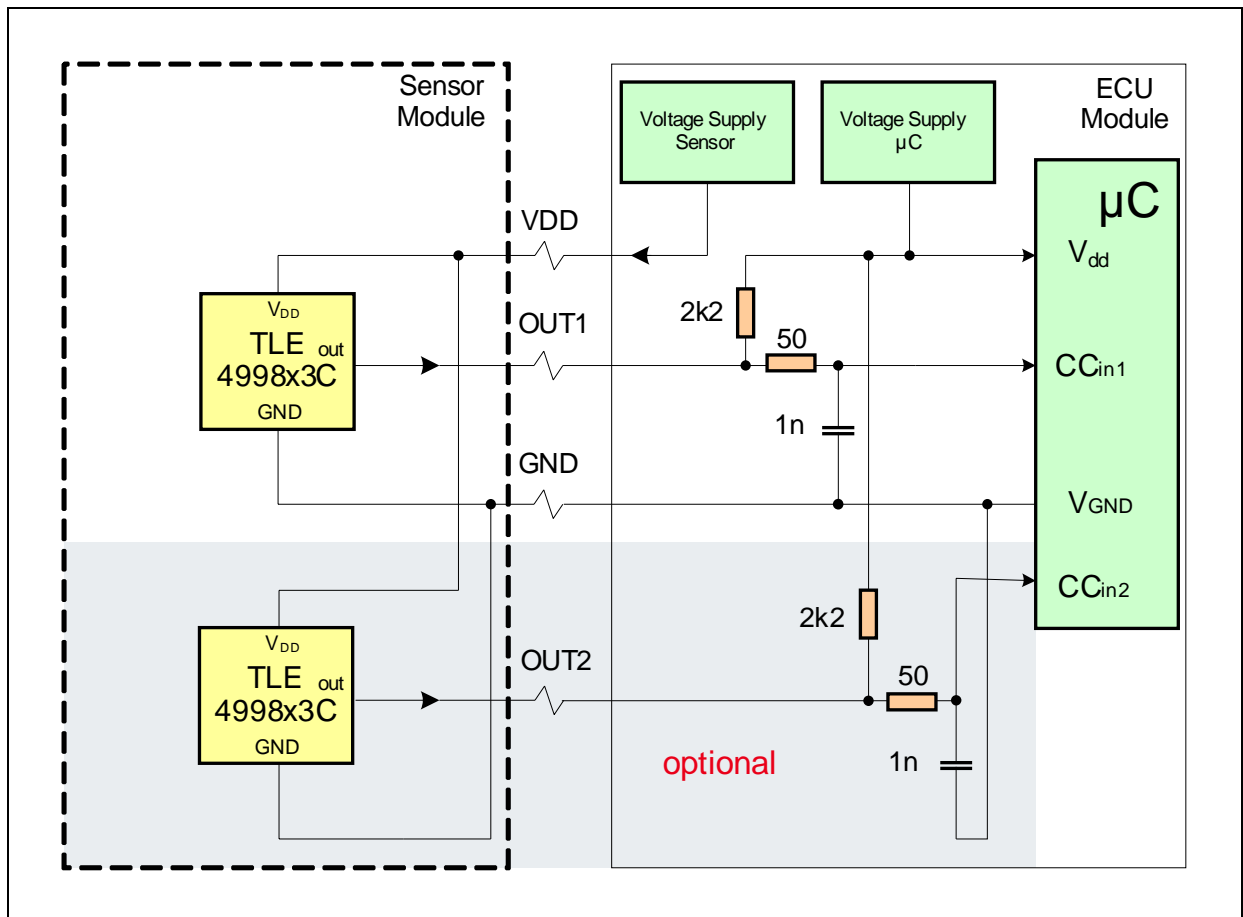

Figure 9 Application Circuit

Note: For calibration and programming, the interface has to be connected directly to the OUT pin.

The application circuit shown should be regarded as an example only. It will need to be adapted to meet the requirements of other specific applications.

11 PG-SSO-3-92 Package Outlines

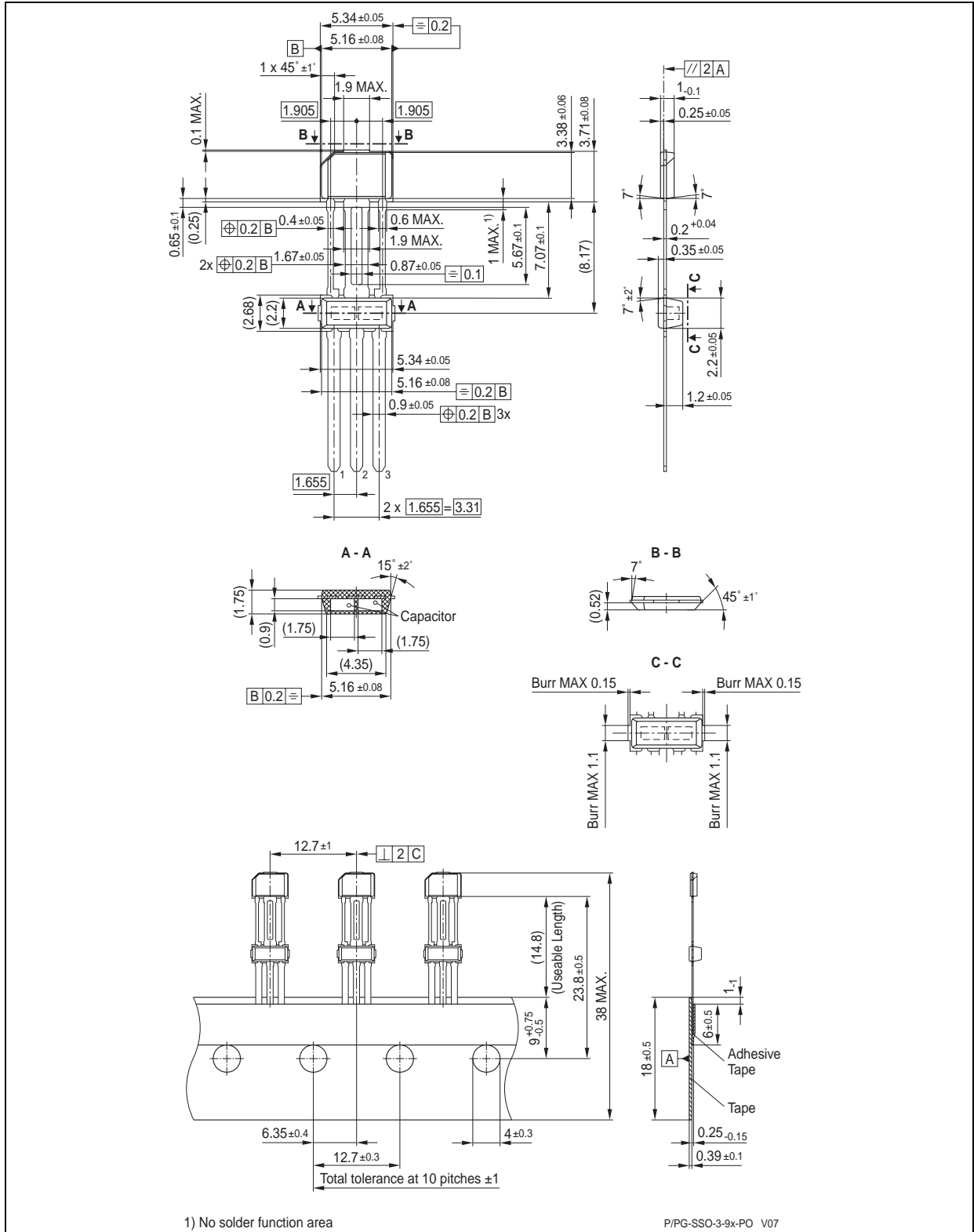

Figure 10 PG-SSO-3-92 (Plastic Green Single Small Outline Package)

SENT Output Definition (SAE J2716)

12 SENT Output Definition (SAE J2716)

The sensor supports a basic version of the Single Edge Nibble Transmission (SENT) protocol defined by SAE. The main difference between the standard version and its implementation in the TLE4998 is the usage of an open drain instead of a push-pull output.

12.1 Basic SENT Protocol Definition

The single edge is defined by a 3 unit time (UT) low pulse on the output, followed by the high time defined in the protocol (nominal values, may vary by tolerance of internal RC oscillator, not including analog delay of the open drain output and influence by external circuitry, unit time programming see [Section 12.2](#)). All values are multiples of a unit time frame concept. A transfer consists of the following parts:

- A synchronization period of 56 UT (in parallel, a new sample is calculated)
- A status nibble of 12-27 UT
- Three data nibbles of 12-27 UT (data packet 1 with a length of 36-81 UT)
- Three data nibbles of 12-27 UT (data packet 2 with a length of 36-81 UT)
- A CRC nibble of 12-27 UT

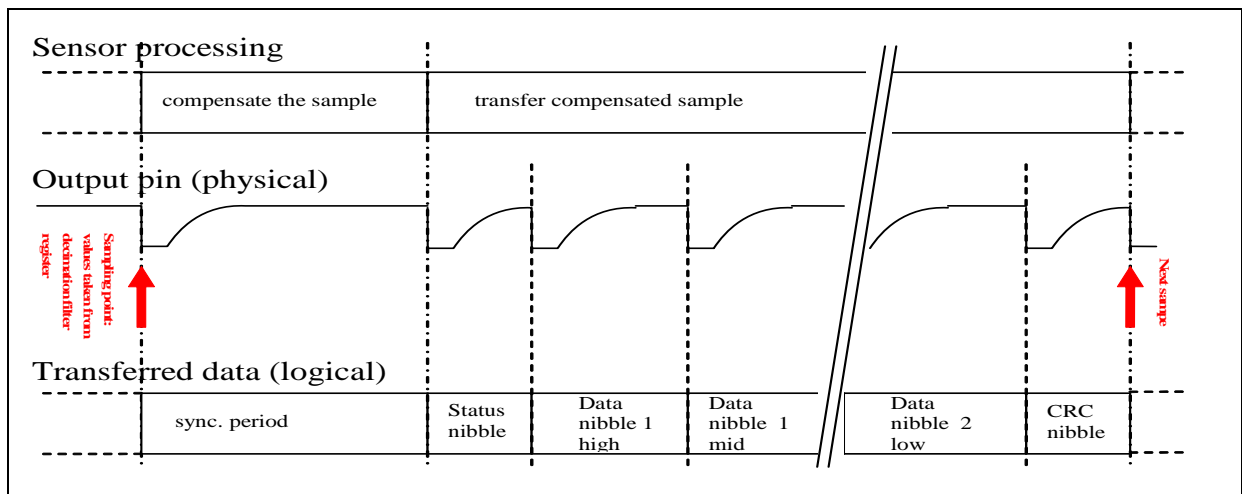

Figure 11 SENT Frame

The CRC checksum includes the status nibble and the data nibbles and can be used to check the validity of the decoded data. The sensor is available for the next sample 90µs after the falling edge of the end pulse. This leads to a minimum transfer time of 152 UT, and a maximum transfer time of 272 UT per sample.

SENT Output Definition (SAE J2716)

It is important to know that the sampling time (when values are taken for temperature compensation) here is always defined as the beginning of the synchronization period; during this period, the resulting data is always calculated from scratch.

As only one Hall value needs to be transferred within one sequence, the second data package is divided into two parts (see [Table 19](#)):

- First, the remaining 4 LSBs of the Hall signals are transferred in the first data nibble. This means the receiver may use the whole 16-bit data available in the sensor when reading and using all 4 nibbles transferred.
- Second, the temperature is transferred as an 8-bit value. The value is transferred in unsigned integer format and corresponds to -55°C to 200°C. For example, transferring the value 55 corresponds to 0°C. The temperature is additional information and although it is not calibrated, may be used for a plausibility check, for example.

Table 17 Mapping of Temperature Value

Junction Temperature	Typ. Decimal Value from Sensor	Note
- 55°C	0	Theoretical lower limit ¹⁾
0°C	55	
25°C	80	
200°C	255	Theoretical upper limit ¹⁾

¹⁾ Theoretical range of temperature values, not operating temperature range

The status nibble allows to check internal states and conditions of the sensor.

- The first two bits of the status nibble contain the selected magnetic range of the sensor and therefore allow the received data to be interpreted easily.
- The third bit is set to “1” for the first transmission after the sensor returns from an overvoltage operation with disabled open drain stage to regular operation (see [Chapter 7.1](#)).
- The fourth bit is switched to “1” for the first data package transferred after a reset. This allows the detection of low-voltage situations or EMC problems of the sensor.

12.2 Unit Time Setup

The basic SENT protocol unit time granularity is defined as 3 μs. Every timing is a multiple of this basic time unit. To achieve more flexibility, trimming of the unit time can be used to:

- Allow a calibration trim within a timing error of less than 20% clock error (as given in SAE standard)
- Allow a modification of the unit time for small speed adjustments

SENT Output Definition (SAE J2716)

This enables a setup of different unit times, even if the internal RC oscillator varies by $\pm 20\%$. Of course, timing values that are too low could clash with timing requirements of the application and should therefore be avoided, but in principle it is possible to adjust the timer unit for a more precise protocol timing. The output characteristic depends on the external load, the wiring, as well on the pull-up voltage and the temperature. All these parameters have considerable influence to find the proper unit time setup.

Table 18 Predivider Setting

Parameter	Symbol	Limit Values		Unit	Notes
		min.	max.		
Register size	<i>Prediv</i>	4		bit	Predivider ¹⁾
Unit time	t_{UNIT}	2.0	4.0	μs	$Clk_{UNIT}=8MHz^{2)}$

1) Useable predivider range is decimal 7 to 15. Prediv < 7 is internally kept at 7. Prediv default is decimal = 11 for 3 μs nominal unit time

2) RC oscillator frequency variation +/- 20%

The nominal unit time is calculated by:

$$t_{UNIT} = (Prediv \times 2 + 2) / Clk_{UNIT}$$

$$Clk_{UNIT} = 8MHz \pm 20\%$$

SENT Output Definition (SAE J2716)

Table 19 Content of a SENT Data Frame (8 Nibbles)

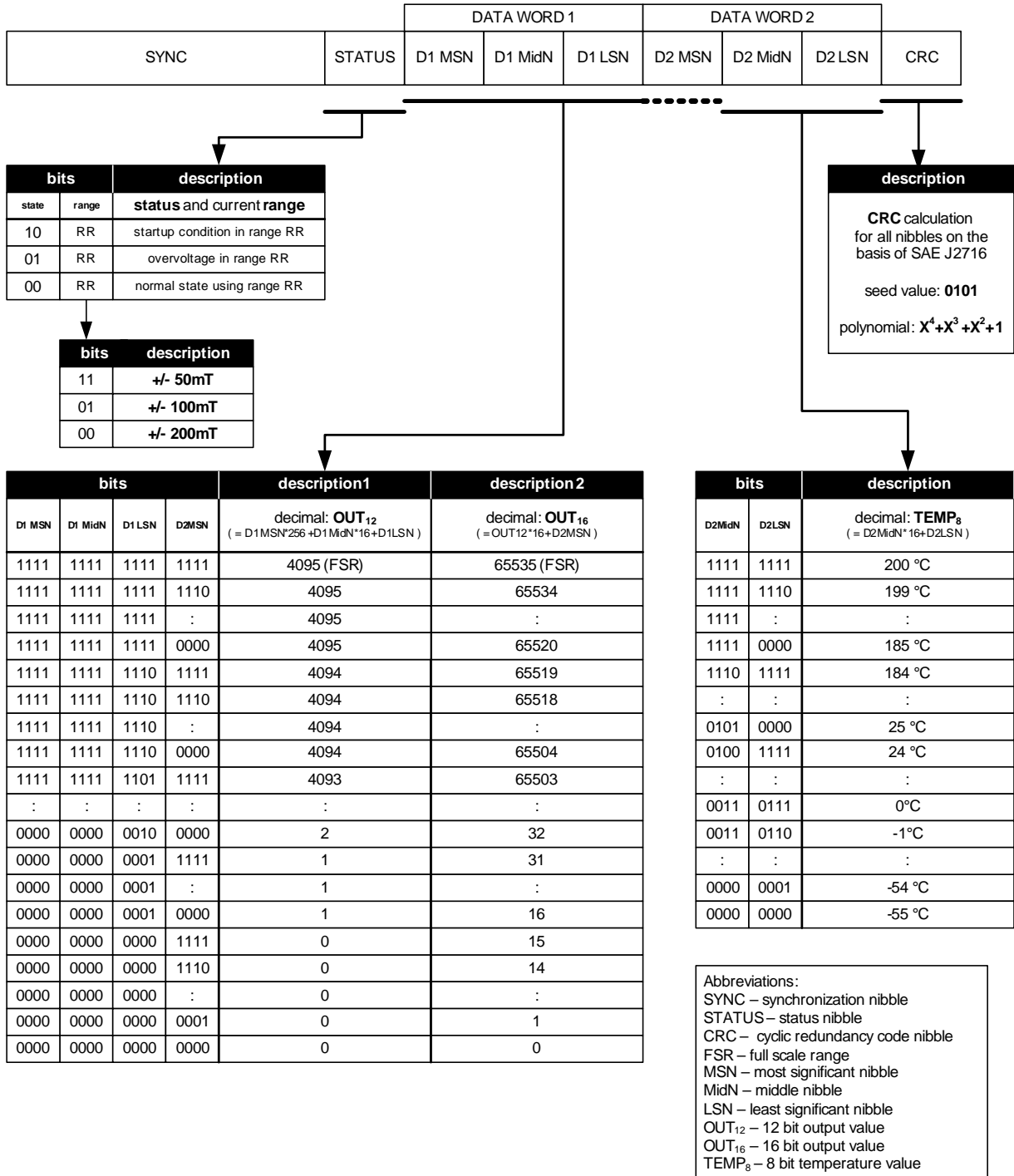

SENT Output Definition (SAE J2716)

12.3 Checksum Nibble Details

The Checksum nibble is a 4-bit CRC of the data nibbles including the status nibble. The CRC is calculated using a polynomial $x^4 + x^3 + x^2 + 1$ with a seed value of 0101.

In the TLE4998S3C it is implemented as a series of XOR and shift operations as shown in the following flowchart:

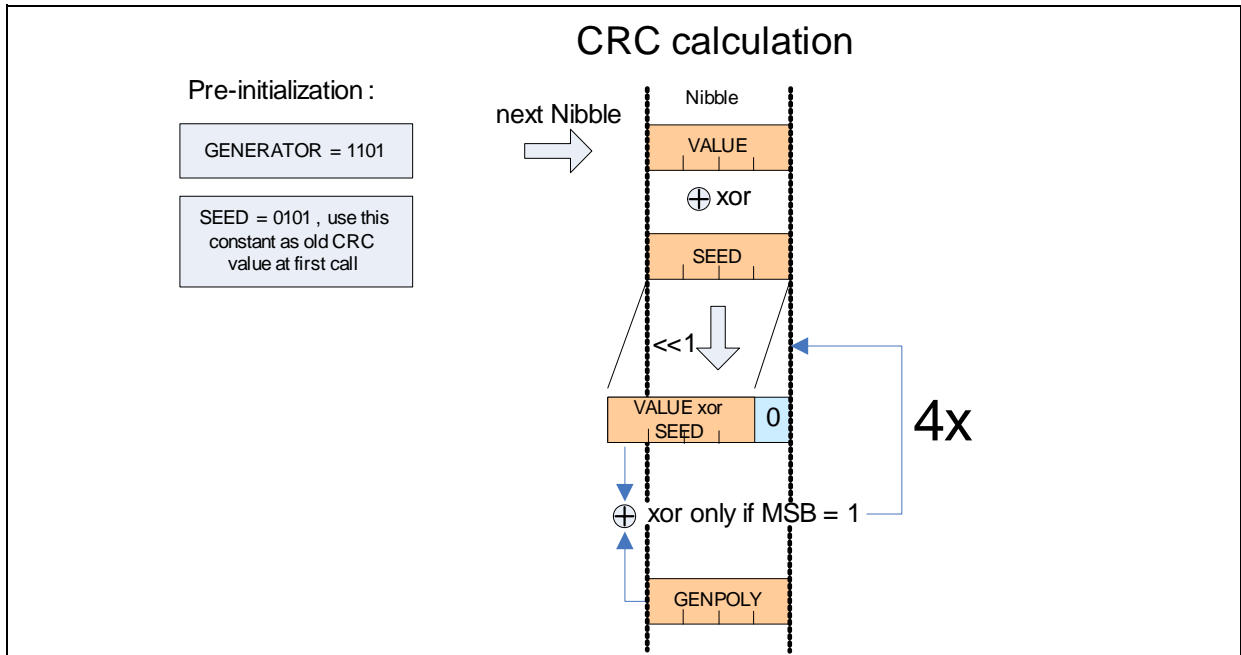

Figure 12 CRC Calculation

A microcontroller implementation may use an XOR command plus a small 4-bit lookup table to calculate the CRC for each nibble.

```

// Fast way for any μC with low memory and compute capabilities
char Data[8] = {...}; // contains the input data (status nibble, 6 data nibble, CRC)
// required variables and LUT
char CheckSum, i;
char CrcLookup[16] = {0, 13, 7, 10, 14, 3, 9, 4, 1, 12, 6, 11, 15, 2, 8, 5};
CheckSum= 5; // initialize checksum with seed "0101"
for (i=0; i<7; i++) {
    CheckSum = CheckSum ^ Data[i];
    CheckSum = CrcLookup[CheckSum];
}
; // finally check if Data [7] is equal to CheckSum
    
```

Figure 13 Example Code for CRC Generation

www.infineon.com

Published by Infineon Technologies AG