

# TLE7250

High Speed CAN-Transceiver

TLE7250LE  
TLE7250SJ

## Data Sheet

Rev. 1.0, 2015-08-12

## Table of Contents

|           |                                                       |    |
|-----------|-------------------------------------------------------|----|
|           | <b>Table of Contents</b> .....                        | 2  |
| <b>1</b>  | <b>Overview</b> .....                                 | 3  |
| <b>2</b>  | <b>Block Diagram</b> .....                            | 5  |
| <b>3</b>  | <b>Pin Configuration</b> .....                        | 6  |
| 3.1       | Pin Assignment .....                                  | 6  |
| 3.2       | Pin Definitions .....                                 | 6  |
| <b>4</b>  | <b>Functional Description</b> .....                   | 8  |
| 4.1       | High Speed CAN Physical Layer .....                   | 8  |
| 4.2       | Modes of Operation .....                              | 10 |
| 4.2.1     | Normal-operating Mode .....                           | 10 |
| 4.2.2     | Power-save Mode .....                                 | 10 |
| 4.2.3     | Receive-only Mode .....                               | 10 |
| 4.3       | Power-up and Undervoltage Condition .....             | 11 |
| 4.3.1     | Power-down State .....                                | 12 |
| 4.3.2     | Power-up .....                                        | 12 |
| 4.3.3     | Undervoltage on the Transmitter Supply $V_{CC}$ ..... | 13 |
| <b>5</b>  | <b>Fail Safe Functions</b> .....                      | 14 |
| 5.1       | Short Circuit Protection .....                        | 14 |
| 5.2       | Unconnected Logic Pins .....                          | 14 |
| 5.3       | TxD Time-out Function .....                           | 14 |
| 5.4       | Overtemperature Protection .....                      | 15 |
| 5.5       | Delay Time for Mode Change .....                      | 15 |
| <b>6</b>  | <b>General Product Characteristics</b> .....          | 16 |
| 6.1       | Absolute Maximum Ratings .....                        | 16 |
| 6.2       | Functional Range .....                                | 17 |
| 6.3       | Thermal Resistance .....                              | 17 |
| <b>7</b>  | <b>Electrical Characteristics</b> .....               | 18 |
| 7.1       | Functional Device Characteristics .....               | 18 |
| 7.2       | Diagrams .....                                        | 23 |
| <b>8</b>  | <b>Application Information</b> .....                  | 25 |
| 8.1       | ESD Robustness according to IEC61000-4-2 .....        | 25 |
| 8.2       | Application Example .....                             | 26 |
| 8.3       | Examples for Mode Changes .....                       | 27 |
| 8.3.1     | Mode Change while the TxD Signal is “low” .....       | 28 |
| 8.3.2     | Mode Change while the Bus Signal is “dominant” .....  | 28 |
| 8.4       | Further Application Information .....                 | 31 |
| <b>9</b>  | <b>Package Outline</b> .....                          | 32 |
| <b>10</b> | <b>Revision History</b> .....                         | 33 |



## 1 Overview

### Features

- Fully compatible to ISO 11898-2
- Wide common mode range for electromagnetic immunity (EMI)
- Very low electromagnetic emission (EME)
- Excellent ESD robustness
- Guaranteed loop delay symmetry to support CAN FD data frames up to 2 MBit/s
- Extended supply range on  $V_{CC}$  supply
- CAN short circuit proof to ground, battery and  $V_{CC}$
- TxD time-out function
- Low CAN bus leakage current in power-down state
- Overtemperature protection
- Protected against automotive transients
- Receive-only mode and power-save mode
- Green Product (RoHS compliant)
- Two package variants: PG-DSO-8 and PG-TSON-8
- AEC Qualified

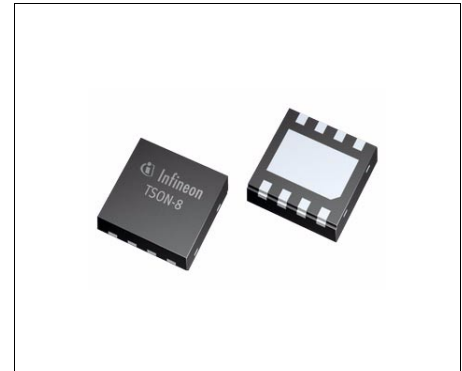

**PG-TSON-8**

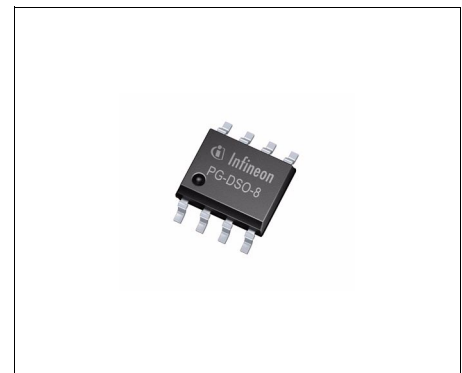

**PG-DSO-8**

### Description

The TLE7250 is a transceiver designed for HS CAN networks in automotive and industrial applications. As an interface between the physical bus layer and the CAN protocol controller, the TLE7250 drives the signals to the bus and protects the microcontroller against interferences generated within the network. Based on the high symmetry of the CANH and CANL signals, the TLE7250 provides a very low level of electromagnetic emission (EME) within a wide frequency range.

The TLE7250 is available in a small, leadless PG-TSON-8 package and in a PG-DSO-8 package. Both packages are RoHS compliant and halogen free. Additionally the PG-TSON-8 package supports the solder joint requirements for automated optical inspection (AOI). The TLE7250LE and the TLE7250SJ are fulfilling or exceeding the requirements of the ISO11898-2.

The TLE7250 provides a receive-only mode and a power-save mode. It is designed to fulfill the enhanced physical layer requirements for CAN FD and supports data rates up to 2 MBit/s.

On the basis of a very low leakage current on the HS CAN bus interface the TLE7250 provides an excellent passive behavior in power-down state. These and other features make the TLE7250 exceptionally suitable for mixed supply HS CAN networks.

Based on the Infineon Smart Power Technology SPT, the TLE7250 provides excellent ESD immunity together with

| Type      | Package   | Marking |
|-----------|-----------|---------|
| TLE7250LE | PG-TSON-8 | 7250    |
| TLE7250SJ | PG-DSO-8  | 7250    |

a very high electromagnetic immunity (EMI). The TLE7250 and the Infineon SPT technology are AEC qualified and tailored to withstand the harsh conditions of the automotive environment.

Three different operating modes, additional fail-safe features like a TxD time-out and the optimized output slew rates on the CANH and CANL signals, make the TLE7250 the ideal choice for large HS CAN networks with high data transmission rates.



### 3 Pin Configuration

#### 3.1 Pin Assignment

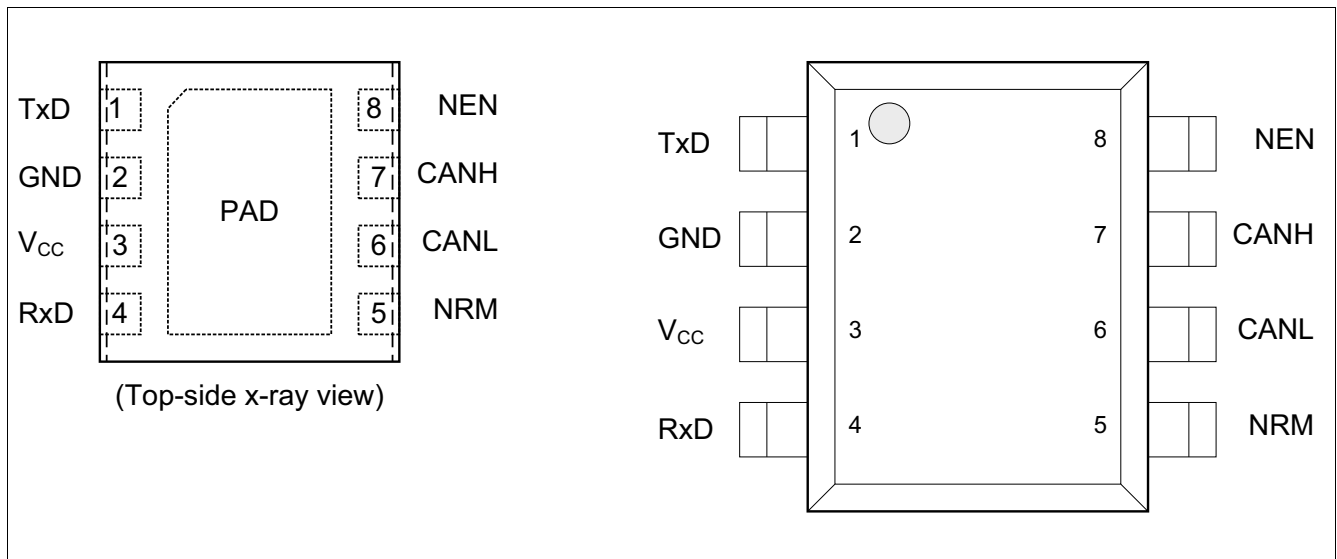

Figure 2 Pin configuration

#### 3.2 Pin Definitions

Table 1 Pin definitions and functions

| Pin No. | Symbol   | Function                                                                                                                                             |
|---------|----------|------------------------------------------------------------------------------------------------------------------------------------------------------|
| 1       | TxD      | <b>Transmit Data Input;</b><br>internal pull-up to $V_{CC}$ , “low” for “dominant” state.                                                            |
| 2       | GND      | <b>Ground</b>                                                                                                                                        |
| 3       | $V_{CC}$ | <b>Transmitter Supply Voltage;</b><br>100 nF decoupling capacitor to GND required.                                                                   |
| 4       | RxD      | <b>Receive Data Output;</b><br>“low” in “dominant” state.                                                                                            |
| 5       | NRM      | <b>Not Receive-Only Mode Input;</b><br>control input for selecting receive-only mode,<br>internal pull-up to $V_{CC}$ , “low” for receive-only mode. |
| 6       | CANL     | <b>CAN Bus Low Level I/O;</b><br>“low” in “dominant” state.                                                                                          |
| 7       | CANH     | <b>CAN Bus High Level I/O;</b><br>“high” in “dominant” state.                                                                                        |

**Table 1** Pin definitions and functions (cont'd)

| Pin No. | Symbol | Function                                                                                                            |
|---------|--------|---------------------------------------------------------------------------------------------------------------------|
| 8       | NEN    | <b>Not Enable Input;</b><br>internal pull-up to $V_{CC}$ ,<br>“low” for normal-operating mode or receive-only mode. |
| PAD     | –      | Connect to PCB heat sink area.<br>Do not connect to other potential than GND.                                       |

## 4 Functional Description

HS CAN is a serial bus system that connects microcontrollers, sensors and actuators for real-time control applications. The use of the Controller Area Network (abbreviated CAN) within road vehicles is described by the international standard ISO 11898. According to the 7-layer OSI reference model the physical layer of a HS CAN bus system specifies the data transmission from one CAN node to all other available CAN nodes within the network. The physical layer specification of a CAN bus system includes all electrical and mechanical specifications of a CAN network. The CAN transceiver is part of the physical layer specification. Several different physical layer standards of CAN networks have been developed in recent years. The TLE7250 is a High Speed CAN transceiver without a wake-up function and defined by the international standard ISO11898-2.

### 4.1 High Speed CAN Physical Layer

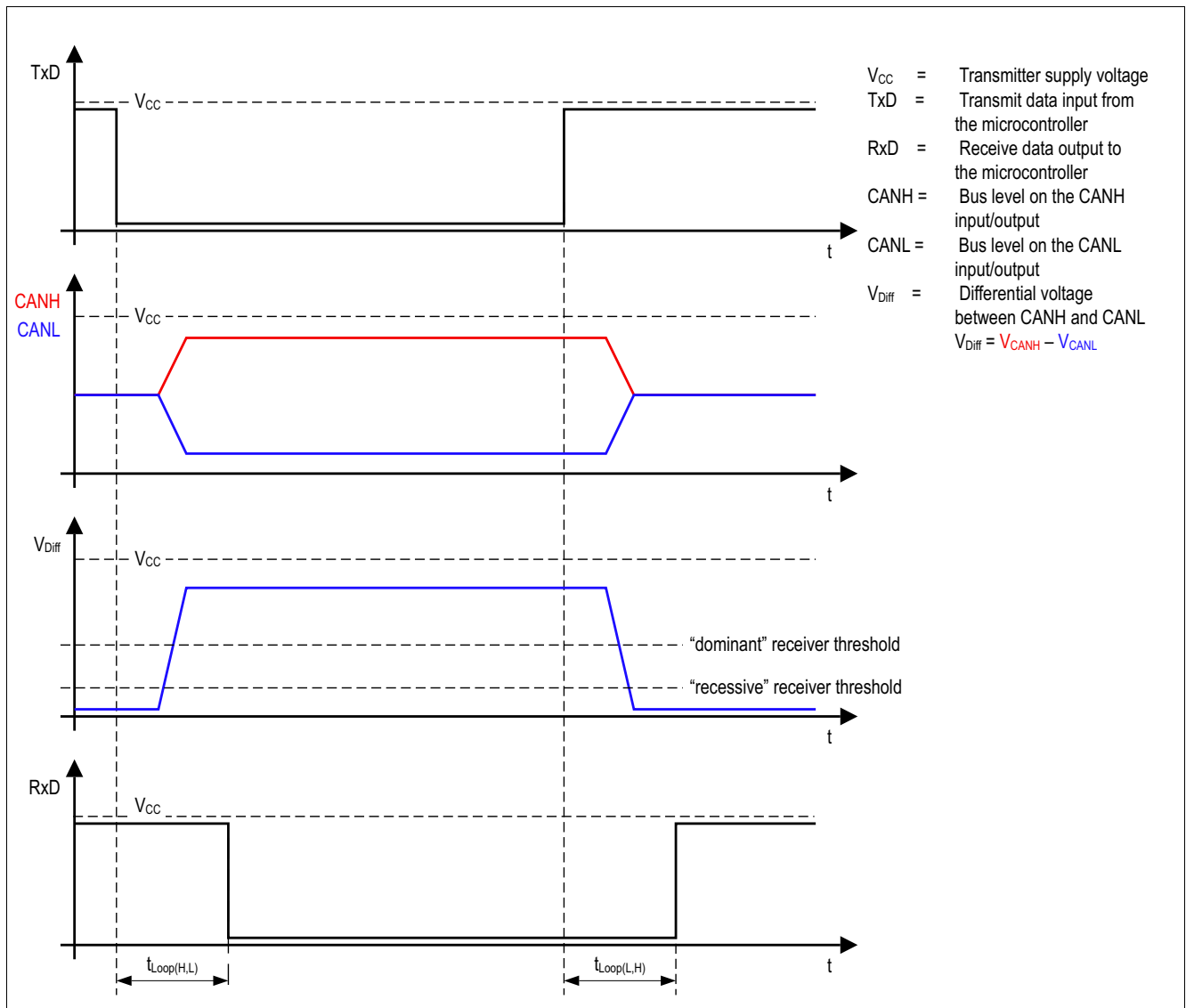

Figure 3 High speed CAN bus signals and logic signals

The TLE7250 is a High-Speed CAN transceiver, operating as an interface between the CAN controller and the physical bus medium. A HS CAN network is a two wire, differential network which allows data transmission rates for CAN FD frames up to 2 MBit/s. Characteristic for HS CAN networks are the two signal states on the HS CAN bus: “dominant” and “recessive” (see [Figure 3](#)).

$V_{CC}$  and GND are the supply pins for the TLE7250. The pins CANH and CANL are the interface to the HS CAN bus and operate in both directions, as an input and as an output. RxD and TxD pins are the interface to the CAN controller, the TxD pin is an input pin and the RxD pin is an output pin. The NEN and NRM pins are the input pins for the mode selection (see [Figure 4](#)).

By setting the TxD input pin to logical “low” the transmitter of the TLE7250 drives a “dominant” signal to the CANH and CANL pins. Setting TxD input to logical “high” turns off the transmitter and the output voltage on CANH and CANL discharges towards the “recessive” level. The “recessive” output voltage is provided by the bus-biasing (see [Figure 1](#)). The output of the transmitter is considered to be “dominant”, when the voltage difference between CANH and CANL is at least higher than 1.5 V ( $V_{Diff} = V_{CANH} - V_{CANL}$ ).

Parallel to the transmitter the normal-mode receiver monitors the signal on the CANH and CANL pins and indicates it on the RxD output pin. A “dominant” signal on the CANH and CANL pins sets the RxD output pin to logical “low”, vice versa a “recessive” signal sets the RxD output to logical “high”. The normal-mode receiver considers a voltage difference ( $V_{Diff}$ ) between CANH and CANL above 0.9 V as “dominant” and below 0.5 V as “recessive”.

To be conform with HS CAN features, like the bit to bit arbitration, the signal on the RxD output has to follow the signal on the TxD input within a defined loop delay  $t_{Loop} \leq 255$  ns.

## 4.2 Modes of Operation

The TLE7250 supports three different modes of operation, power-save mode, receive-only mode and normal-operating mode while the transceiver is supplied according to the specified functional range. The mode of operation is selected by the NEN and the NRM input pins (see [Figure 4](#)).

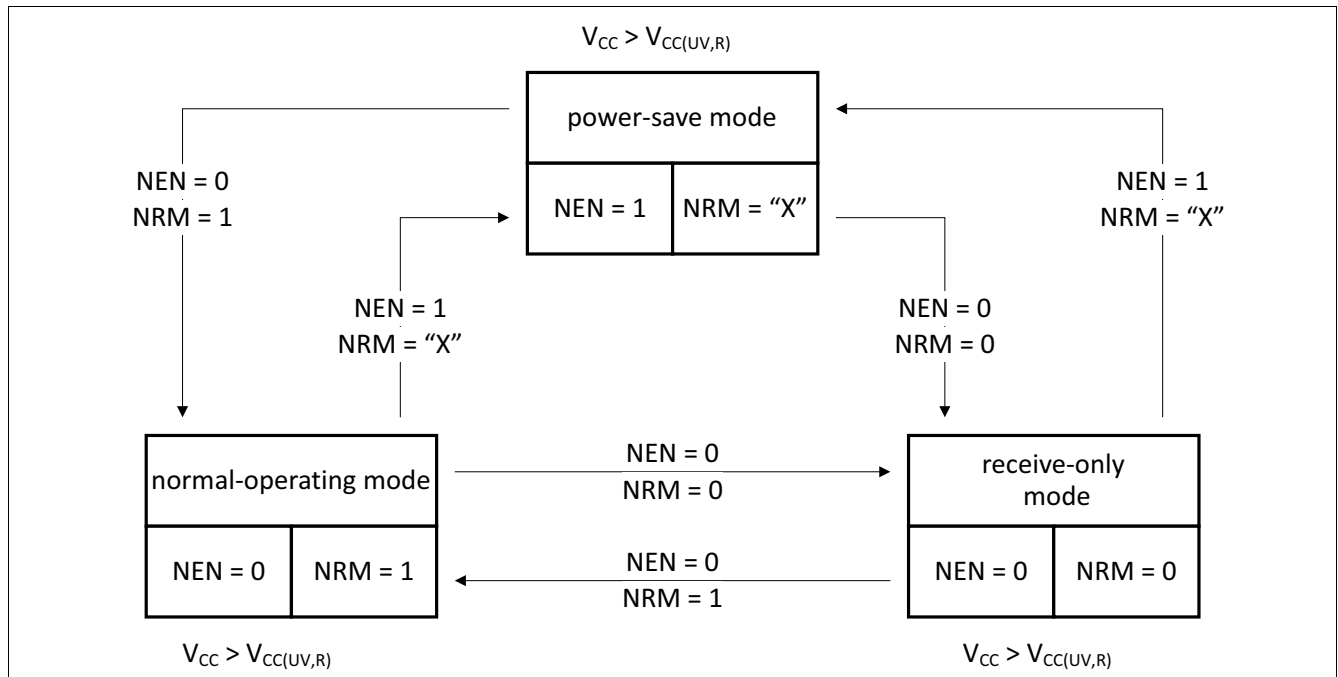

**Figure 4** Mode state diagram

### 4.2.1 Normal-operating Mode

In normal-operating mode the transmitter and the receiver of the HS CAN transceiver TLE7250 are active (see [Figure 1](#)). The HS CAN transceiver sends the serial data stream on the TxD input pin to the CAN bus. The data on the CAN bus is displayed at the RxD pin simultaneously. A logical "low" signal on the NEN pin and a logical "high" signal on the NRM pin selects the normal-operating mode, while the transceiver is supplied by  $V_{CC}$  (see [Table 2](#) for details).

### 4.2.2 Power-save Mode

The power-save mode is an idle mode of the TLE7250 with optimized power consumption. In power-save mode the transmitter and the normal-mode receiver are turned off. The TLE7250 can not send any data to the HS CAN bus nor receive any data from the HS CAN bus.

The RxD output pin is permanently "high" in the power-save mode.

A logical "high" signal on the NEN pin selects the power-save mode, while the transceiver is supplied by the transmitter supply  $V_{CC}$  (see [Table 2](#) for details).

In power-save mode the bus input pins are not biased. Therefore the CANH and CANL input pins are floating and the HS CAN bus interface has a high resistance.

### 4.2.3 Receive-only Mode

In receive-only mode the normal-mode receiver is active and the transmitter is turned off. The TLE7250 can receive data from the HS CAN bus, but cannot send any data to the HS CAN bus.

A logical "low" signal on the NEN pin and a logical "low" signal on the NRM pin selects the receive-only mode, while the transceiver is supplied by  $V_{CC}$  (see [Table 2](#) for details).

### 4.3 Power-up and Undervoltage Condition

By detecting an undervoltage event or by switching off the transmitter power supply  $V_{CC}$ , the transceiver TLE7250 changes the mode of operation (details see [Figure 5](#)).

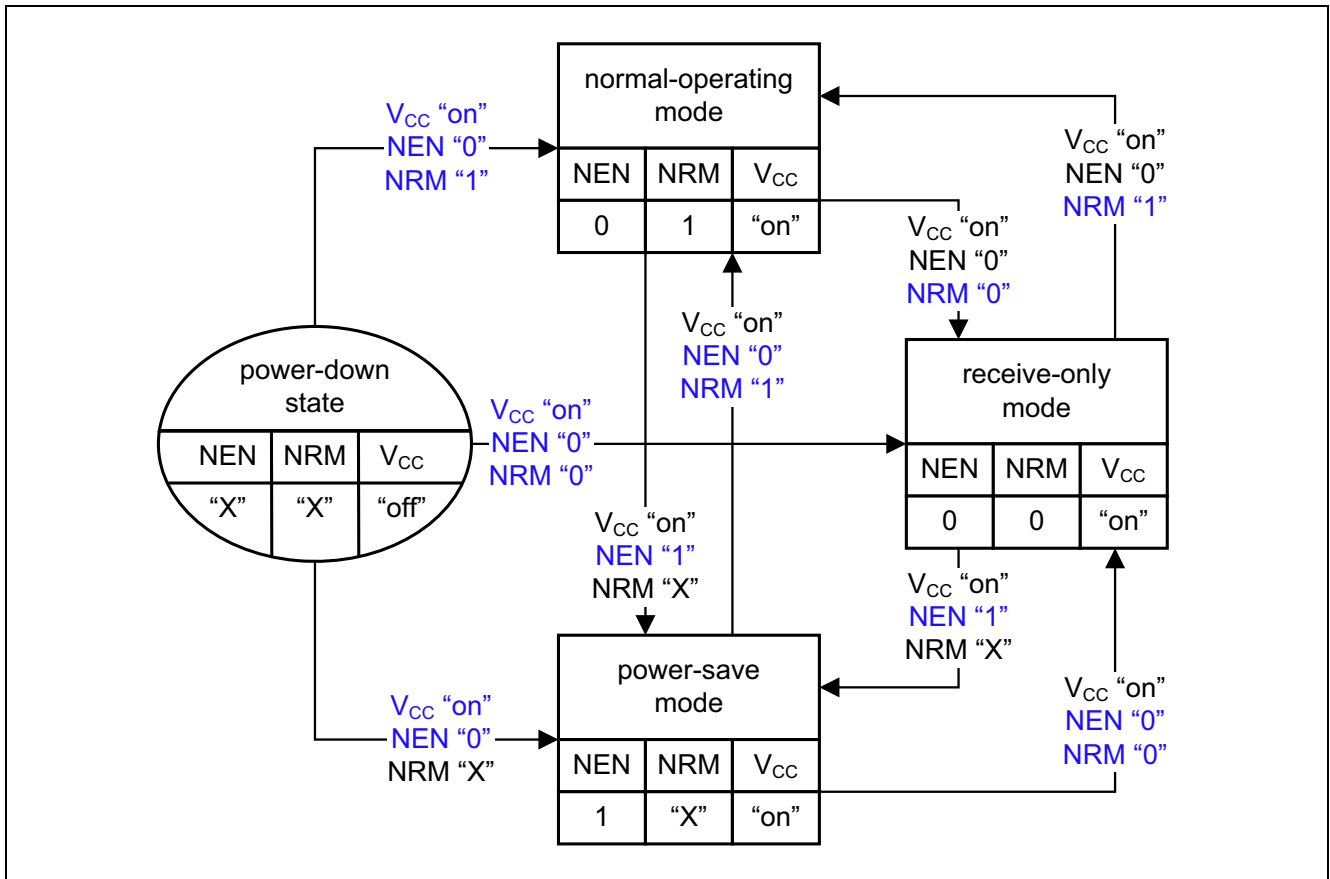

Figure 5 Power-up and undervoltage

Table 2 Modes of operation

| Mode             | NEN    | NRM    | V <sub>CC</sub> | Bus-bias   | Transmitter | Normal-mode Receiver | Low-power Receiver |
|------------------|--------|--------|-----------------|------------|-------------|----------------------|--------------------|
| Normal-operating | "low"  | "high" | "on"            | $V_{CC}/2$ | "on"        | "on"                 | not available      |
| Power-save       | "high" | "X"    | "on"            | floating   | "off"       | "off"                | not available      |
| Receive-only     | "low"  | "low"  | "on"            | $V_{CC}/2$ | "off"       | "on"                 | not available      |
| Power-down state | "X"    | "X"    | "off"           | floating   | "off"       | "off"                | not available      |

### 4.3.1 Power-down State

Independent of the NEN and NRM input pins the TLE7250 is in power-down state when the transmitter supply voltage  $V_{CC}$  is turned off (see [Figure 5](#)).

In the power-down state the input resistors of the receiver are disconnected from the bus biasing  $V_{CC}/2$ . The CANH and CANL bus interface of the TLE7250 is floating and acts as a high-impedance input with a very small leakage current. The high-ohmic input does not influence the “recessive” level of the CAN network and allows an optimized EME performance of the entire HS CAN network (see also [Table 2](#)).

### 4.3.2 Power-up

The HS CAN transceiver TLE7250 powers up if the transmitter supply  $V_{CC}$  is connected to the device. By default the device powers up in power-save mode, due to the internal pull-up resistor on the NEN pin to  $V_{CC}$ .

In case the device needs to power-up to normal-operating mode, the NEN pin needs to be pulled active to logical “low” while the NRM pin is logical “high” (see [Figure 5](#)).

### 4.3.3 Undervoltage on the Transmitter Supply $V_{CC}$

In case the transmitter supply  $V_{CC}$  falls below the threshold  $V_{CC} < V_{CC(UV,F)}$ , the transceiver TLE7250 can not provide the correct bus levels to the CANH and CANL anymore. The normal-mode receiver is powered by the transmitter supply  $V_{CC}$ . In case of insufficient  $V_{CC}$  supply the TLE7250 can neither transmit the CANH and CANL signals correctly to bus nor can it receive them properly. Therefore the TLE7250 powers down and blocks both, the transmitter and the receiver.

The transceiver TLE7250 powers up again, when the transmitter supply  $V_{CC}$  recovers from the undervoltage condition.

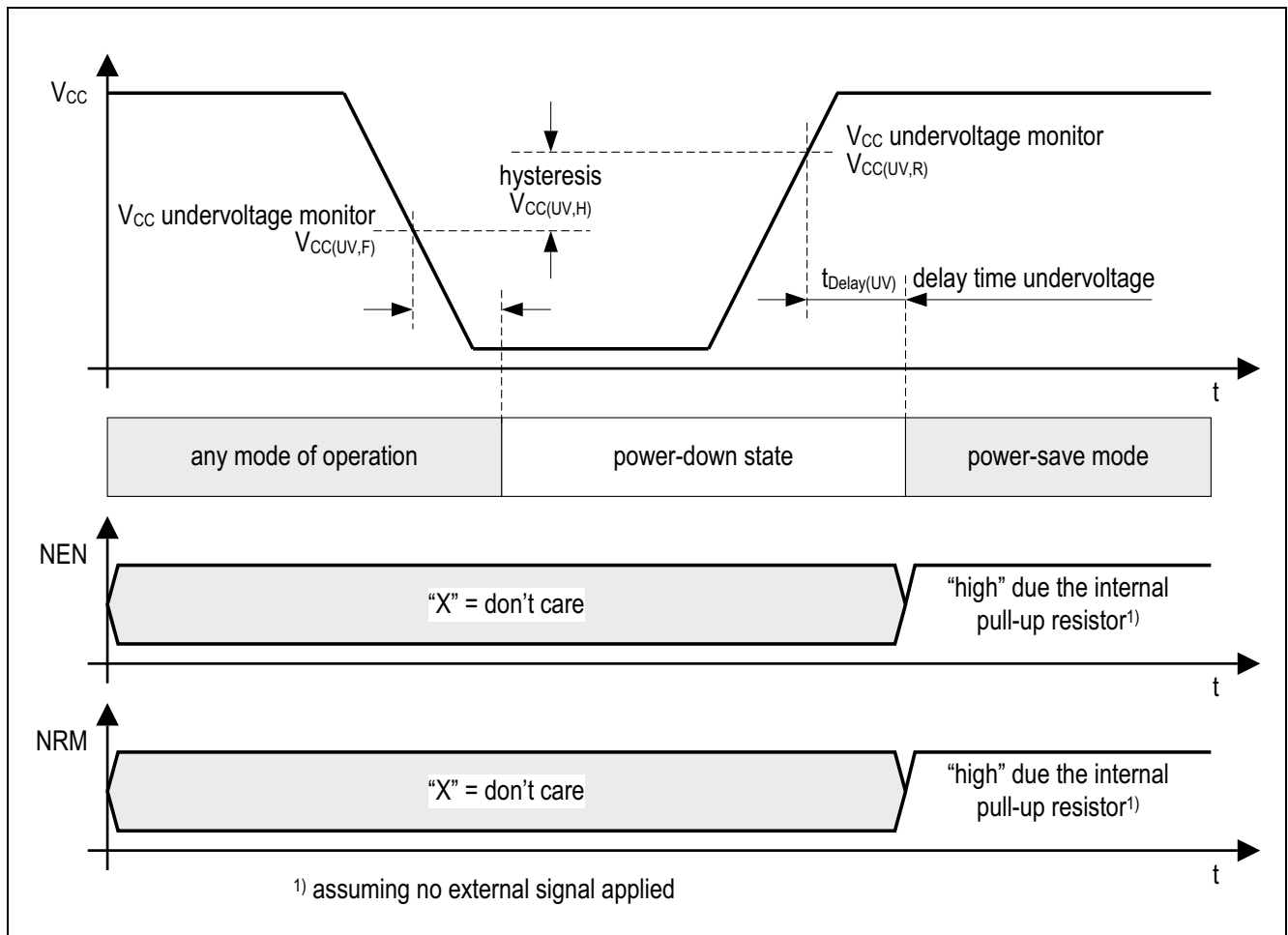

Figure 6 Undervoltage on the transmitter supply  $V_{CC}$

## 5 Fail Safe Functions

### 5.1 Short Circuit Protection

The CANH and CANL bus outputs are short circuit proof, either against GND or a positive supply voltage. A current limiting circuit protects the transceiver against damages. If the device is heating up due to a continuous short on the CANH or CANL, the internal overtemperature protection switches off the bus transmitter.

### 5.2 Unconnected Logic Pins

All logic input pins have an internal pull-up resistor to  $V_{CC}$ . In case the  $V_{CC}$  supply is activated and the logical pins are open, the TLE7250 enters into the power-save mode by default. In power-save mode the transmitter of the TLE7250 is disabled and the bus bias is floating.

### 5.3 TxD Time-out Function

The TxD time-out feature protects the CAN bus against permanent blocking in case the logical signal on the TxD pin is continuously “low”. A continuous “low” signal on the TxD pin might have its root cause in a locked-up microcontroller or in a short circuit on the printed circuit board, for example. In normal-operating mode, a logical “low” signal on the TxD pin for the time  $t > t_{TxD}$  enables the TxD time-out feature and the TLE7250 disables the transmitter (see [Figure 7](#)). The receiver is still active and the data on the bus continues to be monitored by the RxD output pin.

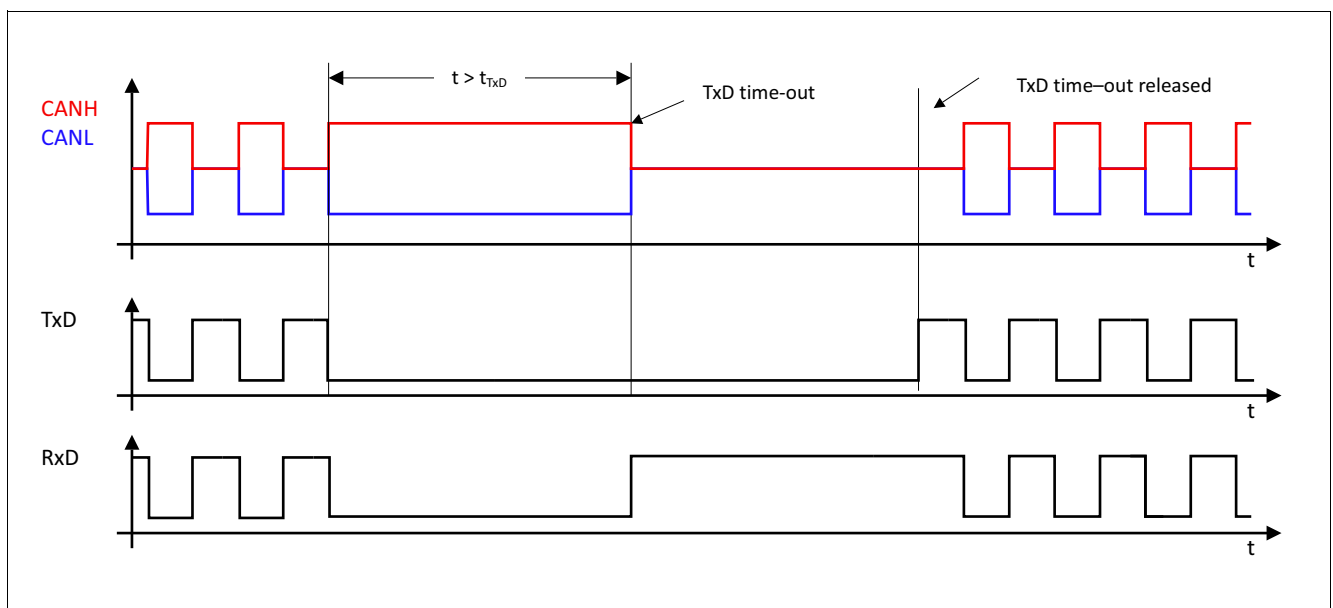

**Figure 7** TxD time-out function

**Figure 7** illustrates how the transmitter is deactivated and activated again. A permanent “low” signal on the TxD input pin activates the TxD time-out function and deactivates the transmitter. To release the transmitter after a TxD time-out event the TLE7250 requires a signal change on the TxD input pin from logical “low” to logical “high”.

## 5.4 Overtemperature Protection

The TLE7250 has an integrated overtemperature detection to protect the TLE7250 against thermal overstress of the transmitter. The overtemperature protection is active in normal-operating mode and disabled in power-save mode and receive-only mode. In case of an overtemperature condition, the temperature sensor will disable the transmitter (see [Figure 1](#)) while the transceiver remains in normal-operating mode.

After the device has cooled down the transmitter is activated again (see [Figure 8](#)). A hysteresis is implemented within the temperature sensor.

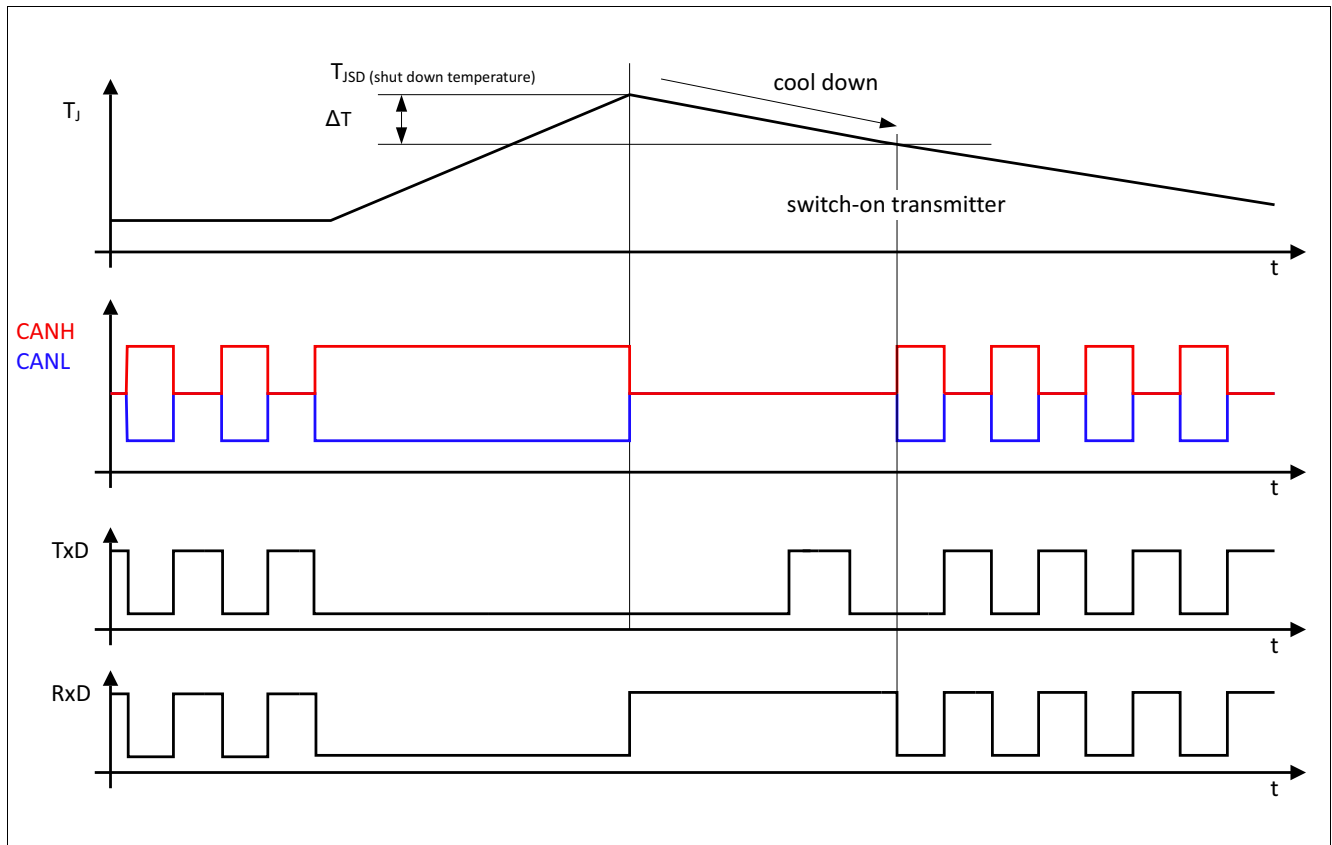

Figure 8 Overtemperature protection

## 5.5 Delay Time for Mode Change

The HS CAN transceiver TLE7250 changes the mode of operation within the time window  $t_{Mode}$ . Depending on the selected mode of operation, the RxD output pin is set to logical "high" during the mode change.

In this case the RxD output does not reflect the status on the CANH and CANL input pins (see as an example [Figure 13](#) and [Figure 14](#)).

## 6 General Product Characteristics

### 6.1 Absolute Maximum Ratings

**Table 3 Absolute maximum ratings voltages, currents and temperatures<sup>1)</sup>**

All voltages with respect to ground; positive current flowing into pin;  
(unless otherwise specified)

| Parameter                                  | Symbol              | Values |      |          | Unit | Note / Test Condition                 | Number   |
|--------------------------------------------|---------------------|--------|------|----------|------|---------------------------------------|----------|
|                                            |                     | Min.   | Typ. | Max.     |      |                                       |          |
| <b>Voltages</b>                            |                     |        |      |          |      |                                       |          |
| Transmitter supply voltage                 | $V_{CC}$            | -0.3   | –    | 6.0      | V    | –                                     | P_6.1.1  |
| CANH DC voltage versus GND                 | $V_{CANH}$          | -40    | –    | 40       | V    | –                                     | P_6.1.2  |
| CANL DC voltage versus GND                 | $V_{CANL}$          | -40    | –    | 40       | V    | –                                     | P_6.1.3  |
| Differential voltage between CANH and CANL | $V_{CAN\ SDiff}$    | -40    | –    | 40       | V    | –                                     | P_6.1.4  |
| Voltages at the input pins: NEN, NRM, TxD  | $V_{MAX\_IN}$       | -0.3   | –    | 6.0      | V    | –                                     | P_6.1.5  |
| Voltages at the output pin: RxD            | $V_{MAX\_OUT}$      | -0.3   | –    | $V_{CC}$ | V    | –                                     | P_6.1.6  |
| <b>Currents</b>                            |                     |        |      |          |      |                                       |          |
| RxD output current                         | $I_{RxD}$           | -20    | –    | 20       | mA   | –                                     | P_6.1.7  |
| <b>Temperatures</b>                        |                     |        |      |          |      |                                       |          |
| Junction temperature                       | $T_j$               | -40    | –    | 150      | °C   | –                                     | P_6.1.8  |
| Storage temperature                        | $T_S$               | -55    | –    | 150      | °C   | –                                     | P_6.1.9  |
| <b>ESD Resistivity</b>                     |                     |        |      |          |      |                                       |          |
| ESD immunity at CANH, CANL versus GND      | $V_{ESD\_HBM\_CAN}$ | -9     | –    | 9        | kV   | HBM (100 pF via 1.5 kΩ) <sup>2)</sup> | P_6.1.10 |
| ESD immunity at all other pins             | $V_{ESD\_HBM\_ALL}$ | -2     | –    | 2        | kV   | HBM (100 pF via 1.5 kΩ) <sup>2)</sup> | P_6.1.11 |
| ESD immunity to GND                        | $V_{ESD\_CDM}$      | -750   | –    | 750      | V    | CDM <sup>3)</sup>                     | P_6.1.12 |

1) Not subject to production test, specified by design

2) ESD susceptibility, Human Body Model "HBM" according to ANSI/ESDA/JEDEC JS-001

3) ESD susceptibility, Charge Device Model "CDM" according to EIA/JESD22-C101 or ESDA STM5.3.1

*Note: Stresses above the ones listed here may cause permanent damage to the device. Exposure to absolute maximum rating conditions for extended periods may affect device reliability. Integrated protection functions are designed to prevent IC destruction under fault conditions described in the data sheet. Fault conditions are considered as "outside" normal-operating range. Protection functions are not designed for continuous repetitive operation.*

## 6.2 Functional Range

**Table 4 Functional range**

| Parameter                  | Symbol   | Values |      |      | Unit | Note / Test Condition | Number  |
|----------------------------|----------|--------|------|------|------|-----------------------|---------|
|                            |          | Min.   | Typ. | Max. |      |                       |         |
| <b>Supply Voltages</b>     |          |        |      |      |      |                       |         |
| Transmitter supply voltage | $V_{CC}$ | 4.5    | –    | 5.5  | V    | –                     | P_6.2.1 |
| <b>Thermal Parameters</b>  |          |        |      |      |      |                       |         |
| Junction temperature       | $T_j$    | -40    | –    | 150  | °C   | 1)                    | P_6.2.2 |

1) Not subject to production test, specified by design.

*Note: Within the functional range the IC operates as described in the circuit description. The electrical characteristics are specified within the conditions given in the related electrical characteristics table.*

## 6.3 Thermal Resistance

*Note: This thermal data was generated in accordance with JEDEC JESD51 standards. For more information, please visit [www.jedec.org](http://www.jedec.org).*

**Table 5 Thermal resistance<sup>1)</sup>**

| Parameter                                      | Symbol     | Values |      |      | Unit | Note / Test Condition   | Number  |
|------------------------------------------------|------------|--------|------|------|------|-------------------------|---------|
|                                                |            | Min.   | Typ. | Max. |      |                         |         |
| <b>Thermal Resistances</b>                     |            |        |      |      |      |                         |         |
| Junction to Ambient PG-TSON-8                  | $R_{thJA}$ | –      | 55   | –    | K/W  | <sup>2)</sup> TLE7250LE | P_6.3.1 |
| Junction to Ambient PG-DSO-8                   | $R_{thJA}$ | –      | 130  | –    | K/W  | <sup>2)</sup> TLE7250SJ | P_6.3.4 |
| <b>Thermal Shutdown (junction temperature)</b> |            |        |      |      |      |                         |         |
| Thermal shutdown temperature                   | $T_{JSD}$  | 150    | 175  | 200  | °C   | –                       | P_6.3.2 |
| Thermal shutdown hysteresis                    | $\Delta T$ | –      | 10   | –    | K    | –                       | P_6.3.3 |

1) Not subject to production test, specified by design

2) Specified  $R_{thJA}$  value is according to Jedec JESD51-2,-7 at natural convection on FR4 2s2p board. The product (TLE7250) was simulated on a 76.2 x 114.3 x 1.5 mm board with 2 inner copper layers (2 x 70µm Cu, 2 x 35µm Cu).

## 7 Electrical Characteristics

### 7.1 Functional Device Characteristics

**Table 6 Electrical characteristics**

4.5 V <  $V_{CC}$  < 5.5 V;  $R_L = 60 \Omega$ ;  $-40 \text{ }^\circ\text{C} < T_j < 150 \text{ }^\circ\text{C}$ ; all voltages with respect to ground; positive current flowing into pin; unless otherwise specified.

| Parameter                                             | Symbol                 | Values |      |      | Unit          | Note / Test Condition                                                             | Number   |
|-------------------------------------------------------|------------------------|--------|------|------|---------------|-----------------------------------------------------------------------------------|----------|
|                                                       |                        | Min.   | Typ. | Max. |               |                                                                                   |          |
| <b>Current Consumption</b>                            |                        |        |      |      |               |                                                                                   |          |
| Current consumption at $V_{CC}$ normal-operating mode | $I_{CC}$               | –      | 2.6  | 5    | mA            | “recessive” state,<br>$V_{TXD} = V_{NRM} = V_{CC}$ ,<br>$V_{NEN} = 0 \text{ V}$ ; | P_7.1.1  |
| Current consumption at $V_{CC}$ normal-operating mode | $I_{CC}$               | –      | 38   | 60   | mA            | “dominant” state,<br>$V_{TXD} = V_{NEN} = 0 \text{ V}$ ,<br>$V_{NRM} = V_{CC}$ ;  | P_7.1.2  |
| Current consumption at $V_{CC}$ receive-only mode     | $I_{CC(ROM)}$          | –      | 2    | 3    | mA            | $V_{NEN} = V_{NRM} = 0 \text{ V}$ ;                                               | P_7.1.3  |
| Current consumption at $V_{CC}$ power-save mode       | $I_{CC(PSM)}$          | –      | 5    | 12   | $\mu\text{A}$ | $V_{TXD} = V_{NEN} = V_{NRM} = V_{CC}$ ;                                          | P_7.1.4  |
| <b>Supply Resets</b>                                  |                        |        |      |      |               |                                                                                   |          |
| $V_{CC}$ undervoltage monitor rising edge             | $V_{CC(UV,R)}$         | 3.8    | 4.0  | 4.3  | V             | –                                                                                 | P_7.1.5  |
| $V_{CC}$ undervoltage monitor falling edge            | $V_{CC(UV,F)}$         | 3.65   | 3.85 | 4.3  | V             | –                                                                                 | P_7.1.52 |
| $V_{CC}$ undervoltage monitor hysteresis              | $V_{CC(UV,H)}$         | –      | 150  | –    | mV            | <sup>1)</sup>                                                                     | P_7.1.6  |
| $V_{CC}$ undervoltage delay time                      | $t_{\text{Delay(UV)}}$ | –      | –    | 100  | $\mu\text{s}$ | <sup>1)</sup> (see <a href="#">Figure 6</a> );                                    | P_7.1.7  |
| <b>Receiver Output RxD</b>                            |                        |        |      |      |               |                                                                                   |          |
| “High” level output current                           | $I_{RD,H}$             | –      | -4   | -2   | mA            | $V_{RXD} = V_{CC} - 0.4 \text{ V}$ ,<br>$V_{\text{Diff}} < 0.5 \text{ V}$ ;       | P_7.1.8  |
| “Low” level output current                            | $I_{RD,L}$             | 2      | 4    | –    | mA            | $V_{RXD} = 0.4 \text{ V}$ , $V_{\text{Diff}} > 0.9 \text{ V}$ ;                   | P_7.1.9  |

**Table 6 Electrical characteristics (cont'd)**

4.5 V <  $V_{CC}$  < 5.5 V;  $R_L = 60 \Omega$ ;  $-40 \text{ }^\circ\text{C} < T_j < 150 \text{ }^\circ\text{C}$ ; all voltages with respect to ground; positive current flowing into pin; unless otherwise specified.

| Parameter                                                                               | Symbol                | Values                     |                            |                            | Unit       | Note / Test Condition                     | Number   |
|-----------------------------------------------------------------------------------------|-----------------------|----------------------------|----------------------------|----------------------------|------------|-------------------------------------------|----------|
|                                                                                         |                       | Min.                       | Typ.                       | Max.                       |            |                                           |          |
| <b>Transmission Input TxD</b>                                                           |                       |                            |                            |                            |            |                                           |          |
| “High” level input voltage threshold                                                    | $V_{\text{TxD,H}}$    | –                          | $0.5 \times V_{\text{CC}}$ | $0.7 \times V_{\text{CC}}$ | V          | “recessive” state;                        | P_7.1.10 |
| “Low” level input voltage threshold                                                     | $V_{\text{TxD,L}}$    | $0.3 \times V_{\text{CC}}$ | $0.4 \times V_{\text{CC}}$ | –                          | V          | “dominant” state;                         | P_7.1.11 |
| Pull-up resistance                                                                      | $R_{\text{TxD}}$      | 10                         | 25                         | 50                         | k $\Omega$ | –                                         | P_7.1.12 |
| Input hysteresis                                                                        | $V_{\text{HYS(TxD)}}$ | –                          | 450                        | –                          | mV         | <sup>1)</sup>                             | P_7.1.13 |
| Input capacitance                                                                       | $C_{\text{TxD}}$      | –                          | –                          | 10                         | pF         | <sup>1)</sup>                             | P_7.1.14 |
| TxD permanent “dominant” time-out                                                       | $t_{\text{TxD}}$      | 4.5                        | –                          | 16                         | ms         | normal-operating mode;                    | P_7.1.15 |
| <b>Not Enable Input NEN</b>                                                             |                       |                            |                            |                            |            |                                           |          |
| “High” level input voltage threshold                                                    | $V_{\text{NEN,H}}$    | –                          | $0.5 \times V_{\text{CC}}$ | $0.7 \times V_{\text{CC}}$ | V          | power-save mode;                          | P_7.1.16 |
| “Low” level input voltage threshold                                                     | $V_{\text{NEN,L}}$    | $0.3 \times V_{\text{CC}}$ | $0.4 \times V_{\text{CC}}$ | –                          | V          | normal-operating mode, receive-only mode; | P_7.1.17 |
| Pull-up resistance                                                                      | $R_{\text{NEN}}$      | 10                         | 25                         | 50                         | k $\Omega$ | –                                         | P_7.1.18 |
| Input capacitance                                                                       | $C_{\text{NEN}}$      | –                          | –                          | 10                         | pF         | <sup>1)</sup>                             | P_7.1.19 |
| Input hysteresis                                                                        | $V_{\text{HYS(NEN)}}$ | –                          | 200                        | –                          | mV         | <sup>1)</sup>                             | P_7.1.20 |
| <b>Not Receive-only Input NRM</b>                                                       |                       |                            |                            |                            |            |                                           |          |
| “High” level input voltage threshold                                                    | $V_{\text{NRM,H}}$    | –                          | $0.5 \times V_{\text{CC}}$ | $0.7 \times V_{\text{CC}}$ | V          | normal-operating mode, power-save mode;   | P_7.1.21 |
| “Low” level input voltage threshold                                                     | $V_{\text{NRM,L}}$    | $0.3 \times V_{\text{CC}}$ | $0.4 \times V_{\text{CC}}$ | –                          | V          | receive-only mode, power-save mode;       | P_7.1.22 |
| Pull-up resistance                                                                      | $R_{\text{NRM}}$      | 10                         | 25                         | 50                         | k $\Omega$ | –                                         | P_7.1.23 |
| Input capacitance                                                                       | $C_{\text{NRM}}$      | –                          | –                          | 10                         | pF         | <sup>1)</sup>                             | P_7.1.24 |
| Input hysteresis                                                                        | $V_{\text{NRM(HYS)}}$ | –                          | 200                        | –                          | mV         | <sup>1)</sup>                             | P_7.1.25 |
| <b>Bus Receiver</b>                                                                     |                       |                            |                            |                            |            |                                           |          |
| Differential receiver threshold “dominant” normal-operating mode and receive-only mode  | $V_{\text{Diff\_D}}$  | –                          | 0.75                       | 0.9                        | V          | <sup>2)</sup>                             | P_7.1.26 |
| Differential receiver threshold “recessive” normal-operating mode and receive-only mode | $V_{\text{Diff\_R}}$  | 0.5                        | 0.66                       | –                          | V          | <sup>2)</sup>                             | P_7.1.27 |
| Common mode range                                                                       | $CMR$                 | -12                        | –                          | 12                         | V          | $V_{\text{CC}} = 5 \text{ V}$ ;           | P_7.1.28 |
| Differential receiver hysteresis normal-operating mode                                  | $V_{\text{Diff,hys}}$ | –                          | 90                         | –                          | mV         | <sup>1)</sup>                             | P_7.1.29 |
| CANH, CANL input resistance                                                             | $R_i$                 | 10                         | 20                         | 30                         | k $\Omega$ | “recessive” state;                        | P_7.1.30 |

**Table 6 Electrical characteristics (cont'd)**

4.5 V <  $V_{CC}$  < 5.5 V;  $R_L = 60 \Omega$ ;  $-40 \text{ }^\circ\text{C} < T_j < 150 \text{ }^\circ\text{C}$ ; all voltages with respect to ground; positive current flowing into pin; unless otherwise specified.

| Parameter                                                                                                                          | Symbol          | Values |      |      | Unit          | Note / Test Condition                                                                                       | Number   |
|------------------------------------------------------------------------------------------------------------------------------------|-----------------|--------|------|------|---------------|-------------------------------------------------------------------------------------------------------------|----------|
|                                                                                                                                    |                 | Min.   | Typ. | Max. |               |                                                                                                             |          |
| Differential input resistance                                                                                                      | $R_{Diff}$      | 20     | 40   | 60   | k $\Omega$    | "recessive" state;                                                                                          | P_7.1.31 |
| Input resistance deviation between CANH and CANL                                                                                   | $\Delta R_i$    | - 1    | -    | 1    | %             | <sup>1)</sup> "recessive" state;                                                                            | P_7.1.32 |
| Input capacitance CANH, CANL versus GND                                                                                            | $C_{In}$        | -      | 20   | 40   | pF            | <sup>1)</sup> $V_{TxD} = V_{CC}$ ;                                                                          | P_7.1.33 |
| Differential input capacitance                                                                                                     | $C_{InDiff}$    | -      | 10   | 20   | pF            | <sup>1)</sup> $V_{TxD} = V_{CC}$ ;                                                                          | P_7.1.34 |
| <b>Bus Transmitter</b>                                                                                                             |                 |        |      |      |               |                                                                                                             |          |
| CANL/CANH "recessive" output voltage normal-operating mode                                                                         | $V_{CANL/H}$    | 2.0    | 2.5  | 3.0  | V             | $V_{TxD} = V_{CC}$ , no load;                                                                               | P_7.1.35 |
| CANH, CANL "recessive" output voltage difference normal-operating mode                                                             | $V_{Diff\_NM}$  | -500   | -    | 50   | mV            | $V_{TxD} = V_{CC}$ , no load;                                                                               | P_7.1.36 |
| CANL "dominant" output voltage normal-operating mode                                                                               | $V_{CANL}$      | 0.5    | -    | 2.25 | V             | $V_{TxD} = 0 \text{ V}$ ;                                                                                   | P_7.1.37 |
| CANH "dominant" output voltage normal-operating mode                                                                               | $V_{CANH}$      | 2.75   | -    | 4.5  | V             | $V_{TxD} = 0 \text{ V}$ ;                                                                                   | P_7.1.38 |
| CANH, CANL "dominant" output voltage difference normal-operating mode according to ISO 11898-2<br>$V_{Diff} = V_{CANH} - V_{CANL}$ | $V_{Diff}$      | 1.5    | -    | 3.0  | V             | $V_{TxD} = 0 \text{ V}$ ,<br>$50 \Omega < R_L < 65 \Omega$ ,<br>$4.75 < V_{CC} < 5.25 \text{ V}$ ;          | P_7.1.39 |
| CANH, CANL "dominant" output voltage difference normal-operating mode<br>$V_{Diff} = V_{CANH} - V_{CANL}$                          | $V_{Diff\_R45}$ | 1.4    | -    | 3.0  | V             | $V_{TxD} = 0 \text{ V}$ ,<br>$45 \Omega < R_L < 50 \Omega$ ,<br>$4.75 < V_{CC} < 5.25 \text{ V}$ ;          | P_7.1.53 |
| Driver "dominant" symmetry normal-operating mode<br>$V_{SYM} = V_{CANH} + V_{CANL}$                                                | $V_{SYM}$       | 4.5    | 5    | 5.5  | V             | $V_{CC} = 5.0 \text{ V}$ , $V_{TxD} = 0 \text{ V}$ ;                                                        | P_7.1.40 |
| CANL short circuit current                                                                                                         | $I_{CANLsc}$    | 40     | 75   | 100  | mA            | $V_{CANLshort} = 18 \text{ V}$ ,<br>$V_{CC} = 5.0 \text{ V}$ , $t < t_{TxD}$ ,<br>$V_{TxD} = 0 \text{ V}$ ; | P_7.1.41 |
| CANH short circuit current                                                                                                         | $I_{CANHsc}$    | -100   | -75  | -40  | mA            | $V_{CANHshort} = 0 \text{ V}$ ,<br>$V_{CC} = 5.0 \text{ V}$ , $t < t_{TxD}$ ,<br>$V_{TxD} = 0 \text{ V}$ ;  | P_7.1.42 |
| Leakage current, CANH                                                                                                              | $I_{CANH,IK}$   | -5     | -    | 5    | $\mu\text{A}$ | $V_{CC} = 0 \text{ V}$ ,<br>$0 \text{ V} < V_{CANH} < 5 \text{ V}$ ,<br>$V_{CANH} = V_{CANL}$ ;             | P_7.1.43 |

**Table 6 Electrical characteristics (cont'd)**

4.5 V <  $V_{CC}$  < 5.5 V;  $R_L = 60 \Omega$ ;  $-40 \text{ }^\circ\text{C} < T_j < 150 \text{ }^\circ\text{C}$ ; all voltages with respect to ground; positive current flowing into pin; unless otherwise specified.

| Parameter             | Symbol        | Values |      |      | Unit          | Note / Test Condition                                                                           | Number   |
|-----------------------|---------------|--------|------|------|---------------|-------------------------------------------------------------------------------------------------|----------|
|                       |               | Min.   | Typ. | Max. |               |                                                                                                 |          |
| Leakage current, CANL | $I_{CANL,IK}$ | -5     | –    | 5    | $\mu\text{A}$ | $V_{CC} = 0 \text{ V}$ ,<br>$0 \text{ V} < V_{CANL} < 5 \text{ V}$ ,<br>$V_{CANH} = V_{CANL}$ ; | P_7.1.44 |

**Dynamic CAN-Transceiver Characteristics**

|                                                                                        |                      |   |     |     |    |                                                                                                                                            |          |
|----------------------------------------------------------------------------------------|----------------------|---|-----|-----|----|--------------------------------------------------------------------------------------------------------------------------------------------|----------|
| Propagation delay<br>TxD-to-RxD “low”<br>(“recessive to “dominant”)                    | $t_{Loop(H,L)}$      | – | 180 | 255 | ns | $C_L = 100 \text{ pF}$ ,<br>$4.75 \text{ V} < V_{CC} < 5.25 \text{ V}$ ,<br>$C_{RxD} = 15 \text{ pF}$ ;                                    | P_7.1.45 |
| Propagation delay<br>TxD-to-RxD “high”<br>(“dominant” to “recessive”)                  | $t_{Loop(L,H)}$      | – | 180 | 255 | ns | $C_L = 100 \text{ pF}$ ,<br>$4.75 \text{ V} < V_{CC} < 5.25 \text{ V}$ ,<br>$C_{RxD} = 15 \text{ pF}$ ;                                    | P_7.1.46 |
| Propagation delay<br>extended load<br>TxD-to-RxD “low”<br>(“recessive to “dominant”)   | $t_{Loop\_Ext(H,L)}$ | – | –   | 300 | ns | <sup>1)</sup> $C_L = 200 \text{ pF}$ , $R_L = 120 \Omega$ ,<br>$4.75 \text{ V} < V_{CC} < 5.25 \text{ V}$ ,<br>$C_{RxD} = 15 \text{ pF}$ ; | P_7.1.54 |
| Propagation delay<br>extended load<br>TxD-to-RxD “high”<br>(“dominant” to “recessive”) | $t_{Loop\_Ext(L,H)}$ | – | –   | 300 | ns | <sup>1)</sup> $C_L = 200 \text{ pF}$ , $R_L = 120 \Omega$ ,<br>$4.75 \text{ V} < V_{CC} < 5.25 \text{ V}$ ,<br>$C_{RxD} = 15 \text{ pF}$ ; | P_7.1.55 |
| Propagation delay<br>TxD “low” to bus “dominant”                                       | $t_{d(L),T}$         | – | 90  | 140 | ns | $C_L = 100 \text{ pF}$ ,<br>$4.75 \text{ V} < V_{CC} < 5.25 \text{ V}$ ,<br>$C_{RxD} = 15 \text{ pF}$ ;                                    | P_7.1.47 |
| Propagation delay<br>TxD “high” to bus “recessive”                                     | $t_{d(H),T}$         | – | 90  | 140 | ns | $C_L = 100 \text{ pF}$ ,<br>$4.75 \text{ V} < V_{CC} < 5.25 \text{ V}$ ,<br>$C_{RxD} = 15 \text{ pF}$ ;                                    | P_7.1.48 |
| Propagation delay<br>bus “dominant” to RxD “low”                                       | $t_{d(L),R}$         | – | 90  | 140 | ns | $C_L = 100 \text{ pF}$ ,<br>$4.75 \text{ V} < V_{CC} < 5.25 \text{ V}$ ,<br>$C_{RxD} = 15 \text{ pF}$ ;                                    | P_7.1.49 |
| Propagation delay<br>bus “recessive” to RxD “high”                                     | $t_{d(H),R}$         | – | 90  | 140 | ns | $C_L = 100 \text{ pF}$ ,<br>$4.75 \text{ V} < V_{CC} < 5.25 \text{ V}$ ,<br>$C_{RxD} = 15 \text{ pF}$ ;                                    | P_7.1.50 |

**Delay Times**

|                            |            |   |   |    |               |                                                                               |          |
|----------------------------|------------|---|---|----|---------------|-------------------------------------------------------------------------------|----------|
| Delay time for mode change | $t_{Mode}$ | – | – | 20 | $\mu\text{s}$ | <sup>1)</sup> (see <a href="#">Figure 13</a> and <a href="#">Figure 14</a> ); | P_7.1.51 |
|----------------------------|------------|---|---|----|---------------|-------------------------------------------------------------------------------|----------|

**Table 6 Electrical characteristics (cont'd)**

4.5 V <  $V_{CC}$  < 5.5 V;  $R_L = 60 \Omega$ ;  $-40 \text{ }^\circ\text{C} < T_j < 150 \text{ }^\circ\text{C}$ ; all voltages with respect to ground; positive current flowing into pin; unless otherwise specified.

| Parameter                                                                                                   | Symbol                             | Values |      |      | Unit | Note / Test Condition                                                                                                                                                                   | Number   |
|-------------------------------------------------------------------------------------------------------------|------------------------------------|--------|------|------|------|-----------------------------------------------------------------------------------------------------------------------------------------------------------------------------------------|----------|
|                                                                                                             |                                    | Min.   | Typ. | Max. |      |                                                                                                                                                                                         |          |
| <b>CAN FD Characteristics</b>                                                                               |                                    |        |      |      |      |                                                                                                                                                                                         |          |
| Received recessive bit width at 2 MBit/s                                                                    | $t_{\text{Bit(RxD)}}_{2\text{MB}}$ | 400    | 500  | 550  | ns   | $C_L = 100 \text{ pF}$ ,<br>$4.75 \text{ V} < V_{CC} < 5.25 \text{ V}$ ,<br>$C_{\text{RxD}} = 15 \text{ pF}$ , $t_{\text{Bit}} = 500 \text{ ns}$ ,<br>(see <a href="#">Figure 11</a> ); | P_7.1.59 |
| Transmitted recessive bit width at 2 MBit/s                                                                 | $t_{\text{Bit(Bus)}}_{2\text{MB}}$ | 435    | 500  | 530  | ns   | $C_L = 100 \text{ pF}$ ,<br>$4.75 \text{ V} < V_{CC} < 5.25 \text{ V}$ ,<br>$C_{\text{RxD}} = 15 \text{ pF}$ , $t_{\text{Bit}} = 500 \text{ ns}$ ,<br>(see <a href="#">Figure 11</a> ); | P_7.1.56 |
| Receiver timing symmetry at 2 MBit/s<br>$\Delta t_{\text{Rec}} = t_{\text{Bit(RxD)}} - t_{\text{Bit(Bus)}}$ | $\Delta t_{\text{Rec}_2\text{MB}}$ | -65    | –    | 40   | ns   | $C_L = 100 \text{ pF}$ ,<br>$4.75 \text{ V} < V_{CC} < 5.25 \text{ V}$ ,<br>$C_{\text{RxD}} = 15 \text{ pF}$ , $t_{\text{Bit}} = 500 \text{ ns}$ ,<br>(see <a href="#">Figure 11</a> ); | P_7.1.57 |

- 1) Not subject to production test, specified by design.
- 2) In respect to the common mode range.

## 7.2 Diagrams

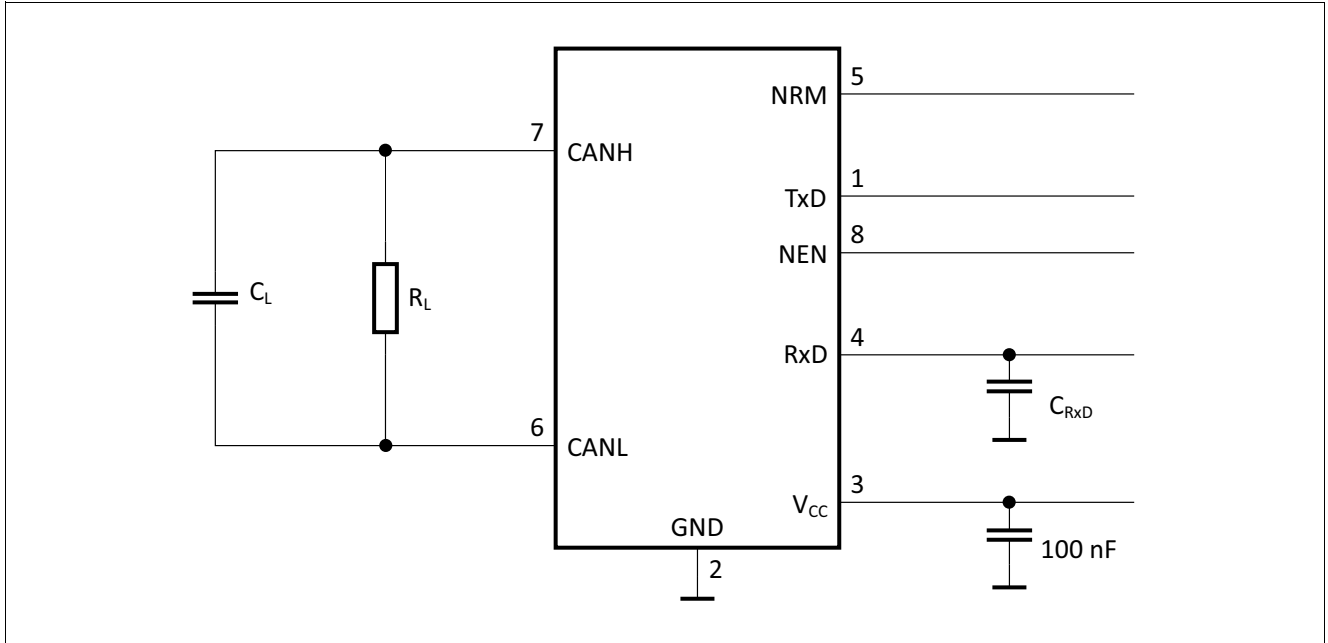

Figure 9 Test circuits for dynamic characteristics

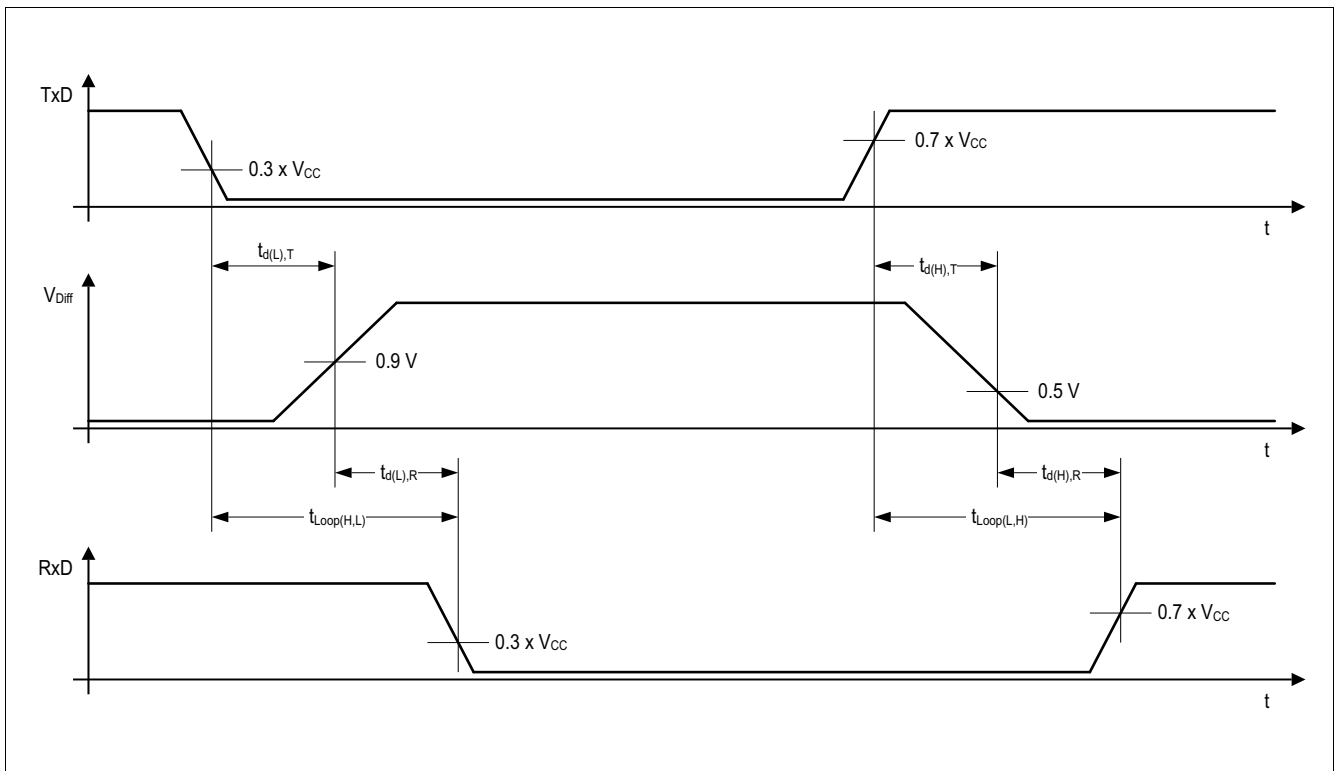

Figure 10 Timing diagrams for dynamic characteristics

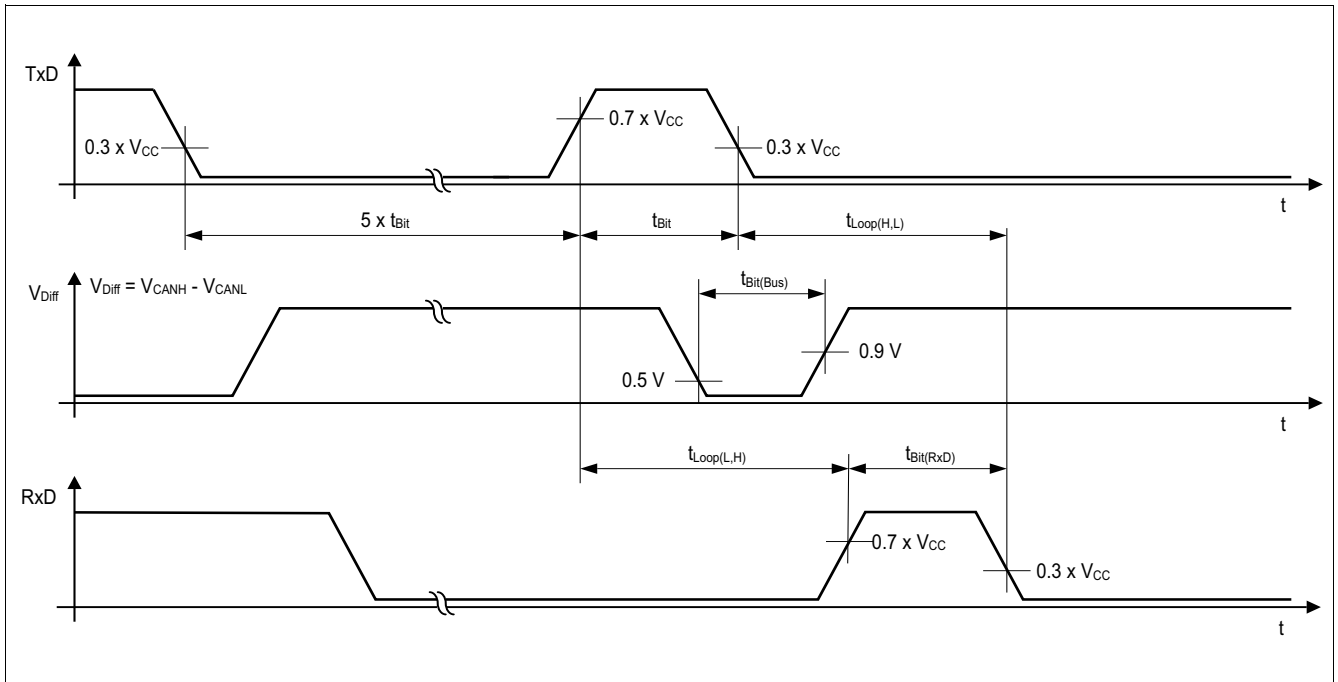

Figure 11 “Recessive” bit width - five “dominant” bits followed by one “recessive” bit

## 8 Application Information

### 8.1 ESD Robustness according to IEC61000-4-2

Test for ESD robustness according to IEC61000-4-2 "Gun test" (150 pF, 330 Ω) have been performed. The results and test conditions are available in a separate test report.

**Table 7 ESD robustness according to IEC61000-4-2**

| Performed Test                                                  | Result | Unit | Remarks                      |
|-----------------------------------------------------------------|--------|------|------------------------------|
| Electrostatic discharge voltage at pin CANH and CANL versus GND | ≥ +8   | kV   | <sup>1)</sup> Positive pulse |
| Electrostatic discharge voltage at pin CANH and CANL versus GND | ≤ -8   | kV   | <sup>1)</sup> Negative pulse |

1) ESD susceptibility "ESD GUN" according to GIFT / ICT paper: "EMC Evaluation of CAN Transceivers, version 03/02/IEC TS62228", section 4.3. (DIN EN61000-4-2)

Tested by external test facility (IBEE Zwickau, EMC test report no. TBD).

## 8.2 Application Example

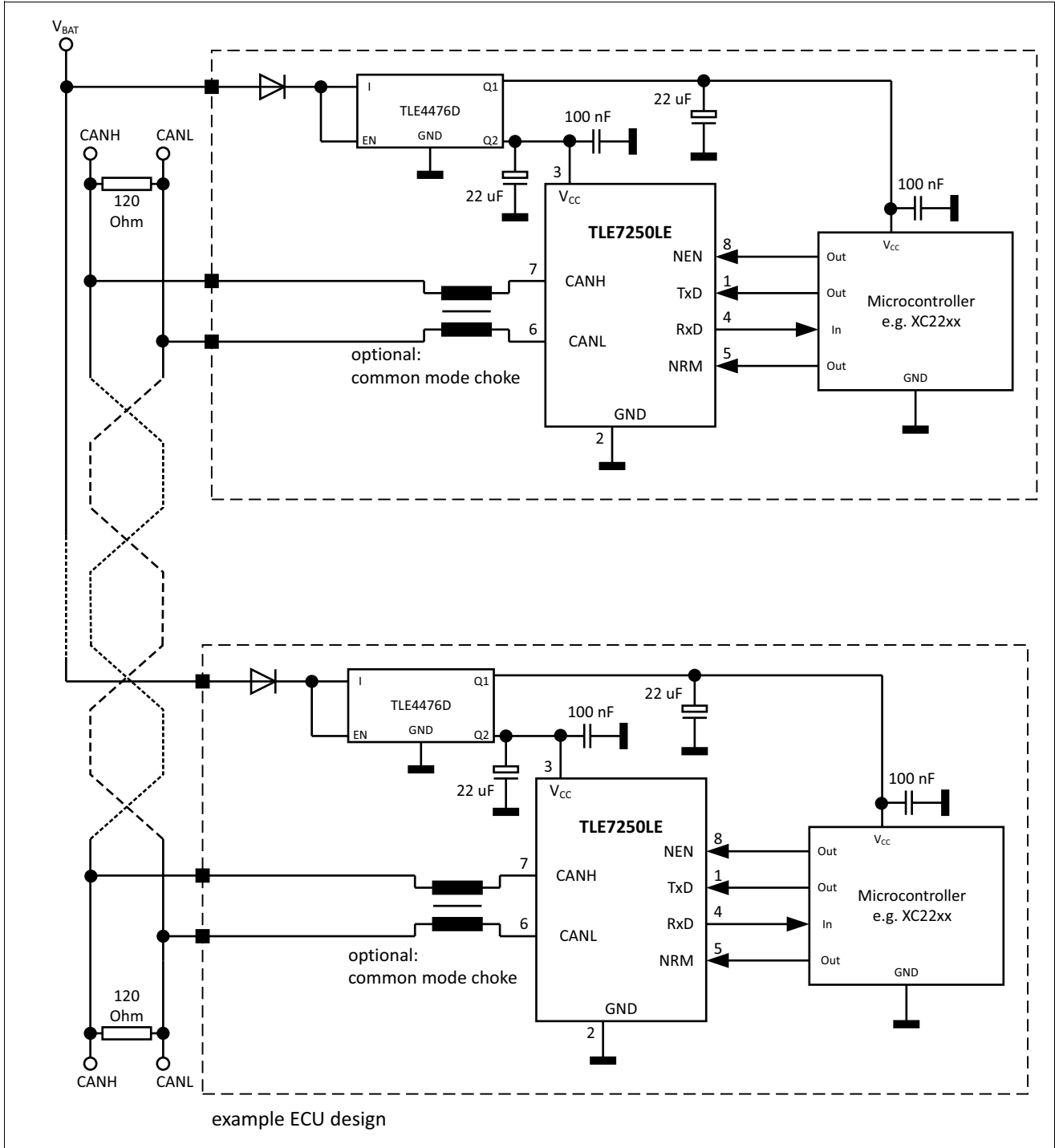

Figure 12 Application circuit

### 8.3 Examples for Mode Changes

Changing the status on the NRM or NEN input pin triggers a change of the operating mode, disregarding the actual signal on the CANH, CANL and TxD pins (see also [Chapter 4.2](#)).

Mode changes are triggered by the NRM pin and NEN pin, when the device TLE7250 is fully supplied. Setting the NEN pin to logical “low” and the NRM pin to logical “high” changes the mode of operation to normal-operating mode:

- The mode change is executed independently of the signal on the HS CAN bus. The CANH, CANL inputs may be either “dominant” or “recessive”. They can be also permanently shorted to GND or  $V_{CC}$ .
- A mode change is performed independently of the signal on the TxD input. The TxD input may be either logical “high” or “low”.

Analog to that, changing the NEN input pin to logical “high” changes the mode of operation to the power-save mode. Changing the NEN input pin and the NRM input pin to logical “low” changes the mode of operation to the receive-only mode. Both mode changes are independent on the signals at the CANH, CANL and TxD pins.

*Note: In case the TxD signal is “low” setting the NRM input pin to logical “high” and the NEN input pin to logical “low” changes the device to normal-operating mode and drives a “dominant” signal to the HS CAN bus”.*

*Note: The TxD time-out is only effective in normal-operating mode. The TxD time-out timer starts when the TLE7250 enters normal-operating mode and the TxD input is set to logical “low”.*

### 8.3.1 Mode Change while the TxD Signal is “low”

The example in [Figure 13](#) shows a mode change to normal-operating mode while the TxD input is logical “low”. The HS CAN signal is “recessive”, assuming all other HS CAN bus subscribers are also sending a “recessive” bus signal.

While the transceiver TLE7250 is in power-save mode, the transmitter and the normal-mode receiver are turned off. The TLE7250 drives no signal to the HS CAN bus nor does it receive any signal from the HS CAN bus. Changing the NEN to logical “low” turns the mode of operation to normal-operating mode, while the TxD input signal remains logical “low”. The transmitter and the normal-mode receiver remain disabled until the mode transition is completed. In normal-operating mode the transceiver and the normal-mode receiver are active. The “low” signal on the TxD input drives a “dominant” signal to the HS CAN bus and the RxD output pin becomes logical “low”, following the “dominant” signal on the HS CAN bus.

Changing the mode of operation from normal-operating mode to receive-only mode by setting the NRM input pin to “low”, disables the transmitter and the TxD input, but the normal-mode receiver and the RxD output remain active. The HS CAN bus becomes “recessive” since the transmitter is disabled. The RxD input indicates the “recessive” HS CAN bus signal by a logical “high” output signal (see also the example in [Figure 13](#)).

Mode changes between the power-save mode on the one side and the normal-operating mode or the receive-only mode on the other side, disable the transmitter and the normal-mode receiver. No signal can be driven to the HS CAN bus nor can it be received from the HS CAN bus. Mode changes between the normal-operating mode and the receive-only mode disable the transmitter and the normal mode receiver remains active. The HS CAN transceiver TLE7250 monitors the HS CAN bus also during the mode transition from normal-operating mode to receive-only mode and vice versa.

### 8.3.2 Mode Change while the Bus Signal is “dominant”

The example in [Figure 14](#) shows a mode change while the bus is “dominant” and the TxD input signal is set to logical “high”.

While the transceiver TLE7250 is in power-save mode, the transmitter and the normal-mode receiver are turned off. The TLE7250 drives no signal to the HS CAN bus nor does it receive any signal from the HS CAN bus. Changing the NEN to logical “low” turns the mode of operation to normal-operating mode, while the TxD input signal remains logical “high”. The transmitter and the normal-mode receiver remain disabled until the mode transition is completed. In normal-operating mode the transceiver and the receiver are active and therefore the RxD output changes to logical “low” indicating the “dominant” signal on the HS CAN bus.

Changing the mode of operation from normal-operating mode to receive-only mode by setting the NRM input pin to “low”, disables the transmitter and the TxD input, but the normal-mode receiver and the RxD output remain active. Since the “dominant” signal on the HS CAN bus is driven by another HS CAN bus subscriber, the bus remains “dominant” and the RxD input indicates the “dominant” HS CAN bus signal by a logical “low” output signal (see also the example in [Figure 14](#)).

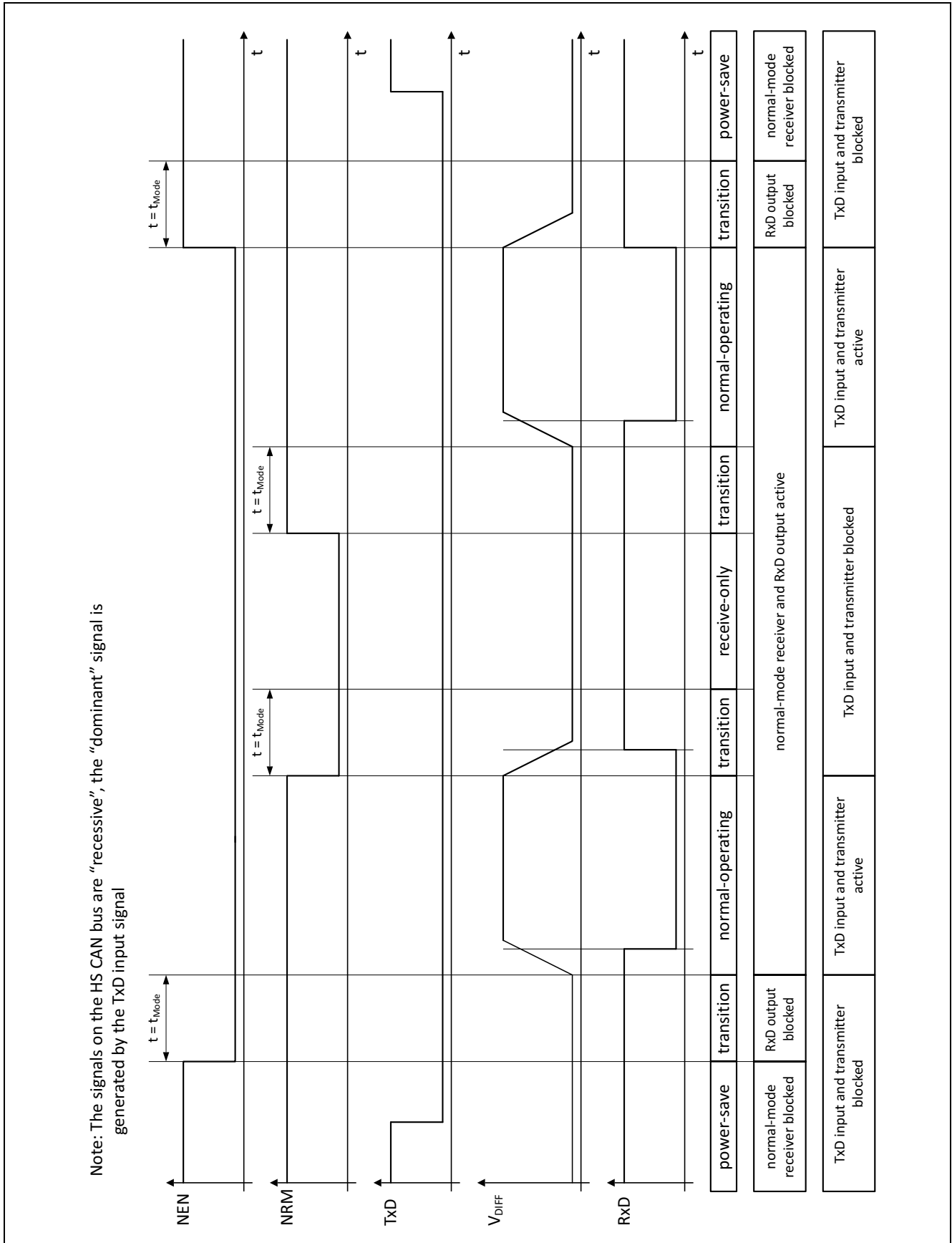

Figure 13 Example for a mode change while the TxD is “low”

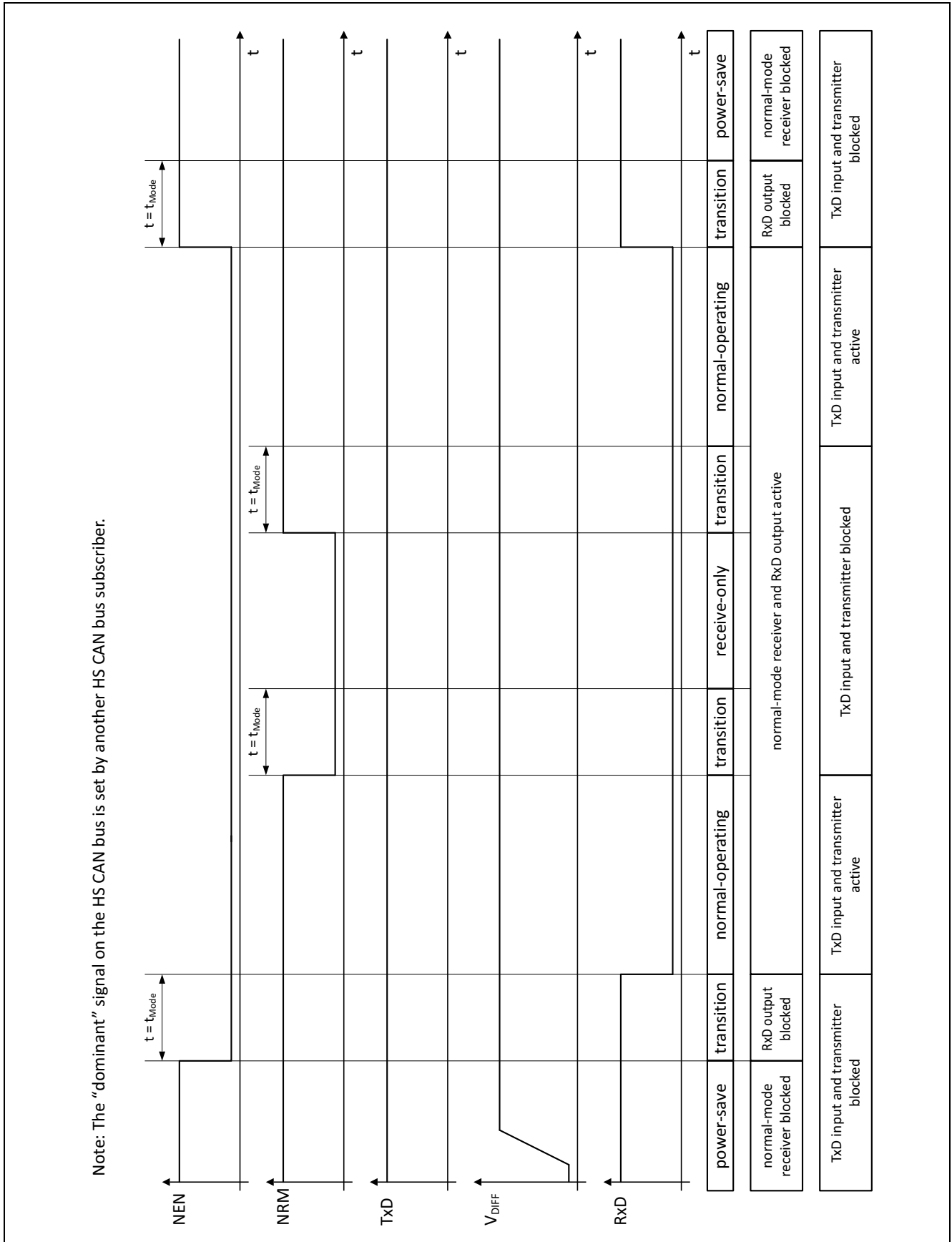

Figure 14 Example for a mode change while the HS CAN is “dominant”

## 8.4 Further Application Information

- Please contact us for information regarding the pin FMEA.
- Existing application note.
- For further information you may visit: <http://www.infineon.com/>



## 10 Revision History

| Revision | Date       | Changes             |
|----------|------------|---------------------|
| 1.00     | 2015-08-12 | Data Sheet created. |

**Edition 2015-08-12**

**Published by  
Infineon Technologies AG  
81726 Munich, Germany**

**© 2006 Infineon Technologies AG  
All Rights Reserved.**

### **Legal Disclaimer**

The information given in this document shall in no event be regarded as a guarantee of conditions or characteristics. With respect to any examples or hints given herein, any typical values stated herein and/or any information regarding the application of the device, Infineon Technologies hereby disclaims any and all warranties and liabilities of any kind, including without limitation, warranties of non-infringement of intellectual property rights of any third party.

### **Information**

For further information on technology, delivery terms and conditions and prices, please contact the nearest Infineon Technologies Office ([www.infineon.com](http://www.infineon.com)).

### **Warnings**

Due to technical requirements, components may contain dangerous substances. For information on the types in question, please contact the nearest Infineon Technologies Office.

Infineon Technologies components may be used in life-support devices or systems only with the express written approval of Infineon Technologies, if a failure of such components can reasonably be expected to cause the failure of that life-support device or system or to affect the safety or effectiveness of that device or system. Life support devices or systems are intended to be implanted in the human body or to support and/or maintain and sustain and/or protect human life. If they fail, it is reasonable to assume that the health of the user or other persons may be endangered.