

TLE9254

High speed dual CAN transceiver with bus wake-up



Features

- Compliant to ISO 11898-2:2016
- Dual channel CAN FD transceiver with very low quiescent current in stand-by mode
- Wide common mode range for electromagnetic immunity (EMI)
- Very low electromagnetic emission (EME) allows the use without additional common mode choke
- Excellent ESD robustness
- Very high CAN FD symmetry to support CAN FD data frames up to 5 MBit/s
- Extended supply range on V_{CC}
- CAN short circuit proof to ground, to battery and to V_{CC}
- TxD timeout function
- Low CAN bus leakage current in power-down state
- Overtemperature protection
- Protected against automotive transients according to ISO 7637 and SAE J2962-2
- Stand-by mode with bus wake-up pattern function
- Wake-up indication on the RxD output
- Green Product (RoHS compliant)

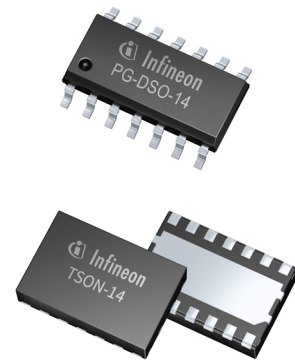

Potential applications

- Gateway modules
- Body Control Modules (BCMs)
- Electric Power Steering
- Battery Management Systems
- Cluster and Lighting Control Modules

Product validation

Qualified for automotive applications. Product validation according to AEC-Q100.

Description

The TLE9254 is part of Infineon's high speed CAN transceiver generation, used in HS CAN for automotive applications as well as in industrial applications. It is designed to fulfill the requirements of the following standards:

- ISO 11898-2 (2016) physical layer specification
- SAE J1939
- SAE J2284

TLE9254

High speed dual CAN transceiver with bus wake-up



Description

The TLE9254 is available in a PG-DSO-14 package and in a small, leadless PG-TSON-14 package. Both packages are RoHS compliant and halogen free. Additionally the PG-TSON-14 package supports the solder joint requirements for automated optical inspection (AOI).

As an interface between the physical bus layer and the HS CAN protocol controller, the TLE9254 is designed to protect the microcontroller against interference generated inside the network. A very high ESD robustness and the very high RF immunity allow the use in automotive applications without additional protection devices, such as suppressor diodes.

The very high transmitter symmetry combined with the optimized delay symmetry of the receiver enables the TLE9254 to support CAN FD data frames up to 5 Mbit/s. Based on the high symmetry of the CANH and CANL output signals, the TLE9254 provides a very low level of electromagnetic emission (EME) within a wide frequency range. The TLE9254 fulfills even stringent EMC test limits without external components, such as a common mode choke.

TLE9254 offers low-power management using the stand-by mode with an optimized, very low quiescent current. In stand-by mode the typical quiescent current for one channel of the TLE9254 is below 10 μ A, while the CAN channel can still wake up on a signal on the HS CAN bus.

Fail-safe features such as overtemperature protection, output current limitation or the TxD timeout feature are designed to protect the TLE9254 and the external circuitry from irreparable damage.

While the transceiver TLE9254 is not supplied, the bus is switched off and exhibits an ideal passive behavior with the lowest possible load to all other subscribers of the HS CAN network.

Type	Package	Marking
TLE9254SK	PG-DSO-14	9254
TLE9254LC	PG-TSON-14	9254

Table of contents

	Features	1
	Potential applications	1
	Product validation	1
	Description	1
	Table of contents	3
1	Block diagram	5
2	Pin configuration	6
2.1	Pin assignment	6
2.2	Pin definitions	6
3	General product characteristics	8
3.1	Absolute maximum ratings	8
3.2	Functional range	10
3.3	Thermal resistance	10
4	High speed CAN functional description	11
4.1	High speed CAN physical layer	11
5	Modes of operation	13
5.1	Normal-operating mode	14
5.2	Stand-by mode	15
5.3	Power-on reset	16
5.4	Bus Wake-up pattern (WUP) detection	17
5.4.1	Bus Wake-up pattern (WUP)	17
5.4.2	RxD pin wake-up behavior	17
6	Fail-safe functions	19
6.1	Short circuit protection	19
6.2	Unconnected logic pins	19
6.3	TxD timeout feature	19
6.4	Overtemperature protection	20
6.5	Undervoltage detection on V_{CC}	20
6.6	Delay time for mode change	21
7	Electrical characteristics	22
7.1	Electrical characteristics general timing parameters	22
7.2	Electrical characteristics power supply interface	22
7.2.1	Electrical characteristics current consumption	22
7.2.2	Electrical characteristics undervoltage detection	23
7.3	Electrical characteristics CAN controller interface	23
7.4	Electrical characteristics transmitter	24

Table of contents

7.5	Electrical characteristics receiver	26
7.6	Electrical characteristics dynamic transceiver parameters	27
7.7	Electrical characteristics wake-up pattern detection	31
8	Application information	32
8.1	ESD robustness according to IEC 61000-4-2	32
8.2	Application example	32
8.3	Further application information	33
9	Package information	34
	Revision history	36
	Disclaimer	37

Block diagram

1 Block diagram

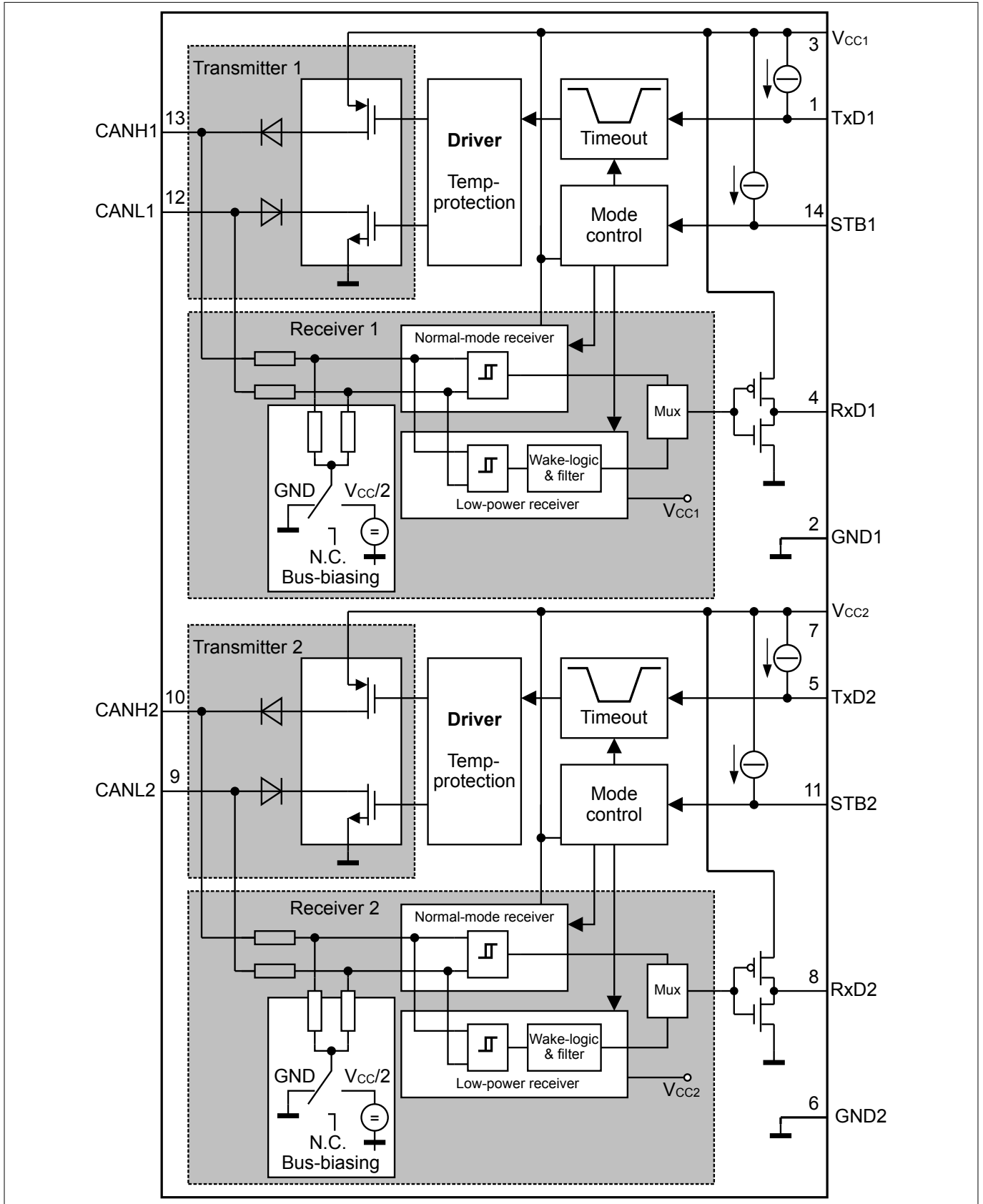

Figure 1 Block diagram

Pin configuration

2 Pin configuration

2.1 Pin assignment

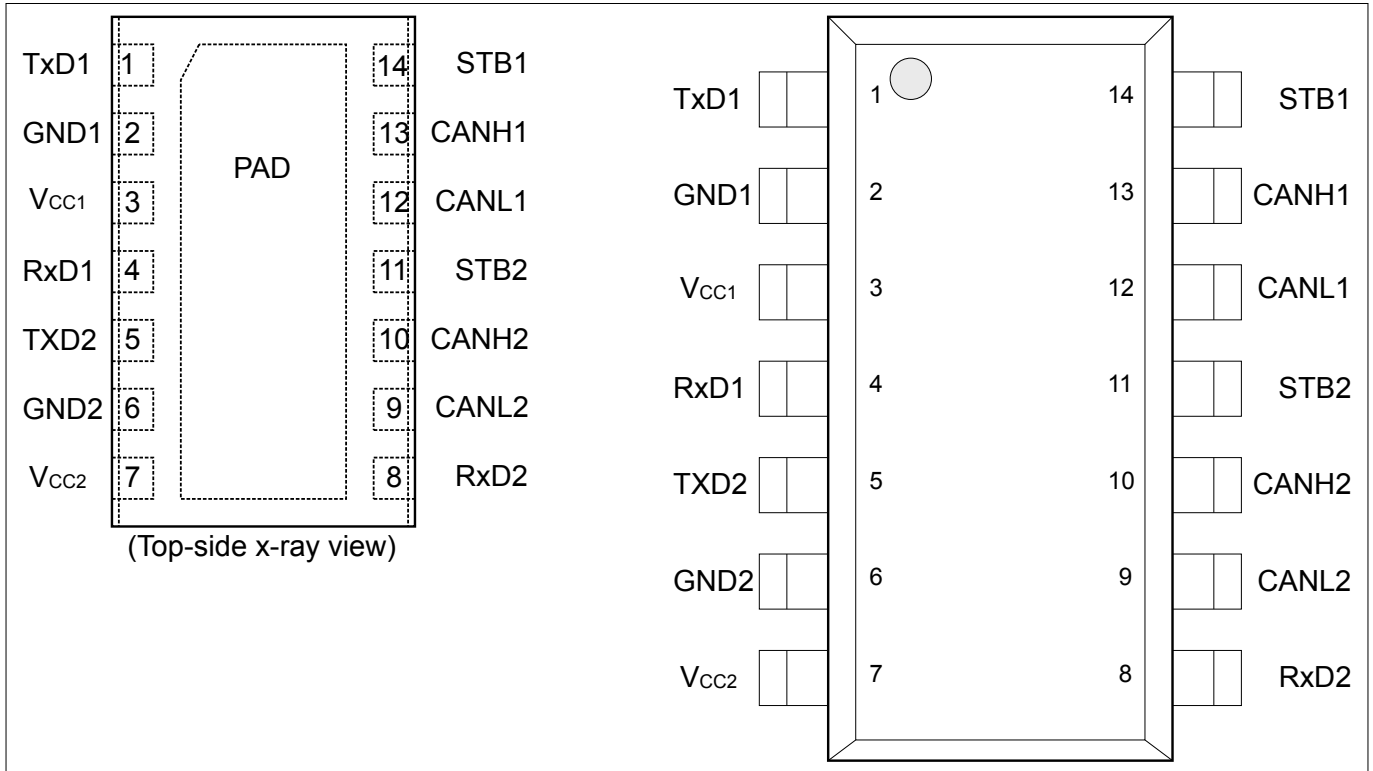

Figure 2 Pin configuration

2.2 Pin definitions

Table 1 Pin definitions and functions

Pin No.	Symbol	Function
1	TxD1	Transmit Data input for HS CAN channel 1; Internal pull-up current source to V_{CC} , "low" for dominant state.
2	GND1	Ground for HS CAN channel 1; GND1 and GND2 must be connected to the same ground of the PCB.
3	V_{CC1}	Transmitter supply voltage for HS CAN channel 1; 100 nF decoupling capacitor to GND required.
4	RxD1	Receive Data output for HS CAN channel 1; "low" in dominant state.
5	TxD2	Transmit Data input for HS CAN channel 2; Internal pull-up current source to V_{CC} , "low" for dominant state.
6	GND2	Ground for HS CAN channel 2;

Pin configuration

Table 1 Pin definitions and functions (continued)

Pin No.	Symbol	Function
		GND1 and GND2 must be connected to the same ground of the PCB.
7	V_{CC2}	Transmitter supply voltage for HS CAN channel 2; 100 nF decoupling capacitor to GND required.
8	RxD2	Receive Data output for HS CAN channel 2; "low" in dominant state.
9	CANL2	CAN bus Low level I/O for HS CAN channel 2; "low" in dominant state.
10	CANH2	CAN bus High level I/O for HS CAN channel 2; "high" in dominant state.
11	STB2	Stand-by control input for HS CAN channel 2; Internal pull-up current source to V_{CC} , "high" to select stand-by mode.
12	CANL1	CAN bus Low level I/O for HS CAN channel 1; "low" in dominant state.
13	CANH1	CAN bus High level I/O for HS CAN channel 1; "high" in dominant state.
14	STB1	Stand-by control input for HS CAN channel 1; Internal pull-up current source to V_{CC} , "high" to select stand-by mode.
PAD	–	Connect to PCB heat sink area. Do not connect to other potential than GND.

General product characteristics

3 General product characteristics

Electrical parameters described within this chapter apply for each channel of TLE9254, respectively.

3.1 Absolute maximum ratings

Table 2 Absolute maximum ratings voltages, currents and temperatures¹⁾

All voltages with respect to ground; positive current flowing into pin (unless otherwise specified)

Parameter	Symbol	Values			Unit	Note or condition	Number
		Min.	Typ.	Max.			
Voltages							
Transmitter supply voltage	V_{CC}	-0.3	–	6.0	V	–	P_7.1.1
CANH DC voltage versus GND	V_{CANH}	-40	–	40	V	–	P_7.1.2
CANL DC voltage versus GND	V_{CANL}	-40	–	40	V	–	P_7.1.14
Differential voltage between CANH and CANL	V_{CAN_Diff}	-40	–	40	V	–	P_7.1.3
Voltages at pins: STB, TxD, RxD	V_{MAX_IO1}	-0.3	–	6	V	–	P_7.1.4
Voltages at pin: STB, TxD, RxD	V_{MAX_IO2}	-0.3	–	$V_{CC} + 0.3$	V	–	P_7.1.5
Currents							
RxD output current	I_{RxD}	-20	–	20	mA	–	P_7.1.6
Temperatures							
Junction temperature	T_j	-40	–	150	°C	–	P_7.1.7
Storage temperature	T_S	-55	–	150	°C	–	P_7.1.8
ESD resistivity							
ESD immunity at CANH, CANL versus GND	$V_{ESD_HBM_CAN}$	-10	–	10	kV	²⁾ HBM (100 pF via 1.5 kΩ)	P_7.1.10
ESD immunity at all other pins	$V_{ESD_HBM_ALL}$	-3	–	3	kV	²⁾ HBM (100 pF via 1.5 kΩ)	P_7.1.11
ESD immunity at corner pins	$V_{ESD_CDM_CP}$	-750	–	750	V	³⁾ CDM	P_7.1.12
ESD immunity at any pin	$V_{ESD_CDM_OP}$	-500	–	500	V	³⁾ CDM	P_7.1.13

Notes:

- 1 Not subject to production test, specified by design.
- 2 ESD susceptibility, Human Body Model (HBM) according to ANSI/ESDA/JEDEC JS-001.
- 3 ESD susceptibility, Charged Device Model (CDM) according to EIA/JESD22-C101 or ESDA STM5.3.1.

General product characteristics

1. *Stresses above the ones listed here may cause permanent damage to the device. Exposure to absolute maximum rating conditions for extended periods of time may affect device reliability.*
2. *Integrated protection functions are designed to prevent IC destruction under fault conditions described in the data sheet. Fault conditions are considered as outside the normal operating range. Protection functions are not designed for continuous repetitive operation.*

General product characteristics

3.2 Functional range

Table 3 Functional range

Parameter	Symbol	Values			Unit	Note or condition	Number
		Min.	Typ.	Max.			

Supply voltages

Transmitter supply voltage	V_{CC}	4.5	–	5.5	V	–	P_7.2.1
----------------------------	----------	-----	---	-----	---	---	---------

Thermal parameters

Junction temperature	T_j	-40	–	150	°C	–	P_7.2.2
----------------------	-------	-----	---	-----	----	---	---------

Note: Within the functional or operating range, the IC operates as described in the circuit description. The electrical characteristics are specified within the conditions given in the electrical characteristics table.

3.3 Thermal resistance

Note: This thermal data was generated in accordance with JEDEC JESD51 standards. For more information visit www.jedec.org.

Table 4 Thermal resistance⁴⁾

Parameter	Symbol	Values			Unit	Note or condition	Number
		Min.	Typ.	Max.			

Thermal resistance

Junction to ambient PG-TSON-14	R_{thJA_TSON14}	–	65	–	K/W	⁵⁾	P_7.3.1
Junction to ambient PG-DSO-14	R_{thJA_DSO14}	–	120	–	K/W	⁵⁾	P_7.3.2

Thermal shutdown (junction temperature)

Thermal shutdown temperature	T_{JSD}	170	180	190	°C	–	P_7.3.3
Thermal shutdown hysteresis	ΔT	5	8	20	K	–	P_7.3.4

⁴ Not subject to production test, specified by design.

⁵ Specified R_{thJA} value is according to JEDEC JESD51-2,-7 at natural convection on FR4 2s2p board; the product (chip and package) was simulated on a 76.2 × 114.3 × 1.5 mm³ board with two inner copper layers (2 × 70 μm Cu, 2 × 35 μm Cu).

High speed CAN functional description

4 High speed CAN functional description

HS CAN is a serial bus system that connects microcontrollers, sensors and actuators for real-time control applications. ISO 11898 describes the use of the Controller Area Network (CAN) within road vehicles. According to the 7-layer OSI reference model, the physical layer of an HS CAN bus system specifies the data transmission from one CAN node to all other available CAN nodes within the network. The physical layer specification of a CAN bus system includes all electrical specifications of a CAN network. The CAN transceiver is part of the physical layer specification. The TLE9254 is a high speed CAN transceiver with a dedicated bus wake-up function as defined in the latest ISO 11898-2 HS CAN standard.

4.1 High speed CAN physical layer

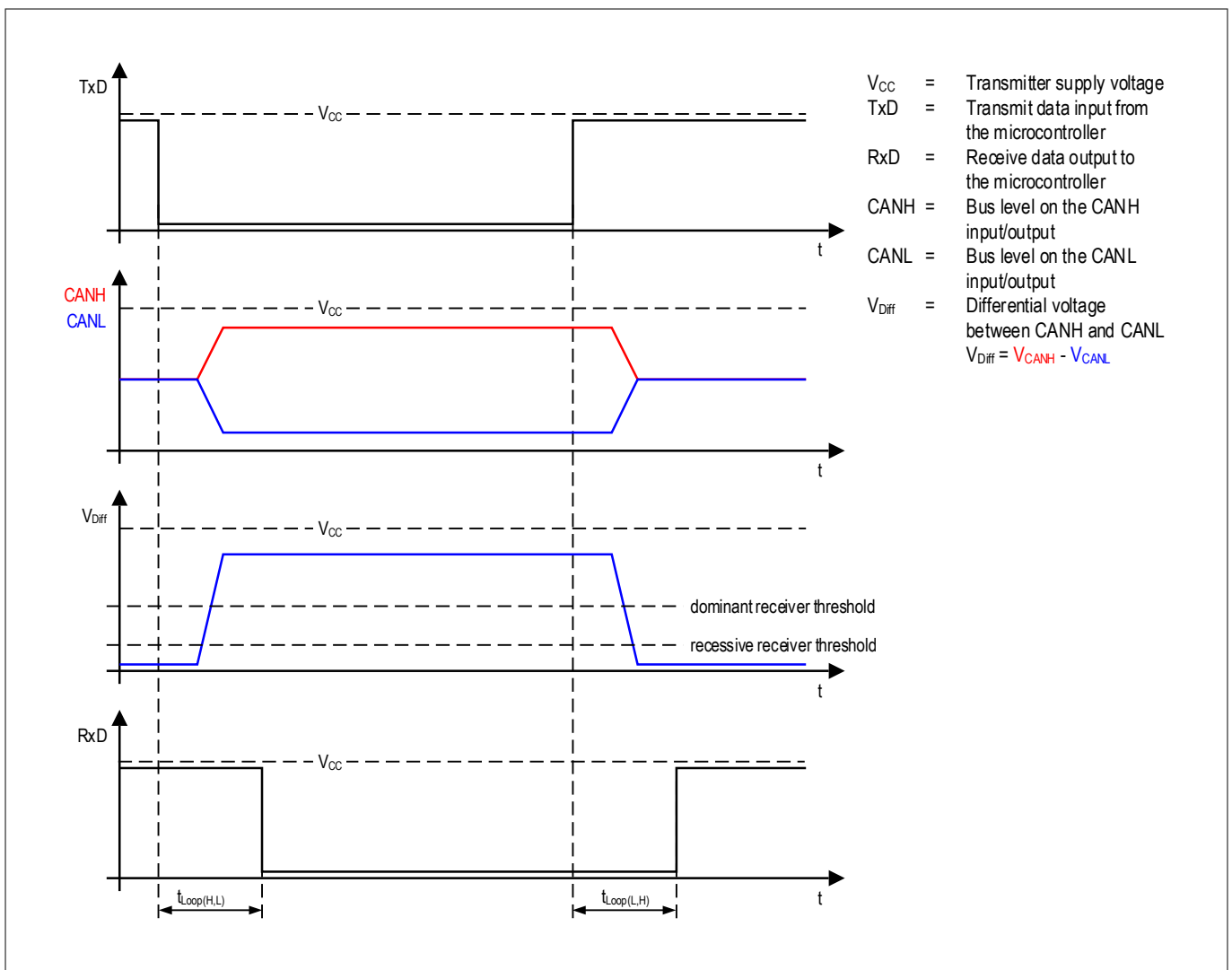

Figure 3 High speed CAN bus signals and logic signals

High speed CAN functional description

The TLE9254 is a high speed CAN transceiver, operating as an interface between the CAN controller and the physical bus medium. An HS CAN network is a two wire, differential network which allows data transmission rates up to 5 MBit/s. HS CAN signals can have the following states on the CAN bus: dominant and recessive (see [Figure 3](#)).

The CANH and CANL pins are the interface to the CAN bus and both pins operate as input and output simultaneously. The RxD and TxD pins are the interface to the microcontroller. The TxD pin is the serial data input from the CAN controller, the RxD pin is the serial data output to the CAN controller. The TLE9254 includes a receiver and a transmitter unit, allowing the transceiver to send data to the bus medium and monitor the data from the bus medium at the same time, see [Figure 1](#). The TLE9254 converts the serial data stream, which is available on the transmit data input TxD, into a differential output signal on the CAN bus, provided by the CANH and CANL pins. The receiver stage of the TLE9254 monitors the data on the CAN bus and converts them to a serial, single-ended signal on the RxD output pin. A "low" signal on the TxD pin creates a dominant signal on the CAN bus, followed by a logical "low" signal on the RxD pin (see [Figure 3](#)). The feature of broadcasting data to the CAN bus and listening to the data traffic on the CAN bus simultaneously is essential to support the bit-to-bit arbitration within CAN.

ISO 11898-2 specifies the voltage levels for HS CAN transceivers. Whether a data bit is dominant or recessive depends on the voltage difference between the CANH and CANL pins:

$$V_{\text{Diff}} = V_{\text{CANH}} - V_{\text{CANL}}$$

To transmit a dominant signal to the CAN bus, the amplitude of the differential signal V_{Diff} is higher than or equal to 1.5 V. To receive a recessive signal from the CAN bus, the amplitude of the differential V_{Diff} is lower than or equal to 0.5 V.

In partially-supplied high speed CAN the bus nodes of one common network have different power supply conditions. Some nodes are connected to the common power supply, while other nodes are disconnected from the power supply and in power-down state. Regardless of whether the CAN bus subscriber is supplied or not, each subscriber connected to the common bus media must not interfere with the communication. The TLE9254 is designed to support partially-supplied networks. In power-down state, the receiver input resistors are switched off and the transceiver input has a high resistance.

For permanently supplied ECUs, the TLE9254 provides a stand-by mode. In stand-by mode, the power consumption of the TLE9254 is optimized to a minimum.

The voltage level on the digital input TxD and the digital output RxD is determined by the power supply level at the V_{CC} pin.

Modes of operation

5 Modes of operation

The description within this chapter applies for each of the two HS CAN channels of TLE9254. The HS CAN channels are independent from each other. Both HS CAN channels have equal functionality.

The TLE9254 supports two different modes of operation for each HS CAN channel (see **Figure 4**):

- Normal-operating mode (see **Normal-operating mode**)
- Stand-by mode (see **Stand-by mode**)

The mode selection input pin STB triggers mode changes. If a wake-up event occurs on the HS CAN bus, then the TLE9254 indicates that on the RxD output pin in stand-by mode, but it does not trigger a mode change. The transceiver channels work independently from each other. Channel 1 is supplied by V_{CC1} and STB1 selects the mode of operation. channel 2 is supplied by V_{CC2} and STB2 selects the mode of operation.

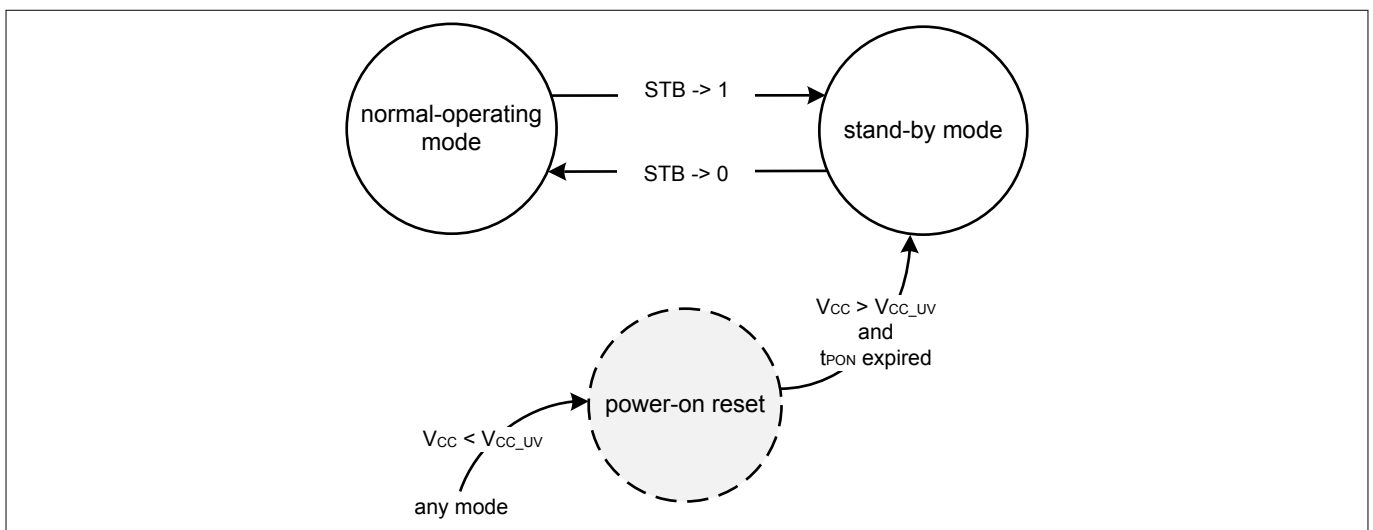

Figure 4 Mode state diagram

Modes of operation

5.1 Normal-operating mode

In normal-operating mode the TLE9254 sends and receives data from the HS CAN bus. All functions are active (see [Figure 4](#)):

- The transmitter is enabled and drives the serial data stream on the TxD input pin to the bus pins CANH and CANL.
- The receiver is enabled and converts the signal from the bus to a serial data stream on the RxD output pin.
- The bus biasing is connected to $V_{CC}/2$.
- The STB input pin drives the mode of operation and can change the mode of operation.
- The TxD timeout function is enabled (see [TxD timeout feature](#)).
- The overtemperature protection is enabled (see [Overtemperature protection](#)).
- The undervoltage detection on V_{CC} is enabled (see [Undervoltage detection on \$V_{CC}\$](#)).

Conditions for entering the normal-operation mode for one channel of TLE9254:

- One channel of TLE9254 enters normal-operating mode after t_{Mode} , by setting the respective mode selection pin STB to "low" (see [Figure 4](#)).

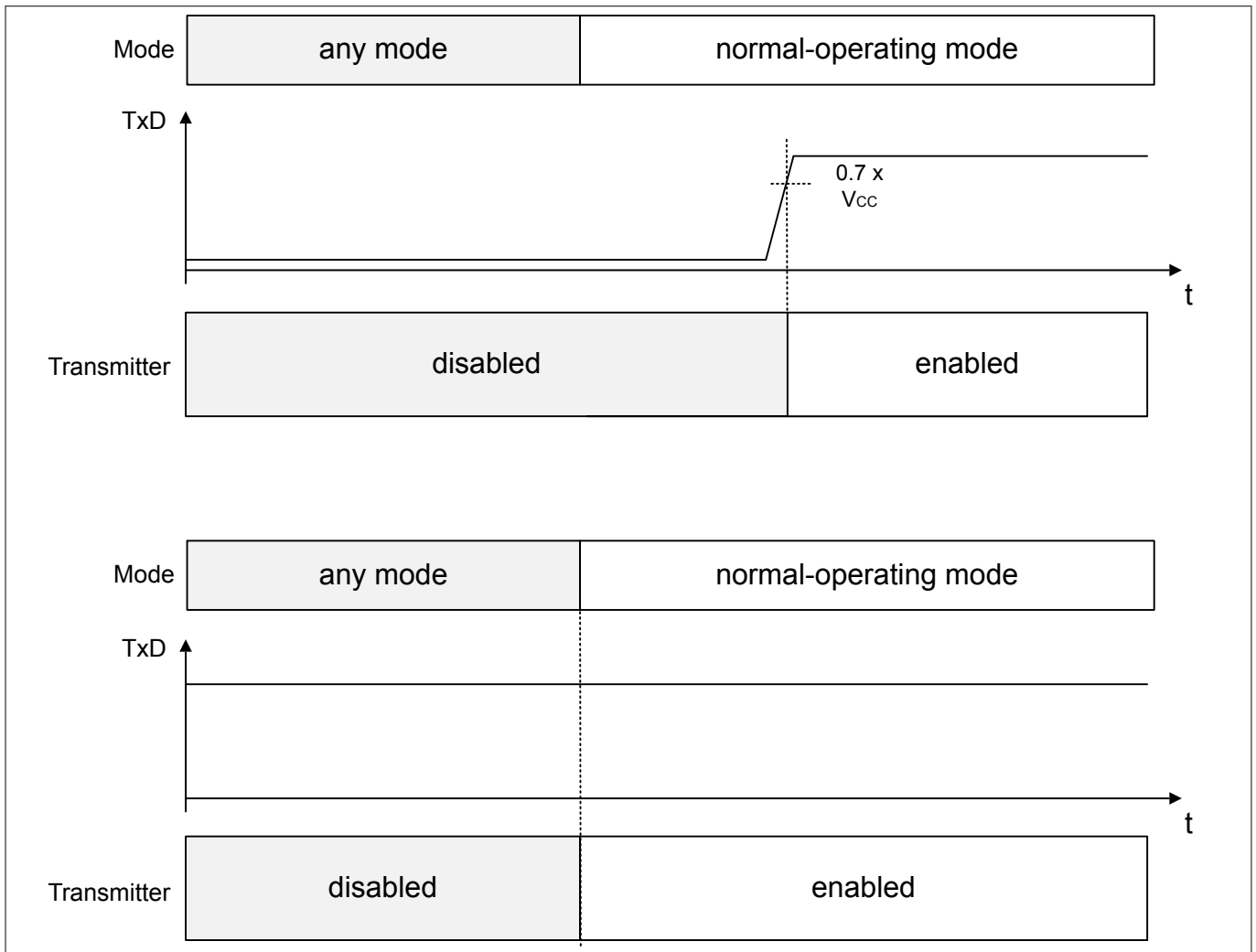

Figure 5 Mode change to normal-operating mode with dominant signal on TxD

If a recessive signal on TxD input pin is applied after a mode change from any mode to normal-operating mode, then the TLE9254 enables the transmitter path. If a dominant signal is on TxD input pin after a mode change, then the TLE9254 keeps the transmitter path disabled and blocks the dominant signal in order not to disturb the bus communication (see [Figure 5](#)).

Modes of operation

5.2 Stand-by mode

The stand-by mode is the low-power mode of the TLE9254. In stand-by mode most of the functions are disabled and each channel of TLE9254 monitors the respective bus for a valid wake-up pattern (WUP), see [Bus Wake-up pattern \(WUP\) detection](#). The following functions are available in stand-by mode:

- The transmitter is disabled and the data available on the TxD input is blocked.
- The TLE9254 monitors the bus for a valid wake-up pattern (WUP).
- The RxD output pin indicates a wake-up (see [RxD pin wake-up behavior](#)).
- The bus biasing is connected to GND.
- The TxD timeout function is disabled.
- The overtemperature protection is disabled.
- The undervoltage detection on V_{CC} is enabled (see [Undervoltage detection on \$V_{CC}\$](#)).

Conditions for entering the stand-by mode for one channel of TLE9254:

- If $V_{CC} > V_{CC_UV}$ for at least t_{PON} after power-on reset, then the TLE9254 enters stand-by mode.
- If STB is set to "high" in normal-operating mode, then the TLE9254 enters stand-by mode.

Modes of operation

5.3 Power-on reset

In power-on reset the CANH and CANL bus interface of the TLE9254 acts as a high-impedance input with a very low leakage current. The highly-resistive input does not influence the recessive level of the CAN network and allows an optimized EME performance of the entire HS CAN.

In power-on reset all functions of the TLE9254 are disabled and all channels are switched off:

- The transmitter and receiver are disabled.
- The bus biasing is connected to high impedance.
- The TxD timeout function is disabled.
- The overtemperature protection is disabled.
- The undervoltage detection on V_{CC} is disabled.
- The logical input pins are blocked.
- RxD is connected to high impedance.

Conditions for entering the power-on reset:

- V_{CC} is below the V_{CC_UV} threshold (see [Figure 6](#)).

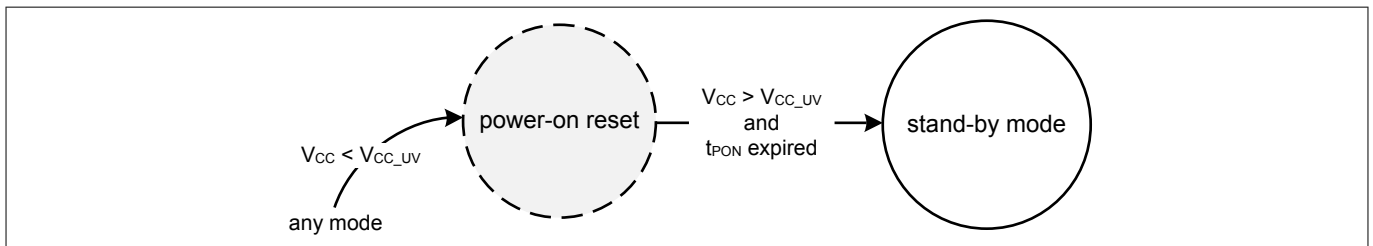

Figure 6 Power-up and power-down timings

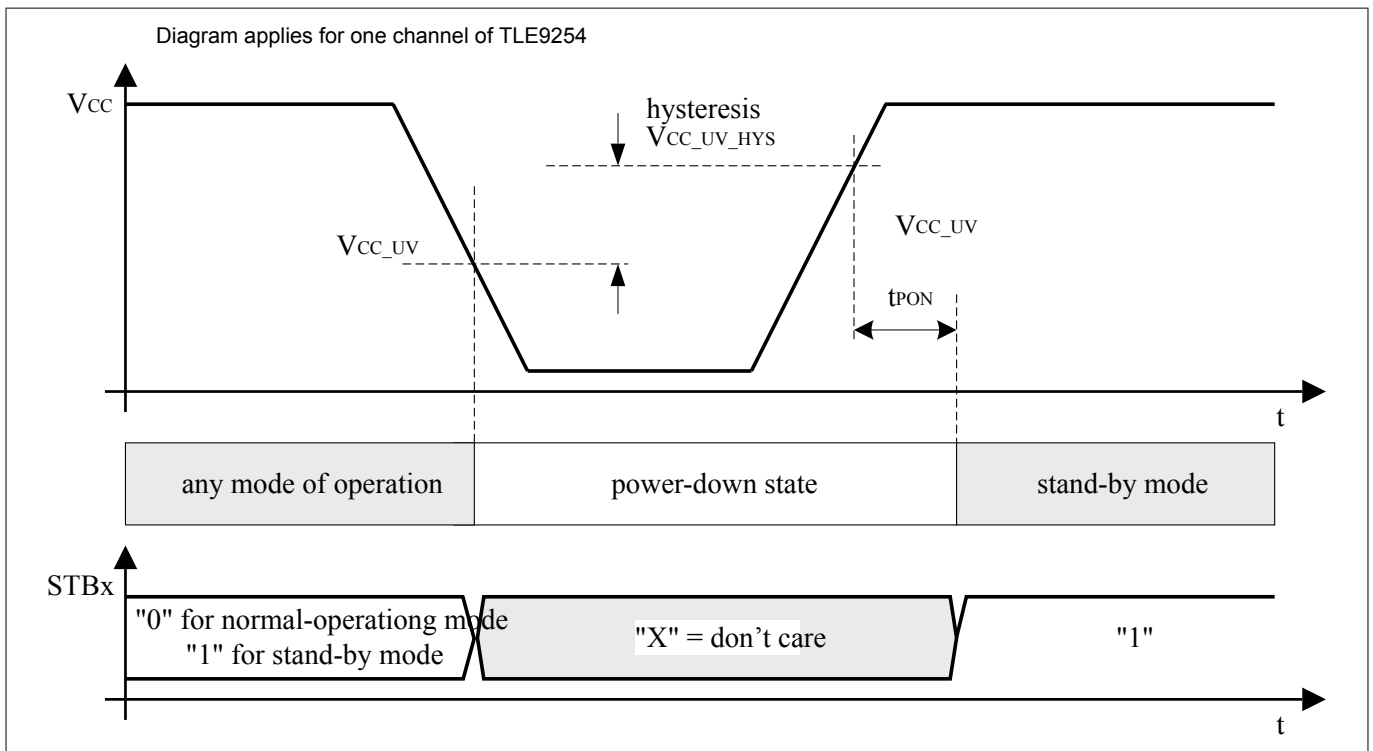

Figure 7 Power-up and power-down timings

Modes of operation

5.4 Bus Wake-up pattern (WUP) detection

Each channel of TLE9254 has a separate remote wake-up feature called bus wake-up feature according to ISO 11898-2:2016. In stand-by mode the low-power receiver monitors the activity on the CAN bus. If it detects a wake-up pattern, then the device indicates the wake-up signal on the RxD output pin of the dedicated channel. A wake-up event does not trigger a mode change of the respective channel. The TLE9254 remains in stand-by mode until the microcontroller requests a mode change to normal-operating mode. A valid wake-up pattern triggers a wake-up of the dedicated bus.

5.4.1 Bus Wake-up pattern (WUP)

The wake-up pattern contains the following sequence of signals:

- dominant with pulse width $> t_{Filter}$
- recessive with pulse width $> t_{Filter}$
- dominant with pulse width $> t_{Filter}$

The t_{Wake} starts with the first valid dominant pulse (pulse width $> t_{Filter}$). The subsequent recessive and dominant pulses must occur within t_{Wake} to fulfill a wake-up pattern, see [Figure 8](#). As long as the TLE9254 does not detect a wake-up event, the RxD output remains "high".

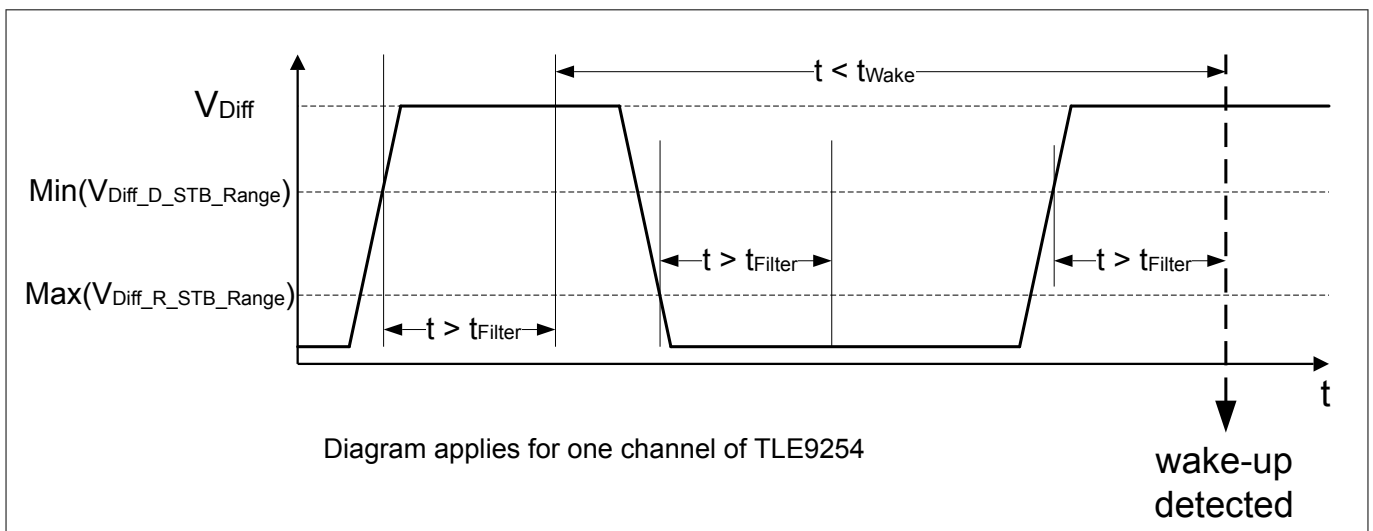

Figure 8 Remote wake-up signal

5.4.2 RxD pin wake-up behavior

If TLE9254 detects a wake-up event, then it sets the RxD output to "low" (see [Figure 9](#)).

Modes of operation

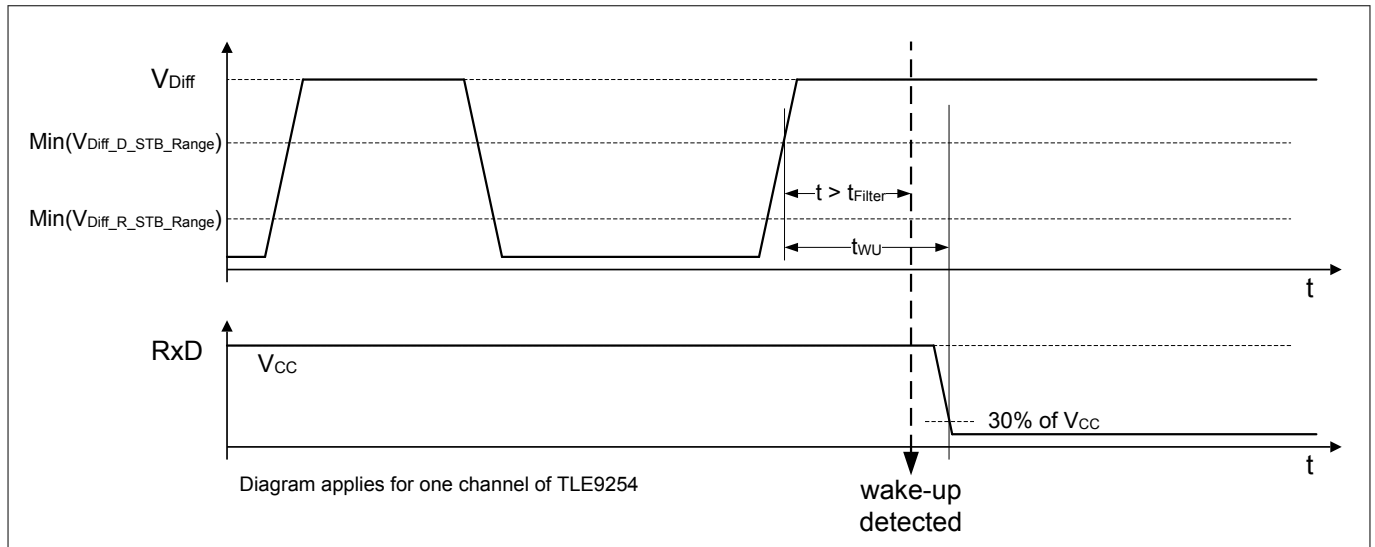

Figure 9 RxD signal after wake-up detection

The TLE9254 disables the RxD pin wake-up behavior under each of the following conditions:

- A mode change to normal-operating mode is applied during the wake-up pattern.
- A power-down event occurs on the voltage supply $V_{CC} < V_{CC_uv}$.

Fail-safe functions

6 Fail-safe functions

6.1 Short circuit protection

The CANH and CANL bus outputs are short circuit proof to GND and short circuit proof to a positive supply voltage. A current limiting circuit is designed to protect the transceiver against damage.

6.2 Unconnected logic pins

If the input pins are not connected and floating, then this forces the TLE9254 into fail-safe behavior (see [Table 5](#)).

Table 5 Logical inputs when unconnected

Input signal	Default state	Comment
TxD	"high"	pull-up current source to V_{CC}
STB	"high"	pull-up current source to V_{CC}

6.3 TxD timeout feature

The TxD timeout feature protects the CAN bus from permanently blocking in case the logical signal on the TxD pin is continuously "low". A continuous "low" signal on the TxD pin might have its root cause in a locked-up microcontroller or in a short circuit on the printed circuit board, for example. In normal-operating mode, a logical "low" signal on the TxD pin for the time $t > t_{TxD_TO}$ enables the TxD timeout feature and the TLE9254 disables the transmitter (see [Figure 10](#)). The receiver is still active. It monitors the CAN bus communication on the CANH and CANL pins and reflects it on the RxD pin. The TxD timeout feature works for each CAN channel independently.

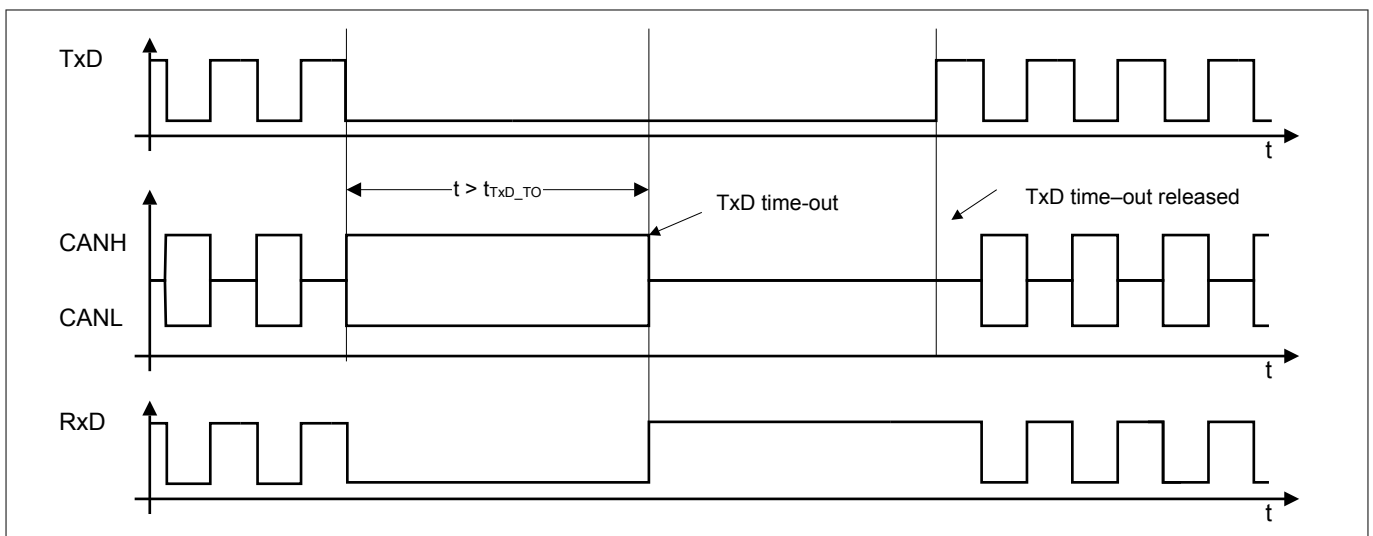

Figure 10 TxD timeout function

[Figure 10](#) shows how the transmitter is disabled and enabled again. A permanent "low" signal on the TxD input pin activates the TxD timeout function and disables the transmitter. To release the transmitter after a TxD timeout event, the TLE9254 requires a signal change from "low" to "high" on the TxD input pin.

Fail-safe functions

6.4 Overtemperature protection

The integrated overtemperature detection is designed to protect the TLE9254 from thermal overstress of the transmitter. If the temperature exceeds the threshold T_{JSD} , then the TLE9254 disables the transmitter. After the device cools down, the TLE9254 enables the transmitter again (see [Figure 11](#)). A hysteresis is implemented within the temperature sensor.

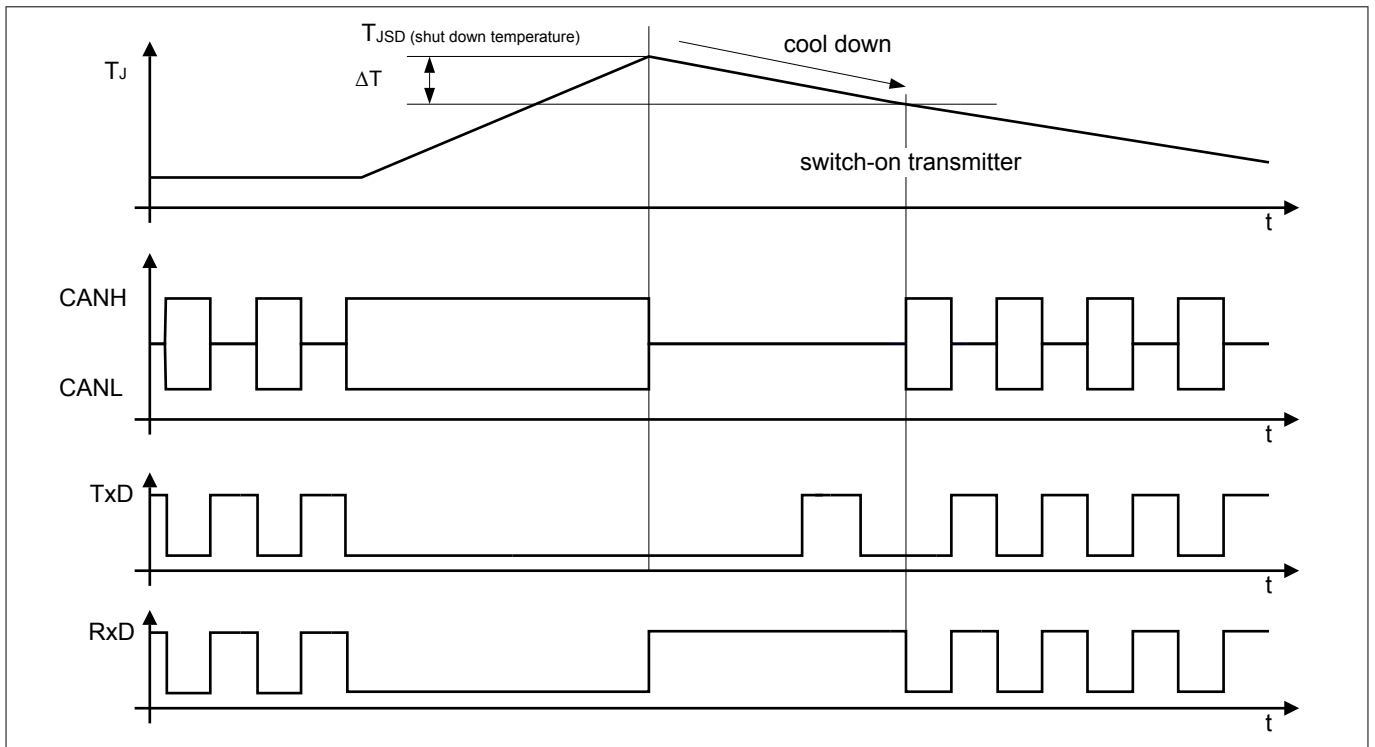

Figure 11 Overtemperature protection

6.5 Undervoltage detection on V_{CC}

If $V_{CC} < V_{CC_UV}$, then the affected channel reacts as described in [Power-on reset](#) (see [Power-on reset](#)). If V_{CC} has recovered ($V_{CC} > V_{CC_UV}$) and t_{PON} time has expired, then The TLE9254 enters the normal-operating mode (transmitter is enabled) or stand-by mode, depending on the STB pin.

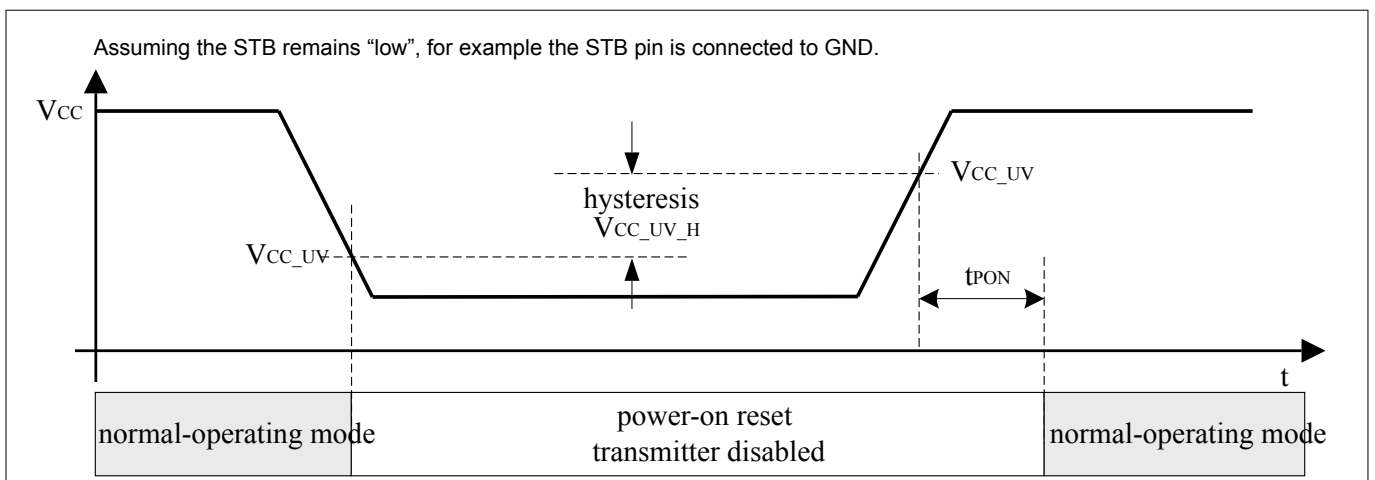

Figure 12 V_{CC} undervoltage

6.6 Delay time for mode change

The HS CAN transceiver TLE9254 changes the mode of operation within the time window t_{Mode} . During the mode change the TLE9254 sets the RxD output pin permanently to "high", so RxD does not reflect the status on the CANH and CANL input pins then. After the mode change is completed, the TLE9254 releases the RxD output pin.

Electrical characteristics

7 Electrical characteristics

Electrical parameters described within this chapter apply for each channel of TLE9254.

7.1 Electrical characteristics general timing parameters

Table 6 Electrical characteristics general timing parameters

$V_{CC} = 4.5\text{ V to }5.5\text{ V}$; $R_L = 60\ \Omega$; $T_j = -40^\circ\text{C to }150^\circ\text{C}$;

all voltages with respect to ground, positive current flowing into pin (unless otherwise specified)

Parameter	Symbol	Values			Unit	Note or condition	Number
		Min.	Typ.	Max.			
Power up delay time	t_{PON}	–	–	110	μs	–	P_8.1.2
Delay time for mode change	t_{Mode}	–	–	20	μs	–	P_8.1.3
TxD permanent dominant timeout	t_{TxD_TO}	1	–	4	ms	Normal-operating mode, see TxD timeout feature	P_8.1.4

7.2 Electrical characteristics power supply interface

7.2.1 Electrical characteristics current consumption

Table 7 Electrical characteristics current consumption

$V_{CC} = 4.5\text{ V to }5.5\text{ V}$; $R_L = 60\ \Omega$; $T_j = -40^\circ\text{C to }150^\circ\text{C}$;

all voltages with respect to ground, positive current flowing into pin (unless otherwise specified)

Parameter	Symbol	Values			Unit	Note or condition	Number
		Min.	Typ.	Max.			
Normal-operating mode							
V_{CC} supply current dominant bus signal	$I_{CC_NM_D}$	–	33	48	mA	dominant state, $V_{TxD} = V_{STB} = 0\text{ V}$ ⁶⁾	P_8.2.1
V_{CC} supply current recessive bus signal	$I_{CC_NM_R}$	–	2.0	2.5	mA	recessive state, $V_{TxD} = V_{CC}$ $V_{STB} = 0\text{ V}$ ⁶⁾	P_8.2.2
Stand-by Mode							
V_{CC} supply current (both transceivers together)	I_{CC_STB}	–	16	32	μA	$V_{TxD} = V_{CC}$	P_8.2.4

⁶⁾ Applies for one channel of TLE9254.

Electrical characteristics

Table 7 Electrical characteristics current consumption (continued)

$V_{CC} = 4.5\text{ V to }5.5\text{ V}$; $R_L = 60\ \Omega$; $T_j = -40^\circ\text{C to }150^\circ\text{C}$;

all voltages with respect to ground, positive current flowing into pin (unless otherwise specified)

Parameter	Symbol	Values			Unit	Note or condition	Number
		Min.	Typ.	Max.			
V_{CC} supply current (both transceivers together)	I_{CC_STB}	–	10	22	μA	$V_{\text{TxD}} = V_{CC}$, $T_j < 105^\circ\text{C}$ ⁷⁾	P_8.2.5

7.2.2 Electrical characteristics undervoltage detection

Table 8 Electrical characteristics undervoltage detection

$V_{CC} = 4.5\text{ V to }5.5\text{ V}$; $R_L = 60\ \Omega$; $T_j = -40^\circ\text{C to }150^\circ\text{C}$;

all voltages with respect to ground, positive current flowing into pin (unless otherwise specified)

Parameter	Symbol	Values			Unit	Note or condition	Number
		Min.	Typ.	Max.			
Undervoltage detection							
Undervoltage detection threshold	V_{CC_UV}	3.8	4.25	4.5	V	–	P_8.2.9

7.3 Electrical characteristics CAN controller interface

Table 9 Electrical characteristics CAN controller interface

$V_{CC} = 4.5\text{ V to }5.5\text{ V}$; $R_L = 60\ \Omega$; $T_j = -40^\circ\text{C to }150^\circ\text{C}$;

all voltages with respect to ground, positive current flowing into pin (unless otherwise specified)

Parameter	Symbol	Values			Unit	Note or condition	Number
		Min.	Typ.	Max.			
Input pins: STB, TxD							
"High" level input range	V_{IP_H}	$0.7 \times V_{CC}$	–	$V_{CC} + 0.3\text{V}$	V	–	P_8.3.1
"Low" level input range	V_{IP_L}	-0.3V	–	$0.3 \times V_{CC}$	V	–	P_8.3.2
"High" level input current	I_{IP_H}	-2.0	–	2.0	μA	$V_{IP} = V_{CC}$	P_8.3.3
"Low" level input current	I_{IP_L}	-200	–	-20.0	μA	$V_{IP} = 0\text{ V}$	P_8.3.4
Input capacitance	C_{IP}	–	–	10	pF	⁸⁾	P_8.3.7

⁷ Not subject to production test, specified by design.

⁸ Not subject to production test, specified by design.

Electrical characteristics

Table 9 Electrical characteristics CAN controller interface (continued)

$V_{CC} = 4.5\text{ V to }5.5\text{ V}$; $R_L = 60\ \Omega$; $T_j = -40^\circ\text{C to }150^\circ\text{C}$;

all voltages with respect to ground, positive current flowing into pin (unless otherwise specified)

Parameter	Symbol	Values			Unit	Note or condition	Number
		Min.	Typ.	Max.			
Receiver output RxD							
"High" level output current	I_{RxD_H}	–	-1.8	-1.0	mA	$V_{\text{RxD}} = V_{CC} - 0.4\text{ V}$ $V_{\text{DIFF}} < 0.5\text{ V}$	P_8.3.8
"Low" level output current	I_{RxD_L}	1.0	2.0	–	mA	$V_{\text{RxD}} = 0.4\text{ V}$ $V_{\text{DIFF}} > 0.9\text{ V}$	P_8.3.9

7.4 Electrical characteristics transmitter

Table 10 Electrical characteristics transmitter

$V_{CC} = 4.5\text{ V to }5.5\text{ V}$; $R_L = 60\ \Omega$; $T_j = -40^\circ\text{C to }150^\circ\text{C}$;

all voltages with respect to ground, positive current flowing into pin (unless otherwise specified)

Parameter	Symbol	Values			Unit	Note or condition	Number
		Min.	Typ.	Max.			
Bus transmitter							
CANH, CANL recessive output voltage	$V_{\text{CANL}/H}$	2.0	2.4	3.0	V	Normal-operating mode, $V_{\text{TXD}} = V_{CC}$ no load	P_8.4.1
CANH, CANL recessive output voltage difference	$V_{\text{Diff}_R_{NM}} = V_{\text{CANH}} - V_{\text{CANL}}$	-50	–	50	mV	$V_{\text{TXD}} = V_{CC}$ no load	P_8.4.2
CANH dominant output voltage normal-operating mode	V_{CANH}	2.75	–	4.5	V	$V_{\text{TXD}} = 0\text{ V}$, $50\ \Omega < R_L < 65\ \Omega$; $4.75\text{ V} < V_{CC} < 5.25\text{ V}$	P_8.4.3
CANL dominant output voltage normal-operating mode	V_{CANL}	0.5	–	2.25	V	$V_{\text{TXD}} = 0\text{ V}$, $50\ \Omega < R_L < 65\ \Omega$; $4.75\text{ V} < V_{CC} < 5.25\text{ V}$	P_8.4.4
CANH dominant output voltage difference: $V_{\text{Diff}_D} = V_{\text{CANH}} - V_{\text{CANL}}$ normal-operating mode	V_{Diff_D}	1.5	1.8	2.5	V	$V_{\text{TXD}} = 0\text{ V}$, $50\ \Omega < R_L < 65\ \Omega$; $4.75\text{ V} < V_{CC} < 5.25\text{ V}$	P_8.4.5

Electrical characteristics

Table 10 Electrical characteristics transmitter (continued)

$V_{CC} = 4.5\text{ V to }5.5\text{ V}$; $R_L = 60\ \Omega$; $T_j = -40^\circ\text{C to }150^\circ\text{C}$;

all voltages with respect to ground, positive current flowing into pin (unless otherwise specified)

Parameter	Symbol	Values			Unit	Note or condition	Number
		Min.	Typ.	Max.			
CANH dominant output voltage difference extended bus load $V_{\text{Diff}_D} = V_{\text{CANH}} - V_{\text{CANL}}$ normal-operating mode	$V_{\text{Diff}_D_EXT_BL}$	1.4	–	3.3	V	$V_{\text{TxD}} = 0\text{ V}$, $R_L = 45\ \Omega < R_L < 70\ \Omega$; $4.75\text{ V} < V_{CC} < 5.25\text{ V}$	P_8.4.6
CANH, CANL dominant output voltage difference high extended bus load normal-operating mode $V_{\text{Diff}} = V_{\text{CANH}} - V_{\text{CANL}}$	$V_{\text{Diff}_D_HEXT_BL}$	1.5	–	5.0	V	⁹⁾ $V_{\text{TxD}} = 0\text{ V}$, $R_L = 2240\ \Omega$; $4.75\text{ V} < V_{CC} < 5.25\text{ V}$; static behavior	P_8.4.7
CANH, CANL recessive output voltage stand-by mode	V_{CANL_H}	-0.1	–	0.1	V	no load	P_8.4.8
CANH, CANL recessive output voltage difference stand-by mode	V_{Diff_STB}	-0.2	–	0.2	V	no load	P_8.4.9
Driver symmetry $V_{\text{SYM}} = V_{\text{CANH}} + V_{\text{CANL}}$	V_{SYM}	$0.9 \times V_{CC}$	$1.0 \times V_{CC}$	$1.1 \times V_{CC}$	V	^{9) 10)} $C_1 = 4.7\text{ nF}$	P_8.4.10
CANH short circuit current	I_{CANHSC}	-115	-80	5	mA	$-3\text{ V} < V_{\text{CANHshort}} < 18\text{ V}$; $t < t_{\text{TxD_TO}}$; $V_{\text{TxD}} = 0\text{ V}$	P_8.4.11
CANL short circuit current	I_{CANLSC}	-5	80	115	mA	$-3\text{ V} < V_{\text{CANLshort}} < 18\text{ V}$; $t < t_{\text{TxD_TO}}$; $V_{\text{TxD}} = 0\text{ V}$	P_8.4.12
CANH leakage current	$I_{\text{CANH_Ik}}$	-3	–	3	μA	$V_{CC} = 0\text{ V}$; $0\text{ V} < V_{\text{CANH}} < 5\text{ V}$; $V_{\text{CANH}} = V_{\text{CANL}}$	P_8.4.14
CANL leakage current	$I_{\text{CANL_Ik}}$	-3	–	3	μA	$V_{CC} = 0\text{ V}$; $0\text{ V} < V_{\text{CANL}} < 5\text{ V}$; $V_{\text{CANH}} = V_{\text{CANL}}$	P_8.4.15

⁹ Not subject to production test, specified by design.

¹⁰ V_{SYM} is observed during dominant and recessive state and also during the transition from dominant to recessive and vice versa, while TxD is stimulated by a square wave signal with a frequency of 1 MHz.

Electrical characteristics

Table 10 Electrical characteristics transmitter (continued)

$V_{CC} = 4.5\text{ V to }5.5\text{ V}$; $R_L = 60\ \Omega$; $T_j = -40^\circ\text{C to }150^\circ\text{C}$;

all voltages with respect to ground, positive current flowing into pin (unless otherwise specified)

Parameter	Symbol	Values			Unit	Note or condition	Number
		Min.	Typ.	Max.			
CANH, CANL output voltage difference slope, recessive to dominant	$V_{\text{diff_slope_rd}}$	-	-	70	V/ μs	30% to 70% of measured differential bus voltage; $C_L = 100\text{ pF}$; $R_L = 60\ \Omega$; $4.75\text{ V} < V_{CC} < 5.25\text{ V}$ ⁹⁾	P_8.4.16
CANH, CANL output voltage difference slope, dominant to recessive	$V_{\text{diff_slope_dr}}$	-	-	70	V/ μs	30% to 70% of measured differential bus voltage; $C_L = 100\text{ pF}$; $R_L = 60\ \Omega$; $4.75\text{ V} < V_{CC} < 5.25\text{ V}$ ⁹⁾	P_8.4.17

7.5 Electrical characteristics receiver

Table 11 Electrical characteristics receiver

$V_{CC} = 4.5\text{ V to }5.5\text{ V}$; $R_L = 60\ \Omega$; $T_j = -40^\circ\text{C to }150^\circ\text{C}$;

all voltages with respect to ground, positive current flowing into pin (unless otherwise specified)

Parameter	Symbol	Values			Unit	Note or condition	Number
		Min.	Typ.	Max.			
Bus receiver							
Common mode Voltage Range	V_{CMR}	-12	-	12	V	-	P_8.5.1
Differential range dominant normal-operating mode	$V_{\text{Diff_D_Range}}$	0.9	-	8.0	V	¹¹⁾ V_{CMR}	P_8.5.3
Differential range recessive normal-operating mode	$V_{\text{Diff_R_Range}}$	-3.0	-	0.5	V	¹¹⁾ V_{CMR}	P_8.5.5
Single ended internal resistance	$R_{\text{CAN_H}}$, $R_{\text{CAN_L}}$	6	-	50	k Ω	recessive state, $-2\text{ V} < V_{\text{CANH}} < 7\text{ V}$; $-2\text{ V} < V_{\text{CANL}} < 7\text{ V}$	P_8.5.7

⁹⁾ Not subject to production test, specified by design.

¹¹⁾ Not subject to production test, specified by design.

Electrical characteristics

Table 11 Electrical characteristics receiver (continued)

$V_{CC} = 4.5\text{ V to }5.5\text{ V}$; $R_L = 60\ \Omega$; $T_j = -40^\circ\text{C to }150^\circ\text{C}$;

all voltages with respect to ground, positive current flowing into pin (unless otherwise specified)

Parameter	Symbol	Values			Unit	Note or condition	Number
		Min.	Typ.	Max.			
Differential internal resistance	R_{Diff}	12	–	100	k Ω	recessive state, $-2\text{ V} < V_{CANH} < 7\text{ V}$; $-2\text{ V} < V_{CANL} < 7\text{ V}$	P_8.5.8
Input resistance deviation between CANH and CANL	ΔR_i	-3.0	–	3.0	%	¹¹⁾ recessive state, $V_{CANH} = V_{CANL} = 5\text{ V}$	P_8.5.9
Input capacitance CANH, CANL versus GND	C_{In}	–	30	40	pF	recessive state ¹²⁾	P_8.5.10
Differential input capacitance	C_{InDiff}	–	2	8	pF	recessive state ¹²⁾	P_8.5.11

7.6 Electrical characteristics dynamic transceiver parameters

Table 12 Electrical characteristics propagation delay

$V_{CC} = 4.5\text{ V to }5.5\text{ V}$; $R_L = 60\ \Omega$; $T_j = -40^\circ\text{C to }150^\circ\text{C}$;

all voltages with respect to ground, positive current flowing into pin (unless otherwise specified)

Parameter	Symbol	Values			Unit	Note or condition	Number
		Min.	Typ.	Max.			
Propagation delay							
Propagation delay, TxD to RxD	t_{Loop}	80	200	235	ns	$C_L = 100\text{ pF}$; $C_{RxD} = 15\text{ pF}$	P_8.6.1
Propagation delay, TxD to bus ("low" to dominant)	$t_{d(L),T}$	30	110	140	ns	$C_L = 100\text{ pF}$; $C_{RxD} = 15\text{ pF}$	P_8.6.2
Propagation delay, TxD to bus ("high" to recessive)	$t_{d(H),T}$	30	110	140	ns	$C_L = 100\text{ pF}$; $C_{RxD} = 15\text{ pF}$	P_8.6.3
Propagation delay, bus to RxD (dominant to "low")	$t_{d(L),R}$	30	90	140	ns	$C_L = 100\text{ pF}$; $C_{RxD} = 15\text{ pF}$	P_8.6.4

¹¹ Not subject to production test, specified by design.

¹² Not subject to production test, specified by design, S2P -Method; $f = 10\text{ MHz}$.

Electrical characteristics

Table 12 **Electrical characteristics propagation delay (continued)**

$V_{CC} = 4.5\text{ V to }5.5\text{ V}$; $R_L = 60\ \Omega$; $T_j = -40^\circ\text{C to }150^\circ\text{C}$;

all voltages with respect to ground, positive current flowing into pin (unless otherwise specified)

Parameter	Symbol	Values			Unit	Note or condition	Number
		Min.	Typ.	Max.			
Propagation delay, bus to RxD (recessive to "high")	$t_{d(H),R}$	30	90	140	ns	$C_L = 100\text{ pF}$; $C_{RxD} = 15\text{ pF}$	P_8.6.5

Electrical characteristics

Table 13 Electrical characteristics CAN FD

$V_{CC} = 4.5\text{ V to }5.5\text{ V}$; $R_L = 60\ \Omega$; $T_j = -40^\circ\text{C to }150^\circ\text{C}$;

all voltages with respect to ground, positive current flowing into pin (unless otherwise specified)

Parameter	Symbol	Values			Unit	Note or condition	Number
		Min.	Typ.	Max.			
CAN FD							
Received recessive bit width at 2 MBit/s	$t_{\text{Bit(RxD)}_2\text{M}}$	400	500	550	ns	$C_L = 100\text{ pF}$; $C_{\text{RxD}} = 15\text{ pF}$; $t_{\text{Bit}} = 500\text{ ns}$ (see Figure 15)	P_8.6.6
Transmitted recessive bit width at 2 MBit/s	$t_{\text{Bit(Bus)}_2\text{M}}$	435	500	530	ns	$C_L = 100\text{ pF}$; $C_{\text{RxD}} = 15\text{ pF}$; $t_{\text{Bit}} = 500\text{ ns}$ (see Figure 15)	P_8.6.7
Receiver timing symmetry at 2 MBit/s $\Delta t_{\text{Rec}_2\text{M}} = t_{\text{Bit(RxD)}_2\text{M}} - t_{\text{Bit(Bus)}_2\text{M}}$	$\Delta t_{\text{Rec}_2\text{M}}$	-65	-	40	ns	$C_L = 100\text{ pF}$; $C_{\text{RxD}} = 15\text{ pF}$; $t_{\text{Bit}} = 500\text{ ns}$ (see Figure 15)	P_8.6.8
Received recessive bit width at 5 MBit/s	$t_{\text{Bit(RxD)}_5\text{M}}$	120	200	220	ns	$C_L = 100\text{ pF}$; $C_{\text{RxD}} = 15\text{ pF}$; $t_{\text{Bit}} = 200\text{ ns}$ $4.75\text{ V} < V_{CC} < 5.5\text{ V}$ (see Figure 15)	P_8.6.9
Received recessive bit width at 5 MBit/s	$t_{\text{Bit(Bus)}_5\text{M}}$	155	200	210	ns	$C_L = 100\text{ pF}$; $C_{\text{RxD}} = 15\text{ pF}$; $t_{\text{Bit}} = 200\text{ ns}$ $4.75\text{ V} < V_{CC} < 5.5\text{ V}$ (see Figure 15)	P_8.6.10
Receiver timing symmetry at 5 MBit/s $\Delta t_{\text{Rec}_5\text{M}} = t_{\text{Bit(RxD)}_5\text{M}} - t_{\text{Bit(Bus)}_5\text{M}}$	$\Delta t_{\text{Rec}_5\text{M}}$	-45	-	15	ns	$C_L = 100\text{ pF}$; $C_{\text{RxD}} = 15\text{ pF}$; $t_{\text{Bit}} = 200\text{ ns}$ $4.75\text{ V} < V_{CC} < 5.5\text{ V}$ (see Figure 15)	P_8.6.11

Electrical characteristics

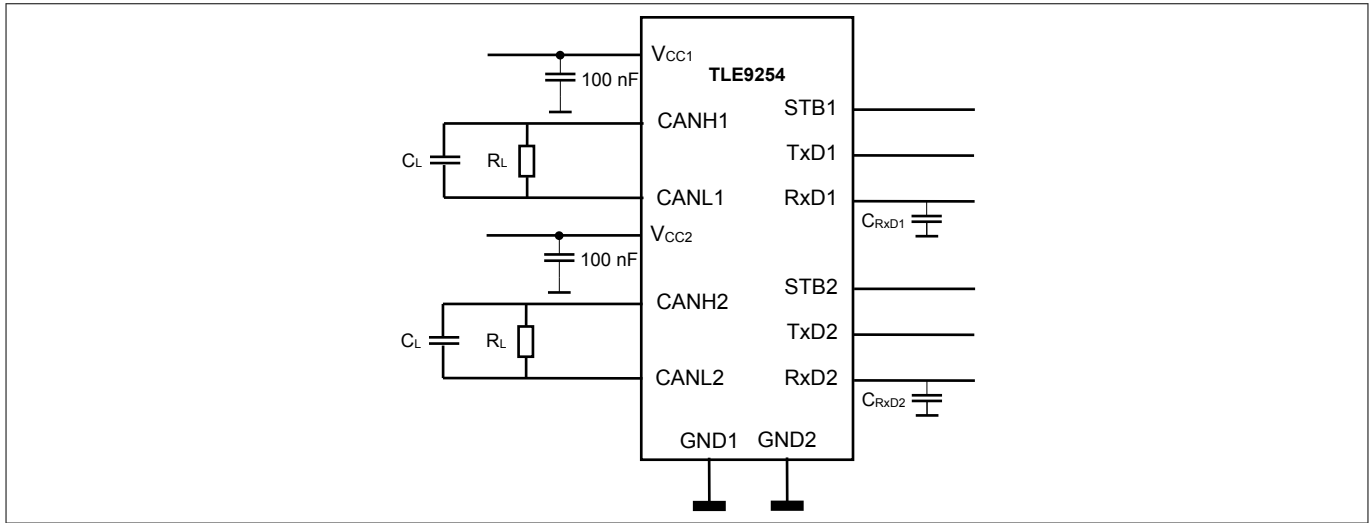

Figure 13 Test circuit for dynamic characteristics

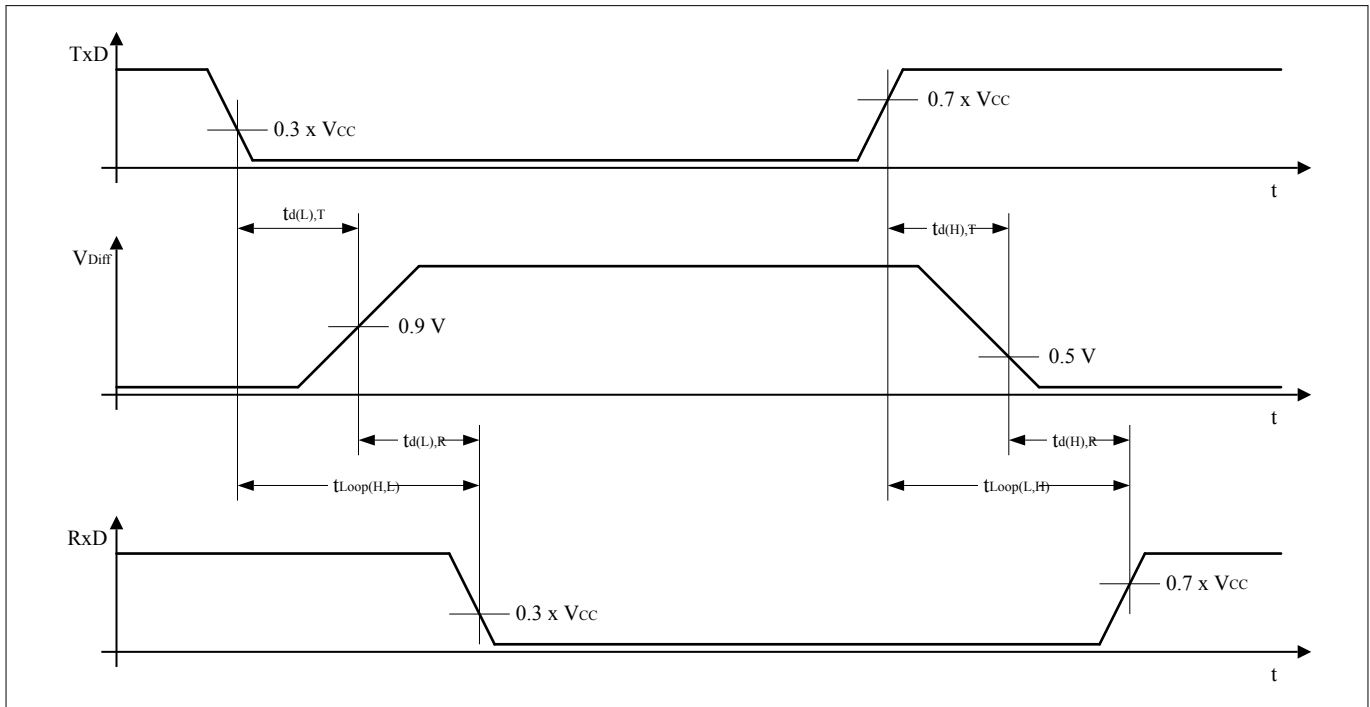

Figure 14 Timing diagram for dynamic characteristics

Electrical characteristics

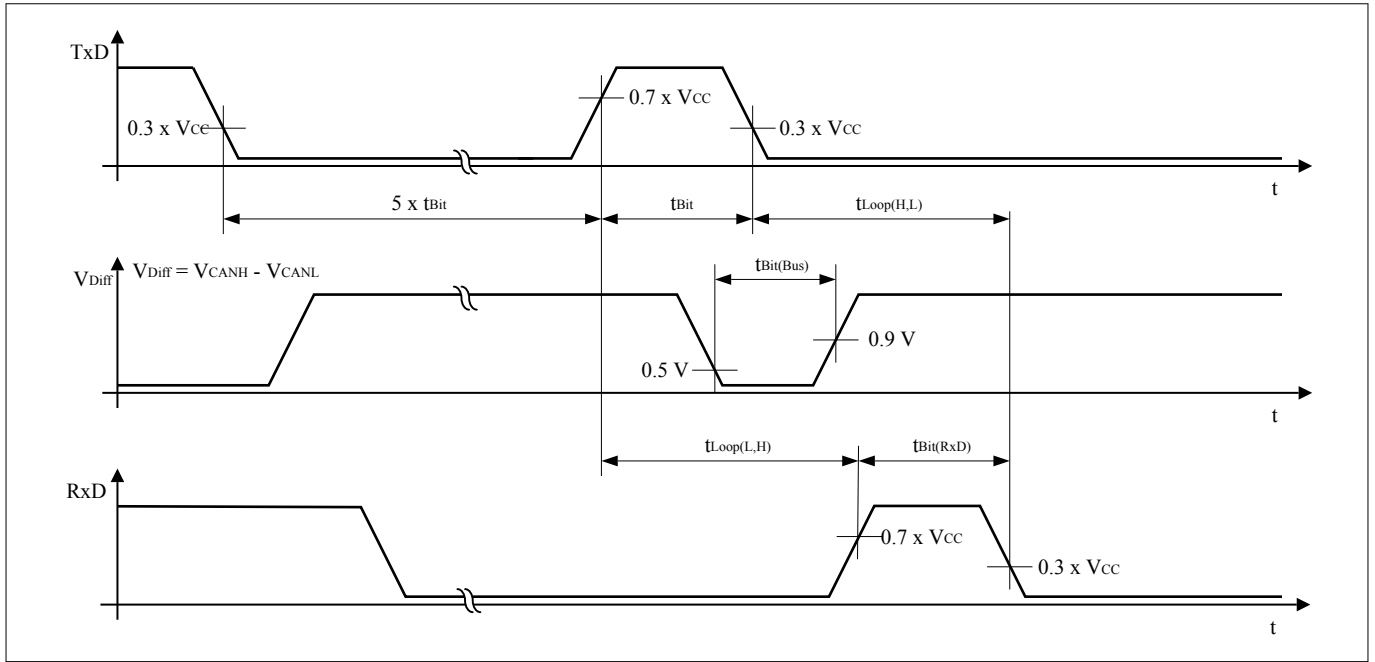

Figure 15 Recessive bit time for five dominant bits followed by one recessive bit

7.7 Electrical characteristics wake-up pattern detection

Table 14 Electrical characteristics wake-up pattern detection

$V_{CC} = 4.75\text{ V to }5.25\text{ V}$; $R_L = 60\ \Omega$; $T_j = -40^\circ\text{C to }150^\circ\text{C}$;
 all voltages with respect to ground, positive current flowing into pin (unless otherwise specified)

Parameter	Symbol	Values			Unit	Note or condition	Number
		Min.	Typ.	Max.			
Differential range dominant low power modes	$V_{Diff_D_STB_Range}$	1.15	–	8.0	V	¹³⁾ V_{CMR}	P_8.7.1
Differential range recessive low power modes	$V_{Diff_R_STB_Range}$	-3.0	–	0.4	V	¹³⁾ V_{CMR}	P_8.7.3
CAN activity filter time	t_{Filter}	0.5	–	1.8	μs	Figure 8	P_8.7.6
Bus wake-up timeout	t_{WAKE}	0.8	–	10.0	ms	Figure 8	P_8.7.7
Bus wake-up delay time	t_{WU}	–	–	5.0	μs	stand-by mode, Figure 9	P_8.7.8

¹³⁾ Not subject to production test, specified by design.

Application information

8 Application information

8.1 ESD robustness according to IEC 61000-4-2

Tests for ESD robustness according to IEC 61000-4-2 "Gun test" (150 pF, 330 Ω) have been performed. The results and test conditions are available in a separate test report.

Table 15 ESD robustness according to IEC61000-4-2

Performed Test	Result	Unit	Remarks
Electrostatic discharge voltage at pin CANH and CANL versus GND	≥ +8	kV	¹⁴⁾ Positive pulse
Electrostatic discharge voltage at pin CANH and CANL versus GND	≤ -8	kV	¹⁴⁾ Negative pulse

8.2 Application example

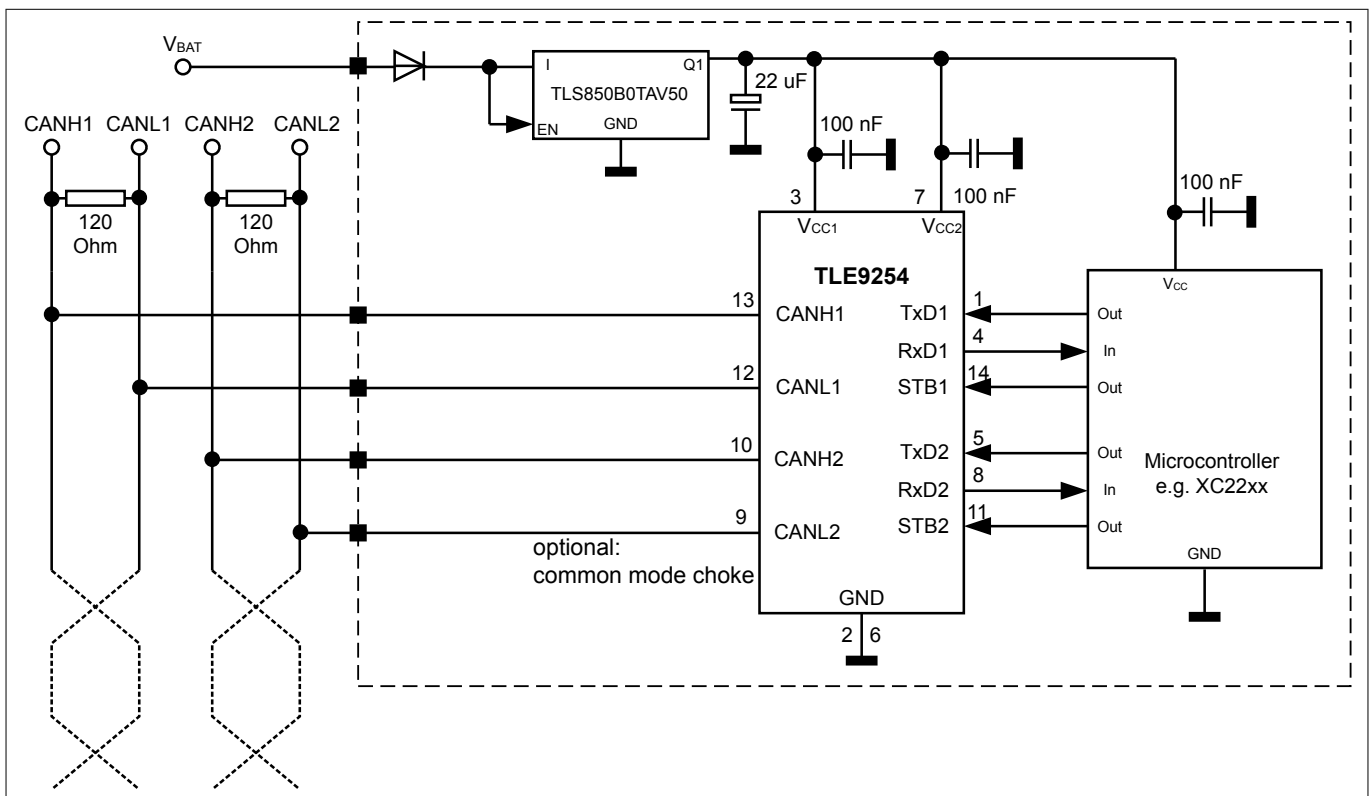

Figure 16 Application circuit

¹⁴⁾ ESD susceptibility "ESD GUN" according to GIFT / ICT paper: "EMC Evaluation of CAN Transceivers, version 03/02/IEC TS62228", section 4.3. (DIN EN 61000-4-2), Tested by external facility IBEE Zwickau.

Application information

8.3 Further application information

- Please contact us for information regarding the pin FMEA.
- For further information please visit: www.infineon.com/transceiver

Package information

9 Package information

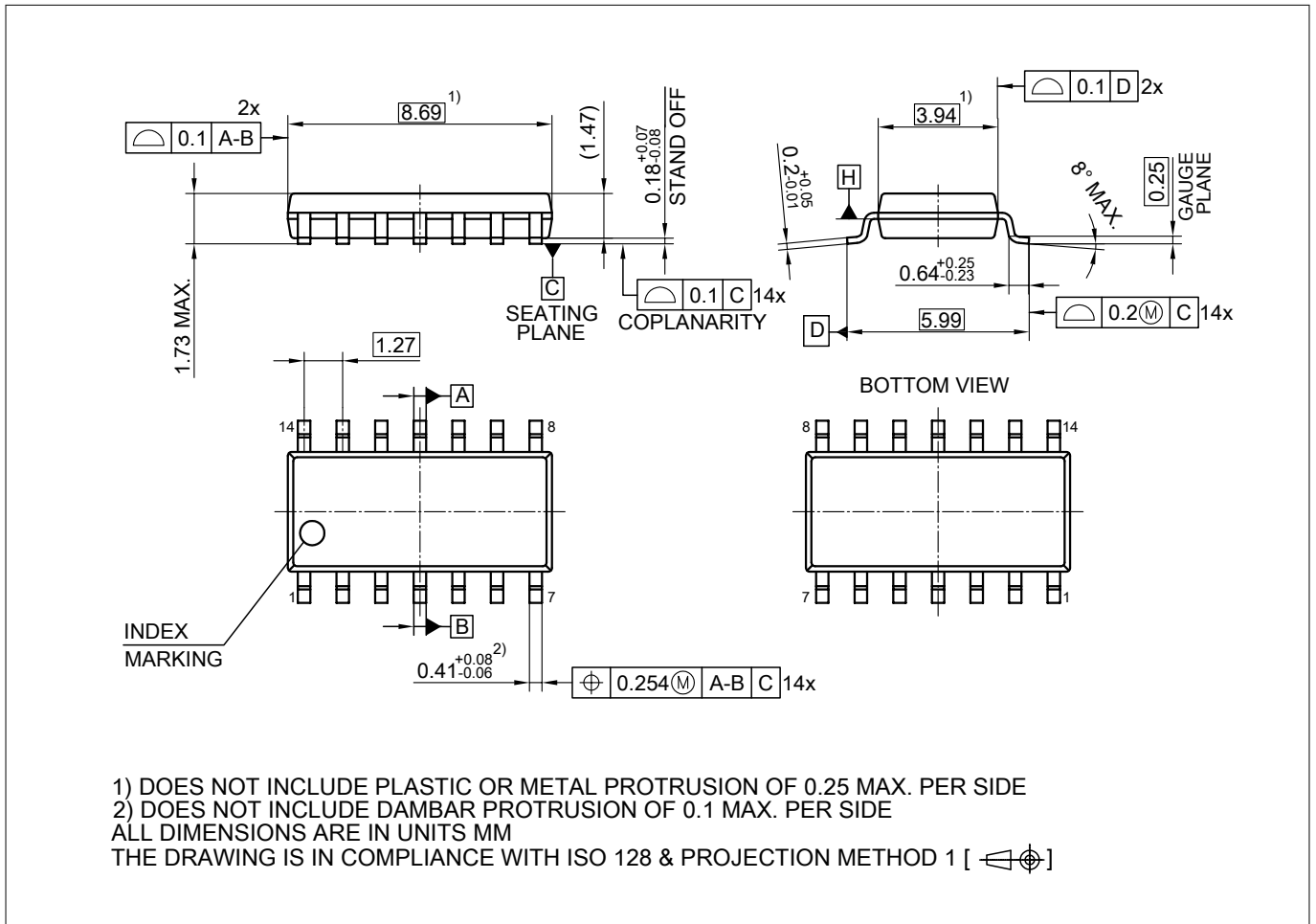

Figure 17 PG-DSO-14

Package information

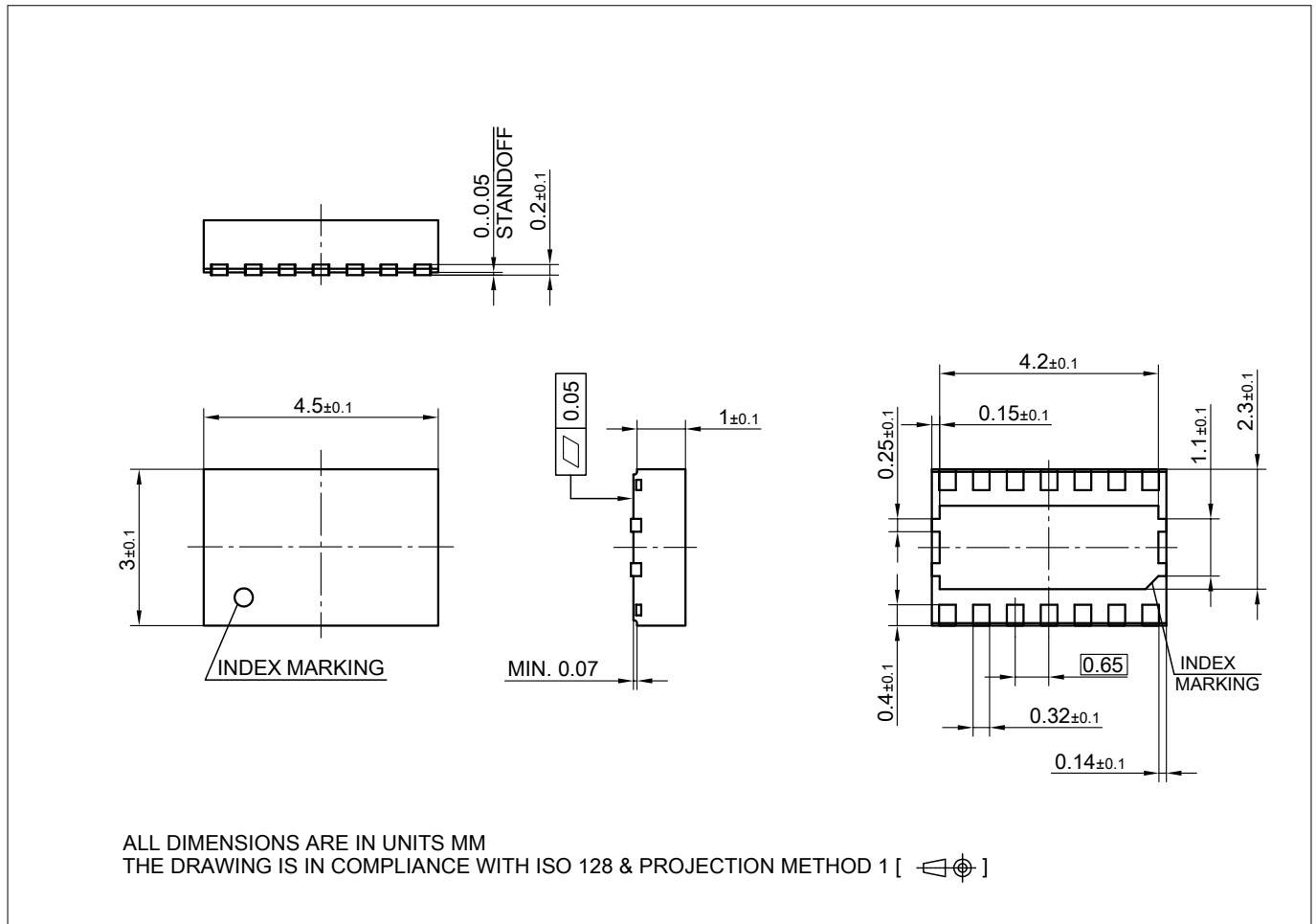

Figure 18 PG-TSON-14

Green Product (RoHS compliant)

To meet the world-wide customer requirements for environmentally friendly products and to be compliant with government regulations the device is available as a green product. Green products are RoHS-Compliant (Pb-free finish on leads and suitable for Pb-free soldering according to IPC/JEDEC J-STD-020).

Information on alternative packages

Please visit www.infineon.com/packages.

Revision history

Revision history

Revision	Date	Changes
1.0	2019-10-16	Datasheet created

Trademarks

All referenced product or service names and trademarks are the property of their respective owners.

Edition 2019-10-16

Published by

Infineon Technologies AG

81726 Munich, Germany

© 2019 Infineon Technologies AG

All Rights Reserved.

Do you have a question about any aspect of this document?

Email: erratum@infineon.com

Document reference

IFX-Z8F60658458

IMPORTANT NOTICE

The information given in this document shall in no event be regarded as a guarantee of conditions or characteristics ("Beschaffheitsgarantie").

With respect to any examples, hints or any typical values stated herein and/or any information regarding the application of the product, Infineon Technologies hereby disclaims any and all warranties and liabilities of any kind, including without limitation warranties of non-infringement of intellectual property rights of any third party.

In addition, any information given in this document is subject to customer's compliance with its obligations stated in this document and any applicable legal requirements, norms and standards concerning customer's products and any use of the product of Infineon Technologies in customer's applications.

The data contained in this document is exclusively intended for technically trained staff. It is the responsibility of customer's technical departments to evaluate the suitability of the product for the intended application and the completeness of the product information given in this document with respect to such application.

WARNINGS

Due to technical requirements products may contain dangerous substances. For information on the types in question please contact your nearest Infineon Technologies office.

Except as otherwise explicitly approved by Infineon Technologies in a written document signed by authorized representatives of Infineon Technologies, Infineon Technologies' products may not be used in any applications where a failure of the product or any consequences of the use thereof can reasonably be expected to result in personal injury