

TLI4906K / TLI4906L

High Precision Hall Effect Switches for Industrial and Consumer Applications

About this document

Overview

The TLI4906x is a high precision Hall Effect Switch with highly accurate switching thresholds for ambient operating temperatures up to 125°C. The TLI4906K is available in a PG-SC59-3-4 package, the TLI4906L in a PG-SSO-3-2 package



Features

- 2.7 V to 18 V supply voltage operation.
- Operation from unregulated power supply.
- High sensitivity and high stability of the magnetic switching points.
- High resistance to mechanical stress by active error compensation.
- Reverse battery protection (-18 V).
- Superior temperature stability.
- Low jitter (typically 1 μ s).
- High ESD performance (\pm 4 kV HBM).
- Digital output signal (open-drain).
- Not suitable for automotive applications



Target applications

The TLI4906x is ideally suited for all industrial and consumer applications that require a high precision switching thresholds for position sensing. It can be used for example for: security systems, alignment control, push buttons, keyboards, key switches, machine tools, etc.

Product name	Product type	Ordering code	Package
Hall Effect Switch	TLI4906K	SP000604306	PG-SC59-3-4
Hall Effect Switch	TLI4906L	SP000604320	PG-SSO-3-2

Table of contents

	About this document	1
	Table of contents	2
1	Functional description	3
1.1	General	3
1.2	Pin configuration	3
1.3	Pin description	3
1.4	Block diagram	4
1.5	Operating modes and states	4
1.6	Functional block description	5
2	Specification	6
2.1	Application circuit	6
2.2	Absolute maximum ratings	6
2.3	Operating range	7
2.4	Electrical characteristics	7
3	Package information	9
3.1	TLI4906K Package outline	9
3.2	TLI4906L Package outline	10
	Revision history	12
	Disclaimer	13

1 Functional description

1 Functional description

1.1 General

Precise magnetic switching thresholds and high temperature stability are achieved by active compensation circuits and chopper techniques on chip. Offset voltages generated by temperature-induced stress or overmolding are canceled so that high accuracy is achieved. The IC has an open collector output stage with 20 mA current sink capability. A wide operating voltage range from 2.7 V to 18 V with reverse polarity protection down to -18 V makes the TLI4906x suitable for a wide range of applications. A magnetic south pole with a field strength above B_{op} turns the output on. A magnetic north pole exceeding B_{rp} turns it off.

1.2 Pin configuration

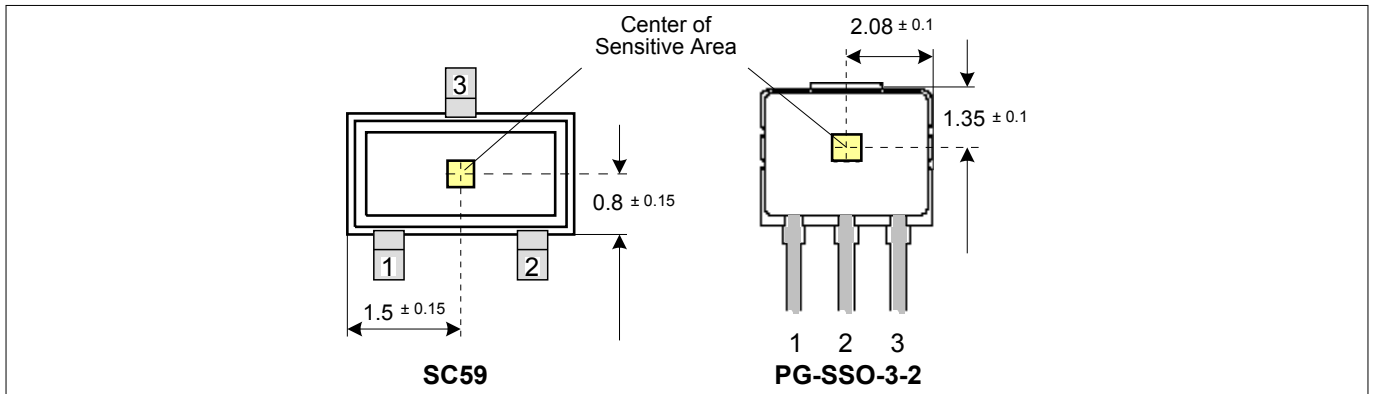

Figure 1 Pin configuration and sensitive area (Top view, figure not to scale)

1.3 Pin description

Table 1 PIN definitions for the PG-SC59-3-4 package

PIN No.	Name	Function
1	V_S	Supply voltage
2	Q	Output
3	GND	Ground

Table 2 PIN definitions for the PG-SSO-3-2 package

PIN No.	Name	Function
1	V_S	Supply voltage
2	GND	Ground
3	Q	Output

1 Functional description

1.4 Block diagram

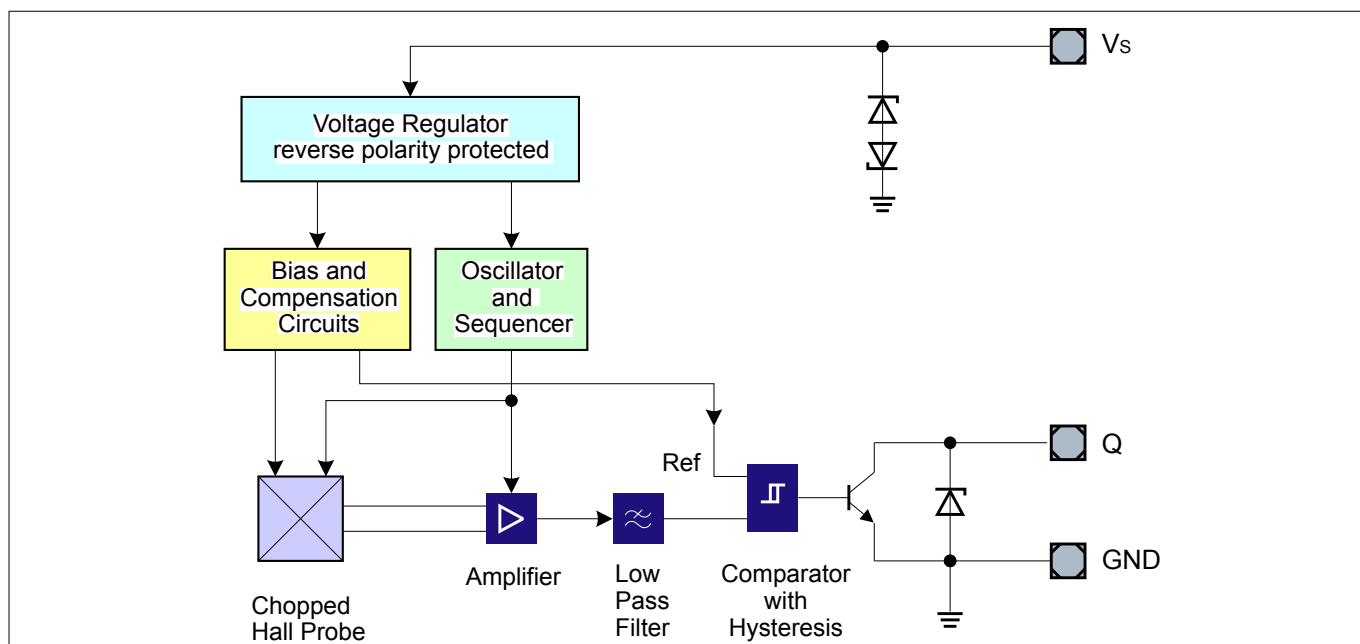

Figure 2 TLI4906x Block diagram

1.5 Operating modes and states

Field direction and definition

Positive magnetic fields correspond to the south pole of the magnet targeting the branded side of the package.

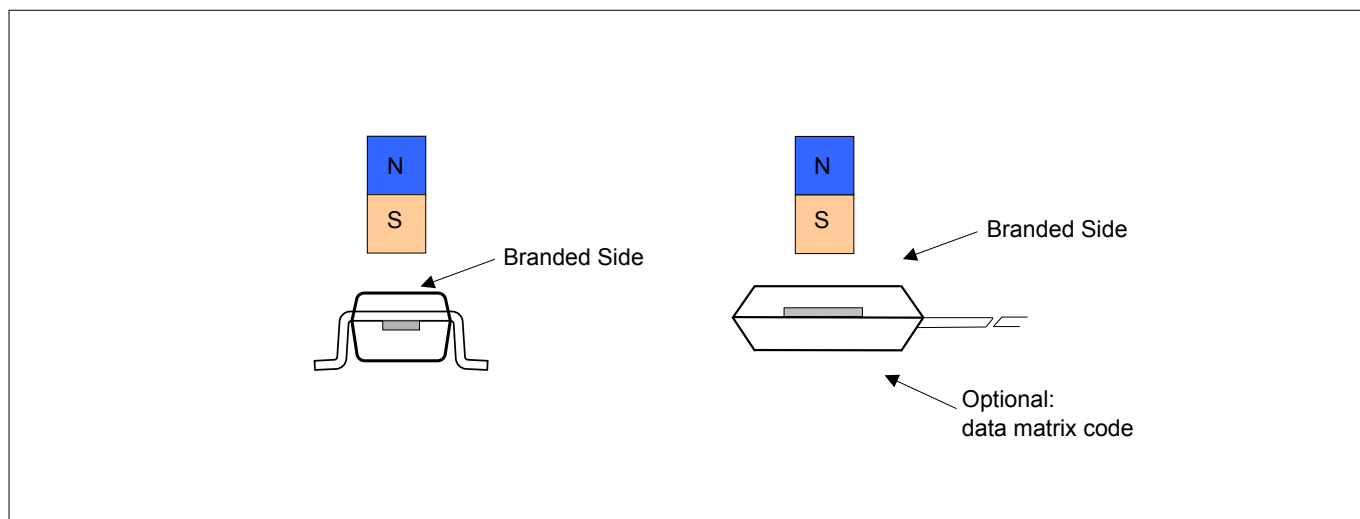

Figure 3 Definition of the magnetic field direction

1 Functional description

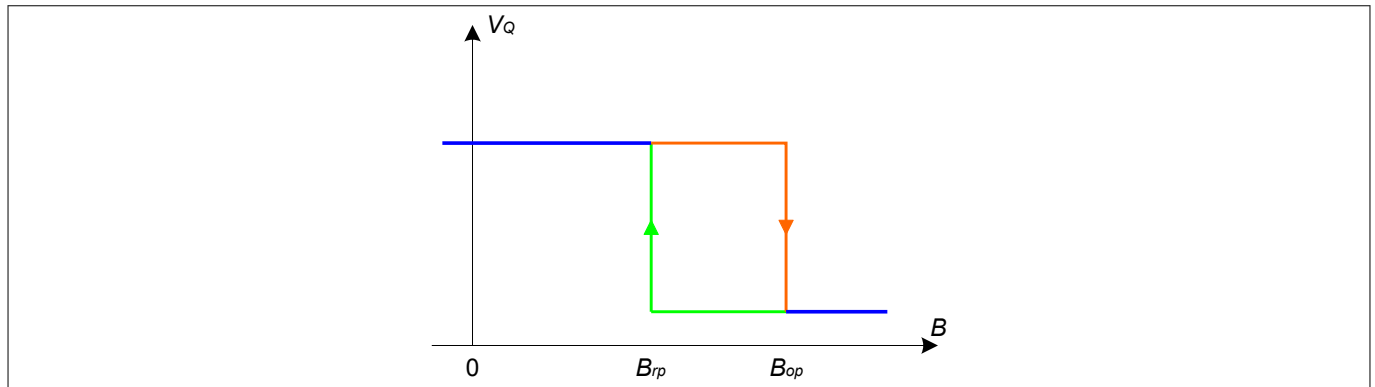

Figure 4 Output signal

1.6 Functional block description

The chopped Hall Effect Switch comprises a Hall probe, a bias generator, compensation circuits, an oscillator and an output transistor. The bias generator provides currents to the Hall probe and the active circuits. Compensation circuits stabilize response of the IC over temperature and reduce the impact of process variations. The Active Error Compensation rejects offsets in the signal path and reduces the impact of mechanical stress in the package caused by molding, soldering and thermal effects. The chopper technique together with the threshold generator and the comparator ensure high accurate magnetic switching points.

2 Specification

2 Specification

2.1 Application circuit

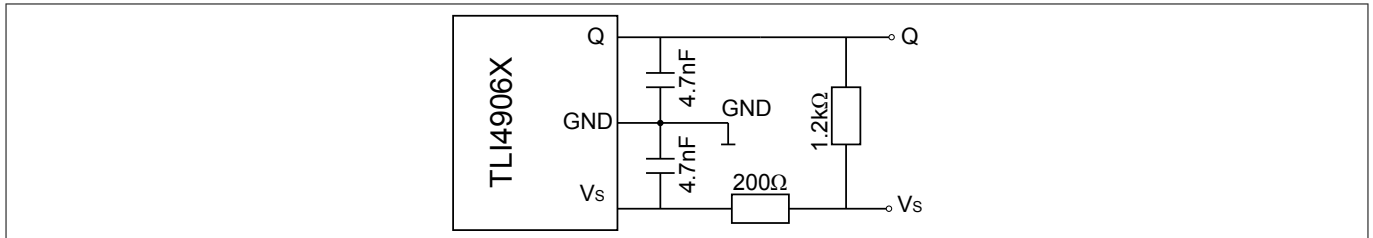

Figure 5 Application circuit

It is recommended to use a resistor of 200 Ω in the supply line for current limitation in the case of an overvoltage pulse. Two capacitors of 4.7 nF enhance the EMC performance. The pull-up of 1.2 kΩ limits the current through the output transistor.

2.2 Absolute maximum ratings

Stress above the maximum values listed in this section may cause permanent damage to the device. Exposure to absolute maximum rating conditions for extended periods may affect the reliability of the device. Exceeding only one of these values may cause irreversible damage to the device.

Table 3 Absolute maximum ratings

Parameter	Symbol	Values			Unit	Note/Test Condition
		Min.	Typ.	Max.		
Maximum Ambient Temperature	T_A	40	–	125	°C	
Maximum Junction Temperature	T_J	-40	–	150	°C	
Supply Voltage	V_S	-18	–	18	V	
Supply current through protection device	I_S	-50	–	50	mA	
Output Voltage	V_{OUT}	-0.7	–	18	V	
Storage Temperature	T_S	-40	–	150	°C	
Magnetic flux density	B	–	–	unlimited	mT	
ESD Robustness HBM: 1.5 kΩ, 100 pF	$V_{ESD,HBM}^{(1)}$	–	–	4	kV	

(1) According to EIA/JESD22-A114-E

2 Specification

2.3 Operating range

The following operating conditions must not be exceeded in order to ensure correct operation of the TLI4906x. All parameters specified in the following sections refer to these operating conditions unless otherwise mentioned.

Table 4 Operating range

Parameter	Symbol	Values			Unit	Note/Test Condition
		Min.	Typ.	Max.		
Supply Voltage	V_S	2.7	–	18	V	
Output Voltage	V_Q	-0.7	–	18	V	
Output Current	I_Q	0	–	20	mA	
Maximum Ambient Temperature	T_A	-40	–	125	°C	

2.4 Electrical characteristics

Product characteristics include the spread of values guaranteed within the specified voltage and ambient temperature range. typical characteristics are the median of the production (at $V_S = 12\text{ V}$ and $T_A = 25^\circ\text{C}$).

Table 5 Electrical Characteristics table template

Parameter	Symbol	Values			Unit	Note/Test Condition
		Min.	Typ.	Max.		
Supply Current	I_S	2	4	6	mA	$V_S = 2.7\text{ V} \dots 18\text{ V}$
Reverse Current	I_{SR}	0	0.2	1	mA	$V_S = -18\text{ V}$
Output Saturation Voltage	V_{QSAT}	–	0.3	0.6	V	$I_Q = 20\text{ mA}$
Output leakage current	I_{QLEAK}	–	0.05	10	μA	$V_Q = 18\text{ V}$
Output fall time ⁽¹⁾	t_f	–	0.02	1	μs	$R_L = 1.2\text{ k}\Omega$, $C_L = 50\text{ pF}$
Output rise time ⁽¹⁾	t_r	–	0.4	1	μs	
Chopper frequency	f_{OSC}	–	320	–	kHz	
Switching frequency	f_{SW}	0	–	15 ⁽²⁾	kHz	
Delay time ⁽³⁾	t_d	–	13	–	μs	
Output jitter ⁽⁴⁾	t_{QJ}	–	1	–	μs_{RMS}	Typical value for a 1 kHz square wave signal
Power-on Time ⁽⁵⁾	t_{PON}	–	13	–	μs	$V_S > 2.7\text{ V}$
Thermal Resistance junction to ambient ⁽⁶⁾	R_{thja}	–	100	–	K/W	TLI4906L
		–	–	190	K/W	TLI4906L

(1) See Figure 6

(2) To operate the sensor at maximum switching frequency, the value of the magnetic signal amplitude must be 1.4 times higher than the static fields. This is due to the -3 dB corner frequency of the low pass filter in the signal path.

2 Specification

- (3) Systematic delay between magnetic threshold reached and output.
- (4) Jitter is the unpredictable deviation of the output switching delay.
- (5) Time from applying $V_S \times > 2.7\text{ V}$ to the sensor until the output state is valid.
- (6) Relationship between junction and ambient temperature: $T_J = T_{amb} + R_{thja} \times (V_S \times I_S + V_{QS} \times I_Q)$.

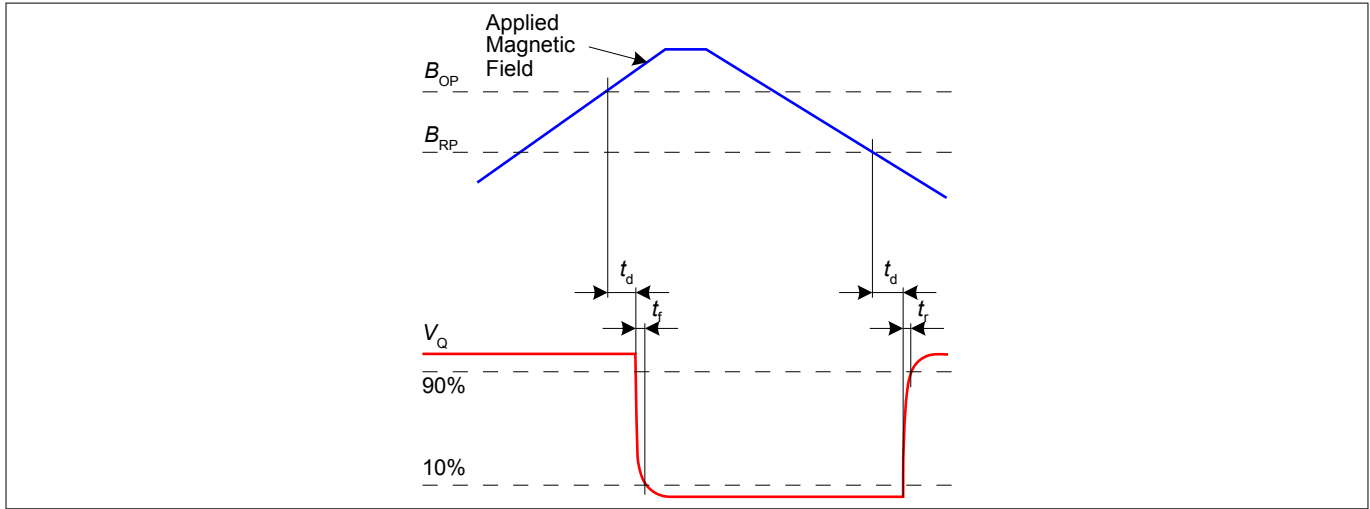

Figure 6 Timing diagram

Table 6 Magnetic characteristics⁽¹⁾

Parameter	Symbol	Values			Unit	Note/Test Condition
		Min.	Typ.	Max.		
Operate point	B_{OP}	6.2	10.0	13.9	mT	
Release point	B_{RP}	4.7	8.5	12.3	mT	
Hysteresis	B_{HYS}	0.7	1.5	3.0	mT	⁽²⁾
Temperature compensation of magnetic thresholds	TC	-	-350	-	ppm/°C	
Repeatability of magnetic thresholds ⁽³⁾	B_{REP}	-	20	-	μT_{RMS}	typical value for $\Delta B/\Delta t > 12\text{ mT/ms}$

- (1) Over all operating conditions.
- (2) At 25°C.
- (3) B_{REP} is equivalent to the noise constant.

3 Package information

3 Package information

3.1 TLI4906K Package outline

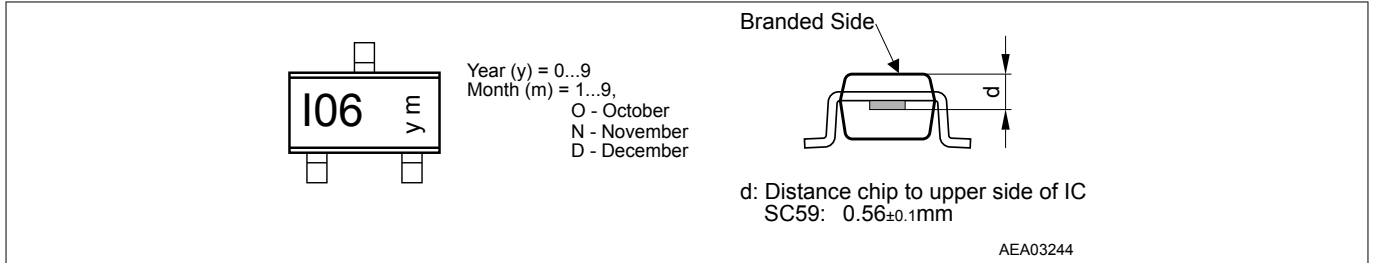

Figure 7 Marking of the TLI4906K and distance of the chip to the upper side

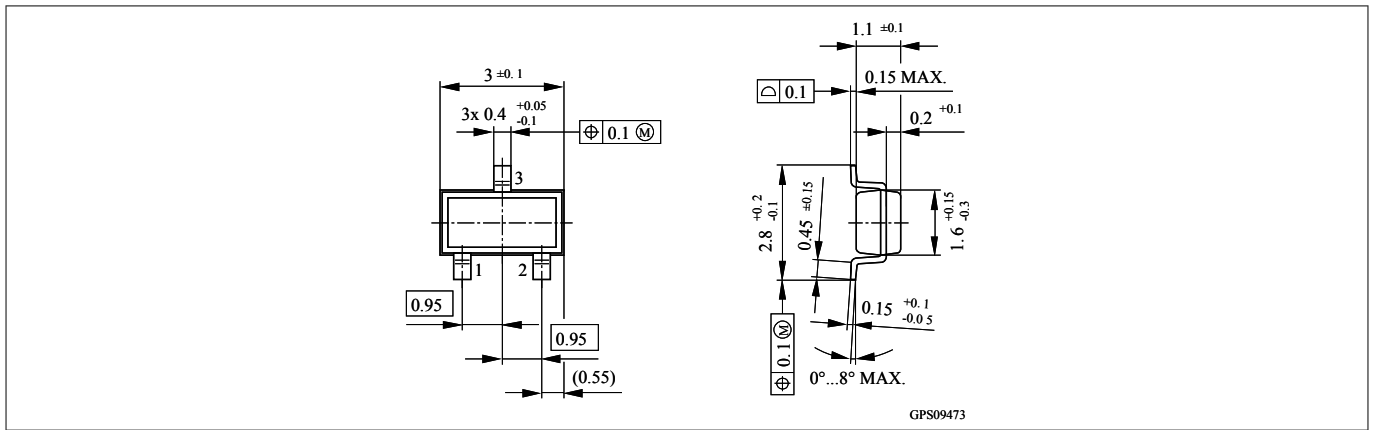

Figure 8 PG-SC59-3-4 Package outline

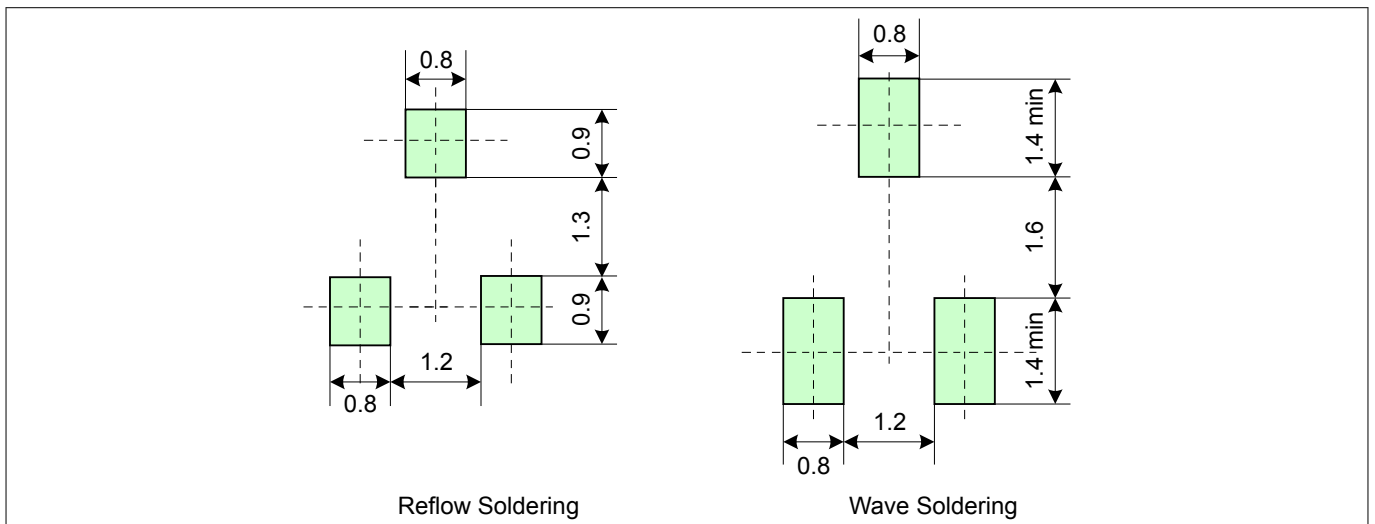

Figure 9 Footprint PG-SC59-3-4 (SOT23 compatible)

3 Package information

3.2 TLI4906L Package outline

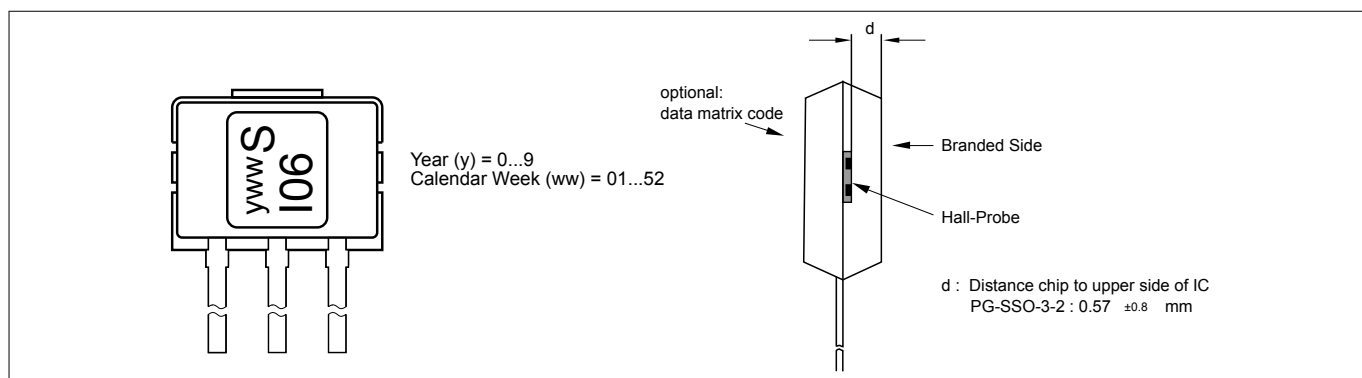

Figure 10 Marking of the TLI4906L and distance of the chip to the upper side

3 Package information

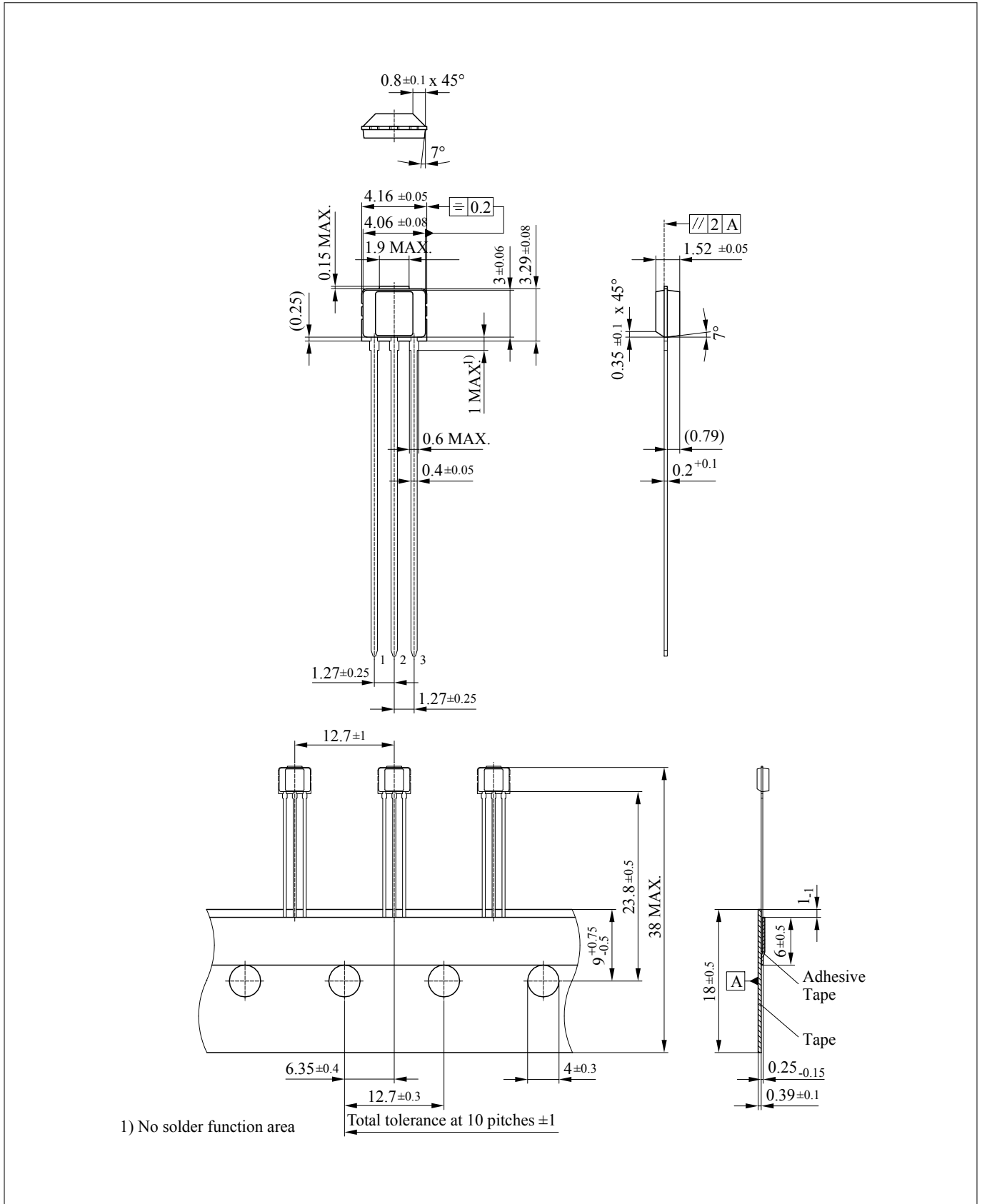

Figure 11 PG-SSO-3-2 Package outline

Revision history

Revision history

Revision History

Page	Subjects (major changes since last revision)
-------------	---

Revision History: 2020-08, Rev. 1.1

Previous Revisions: 1.0

15	Edited figure 10 (optional: data matrix code)

Trademarks

All referenced product or service names and trademarks are the property of their respective owners.

Edition 2020-08

**Published by
Infineon Technologies AG
81726 Munich, Germany**

**© 2020 Infineon Technologies AG
All Rights Reserved.**

**Do you have a question about any
aspect of this document?**

Email: erratum@infineon.com

**Document reference
IFX-gyo1596632035254**

IMPORTANT NOTICE

The information given in this document shall in no event be regarded as a guarantee of conditions or characteristics ("Beschaffheitsgarantie").

With respect to any examples, hints or any typical values stated herein and/or any information regarding the application of the product, Infineon Technologies hereby disclaims any and all warranties and liabilities of any kind, including without limitation warranties of non-infringement of intellectual property rights of any third party.

In addition, any information given in this document is subject to customer's compliance with its obligations stated in this document and any applicable legal requirements, norms and standards concerning customer's products and any use of the product of Infineon Technologies in customer's applications.

The data contained in this document is exclusively intended for technically trained staff. It is the responsibility of customer's technical departments to evaluate the suitability of the product for the intended application and the completeness of the product information given in this document with respect to such application.

WARNINGS

Due to technical requirements products may contain dangerous substances. For information on the types in question please contact your nearest Infineon Technologies office.

Except as otherwise explicitly approved by Infineon Technologies in a written document signed by authorized representatives of Infineon Technologies, Infineon Technologies' products may not be used in any applications where a failure of the product or any consequences of the use thereof can reasonably be expected to result in personal injury.