

TLI4970-D050T5

Coreless magnetic current sensor for AC and DC measurements

TLI4970-D050T5

About this document

Scope and purpose

This datasheet gives an overview of the features, functionalities, specification and interfaces of the Infineon TLI4970-D050T5 current sensor, a miniature coreless magnetic current sensor for AC and DC measurements with digital interface and fast overcurrent detection, as well as information about available package size and ordering.

Intended audience

This datasheet is primarily intended for Current Sensor Module Developers who wish to gain information about the characteristics of the Infineon TLI4970-D050T5 current sensor.

Table of contents

Table of contents

	About this document	1
	Table of contents	2
	List of tables	4
	List of figures	5
1	Product Description	6
1.1	Overview	6
1.2	Features	6
1.3	General Information	7
1.4	Target Applications	7
2	Functional Description	8
2.1	Pin Configuration	8
2.2	Block Diagram	9
2.3	Functional Description	9
2.4	Transfer Function	10
2.5	Filter Settings	11
2.6	Increased Temperature Range	13
3	Specification	14
3.1	Absolute Maximum Ratings	14
3.2	Operating Conditions	14
3.3	Fast Over Current Output	17
3.4	Application Circuit	18
3.5	Isolation Characteristics	19
3.6	CSA Component Acceptance	20
3.6.1	Board Description for CSA Component Acceptance Test Conditions	20
4	Interfaces	22
4.1	SPI Interface Definition	22
4.1.1	Logical Interface	22
4.1.1.1	Protocol Description	22
4.1.1.2	Description of the SPI Data Frames	22
4.1.1.2.1	General structure of the 16-bit SPI data frame	22
4.1.1.3	Sensor Current Message	23
4.1.1.3.1	Structure of the Sensor Value Message	23
4.1.1.4	Sensor Status Message	23
4.1.1.4.1	Structure of the Sensor Status Message	23
4.1.2	Physical SPI Interface	24
4.2	Serial Inspection and Configuration Interface (SICI)	26
5	Package	27

Table of contents

5.1	PG-TISON-8-1 Package Outline	27
5.2	Packing	28
5.3	Footprint Recommendation	29
5.4	PCB Layout Recommendation	29
5.5	Laser Marking	30
6	Revision History	31
	Disclaimer	32

List of tables

List of tables

Table 1	Order Information	6
Table 2	Pin Definition and Function	8
Table 3	Overview about bandwidth and response time	11
Table 4	Absolute Maximum Ratings	14
Table 5	Electrical Operating Parameters	14
Table 6	Accuracy Parameters	15
Table 7	OCD Output Parameter	17
Table 8	Typical Application Values	18
Table 9	Isolation Parameters according to IEC 60747-5-2	19
Table 10	Isolation Parameters according to UL 1577	19
Table 11	Absolute maximum ratings according to CSA component acceptance	20
Table 12	Test board parameters	20
Table 13	Heat sink parameters	21
Table 14	Interface Timing Parameters (5 MHz SPI clock speed)	25
Table 15	Interface Electrical Characteristics (5 MHz SPI clock speed)	25

List of figures

List of figures

Figure 1	TLI4970-D050T5 device in PG-TISON-8-1 package	6
Figure 2	Pin configuration PG-TISON-8-1	8
Figure 3	Functional block diagram of the TLI4970-D050T5	9
Figure 4	Transfer function	10
Figure 5	Bode plots for different filter settings	12
Figure 6	Distribution of the maximum total error	16
Figure 7	Application circuit for readout of multiple sensors in parallel bus mode	18
Figure 8	Test board setting	20
Figure 9	Dimension and layout of test board	21
Figure 10	Heat sink dimension (in mm)	21
Figure 11	SPI interface timing: Readout of sensor data	25
Figure 12	PG-TISON-8-1 package dimensions	27
Figure 13	Carrier tape of the PG-TISON-8-1 package	28
Figure 14	Footprint recommendation for reflow soldering	29
Figure 15	PCB layout recommendation	29
Figure 16	Laser marking on the top side	30

1 Product Description

1 Product Description



1.1 Overview

The TLI4970-D050T5 is an accurate coreless magnetic current sensor. Thus, the output signal is highly linear and without hysteresis. However, a differential measurement principle allows effective stray field suppression. Due to the integrated primary conductor (current rail), there is no need for external calibration. Additionally, a separate interface pin (OCD) provides a fast output signal in case a current exceeds a pre-set threshold. A small leadless package (QFN-like) allows for standard SMD assembly.

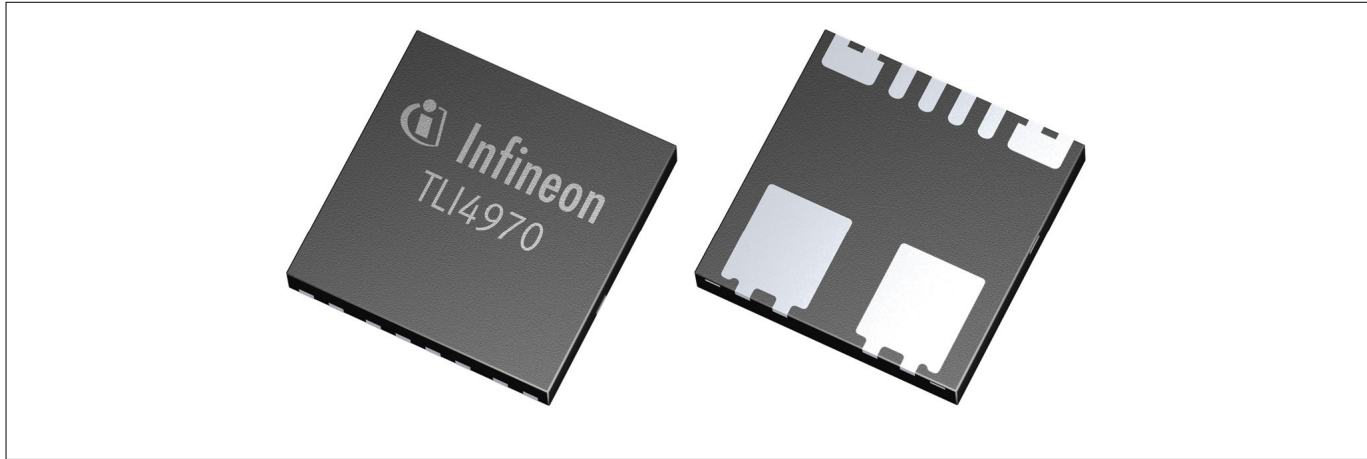

Figure 1 TLI4970-D050T5 device in PG-TISON-8-1 package

1.2 Features

- AC & DC measurement range up to ± 25 A
- Accurate over temperature range and lifetime
max. 2.9% (0 h), max. 3.5% (over lifetime) of indicated value
- Low offset error (max. 25 mA at room temperature)
- High magnetic stray field suppression
- Fast over current detection with configurable threshold
- Galvanic isolation up to 2.5 kV max. rated isolation voltage (according to UL 1577)
- 16 bit digital SPI output (13 bit current value)
- Small 7 mm x 7 mm SMD package

Table 1 Order Information

Product Name	Product Type	Package	Ordering Number
TLI4970-D050T5	Qualified according to industrial standards: For use in industrial / consumer applications	PG-TISON-8-1	SP001323146

1 Product Description

1.3 General Information

The TLI4970-D050T5 is an accurate digital current sensor. The full scale measurement range is ± 50 A. The sensor is based on Infineon's well-established and robust Hall technology.

The measurement principle allows galvanic isolation (functional isolation) between the primary conductor and the secondary interface side.

The coreless concept without a flux concentrator allows significant miniaturization. It shows no hysteresis effects and has enhanced linearity and over current capability compared to existing solutions. The differential measurement principle achieves best-in-class suppression of magnetic stray fields. The sensor is fully calibrated; no need for any additional calibration after PCB assembly is necessary. Thus, the overall implementation effort and costs are significantly reduced. It is a plug-and-play solution, easy to use in industrial and consumer applications.

The accuracy of the TLI4970-D050T5 is comparable to closed-loop current measurement systems and even better than open-loop systems with magnetic core. But in comparison to the open- and closed-loop system the TLI4970-D050T5 enables a significantly smaller footprint and less power consumption.

Infineon's patented stress compensation circuit provides outstanding long-term stability of the output signal. Proprietary dynamic offset cancellation techniques guarantee particularly low zero point error. Hereby, the TLI4970-D050T5 offers superior performance.

The TLI4970-D050T5 is based on a digital concept. Thus, signal processing, compensation and calibration is already integrated. No further external measurements for compensation are needed.

The sensor is provided in a small 7 mm x 7 mm SMD package.

1.4 Target Applications

The TLI4970-D050T5 is suitable for AC as well as DC current measurement applications:

- Current monitoring
- Chargers
- Photovoltaic & general purpose inverters
- Power supplies (SMPS)
- Electrical drive
- etc.

With its implemented magnetic interference suppression, it is extremely robust when exposed to external magnetic fields. It is also suitable for fast over current detection with a configurable threshold level. This allows the control unit to switch off and protect the affected system from damage, independently of the main measurement path.

2 Functional Description

2 Functional Description

2.1 Pin Configuration

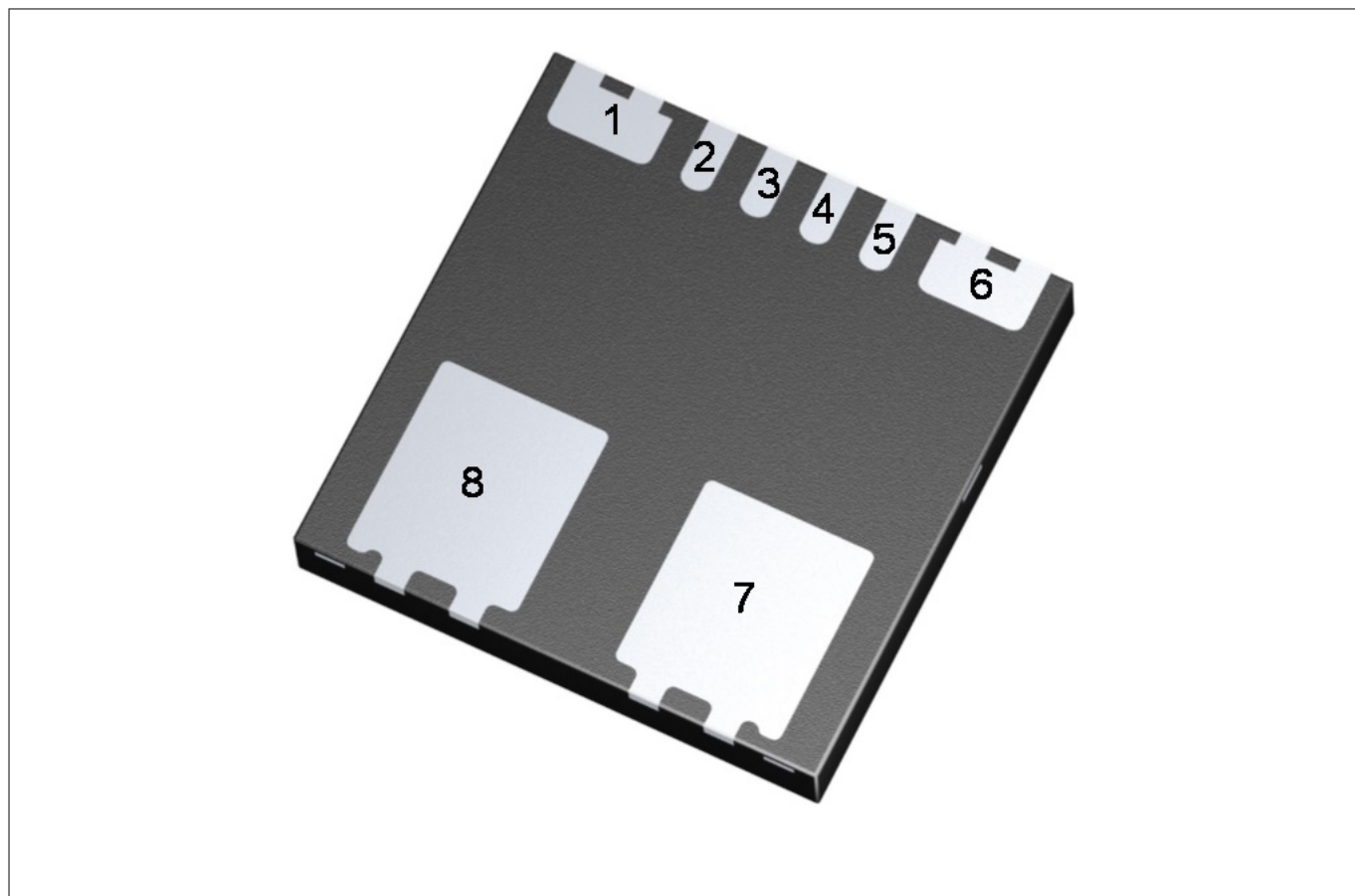

Figure 2 Pin configuration PG-TISON-8-1

Table 2 Pin Definition and Function

Pin No.	Symbol	Function
1	GND	Ground
2	VDD	Supply voltage
3	DOUT	SPI data out
4	SCLK	Serial clock input
5	\overline{CS}	Chip select input (low-active)
6	OCD	Over current detection output (open drain output)
7	IP+	Positive current terminal pin (current-in)
8	IP-	Negative current terminal pin (current-out)

2 Functional Description

2.2 Block Diagram

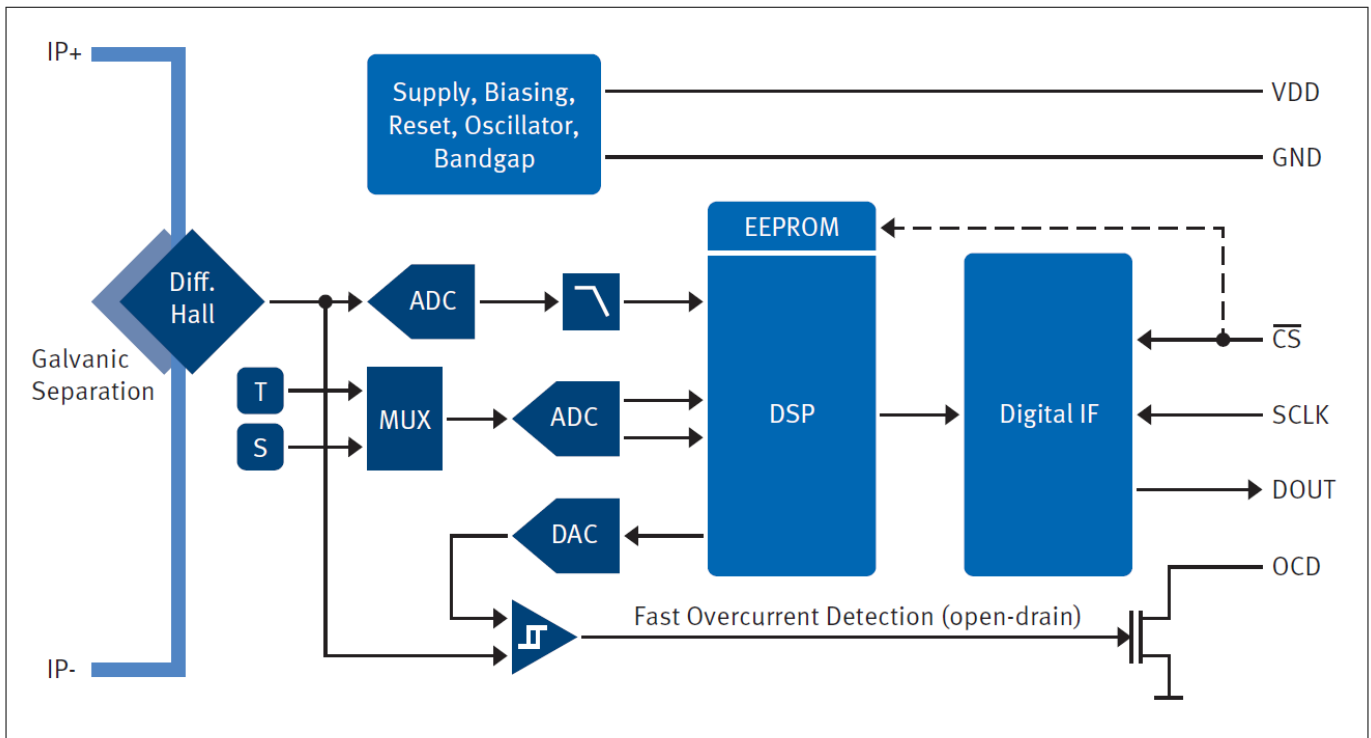

Figure 3 Functional block diagram of the TLI4970-D050T5

2.3 Functional Description

The current, flowing through the current rail on the primary side, induces a magnetic field. This is measured by two differential Hall probes. The signal from the two Hall probes is directly digitalized by a Sigma-Delta-A/D converter (ADC). After the programmable digital low-pass filter, the raw current signal is fed into the DSP. The differential measurement principle of the magnetic field provides a very good suppression of any ambient magnetic stray fields.

The temperature (T) and the mechanical stress (S) of the chip are measured and converted independently of the primary current by a second ADC. The Digital Signal Processing Unit (DSP) uses both temperature and stress information to compensate the raw current signal according to internally stored calibration tables. The interface unit (IF) transmits the fully compensated value via the SPI interface.

Furthermore several parameters like low pass filter settings or over current detection (OCD) levels can be programmed via a Serial Inspection and Configuration Interface (SICI) which are described in the TLI4970 programming guide.

For fast over current detection, the raw analog signal from the Hall probes is fed into a programmable comparator. This comparator has a programmable glitch filter to suppress fast switching transients in the signal and to avoid false triggers. The open-drain output of the OCD-Pin allows readout of over current signals for several TLI4970-D050T5 sensors by only one microcontroller input pin.

2 Functional Description

2.4 Transfer Function

The transfer function is given by the formula shown in *Equation 1*.

$$I_{out}[A] = \frac{out[LSB_D] - 4096[LSB_D]}{80 \left[\frac{LSB_D}{A} \right]}$$

$$out[LSB_D] = I[A] \cdot 80 \left[\frac{LSB_D}{A} \right] + 4096[LSB_D]$$

Equation 1

Transfer function formula

The basic points are defined by the value 0_D (-51.200A) and 8191_D (51.1875A) Outside this current range, the sensor status message will be sent instead of the sensor current message (see *Figure 4*).

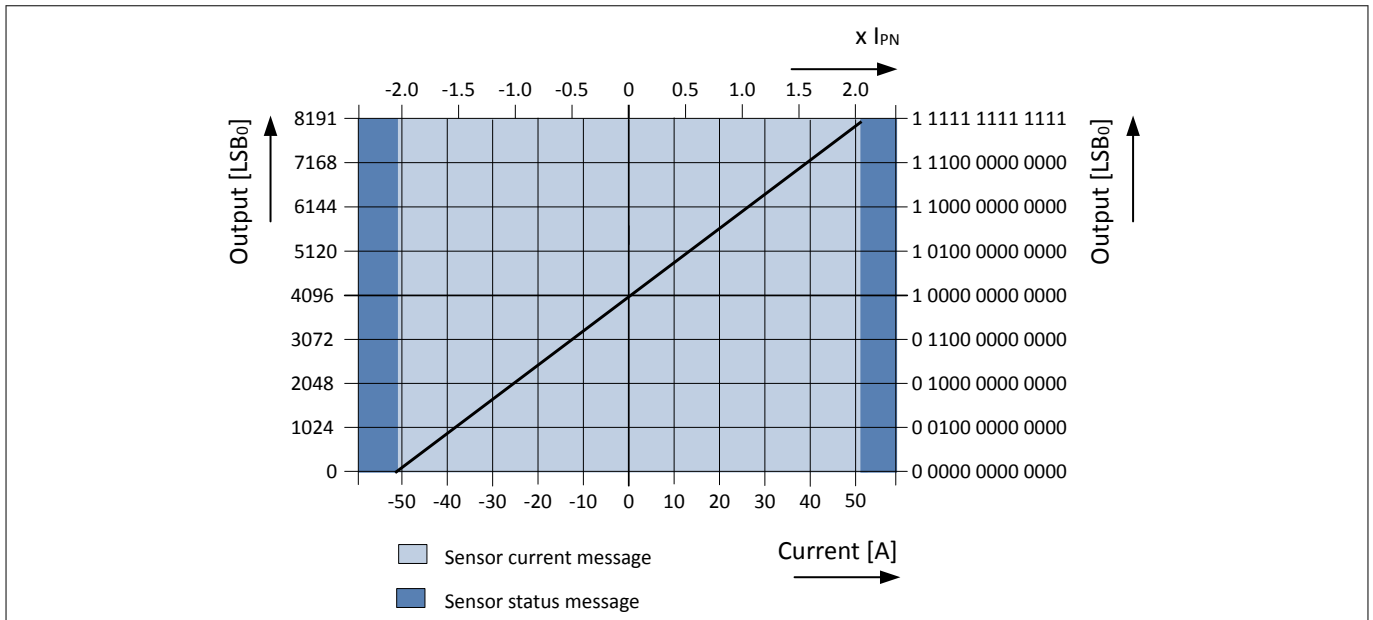

Figure 4 Transfer function

2 Functional Description

2.5 Filter Settings

The transfer function of the TLI4970-D050T5 can be influenced by different filter settings. Finally the combination of a high-pass filter, a prediction filter and a low-pass filter determines the overall transfer function. **Figure 5** shows the Bode plots for different filter settings. The filter settings can be changed by EEPROM programming. The manual for EEPROM programming can be found in the TLI4970 programming guide (application note).

Table 3 gives an overview about the different filter settings.

Table 3 Overview about bandwidth and response time

High-pass filter	Prediction filter	Low-pass filter	Bandwidth	Response time ¹⁾
1	1	7	70 Hz	6.2 ms
1	1	6	130 Hz	3.1 ms
1	1	5	260 Hz	1.6 ms
1	1	4	530 Hz	781 μ s
1	1	3	1.1 kHz	394 μ s
1	1	2	2.4 kHz	201 μ s
1	1	1	5.2 kHz	109 μ s
1	1	0	6.9 kHz	92 μ s
0	0	0	10 kHz	70 μ s
0	1	0	18 kHz	57 μ s

Note: TLI4970-D050T5 default factory setting is 18 kHz.

¹ 90% of final value based on 50 A step function

2 Functional Description

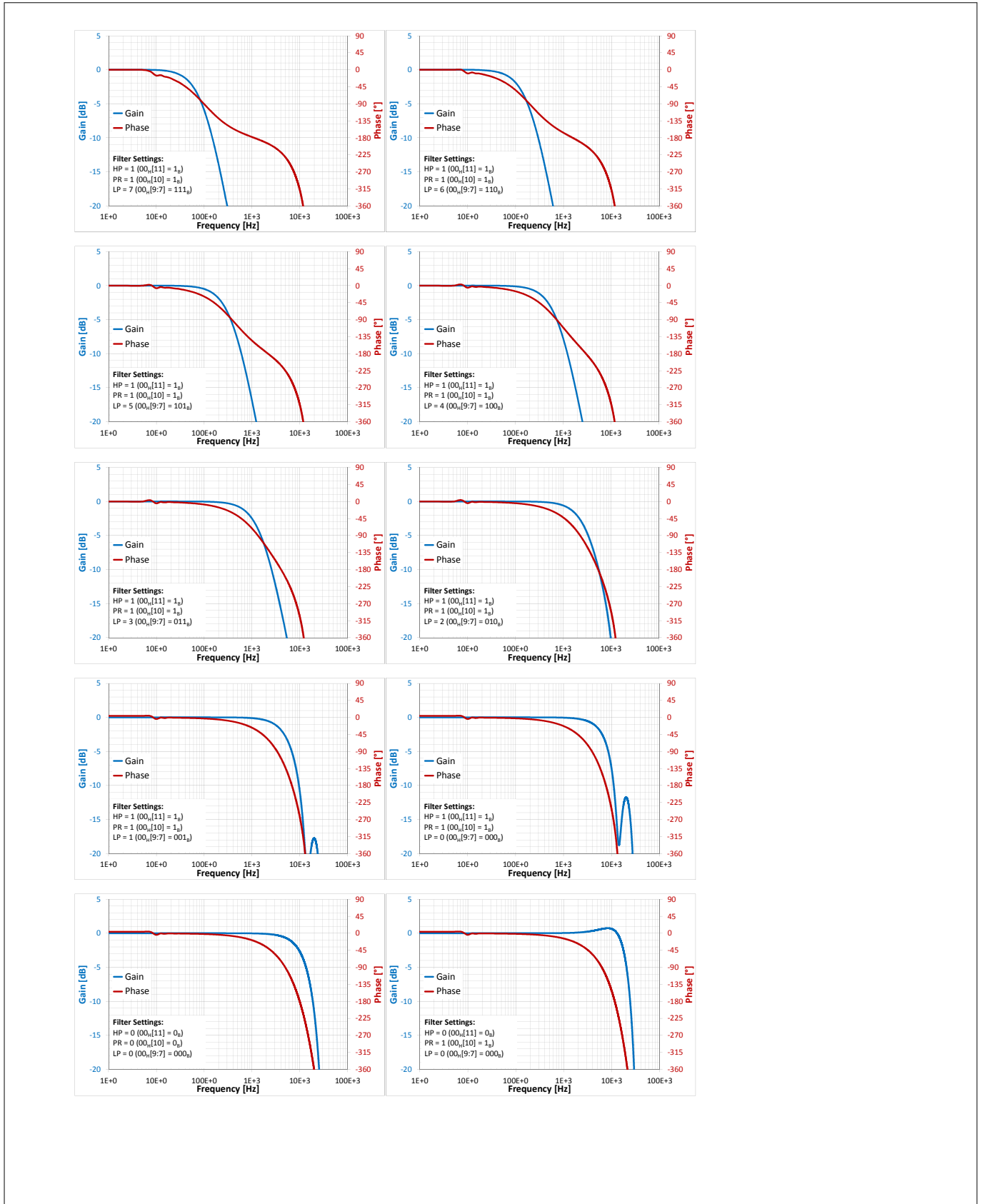

Figure 5 Bode plots for different filter settings

2 Functional Description**2.6 Increased Temperature Range**

The max. specified ambient operating temperature of 85°C is limited due to the power dissipation in the current rail. The thermal loss finally increases the junction temperature which has to be limited to 125°C.

Reducing the current through the current rail decreases the thermal loss and therewith a higher ambient operating temperature is possible.

3 Specification

3 Specification

3.1 Absolute Maximum Ratings

Table 4 Absolute Maximum Ratings

General conditions (unless otherwise specified): $V_{DD} = 3.3\text{ V}$; $T_A = -40\text{ °C} \dots +85\text{ °C}$

Parameter	Symbol	Values			Unit	Note or Test Condition
		Min.	Typ.	Max.		
Supply voltage	V_{DD}	-0.3	-	+3.6	V	
Maximum primary current	I_P	-60	-	+60	A	$T_A = T_{\text{Contact_IP_IN}}$ ²⁾
Maximum primary pulse current	I_{P_PULSE}	-	-	150	A	Max. 3 pulses, 200 ms each; tested with 105 μm Cu layer on PCB
Voltage on interface pins DOUT, SCLK & OCD	V_{IO}	-0.3	-	+3.6	V	
Voltage on interface pin $\overline{\text{CS}}$	V_{IO_CS}	-0.3	-	+21.0	V	
ESD voltage ³⁾	V_{ESD_HBM}	-	-	± 2	kV	
Maximum junction temperature	T_{J_max}	-	-	+125	°C	
Storage temperature	T_{A_STORE}	-40	-	+125	°C	Not connected

Attention: Stresses above the limit values listed here may cause permanent damage to the device. Exposure to absolute maximum rating conditions for extended periods may affect device reliability. Maximum ratings are absolute ratings; exceeding only one of these values may cause irreversible damage to the integrated circuit.

3.2 Operating Conditions

Table 5 Electrical Operating Parameters

General conditions (unless otherwise specified): $V_{DD} = 3.3\text{ V}$; $T_A = -40\text{ °C} \dots +85\text{ °C}$

Parameter	Symbol	Values			Unit	Note or Test Condition
		Min.	Typ.	Max.		
Supply voltage	V_{DD}	3.1	3.3	+3.5	V	
Voltage on interface pin $\overline{\text{CS}}$	V_{IO_CS}	-0.3	-	+3.6	V	Normal operation
	V_{IO_PROG}	+20.5	-	+20.7	V	Only during programming
Current consumption	I_{DD}	5	12	20	mA	Secondary side

²⁾ $T_{\text{Contact_IP_IN}}$: Temperature of current rail on PCB at solder joint.

3 Specification

Table 5 Electrical Operating Parameters (continued)

General conditions (unless otherwise specified): $V_{DD} = 3.3\text{ V}$; $T_A = -40\text{ °C} \dots +85\text{ °C}$

Parameter	Symbol	Values			Unit	Note or Test Condition
		Min.	Typ.	Max.		
Full-scale primary current measurement range	I_{PFSR}	-50	-	+50	A	
Primary resistance	R_P	-	0.6	-	mΩ	Resistance of current rail $T_A = 25\text{ °C}$ T_{J_max}
		-	-	1.0	mΩ	
Ambient temperature	T_A	-40	-	+85	°C	$T_A = T_{Contact_IP_IN}$ ⁴⁾

Table 6 Accuracy Parameters

General conditions (unless otherwise specified): $V_{DD} = 3.3\text{ V}$; $T_A = -40\text{ °C} \dots +85\text{ °C}$

Parameter	Symbol	Values			Unit	Note or Test Condition
		Min.	Typ.	Max.		
Relative offset error	ϵ_{ROE}	-0.05	-	+0.05	% of	@ 0A DC & $T_A = 25\text{ °C}$ @ 0A DC & $T_A = -40\text{ °C}$ @ 0A DC & $T_A = 85\text{ °C}$
		-0.075	-	+0.075	I_{PFSR}	
		-0.15	-	+0.15	% of	
					I_{PFSR}	
Absolute offset error	ϵ_{AOE}	-25.0	-	+25.0	mA	@ 0A DC & $T_A = 25\text{ °C}$ @ 0A DC & $T_A = -40\text{ °C}$ @ 0A DC & $T_A = 85\text{ °C}$
		-37.5	-	+37.5	mA	
		-75.0	-	+75.0	mA	
Relative total error (gain, offset, linearity) incl. lifetime-drift and whole temperature range ⁵⁾	ϵ_{RTE}	-3.5	-	+3.5	% of I_P	Percentage of indicated value
Absolute total error (gain, offset, linearity) incl. lifetime-drift and whole temperature range ⁵⁾	ϵ_{ATE}	-35.0	-	+35.0	mA/A	Absolute total error proportional to I_P
Update rate	f_{UPDATE}	-	80	-	kSPS ⁶⁾	
Resolution	G	-	12.5	-	mA / LSB	13-Bit current value via SPI

³ According to standard EIA / JESD22-A114-E Human Body Model (HBM)

⁴ $T_{Contact_IP_IN}$: Temperature of current rail on PCB at solder joint.

⁵ Valid for soldered parts on PCB based on the footprint recommendation in **Figure 14** and a copper thickness of 70 μm

⁶ kSPS: Thousand samples per second

3 Specification

Table 6 Accuracy Parameters (continued)

General conditions (unless otherwise specified): $V_{DD} = 3.3\text{ V}$; $T_A = -40\text{ °C} \dots +85\text{ °C}$

Parameter	Symbol	Values			Unit	Note or Test Condition
		Min.	Typ.	Max.		
Noise ⁷⁾	I_{NOISE}	-	10	-	mA_{RMS}	@ $T_A = 25\text{ °C}$ & $BW_I = 1.1\text{ kHz}$ ⁸⁾
Bandwidth of current measurement path	BW_{I_min}	-	70	-	Hz	-3 dB cutoff; see Chapter 2.5 for filter settings
	BW_{I_max}	-	18	-	kHz	
Power-on time		-	-	15	ms	To stable and accurate output data

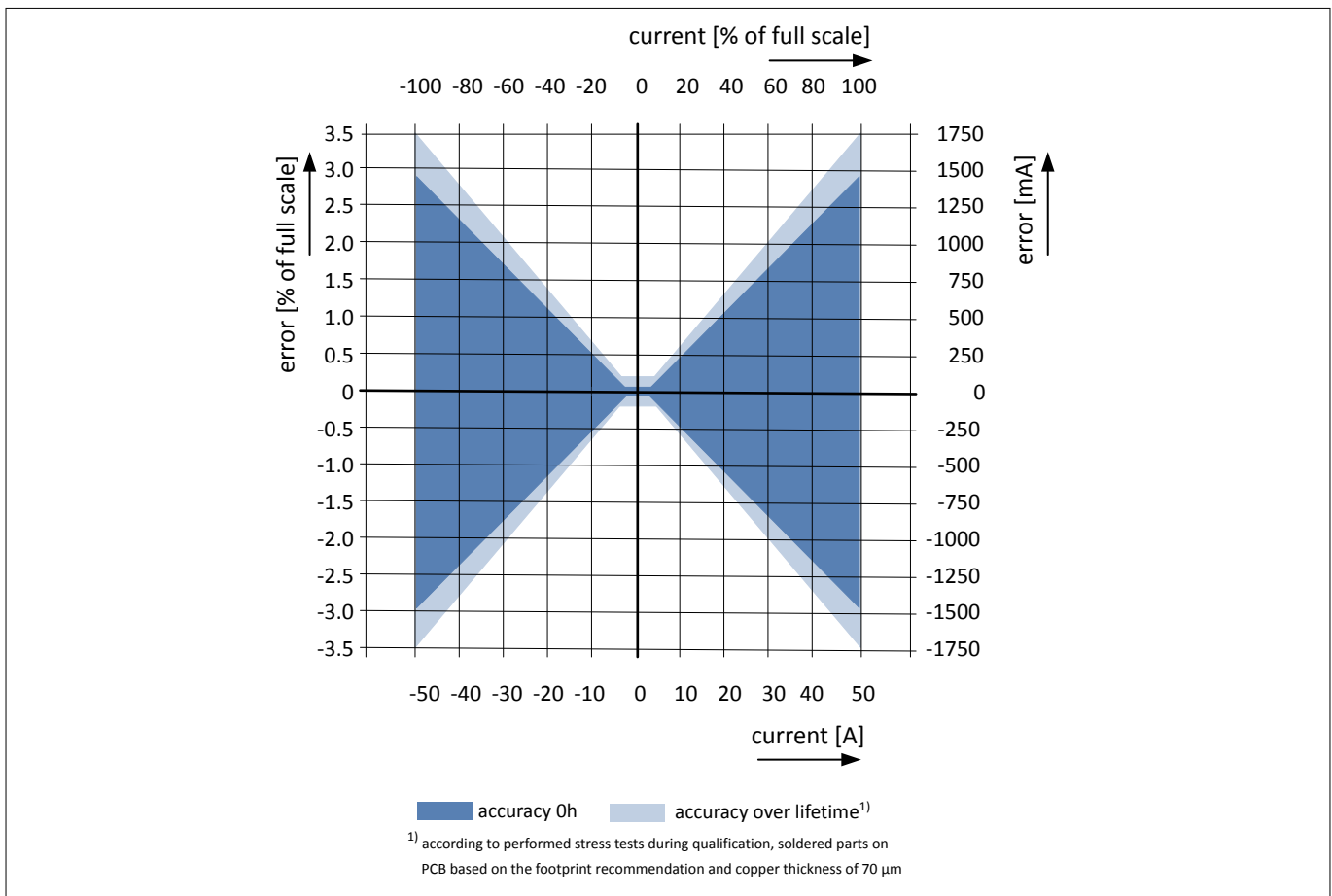

Figure 6 Distribution of the maximum total error

⁷ Characterized in the laboratory for small signals; $I_P = 0\text{ mA}$

⁸ Bandwidth settings will affect noise

3 Specification

3.3 Fast Over Current Output

The Fast Over Current (OCD) pin allows fast detection of an over current in the measurement path. The OCD signal path is independent from the bandwidth limited current signal path and has a programmable glitch filter to avoid false triggers by noise spikes on the current rail. The symmetric threshold level of the OCD output is adjustable and triggers an over current event in case of a positive or negative over current.

In addition a zero-crossing functionality can be programmed (in this case the over current detection is disabled).

If connected via an external pull-up resistor to a logic input pin of the microcontroller, it can be used to trigger an interrupt in the microcontroller and quickly shut off the system to avoid damage from the over current event. The OCD pin has an open-drain output that allows monitoring of several current sensors via only one microcontroller input pin. For details, please refer to the application circuit shown in [Figure 7](#).

The instruction for the settings can be found in the TLI4970 programming guide.

Table 7 **OCD Output Parameter**

General conditions (unless otherwise specified): $V_{DD} = 3.3\text{ V}$; $T_A = -40\text{ °C} \dots +85\text{ °C}$

Parameter	Symbol	Values			Unit	Note or Test Condition
		Min.	Typ.	Max.		
Threshold level ⁹⁾	I_{THR}	3	-	90	A	Programmable (EEPROM). Default factory value 30A.
Accuracy	X_{OCD}	-	10	-	% I_{PFSR}	
Response time of fast over current detection ¹⁰⁾¹¹⁾	t_{D_OC}	-	1.8	3.5	μs	Only valid for $\Delta I/\Delta t < 500\text{ kA/s}$
Load capacitance	C_L	-	-	1	nF	To GND
Open-drain current	I_{OD_on}	-	-	1	mA	Resistive to V_{DD} ; $V_{OD_on} \leq 0.2 \times V_{DD}$
Pull-up resistor	R_{PU}	4.7	-	-	k Ω	To V_{DD}
De-glitch filter time	$t_{deglitch}$	-	750	-	ns	Default factory value

⁹ Symmetric threshold level for positive and negative currents

¹⁰ Falling edge level of OCD-pin $< 0,5V_{DD}$

¹¹ Characterized in lab under worst case test conditions: $R_{PU} = 4.7\text{k}\Omega$ to V_{DD} ; $C_L = 1\text{ nF}$ to GND

3 Specification

3.4 Application Circuit

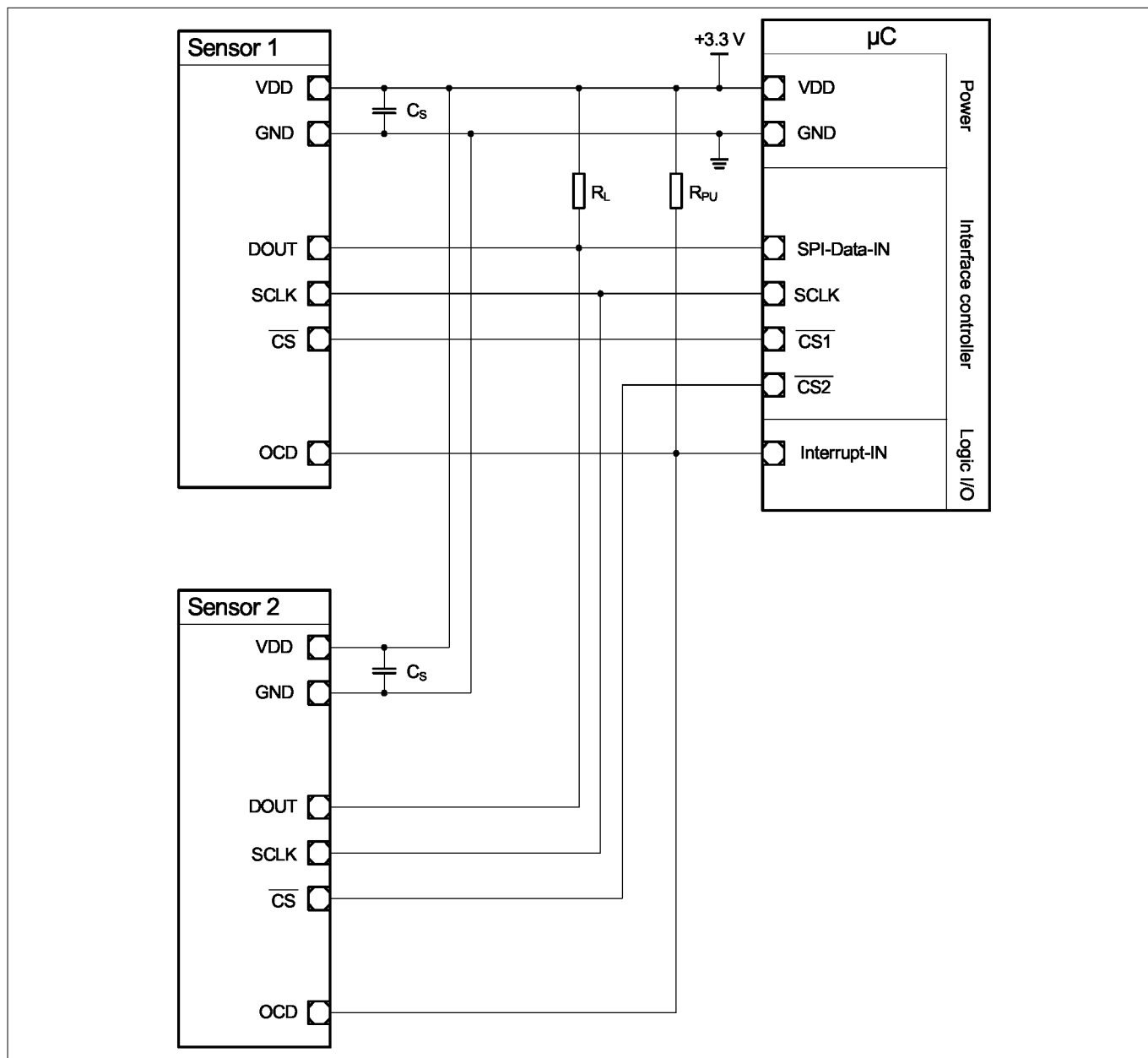

Figure 7 Application circuit for readout of multiple sensors in parallel bus mode

Table 8 Typical Application Values

Name	Value
R_{PU}	47 k Ω
R_L	100 k Ω
C_S	100 nF

3 Specification

3.5 Isolation Characteristics

The TLI4970-D050T5 is qualified and tested according IEC and UL standards (functional isolation).

Table 9 Isolation Parameters according to IEC 60747-5-2

Description	Symbol	Characteristic	Unit
Maximum rated working voltage (AC & DC-voltage) ¹²⁾¹³⁾¹⁴⁾	U_{IOWM}	330	V
Maximum repetitive isolation voltage (max. AC & DC-voltage) ¹²⁾¹⁴⁾	U_{IORM}	330	V_{peak}
Apparent charge test voltage (Method B) ¹²⁾¹⁴⁾¹⁵⁾ Partial discharge < 5pC	$U_{pd,b}$	900	V_{peak}
Isolation test voltage (1 sec) ¹²⁾	U_{ISO}	2546	V_{RMS}
Maximum surge voltage (1.2 / 50 μ s) ¹²⁾	U_{IOSM}	3600	V_{peak}
Minimum external creepage distance	CPG	3.0	mm
Minimum external clearance distance	CLR	3.0	mm
Minimum comparative tracking index	CTI	575 (Material group II)	
Isolation resistance, $U_{IO} = 500$ V ¹⁶⁾	R_{IO}	$> 10^{10}$	Ω

Table 10 Isolation Parameters according to UL 1577

Description	Symbol	Characteristic	Unit
Maximum rated isolation voltage (1 min.)	U_{ISO}	2546	V_{RMS}
Isolation test voltage (1 sec)	U_{ISO}	2546	V_{RMS}

¹²⁾ Refer to IEC 60747-5-2 for a detailed description of voltages and partial discharge tests

¹³⁾ The given value is just an example based on pollution degree 2

¹⁴⁾ According to performed stress test (85°C, 85% relative humidity, 1000 h test time & 600 V applied insulation voltage)

¹⁵⁾ Tested with 50 Hz at room temperature

¹⁶⁾ Not subject to production test - verified by design/characterization

3 Specification

3.6 CSA Component Acceptance

The following section describes the test condition for the CSA component acceptance.

Table 11 Absolute maximum ratings according to CSA component acceptance

Description	Symbol	Characteristic	Unit
Absolute maximum ambient temperature	T_{A_CA}	85	°C
Absolute maximum Isolation voltage ¹⁷⁾	U_{ISO_CA}	2546	V_{RMS}
Absolute maximum current ¹⁸⁾	I_{PFSR_CA}	50	A ¹⁹⁾

3.6.1 Board Description for CSA Component Acceptance Test Conditions

The device was soldered on a test board described in [Figure 9](#) and [Table 12](#). Besides, a heat sink was mounted [Figure 8](#).

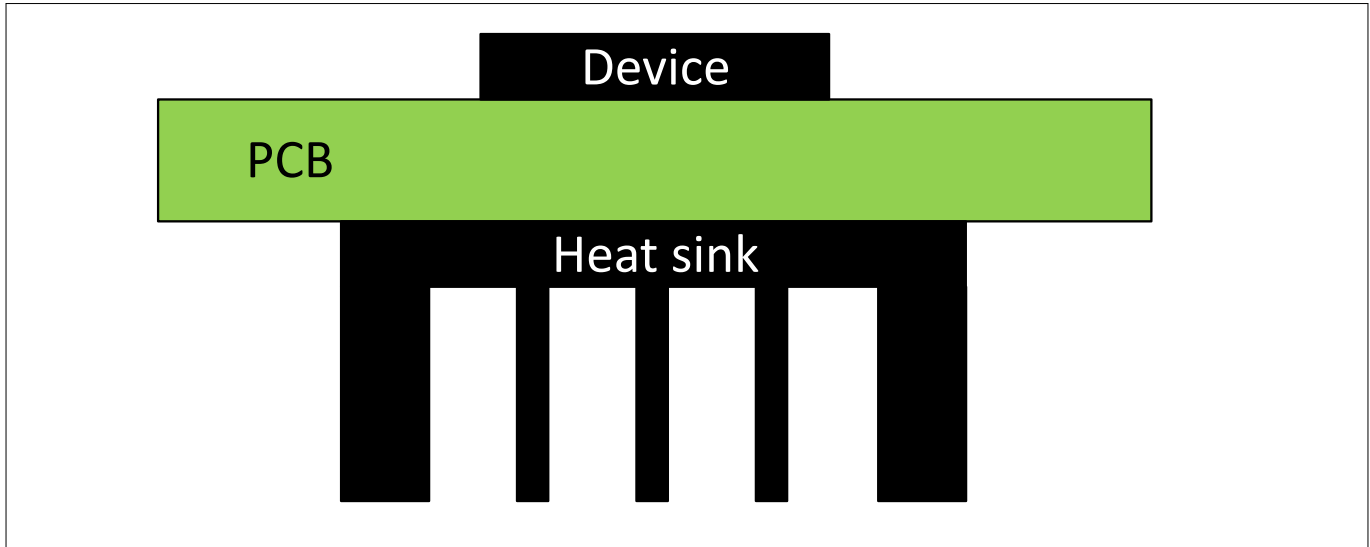

Figure 8 Test board setting

Table 12 Test board parameters

Description	Value
Dimension	85 mm x 36 mm
PCB material	FR4
PCB thickness	1.55 μm
No. of copper layers	4
Thickness of each copper layer	105 μm

¹⁷ Test conditions: 60 Hz for 60 s

¹⁸ Test condition: 4h, the device was mounted on the PCB described below

¹⁹ rms or DC

3 Specification

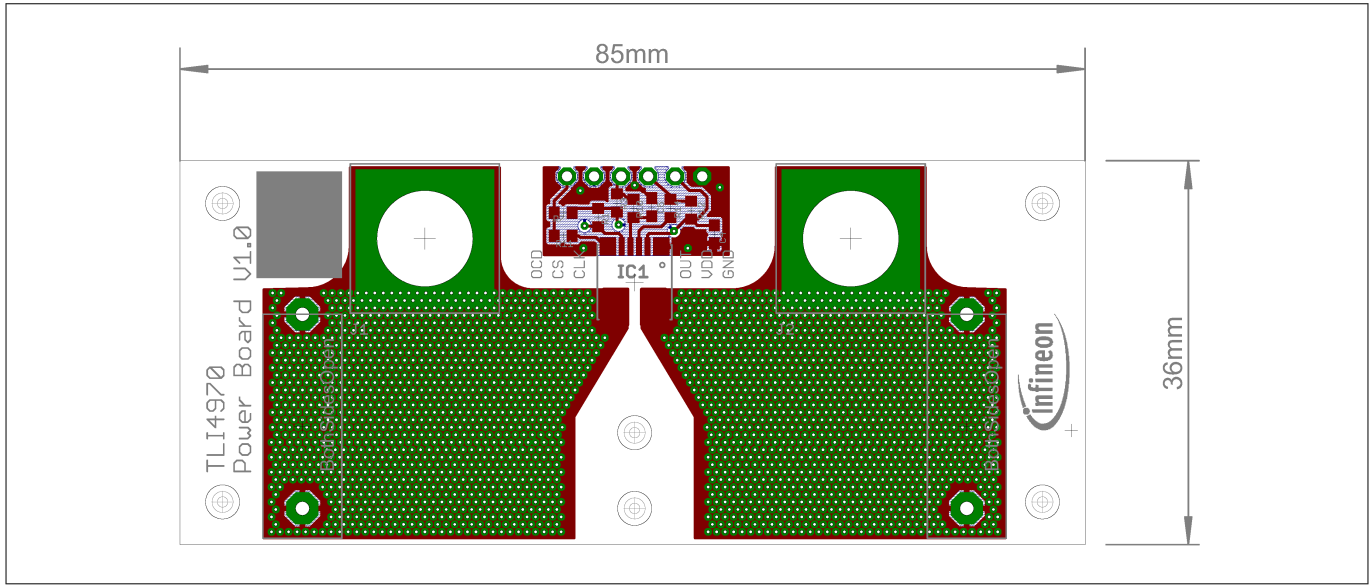

Figure 9 Dimension and layout of test board

In [Table 13](#) and [Figure 10](#) the used heat sink is described.

Table 13 Heat sink parameters

Description	Value
Type	SK68
Manufacturer	Fischer Elektronik
Dimension	33 mm x 46 mm x 50 mm
Thermal resistance	4.8 K/W

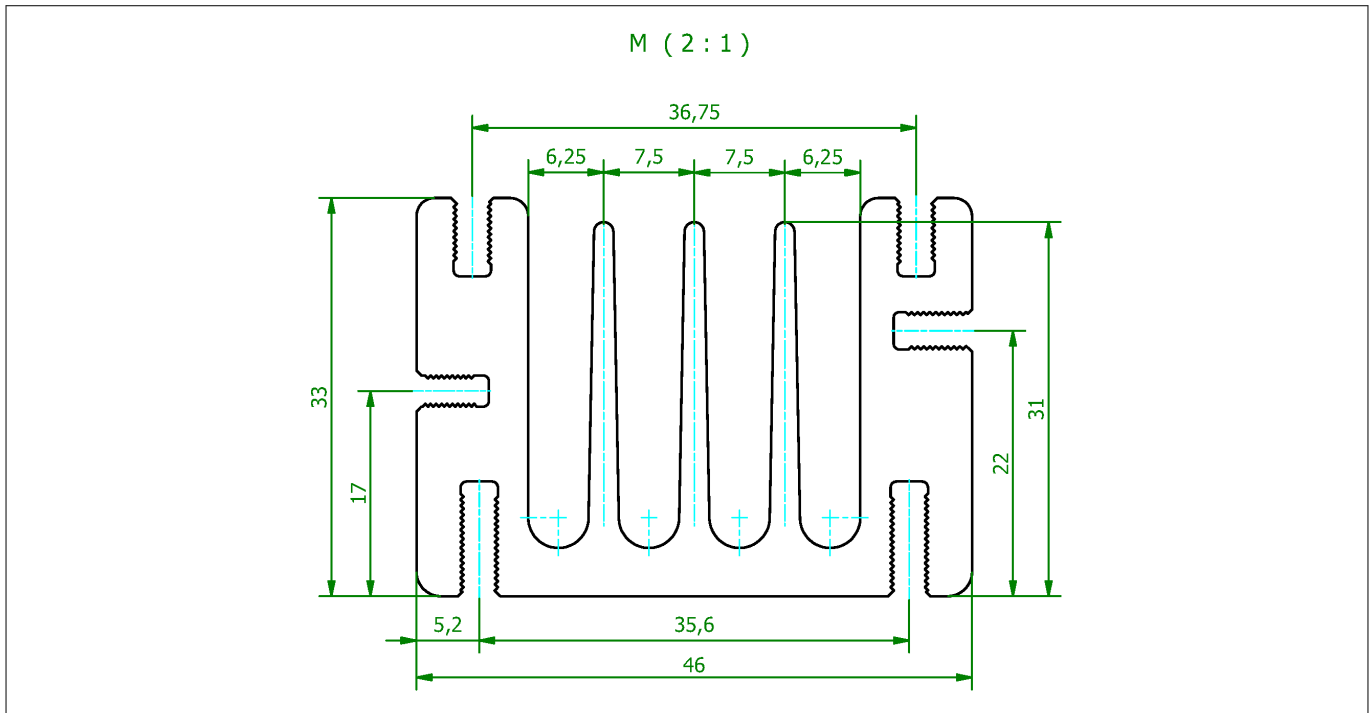

Figure 10 Heat sink dimension (in mm)

4 Interfaces

4 Interfaces

4.1 SPI Interface Definition

The TLI4970-D050T5 has a 3-pin serial peripheral interface (SPI). A standard unidirectional 16-bit SPI protocol is used. Several sensors can be connected to a parallel SPI bus. An example on how to connect multiple sensors is given in [Figure 7](#). The timing parameters are given in [Table 14](#).

4.1.1 Logical Interface

All SPI frames are based on a 16-bit word. A parity bit in each SPI frame allows the detection of transmission errors and increases the reliability of the measured data. The transmission of the data is triggered by the \overline{CS} -pin.

4.1.1.1 Protocol Description

The internal data register is continuously updated with the internal update rate f_{UPDATE} . When \overline{CS} is pulled to low, the actual value from the data register is written into the SPI output register. Like in standard SPI protocol, the sensor starts to transmit the data when clock pulses are applied to the SCLK pin and the \overline{CS} -pin is still low. With the next 16 clock pulses, the data word is sent out via the DOUT pin. If more than 16 clock pulses are sent by the SPI-Master and the \overline{CS} -pin stays low, the sensor sends 0's for all additional clock pulses. If a new sample should be read from the sensor, the \overline{CS} -pin has to return to the high state for at least the time t_{CSON} before pulling it to low again in order to trigger the next sample readout.

The clock pulses are ignored and the DOUT pin is in high ohmic state, when the \overline{CS} -pin is in "high" state. Therefore multiple chips can be readout on the same data bus by sequentially selecting the addressed sensor via the \overline{CS} -pin.

4.1.1.2 Description of the SPI Data Frames

There are two different types of SPI frames sent from the sensor. The "Sensor Status Message" and the "Sensor Value Message". The two types are distinguished by the STATUS Bit. The DATA section contains different information. For details see below.

4.1.1.2.1 General structure of the 16-bit SPI data frame

VALUE	Address:	00 _H
Value of the actual current measurement	Reset value:	4000 _H

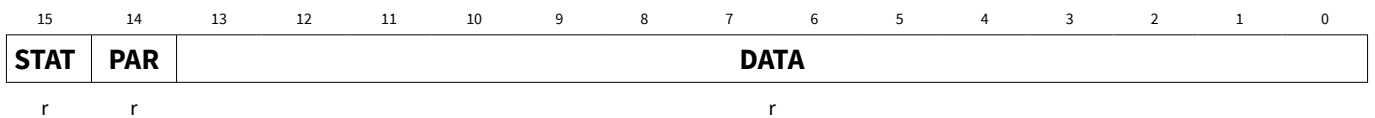

Field	Bits	Type	Description
STAT	15	r	Status Status identifier.
PAR	14	r	Parity Bit Odd parity of current value.
DATA	13:0	r	Data

4 Interfaces

(continued)

Field	Bits	Type	Description
			Data field.

4.1.1.3 Sensor Current Message

The actual measurement current value is returned in the Sensor Value Message.

4.1.1.3.1 Structure of the Sensor Value Message

VALUE	Address:	01 _H
Value of the actual current measurement	Reset value:	4000 _H

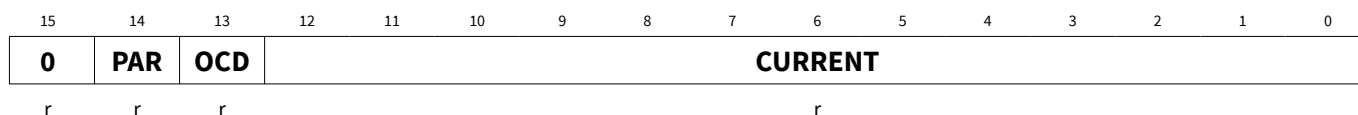

Field	Bits	Type	Description
0	15	r	Status Status identifier of a Sensor Value Word
PAR	14	r	Parity Bit Odd parity of current value. This bit is set in a way that the sum of all bits in the Value Word is odd.
OCD	13	r	OCD-state Over current comparator value 0 _B No over current 1 _B Over current detected
CURRENT	12:0	r	Current value Actual measured current value.

4.1.1.4 Sensor Status Message

The Sensor Status Word contains information about temperature and load conditions and is sent under the following conditions:

- Once after start-up (“Sensor restarted”)
- During the sensor start-up phase when a command is sent (“Sensor busy”)
- If an internal error occurred (“Sensor fail”)

4.1.1.4.1 Structure of the Sensor Status Message

STATUS	Address:	02 _H
Sensor status message	Reset value:	8000 _H

4 Interfaces

15	14	13	12	11	10	9	8	7	6	5	4	3	2	1	0
1	PAR	HW	OL	OT	COM	RESERVED									
r	r	r	r	r	r	r									

Field	Bits	Type	Description
1	15	r	Status Status identifier of a Sensor Status Word
PAR	14	r	Parity Bit Odd parity of current value. This bit is set in a way that the sum of all bits in the Status Word is odd.
HW	13	r	Hardware error 0 _B OK 1 _B Internal error; sensor not usable
OL	12	r	Overload error 0 _B OK 1 _B Overload (Current outside I _{PFSR} range)
OT	11	r	Temperature error 0 _B OK 1 _B Temperature out of range
COM	10	r	Communication error 0 _B OK 1 _B No multiple of 16 SCLK cycles detected in last frame
RESERVED	9:0	r	Reserved Don't care - Reserved for future use

4.1.2 Physical SPI Interface

The TLI4970-D050T5 has a 3-pin unidirectional SPI interface. This interface can be driven with a clock up to 5 MHz. The timing parameters are given in [Table 14](#). Electrical characteristics are given in [Table 15](#).

4 Interfaces

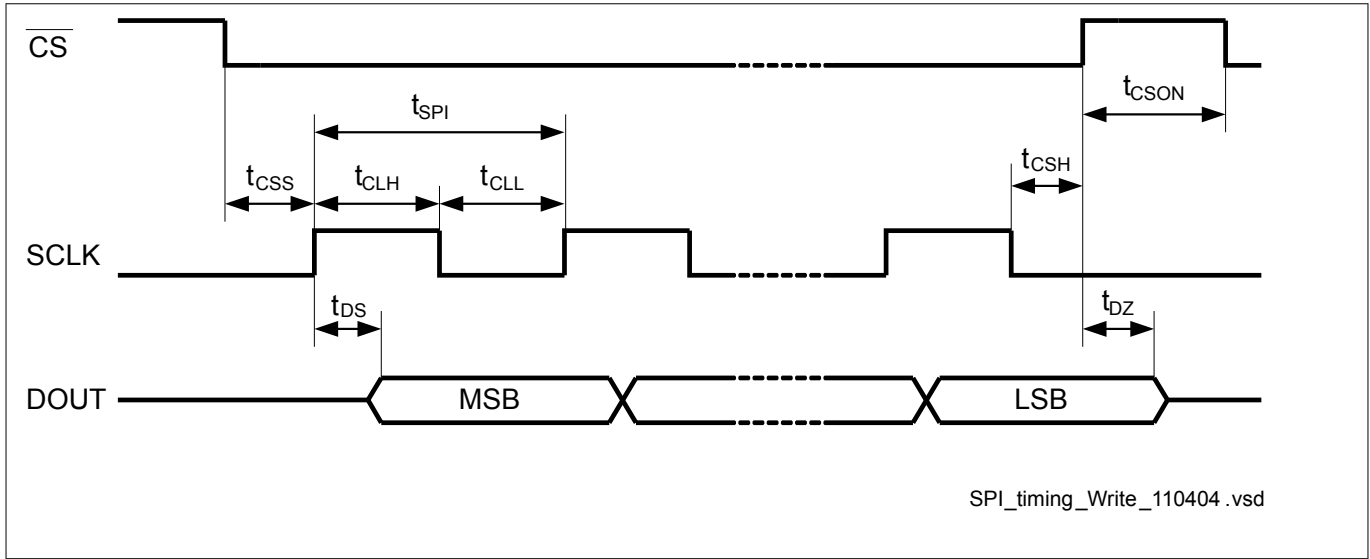

Figure 11 SPI interface timing: Readout of sensor data

Table 14 Interface Timing Parameters (5 MHz SPI clock speed)

General conditions (unless otherwise specified): $V_{DD} = 3.3\text{ V}$; $T_A = -40\text{ }^\circ\text{C} \dots +85\text{ }^\circ\text{C}$

Parameter	Symbol	Values			Unit	Note or Test Condition
		Min.	Typ.	Max.		
SPI speed (1 / bit time)	f_{SPI}	-	-	5	MHz	Duty cycle ratio 45% ... 55%
SPI period	t_{SPL}	200	-	-	ns	
SCLK duty cycle	t_{CLH} / t_{CLL}	45	-	55	%	
\overline{CS} setup time	t_{CSS}	95	-	-	ns	$R_L \geq 100\text{ k}\Omega$ $C_L \leq 50\text{ pF}$ to GND
\overline{CS} hold time	t_{CSH}	95	-	-	ns	$R_L \geq 100\text{ k}\Omega$ $C_L \leq 50\text{ pF}$ to GND
Data setup time	t_{DS}	-	-	65	ns	
Delay between \overline{CS} rising edge and end of DOUT data	t_{DZ}	-	-	75	ns	
\overline{CS} high time	t_{CSO}	300	-	-	ns	

Note: All timing parameters are valid on the sensor pin with the specified test load only. Different loading due to PCB mounting might result in different timing.

Table 15 Interface Electrical Characteristics (5 MHz SPI clock speed)

General conditions (unless otherwise specified): $V_{DD} = 3.3\text{ V}$; $T_A = -40\text{ }^\circ\text{C} \dots +85\text{ }^\circ\text{C}$

Parameter	Symbol	Values			Unit	Note or Test Condition
		Min.	Typ.	Max.		
Output level low (SPI)	V_{OL}	-	-	$0.2 \times V_{DD}$	V	Resistive load; 1 mA to GND

4 Interfaces

Table 15 **Interface Electrical Characteristics (5 MHz SPI clock speed) (continued)**

General conditions (unless otherwise specified): $V_{DD} = 3.3\text{ V}$; $T_A = -40\text{ °C} \dots +85\text{ °C}$

Parameter	Symbol	Values			Unit	Note or Test Condition
		Min.	Typ.	Max.		
Output level high (SPI)	V_{OH}	$0.8 \times V_{DD}$	-	-	V	Resistive load; 1 mA to GND
Input level low (SPI)	V_{IL}	-0.1	-	$0.3 \times V_{DD}$	V	
Input level high (SPI)	V_{IH}	$0.7 \times V_{DD}$	-	V_{DD}	V	
Input level hysteresis (SPI)		$0.05 \times V_{DD}$	-	-	V	
Input capacitance	C_I	-	-	100	pF	For all digital input pins
Input resistance	R_I	100	-	-	k Ω	For all digital input pins
Load capacitance	C_L	-	-	50	pF	To GND; For all digital output pins
Load resistance	R_L	100	-	-	k Ω	To VDD; For all digital output pins

4.2 Serial Inspection and Configuration Interface (SICI)

The serial inspection and configuration interface is only used for EEPROM programming. This interface is a one wire interface provided by a double seizure of the OCD pin. To guarantee a proper SICI communication current must not flow through the primary conductor (to avoid interferences with potential over current detection). The instruction for the serial inspection and configuration interface can be found in the TLI4970 programming guide.

5 Package

5.2 Packing

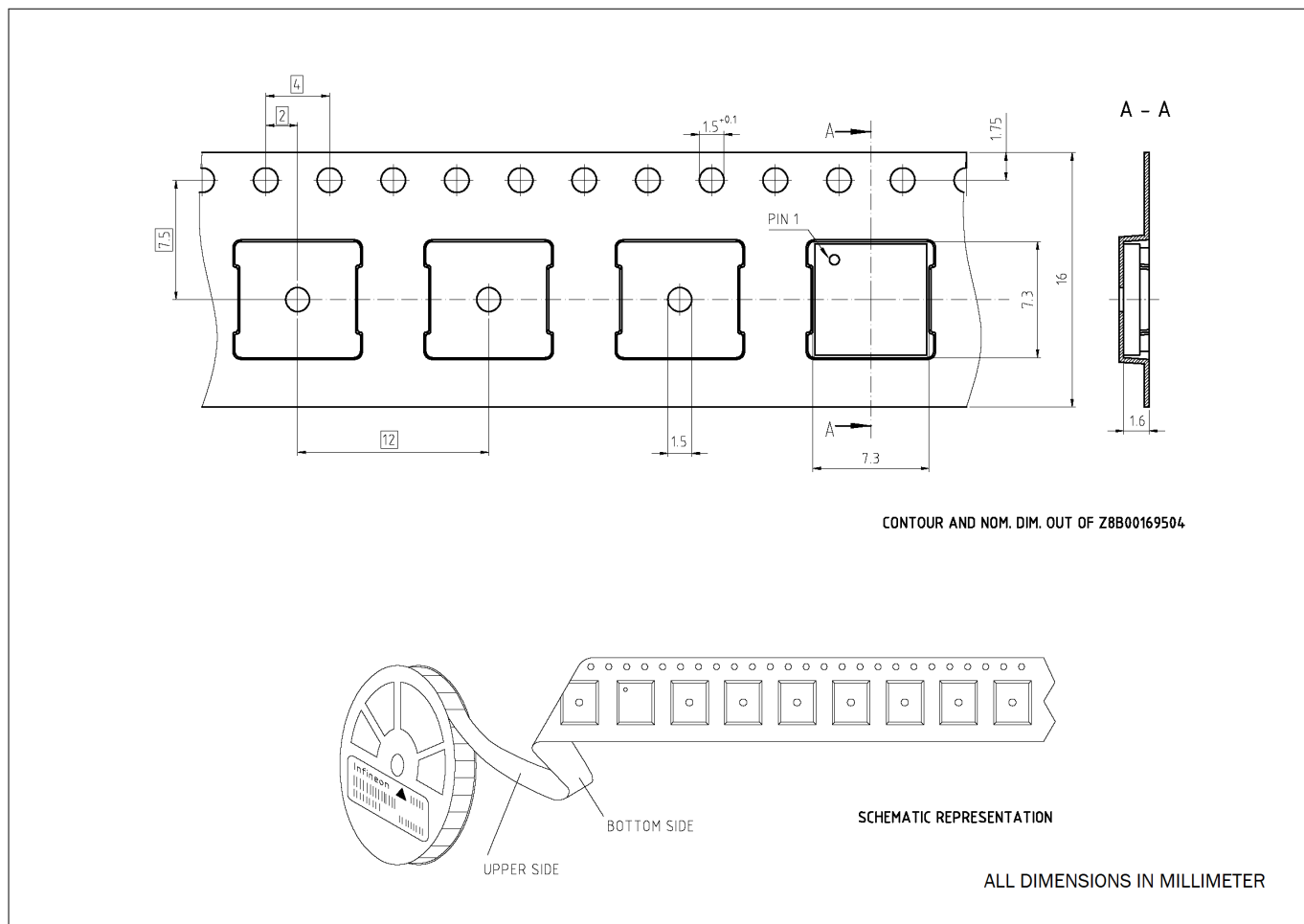

Figure 13 Carrier tape of the PG-TISON-8-1 package

5 Package

5.3 Footprint Recommendation

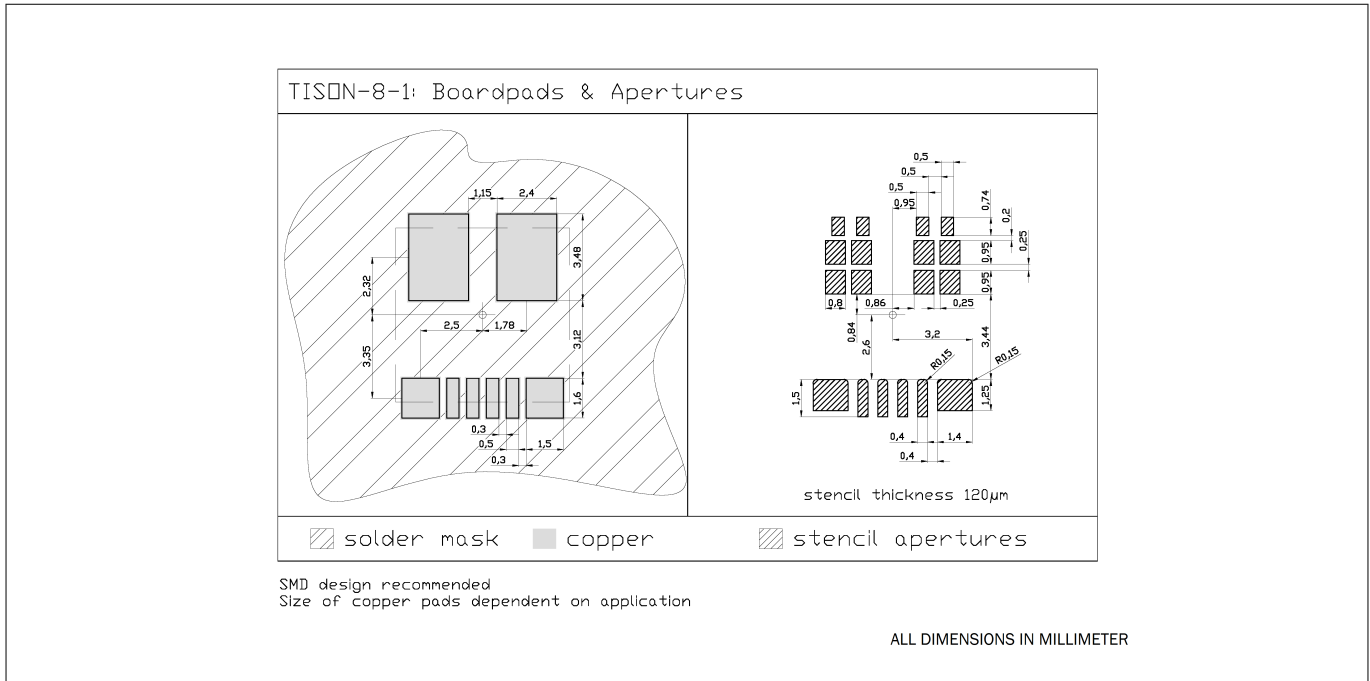

Figure 14 Footprint recommendation for reflow soldering

5.4 PCB Layout Recommendation

The PCB layout recommendation shown in [Chapter 5.4](#) leads to the preferred current flow through the housing to achieve the highest accuracy.

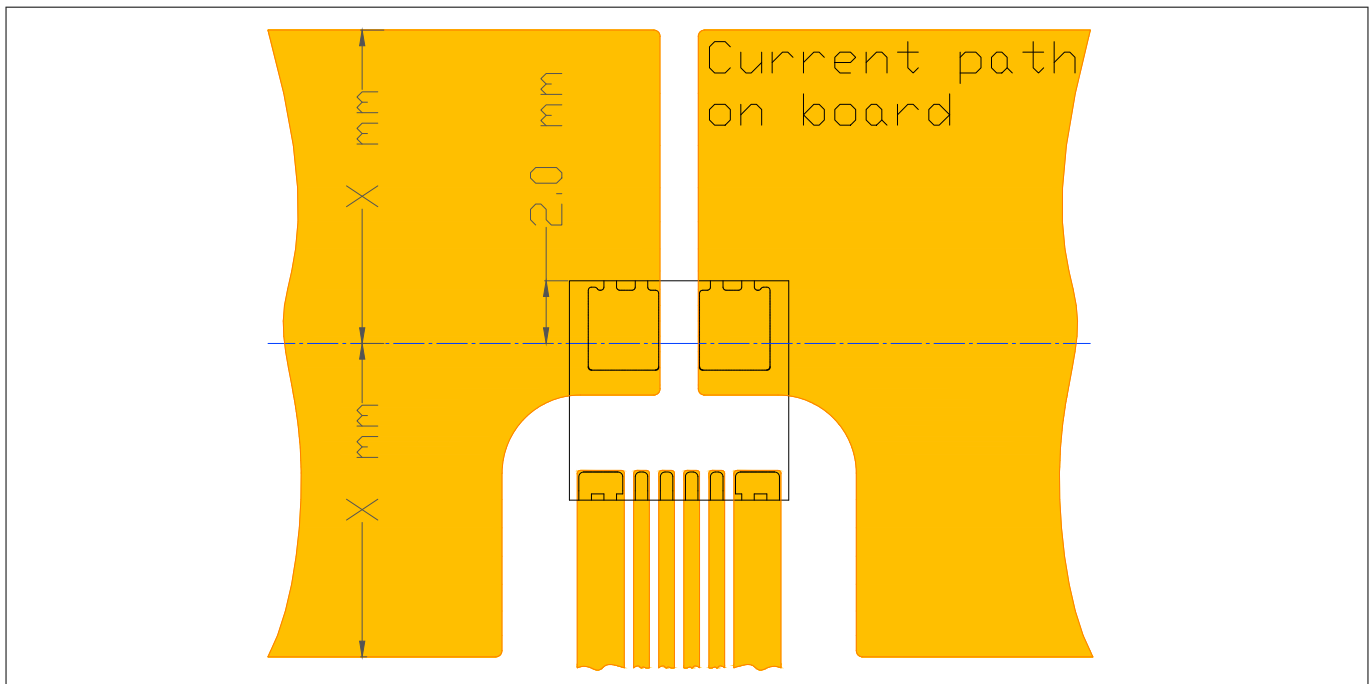

Figure 15 PCB layout recommendation

5 Package

5.5 Laser Marking

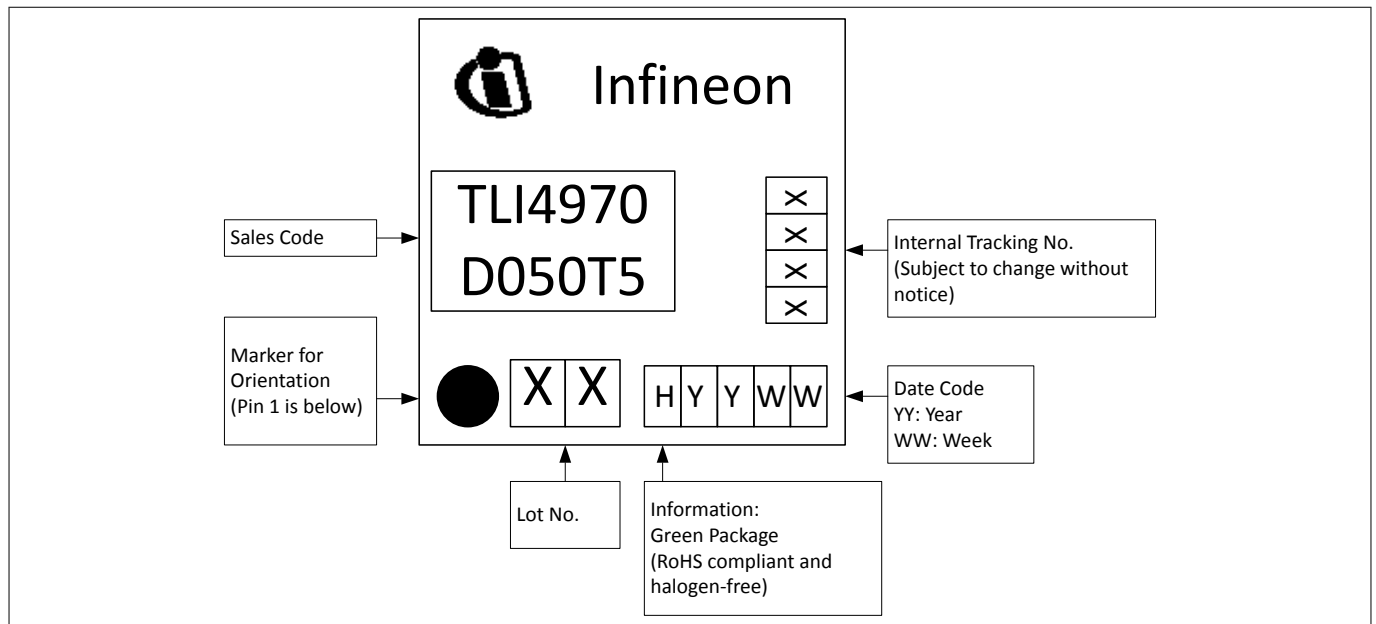

Figure 16 Laser marking on the top side

6 Revision History

6 Revision History

Revision History

Page or Item	Subjects (major changes since previous revision)
Rev. 1.2, 2019-03-21	
19	Table 9, Isolation Parameters according to IEC 60747-5-2 updated
Rev. 1.1, 2016-06-17	
20	Chapter 3.6 on page 20 added
11	Added note on default bandwidth.
17	Table 7 updated: Added row for De-glitch filter time. Added note on default OCD level.

Trademarks

All referenced product or service names and trademarks are the property of their respective owners.

Edition 2019-03-19

**Published by
Infineon Technologies AG
81726 Munich, Germany**

**© 2019 Infineon Technologies AG
All Rights Reserved.**

**Do you have a question about any
aspect of this document?
Email: erratum@infineon.com**

**Document reference
IFX-jsf1558695499786**

IMPORTANT NOTICE

The information given in this document shall in no event be regarded as a guarantee of conditions or characteristics ("Beschaffheitsgarantie").

With respect to any examples, hints or any typical values stated herein and/or any information regarding the application of the product, Infineon Technologies hereby disclaims any and all warranties and liabilities of any kind, including without limitation warranties of non-infringement of intellectual property rights of any third party.

In addition, any information given in this document is subject to customer's compliance with its obligations stated in this document and any applicable legal requirements, norms and standards concerning customer's products and any use of the product of Infineon Technologies in customer's applications.

The data contained in this document is exclusively intended for technically trained staff. It is the responsibility of customer's technical departments to evaluate the suitability of the product for the intended application and the completeness of the product information given in this document with respect to such application.

WARNINGS

Due to technical requirements products may contain dangerous substances. For information on the types in question please contact your nearest Infineon Technologies office.

Except as otherwise explicitly approved by Infineon Technologies in a written document signed by authorized representatives of Infineon Technologies, Infineon Technologies' products may not be used in any applications where a failure of the product or any consequences of the use thereof can reasonably be expected to result in personal injury