

Ultra-Small, Ultra-Low Power MEMS Oscillator

Features

- Wide Frequency Range: 2 kHz to 100 MHz
- Ultra-Low Power Consumption: 3 mA/12 μ A (Active/Standby)
- Ultra-Small Footprints
 - 1.6 mm \times 1.2 mm
 - 2.0 mm \times 1.6 mm
 - 2.5 mm \times 2.0 mm
 - 3.2 mm \times 2.5 mm
- Frequency Select Input Supports Two Pre-Defined Frequencies
- High Stability: ± 25 ppm, ± 50 ppm
- Wide Temperature Range
 - Industrial: -40°C to 85°C
 - Ext. Commercial: -20° to 70°C
- Excellent Shock and Vibration Immunity
 - Qualified to MIL-STD-883
- High Reliability
 - 20x Better MTF Than Quartz Oscillators
- Supply Range of 1.71V to 3.63V
- Short Sample Lead Time: <2 weeks
- Lead Free & RoHS Compliant

Applications

- Low Power/Portable Applications: IoT, Embedded/Smart Devices
- Consumer: Home Healthcare, Fitness Devices, Home Automation
- Automotive: Rear View/Surround View Cameras, Infotainment System
- Industrial: Building/Factory Automation, Surveillance Camera

General Description

The DSC61xx family of MEMS oscillators combines the industry leading low power consumption and ultra-small packages with exceptional frequency stability and jitter performance over temperature. The single-output DSC61xx MEMS oscillators are excellent choices for use as clock references in small, battery-powered devices such as wearable and Internet of Things (IoT) devices in which small size, low power consumption, and long-term reliability are paramount. They also meet the stringent mechanical durability and reliability requirements within Automotive Electronics Council standard Q100 (AEC-Q100), so they are well suited for under-hood applications as well.

The DSC61xx family is available in ultra-small 1.6 mm \times 1.2 mm and 2.0 mm \times 1.6 mm packages. Other package sizes include: 2.5 mm \times 2.0 mm and 3.2 mm \times 2.5 mm. These packages are “drop-in” replacements for standard 4-pin CMOS quartz crystal oscillators.

Package Types

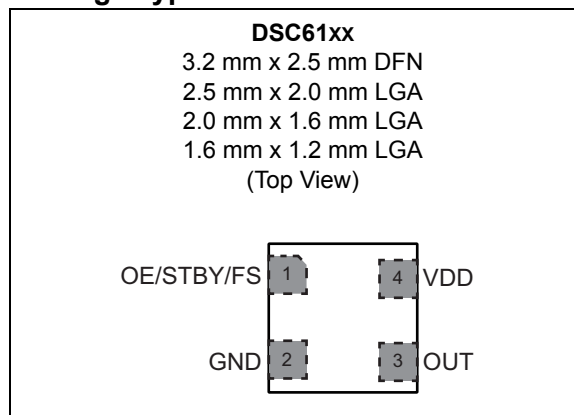

DSC61XX

Block Diagram

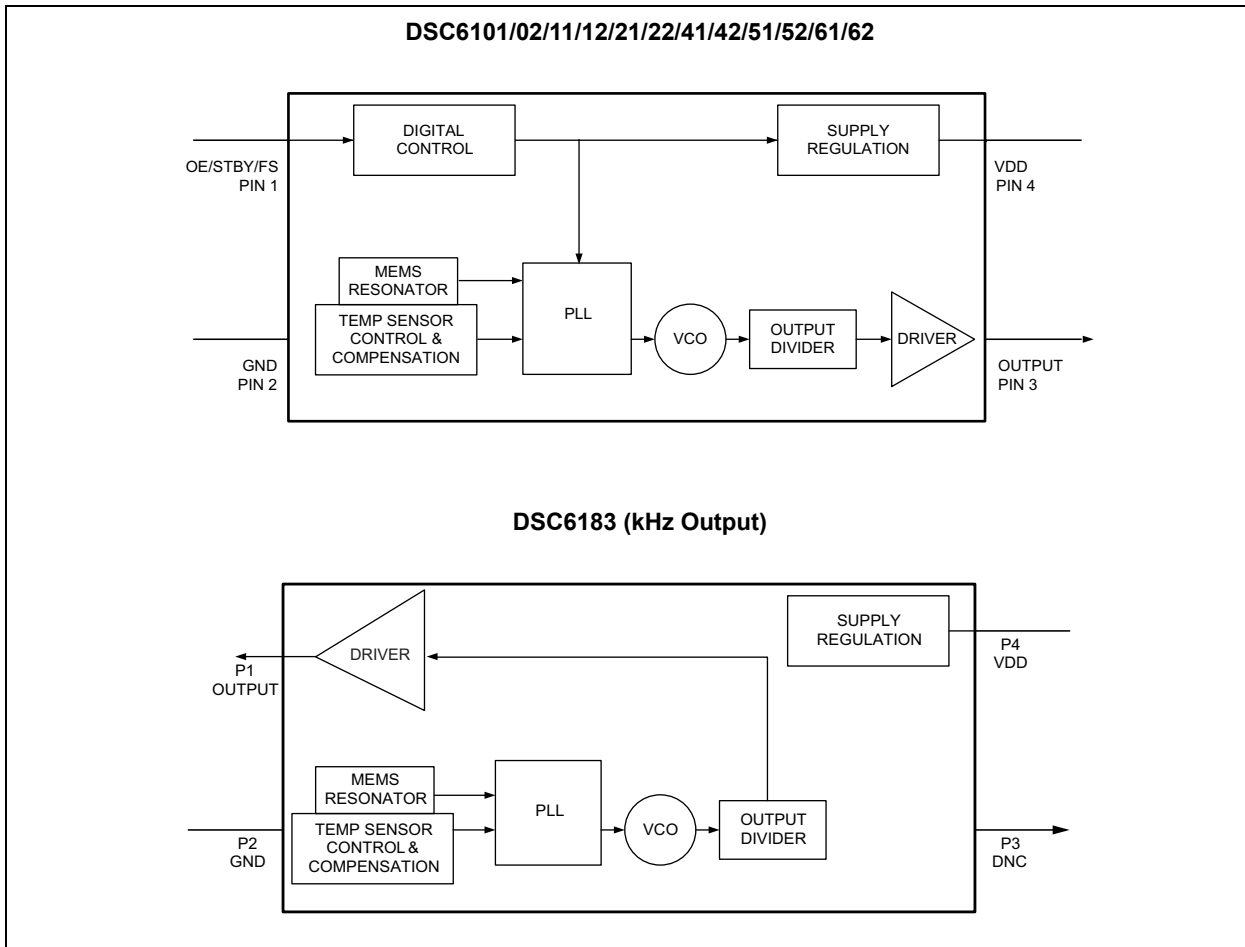

1.0 ELECTRICAL CHARACTERISTICS

Absolute Maximum Ratings

Supply Voltage	-0.3V to +4.0V
Input Voltage (V_{IN})	-0.3V to $V_{DD}+0.3V$
ESD Protection	4 kV HBM, 400V MM, 2 kV CDM

ELECTRICAL CHARACTERISTICS

Electrical Characteristics: Unless otherwise indicated, $V_{DD} = 1.8V -5\%$ to $3.3V +10\%$, $T_A = -40^{\circ}C$ to $85^{\circ}C$.							
Parameters	Sym.	Min.	Typ.	Max.	Units	Conditions	
Supply Voltage, Note 1	V_{DD}	1.71	—	3.63	V	—	
Power Supply Ramp	t_{PU}	0.1	—	100	ms	Note 8	
Active Supply Current	I_{DD}	—	3.0	—	mA	$F_{OUT} = 27$ MHz, $V_{DD} = 1.8V$, No Load	
Standby Supply Current Note 2	I_{STBY}	—	12	—	μA	$V_{DD} = 1.8/2.5V$	
		—	80	—		$V_{DD} = 3.3V$	
Frequency Stability Note 3	Δf	—	—	± 25 ± 50	ppm	All temp ranges	
Aging	Δf	—	—	± 5	ppm	1st year @ $25^{\circ}C$	
		—	—	± 1		Per year after first year	
Startup Time	t_{SU}	—	—	1.3	ms	From 90% V_{DD} to valid clock output, $T = 25^{\circ}C$	
Input Logic Levels Note 4	V_{IH}	$0.7 \times V_{DD}$	—	—	V	Input Logic High	
	V_{IL}	—	—	$0.3 \times V_{DD}$	V	Input Logic Low	
Output Disable Time Note 5	t_{DA}	—	—	200+Period	ns	—	
Output Enable Time Note 6	t_{EN}	—	—	1	μs	—	
Enable Pull-up Resistor Note 7	—	—	300	—	k Ω	If configured	
Output Logic Levels	V_{OH}	$0.8 \times V_{DD}$	—	—	V	Output Logic High, $I = 3$ mA, Std. Drive	
						Output Logic High, $I = 6$ mA, High Drive	
	V_{OL}	—	—	—	$0.2 \times V_{DD}$	V	Output Logic Low, $I = -3$ mA, Std. Drive
							Output Logic Low, $I = -3$ mA, High Drive

- Note 1:** Pin 4 V_{DD} should be filtered with 0.1 μF capacitor.
- 2:** Not including current through pull-up resistor on EN pin (if configured). Higher standby current seen at $>3.3V V_{DD}$.
- 3:** Includes frequency variations due to initial tolerance, temp. and power supply voltage.
- 4:** Input waveform must be monotonic with rise/fall time < 10 ms
- 5:** Output Disable time takes up to one period of the output waveform + 200 ns.
- 6:** For parts configured with OE, not Standby.
- 7:** Output is enabled if pad is floated or not connected.
- 8:** Time to reach 90% of target V_{DD} . Power ramp rise must be monotonic.

DSC61XX

ELECTRICAL CHARACTERISTICS (CONTINUED)

Electrical Characteristics: Unless otherwise indicated, $V_{DD} = 1.8V -5\%$ to $3.3V +10\%$, $T_A = -40^{\circ}C$ to $85^{\circ}C$.							
Parameters	Sym.	Min.	Typ.	Max.	Units	Conditions	
Output Transition Time Rise Time/Fall Time	t_{RX}/t_{FX}	—	1	1.5	ns	DSC61x2 High Drive, 20% to 80% $C_L = 15$ pF	$V_{DD} = 1.8V$
		—	0.5	1.0	ns		$V_{DD} = 2.5V/3.3V$
	t_{RY}/t_{FY}	—	1.2	2.0	ns	DSC61x1 Std Drive, 20% to 80% $C_L = 10$ pF	$V_{DD} = 1.8V$
		—	1.5	2.2	ns		$V_{DD} = 2.5V/3.3V$
Frequency	f_0	0.002	—	100	MHz	Output on Pin 1 for < 1 MHz	
Output Duty Cycle	SYM	45	—	55	%	—	
Period Jitter, RMS	J_{PER}	—	9.5	11	ps_{RMS}	$F_{OUT} = 27$ MHz	$V_{DD} = 1.8V$
		—	7.5	9			$V_{DD} = 2.5V/3.3V$
Cycle-to-Cycle Jitter (peak)	J_{CY-CY}	—	50	70	ps	$F_{OUT} = 27$ MHz	$V_{DD} = 1.8V$
		—	35	60			$V_{DD} = 2.5V/3.3V$

- Note 1:** Pin 4 V_{DD} should be filtered with 0.1 μF capacitor.
- 2:** Not including current through pull-up resistor on EN pin (if configured). Higher standby current seen at $>3.3V V_{DD}$.
- 3:** Includes frequency variations due to initial tolerance, temp. and power supply voltage.
- 4:** Input waveform must be monotonic with rise/fall time < 10 ms
- 5:** Output Disable time takes up to one period of the output waveform + 200 ns.
- 6:** For parts configured with OE, not Standby.
- 7:** Output is enabled if pad is floated or not connected.
- 8:** Time to reach 90% of target V_{DD} . Power ramp rise must be monotonic.

TEMPERATURE SPECIFICATIONS (Note 1)

Parameters	Sym.	Min.	Typ.	Max.	Units	Conditions
Temperature Ranges						
Junction Operating Temperature	T_J	—	—	+150	°C	—
Ambient Operating Temperature	T_A	-40	—	+85	°C	Industrial
Ambient Operating Temperature	T_A	-20	—	+70	°C	Extended Commercial
Storage Ambient Temperature Range	T_A	-55	—	+150	°C	—
Soldering Temperature	T_S	—	+260	—	°C	40 sec. max.

Note 1: The maximum allowable power dissipation is a function of ambient temperature, the maximum allowable junction temperature and the thermal resistance from junction to air (i.e., T_A , T_J , θ_{JA}). Exceeding the maximum allowable power dissipation will cause the device operating junction temperature to exceed the maximum +150°C rating. Sustained junction temperatures above +150°C can impact the device reliability.

DSC61XX

2.0 PIN DESCRIPTIONS

The descriptions of the pins are listed in [Table 2-1](#) and [Table 2-2](#).

TABLE 2-1: DSC6101/02/11/12/21/22/41/42/51/52/61/62 PIN FUNCTION TABLE (OUTPUT FREQUENCY ≥ 1 MHZ)

Pin Number	Pin Name	Pin Type	Description
1	OE	I	Output Enable: H = Specified Frequency Output, Note 1 L = Output is high impedance
	STBY		Standby: H = Specified Frequency Output, Note 1 L = Output is high impedance. Device is in low power mode, supply current is at I_{STBY}
	FS		Frequency Select: H = Output Frequency 1, Note 2 L = Output Frequency 2
2	GND	Power	Power supply ground
3	Output	O	Oscillator clock output
4	VDD	Power	Power supply

Note 1: DSC610x/1x/2x has 300 k Ω internal pull-up resistor on pin1. DSC614x/5x/6x has no internal pull-up resistor on pin1 and needs external pull-up or being driven by other chip.

2: Two pre-programmed frequencies can be configured at <http://clockworks.microchip.com/timing/>

3: Bypass with 0.1 μ F capacitor placed as close to V_{DD} pin as possible.

TABLE 2-2: DSC6183 PIN FUNCTION TABLE (OUTPUT FREQUENCY < 1 MHZ)

Pin Number	Pin Name	Pin Type	Description
1	Output	O	Kilohertz Oscillator clock output
2	GND	Power	Power supply ground
3	DNC	DNC	Do Not Connect
4	VDD	Power	Power supply, Note 1

Note 1: Bypass with 0.1 μ F capacitor placed as close to V_{DD} pin as possible.

2.1 Output Buffer Options

DSC61xx family is available in multiple output driver configurations.

The standard-drive (61x1) and high-drive (61x2) deliver respective output currents of greater than 3 mA and 6 mA at 20%/80% of the supply voltage. For heavy loads of 15 pF or higher, the high-drive option is recommended.

3.0 DIAGRAMS

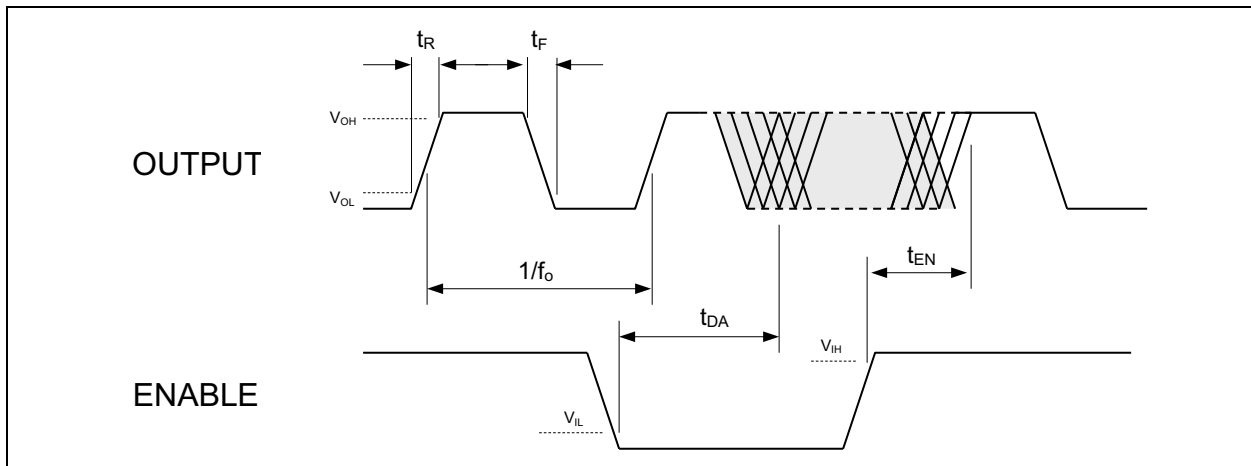

FIGURE 3-1: Output Waveform.

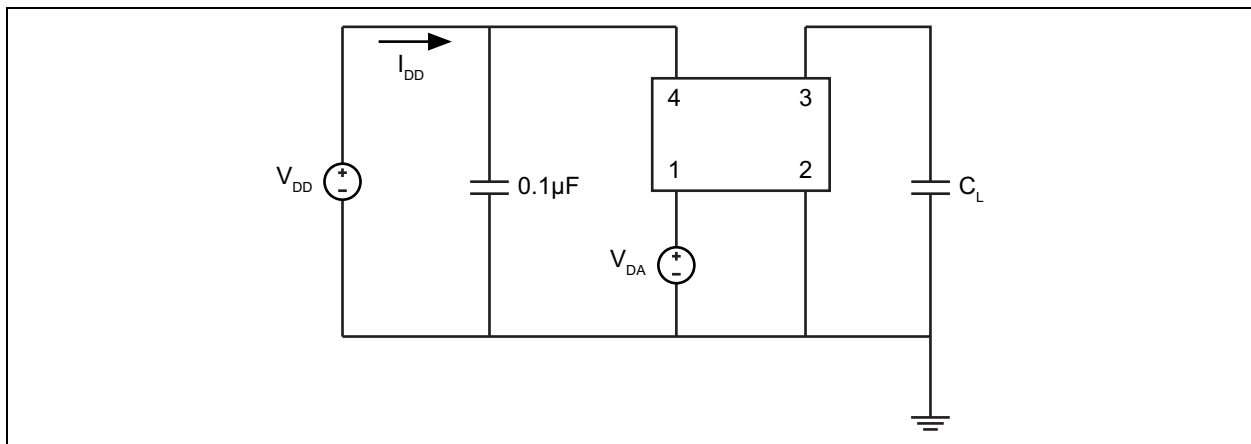

FIGURE 3-2: Test Circuit.

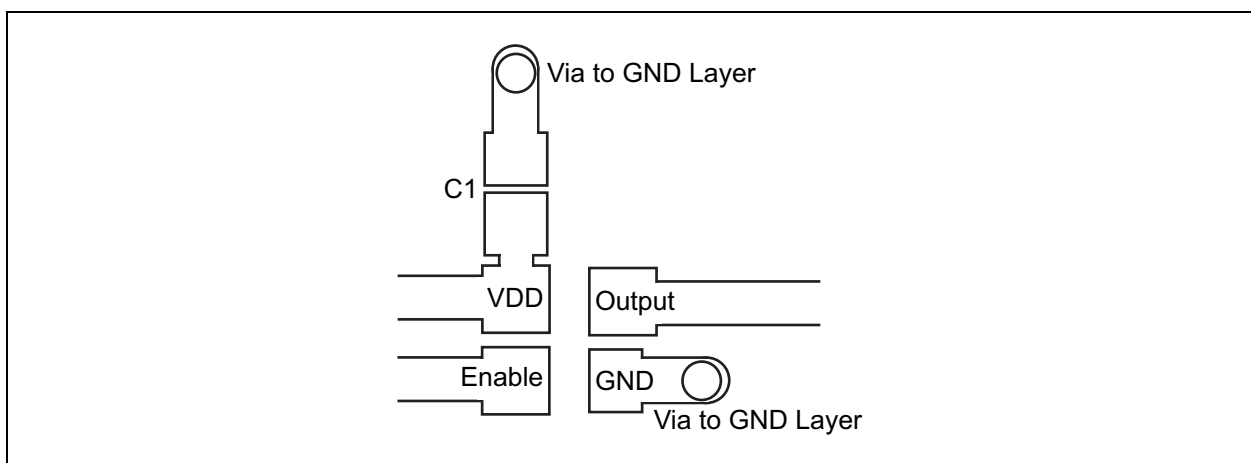

FIGURE 3-3: Recommended Board Layout.

DSC61XX

4.0 SOLDER REFLOW PROFILE

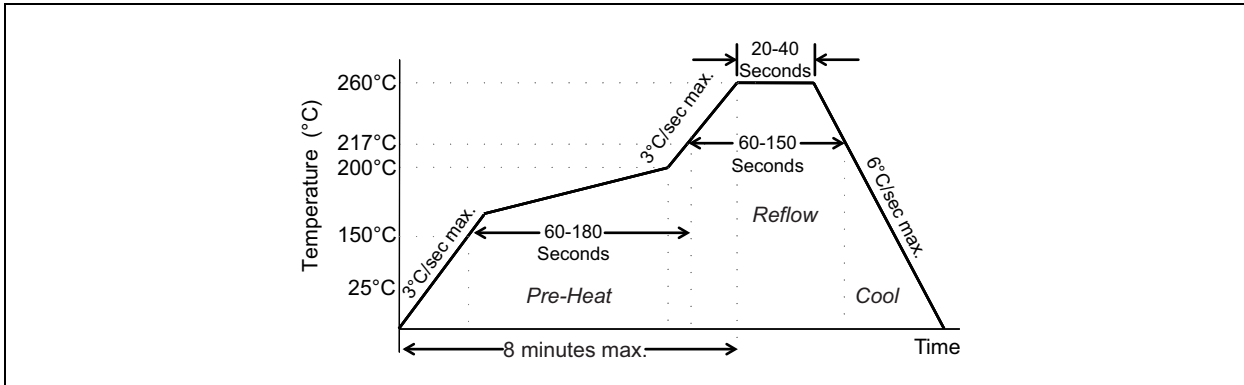

FIGURE 4-1: Solder Reflow Profile.

MSL 1 @ 260°C refer to JSTD-020C	
Ramp-Up Rate (200°C to Peak Temp)	3°C/sec. max.
Preheat Time 150°C to 200°C	60 to 180 sec.
Time maintained above 217°C	60 to 150 sec.
Peak Temperature	255°C to 260°C
Time within 5°C of actual Peak	20 to 40 sec.
Ramp-Down Rate	6°C/sec. max.
Time 25°C to Peak Temperature	8 minutes max.

5.0 PACKAGING INFORMATION

4-Lead VFLGA 1.6 mm x 1.2 mm Package Outline

4-Lead Very Thin Fine Pitch Land Grid Array (ARA) - 1.6x1.2 mm Body [VFLGA]

Note: For the most current package drawings, please see the Microchip Packaging Specification located at <http://www.microchip.com/packaging>

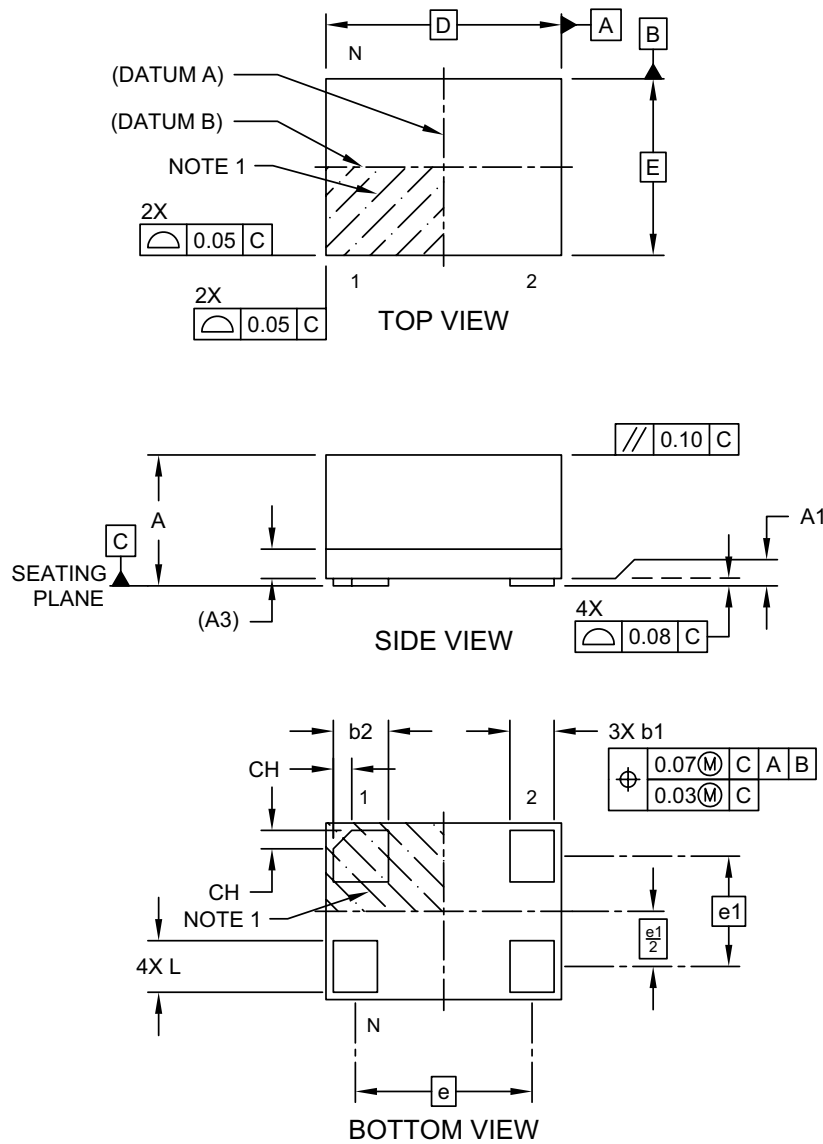

Microchip Technology Drawing C04-1199A Sheet 1 of 2

DSC61XX

4-Lead VFLGA 1.6 mm x 1.2 mm Package Outline

4-Lead Very Thin Fine Pitch Land Grid Array (ARA) - 1.6x1.2 mm Body [VFLGA]

Note: For the most current package drawings, please see the Microchip Packaging Specification located at <http://www.microchip.com/packaging>

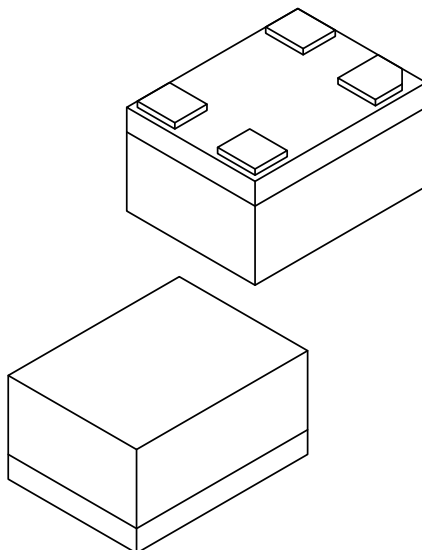

Dimension Limits	Units	MILLIMETERS		
		MIN	NOM	MAX
Number of Terminals	N	4		
Terminal Pitch	e	1.20 BSC		
Terminal Pitch	e1	0.75 BSC		
Overall Height	A	0.79	0.84	0.89
Standoff	A1	0.00	0.02	0.05
Substrate Thickness (with Terminals)	A3	0.20 REF		
Overall Length	D	1.60 BSC		
Overall Width	E	1.20 BSC		
Terminal Width	b1	0.25	0.30	0.35
Terminal Width	b2	0.325	0.375	0.425
Terminal Length	L	0.30	0.35	0.40
Terminal 1 Index Chamfer	CH	-	0.125	-

Notes:

1. Pin 1 visual index feature may vary, but must be located within the hatched area.
2. Package is saw singulated
3. Dimensioning and tolerancing per ASME Y14.5M

BSC: Basic Dimension. Theoretically exact value shown without tolerances.

REF: Reference Dimension, usually without tolerance, for information purposes only.

Microchip Technology Drawing C04-1199A Sheet 2 of 2

4-Lead VFLGA 1.6 mm x 1.2 mm Recommended Land Pattern

4-Lead Very Thin Fine Pitch Land Grid Array (ARA) - 1.6x1.2 mm Body [VFLGA]

Note: For the most current package drawings, please see the Microchip Packaging Specification located at <http://www.microchip.com/packaging>

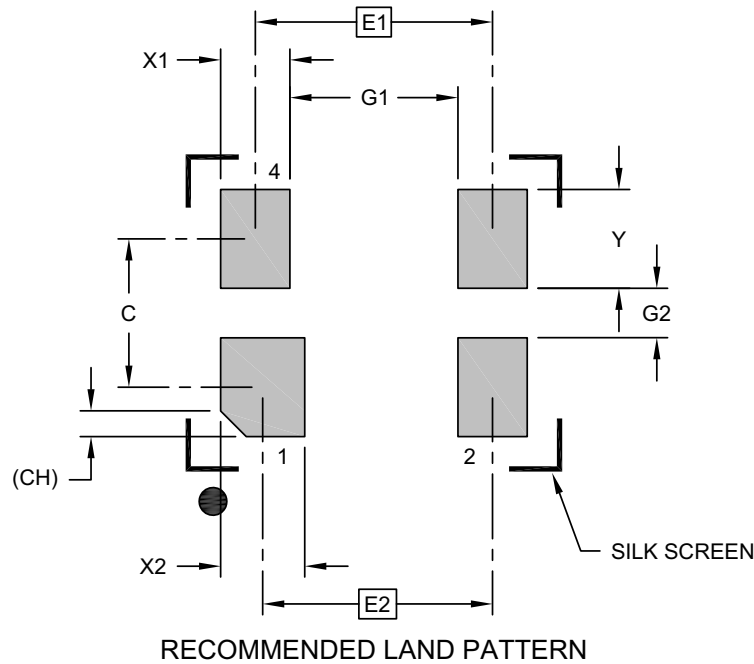

Dimension Limits	Units	MILLIMETERS		
		MIN	NOM	MAX
Contact Pitch	E1		1.20 BSC	
Contact Pitch	E2		1.16 BSC	
Contact Spacing	C		0.75	
Contact Width (X3)	X1			0.35
Contact Width	X2			0.43
Contact Pad Length (X6)	Y			0.50
Space Between Contacts (X4)	G1	0.85		
Space Between Contacts (X3)	G2	0.25		
Contact 1 Index Chamfer	CH	0.13 X 45° REF		

Notes:

1. Dimensioning and tolerancing per ASME Y14.5M
BSC: Basic Dimension. Theoretically exact value shown without tolerances.

Microchip Technology Drawing C04-3199A

DSC61XX

4-Lead VFLGA 2.0 mm x 1.6 mm Package Outline

4-Lead Very Thin Fine Pitch Land Grid Array (ASA) - 2.0x1.6 mm Body [VFLGA]

Note: For the most current package drawings, please see the Microchip Packaging Specification located at <http://www.microchip.com/packaging>

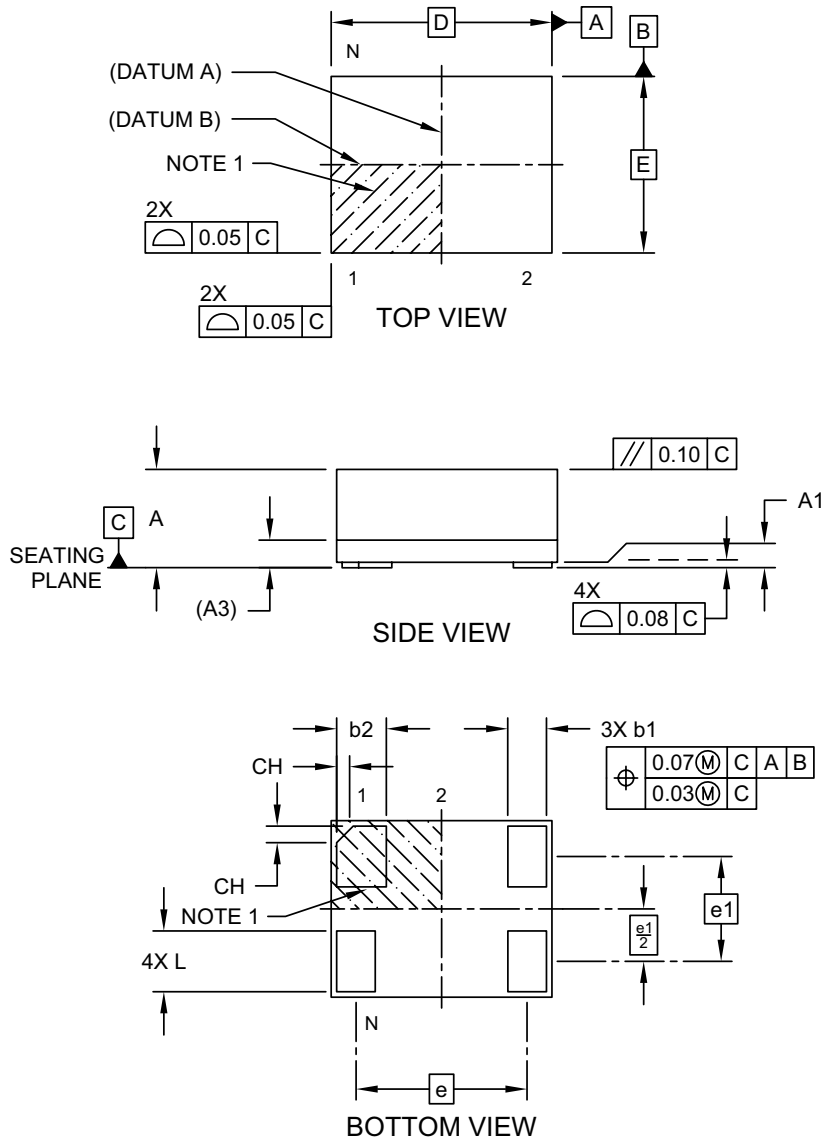

Microchip Technology Drawing C04-1200A Sheet 1 of 2

4-Lead VFLGA 2.0 mm x 1.6 mm Package Outline

4-Lead Very Thin Fine Pitch Land Grid Array (ASA) - 2.0x1.6 mm Body [VFLGA]

Note: For the most current package drawings, please see the Microchip Packaging Specification located at <http://www.microchip.com/packaging>

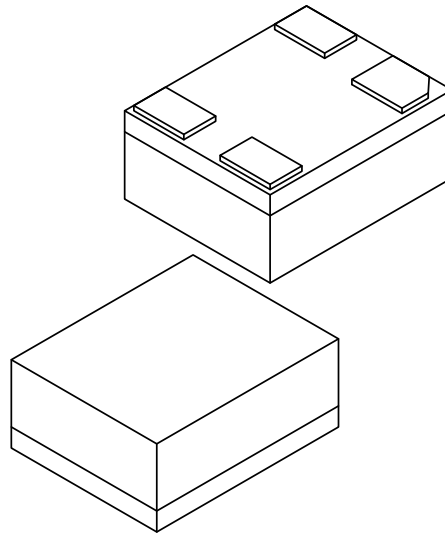

Dimension Limits	Units	MILLIMETERS		
		MIN	NOM	MAX
Number of Terminals	N	6		
Terminal Pitch	e	1.55 BSC		
Terminal Pitch	e1	0.95 BSC		
Overall Height	A	0.79	0.84	0.89
Standoff	A1	0.00	0.02	0.05
Substrate Thickness (with Terminals)	A3	0.20 REF		
Overall Length	D	2.00 BSC		
Overall Width	E	1.60 BSC		
Terminal Width	b1	0.30	0.35	0.40
Terminal Width	b2	0.40	0.45	0.50
Terminal Length	L	0.50	0.55	0.60
Terminal 1 Index Chamfer	CH	-	0.15	-

Notes:

- Pin 1 visual index feature may vary, but must be located within the hatched area.
- Package is saw singulated
- Dimensioning and tolerancing per ASME Y14.5M
 - BSC: Basic Dimension. Theoretically exact value shown without tolerances.
 - REF: Reference Dimension, usually without tolerance, for information purposes only.

Microchip Technology Drawing C04-1200A Sheet 2 of 2

DSC61XX

4-Lead VFLGA 2.0 mm x 1.6 mm Package Outline

4-Lead Very Thin Fine Pitch Land Grid Array (ASA) - 2.0x1.6 mm Body [VFLGA]

Note: For the most current package drawings, please see the Microchip Packaging Specification located at <http://www.microchip.com/packaging>

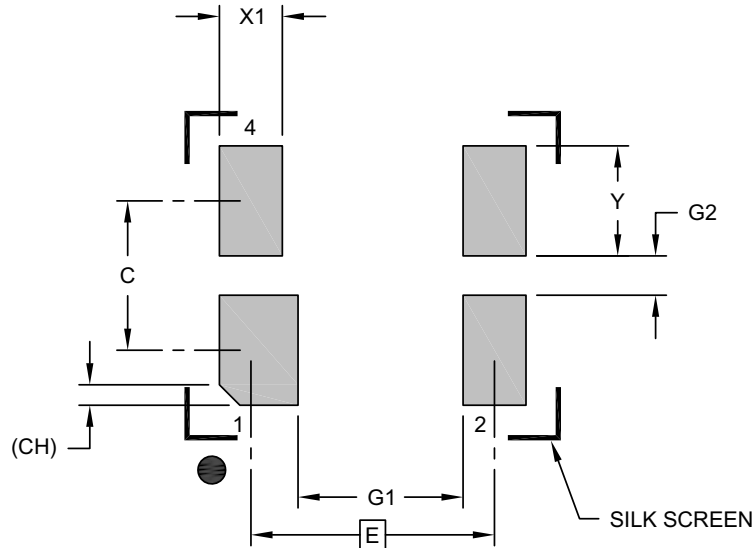

RECOMMENDED LAND PATTERN

Dimension Limits	Units	MILLIMETERS		
		MIN	NOM	MAX
Contact Pitch	E	1.55 BSC		
Contact Spacing	C		0.95	
Contact Width (X4)	X1			0.50
Contact Width (X2)	X2			0.40
Contact Pad Length (X6)	Y			0.70
Space Between Contacts (X4)	G1	1.05		
Space Between Contacts (X3)	G2	0.25		
Contact 1 Index Chamfer	CH	0.13 X 45° REF		

Notes:

1. Dimensioning and tolerancing per ASME Y14.5M
BSC: Basic Dimension. Theoretically exact value shown without tolerances.

Microchip Technology Drawing C04-3200A

4-Lead VLGA 2.5 mm x 2.0 mm Package Outline

4-Lead Very Thin Land Grid Array (AUA) - 2.5x2.0 mm Body [VLGA]

Note: For the most current package drawings, please see the Microchip Packaging Specification located at <http://www.microchip.com/packaging>

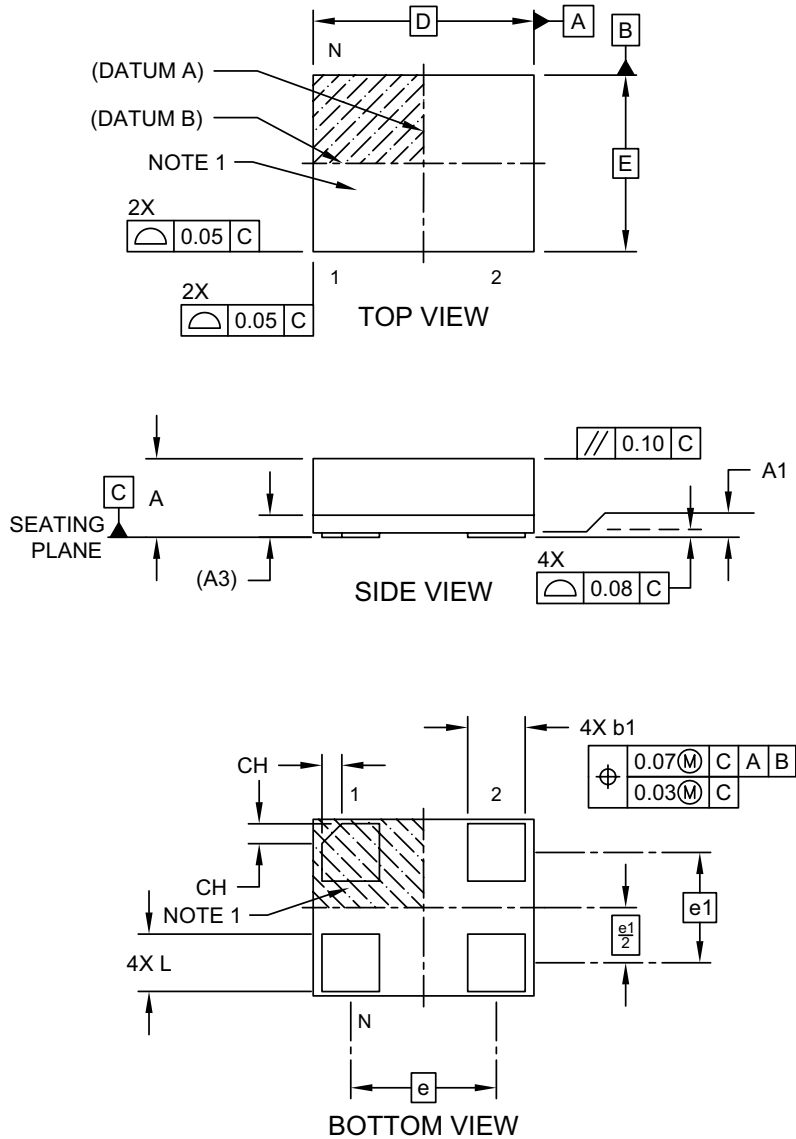

Microchip Technology Drawing C04-1202A Sheet 1 of 2

DSC61XX

4-Lead VLGA 2.5 mm x 2.0 mm Package Outline

4-Lead Very Thin Land Grid Array (AUA) - 2.5x2.0 mm Body [VLGA]

Note: For the most current package drawings, please see the Microchip Packaging Specification located at <http://www.microchip.com/packaging>

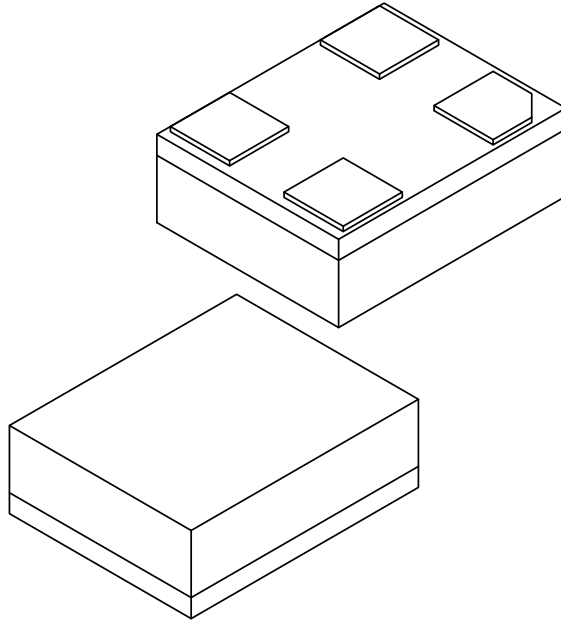

Dimension Limits	Units	MILLIMETERS		
		MIN	NOM	MAX
Number of Terminals	N	4		
Terminal Pitch	e	1.65 BSC		
Terminal Pitch	e1	1.25 BSC		
Overall Height	A	0.79	0.84	0.89
Standoff	A1	0.00	0.02	0.05
Substrate Thickness (with Terminals)	A3	0.20 REF		
Overall Length	D	2.50 BSC		
Overall Width	E	2.00 BSC		
Terminal Width	b1	0.60	0.65	0.70
Terminal Length	L	0.60	0.65	0.70
Terminal 1 Index Chamfer	CH	-	0.225	-

Notes:

1. Pin 1 visual index feature may vary, but must be located within the hatched area.
2. Package is saw singulated
3. Dimensioning and tolerancing per ASME Y14.5M
BSC: Basic Dimension. Theoretically exact value shown without tolerances.
REF: Reference Dimension, usually without tolerance, for information purposes only.

Microchip Technology Drawing C04-1202A Sheet 2 of 2

4-Lead VLGA 2.5 mm x 2.0 mm Recommended Land Pattern

4-Lead Very Thin Land Grid Array (AUA) - 2.5x2.0 mm Body [VLGA]

Note: For the most current package drawings, please see the Microchip Packaging Specification located at <http://www.microchip.com/packaging>

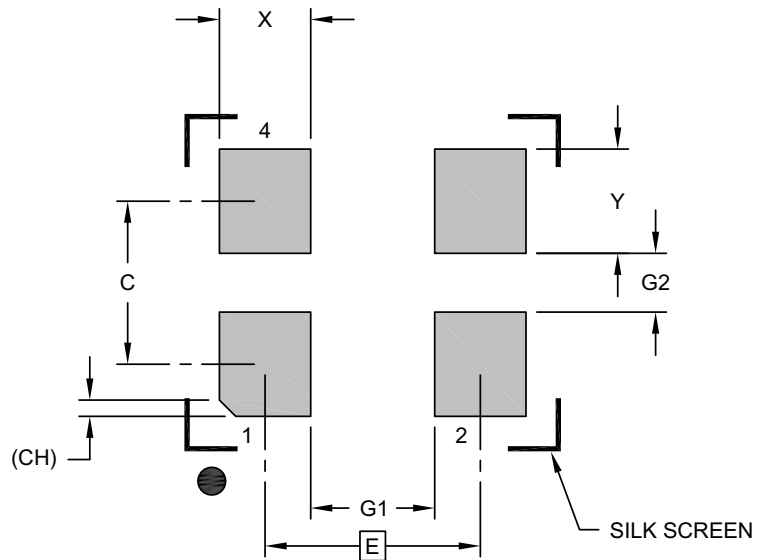

RECOMMENDED LAND PATTERN

Dimension Limits	Units	MILLIMETERS		
		MIN	NOM	MAX
Contact Pitch	E	1.65 BSC		
Contact Spacing	C		1.25	
Contact Width (X4)	X			0.70
Contact Pad Length (X6)	Y			0.80
Space Between Contacts (X4)	G1	0.95		
Space Between Contacts (X3)	G2	0.45		
Contact 1 Index Chamfer	CH	0.13 X 45° REF		

Notes:

1. Dimensioning and tolerancing per ASME Y14.5M

BSC: Basic Dimension. Theoretically exact value shown without tolerances.

Microchip Technology Drawing C04-3202A

DSC61XX

4-Lead CDFN 3.2 mm x 2.5 mm Package Outline and Recommended Land Pattern

Note: For the most current package drawings, please see the Microchip Packaging Specification located at <http://www.microchip.com/packaging>

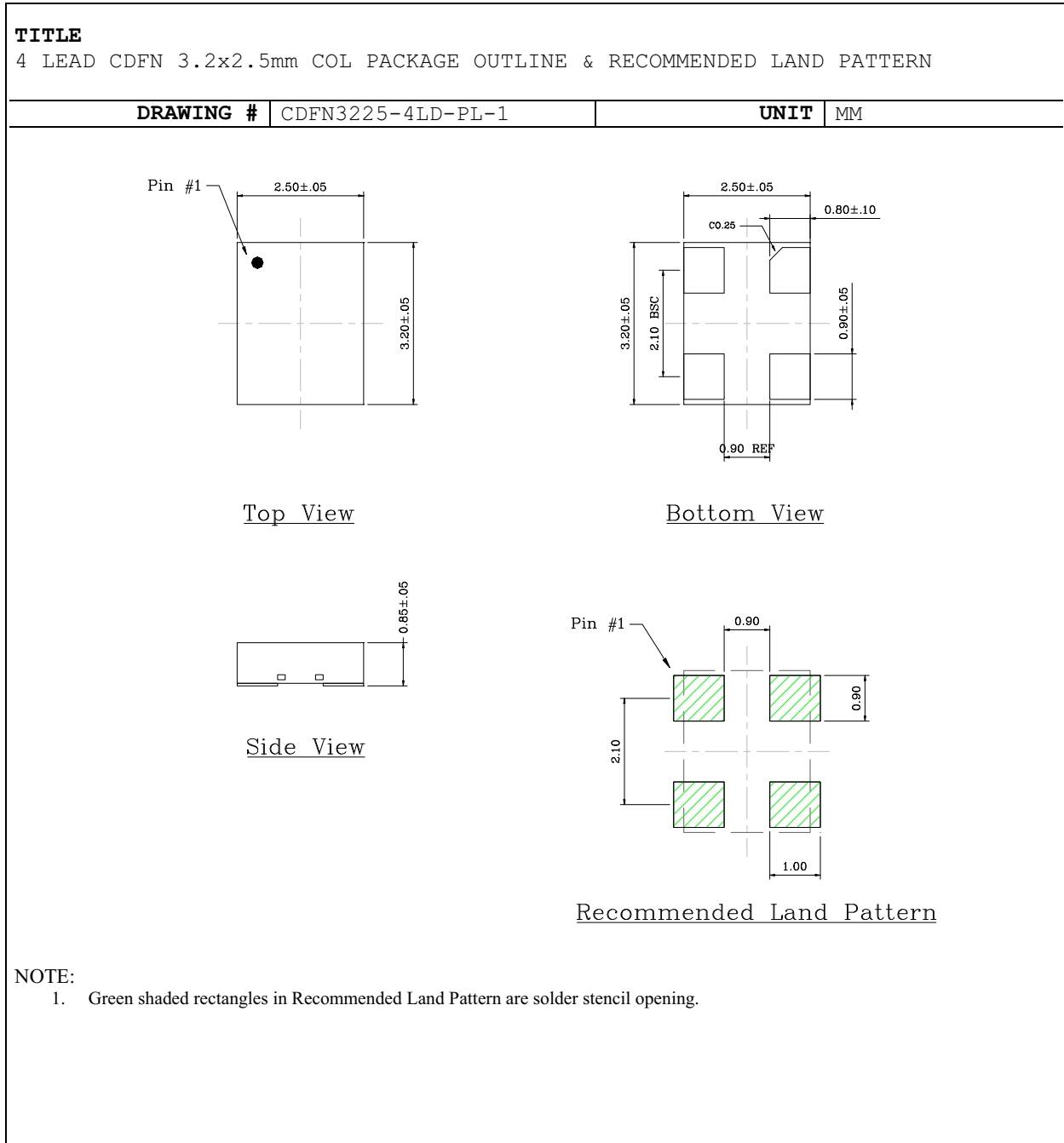

APPENDIX A: REVISION HISTORY

Revision A (September 2016)

- Initial release of DSC61xx Microchip data sheet DS20005624A.

Revision B (September 2017)

- Added Power Supply Ramp value in [Electrical Characteristics](#) table.
- Redrew diagrams for clarity. No technical content affected.

DSC61XX

NOTES:

PRODUCT IDENTIFICATION SYSTEM

To order or obtain information, e.g., on pricing or delivery, contact your local Microchip representative or sales office.

PART NO.	X	X	X	X	X	X	X - XXX.XXXX	X
Device	Pin 1 Definition	Output Drive Strength	Package	Temperature Range	Frequency Stability	Revision	Frequency	Tape and Reel
Device:	DSC61xx: Ultra-Low Power MEMS Oscillator							
Pin Definition:	Selection	Pin 1	Internal Pull-Up Register					
	0	OE	Pull-up					
	1	STBY	Pull-up					
	2	FS	Pull-up					
	4	OE	None					
	5	STBY	None					
	6	FS	None					
	8	kHz Output	None					
Output Drive Strength:	1	Standard						
	2	High						
Packages:	C	= 4-Lead 3.2 mm x 2.5 mm DFN						
	J	= 4-Lead 2.5 mm x 2.0 mm VLGA						
	M	= 4-Lead 2.0 mm x 1.6 mm VFLGA						
	H	= 4-Lead 1.6 mm x 1.2 mm VFLGA						
Temperature Range:	E	= -20°C to +70°C (Extended Commercial)						
	I	= -40°C to +85°C (Industrial)						
Frequency Stability:	1	= ± 50 ppm						
	2	= ± 25 ppm						
Revision:	A	= Revision A						
Frequency:	xxx.xxxx	= User-Defined Frequency between 001.0000 MHz and 100.0000 MHz						
	xxxkxxx	= User-Defined Frequency between 002.000 kHz and 999.999 kHz						
	xxxx	= Frequency configuration code when pin 1 = FS. Configure the part online through ClockWorks						
Tape and Reel:	<blank>	= 100/Bag						
	T	= 1,000/Reel						

Examples:

- DSC6112JI2A-100.0000:
Ultra-Low Power MEMS Oscillator, Pin1 = Standby with Internal Pull-Up, High Drive Strength, 4-Lead 2.5 mm x 2.0 mm VLGA, Industrial Temperature, ±25 ppm Stability, Revision A, 100 MHz Frequency, 100/Bag
- DSC6101HE1A-016.0000T:
Ultra-Low Power MEMS Oscillator, Pin1 = OE with Internal Pull-Up, Standard Drive Strength, 4-Lead 1.6 mm x 1.2 mm VFLGA, Extended Commercial Temp., ±50 ppm Stability, Revision A, 16 MHz Frequency, 1,000/Reel
- DSC6121MI2A-005Q:
Ultra-Low Power MEMS Oscillator, Pin1 = Freq. Select with Internal Pull-Up, Standard Drive Strength, 4-Lead 2.0 mm x 1.6 mm VFLGA, Industrial Temperature, ±25 ppm Stability, Revision A, Two Frequencies Configured through ClockWorks, 100/Bag

Note 1: Tape and Reel identifier only appears in the catalog part number description. This identifier is used for ordering purposes and is not printed on the device package. Check with your Microchip Sales Office for package availability with the Tape and Reel option.

Note 1: Please visit Microchip ClockWorks® Configurator Website to configure the part number for customized frequency. <http://clockworks.microchip.com/timing/>.

DSC61XX

NOTES:

Note the following details of the code protection feature on Microchip devices:

- Microchip products meet the specification contained in their particular Microchip Data Sheet.
- Microchip believes that its family of products is one of the most secure families of its kind on the market today, when used in the intended manner and under normal conditions.
- There are dishonest and possibly illegal methods used to breach the code protection feature. All of these methods, to our knowledge, require using the Microchip products in a manner outside the operating specifications contained in Microchip's Data Sheets. Most likely, the person doing so is engaged in theft of intellectual property.
- Microchip is willing to work with the customer who is concerned about the integrity of their code.
- Neither Microchip nor any other semiconductor manufacturer can guarantee the security of their code. Code protection does not mean that we are guaranteeing the product as “unbreakable.”

Code protection is constantly evolving. We at Microchip are committed to continuously improving the code protection features of our products. Attempts to break Microchip's code protection feature may be a violation of the Digital Millennium Copyright Act. If such acts allow unauthorized access to your software or other copyrighted work, you may have a right to sue for relief under that Act.

Information contained in this publication regarding device applications and the like is provided only for your convenience and may be superseded by updates. It is your responsibility to ensure that your application meets with your specifications. MICROCHIP MAKES NO REPRESENTATIONS OR WARRANTIES OF ANY KIND WHETHER EXPRESS OR IMPLIED, WRITTEN OR ORAL, STATUTORY OR OTHERWISE, RELATED TO THE INFORMATION, INCLUDING BUT NOT LIMITED TO ITS CONDITION, QUALITY, PERFORMANCE, MERCHANTABILITY OR FITNESS FOR PURPOSE. Microchip disclaims all liability arising from this information and its use. Use of Microchip devices in life support and/or safety applications is entirely at the buyer's risk, and the buyer agrees to defend, indemnify and hold harmless Microchip from any and all damages, claims, suits, or expenses resulting from such use. No licenses are conveyed, implicitly or otherwise, under any Microchip intellectual property rights unless otherwise stated.

Microchip received ISO/TS-16949:2009 certification for its worldwide headquarters, design and wafer fabrication facilities in Chandler and Tempe, Arizona; Gresham, Oregon and design centers in California and India. The Company's quality system processes and procedures are for its PIC® MCUs and dsPIC® DSCs, KEELoQ® code hopping devices, Serial EEPROMs, microperipherals, nonvolatile memory and analog products. In addition, Microchip's quality system for the design and manufacture of development systems is ISO 9001:2000 certified.

**QUALITY MANAGEMENT SYSTEM
CERTIFIED BY DNV
= ISO/TS 16949 =**

Trademarks

The Microchip name and logo, the Microchip logo, AnyRate, AVR, AVR logo, AVR Freaks, BeaconThings, BitCloud, CryptoMemory, CryptoRF, dsPIC, FlashFlex, flexPWR, Heldo, JukeBlox, KEELoQ, KEELoQ logo, Kleer, LANCheck, LINK MD, maXStylus, maXTouch, MediaLB, megaAVR, MOST, MOST logo, MPLAB, OptoLyzer, PIC, picoPower, PICSTART, PIC32 logo, Prochip Designer, QTouch, RightTouch, SAM-BA, SpyNIC, SST, SST Logo, SuperFlash, tinyAVR, UNI/O, and XMEGA are registered trademarks of Microchip Technology Incorporated in the U.S.A. and other countries.

ClockWorks, The Embedded Control Solutions Company, EtherSynch, Hyper Speed Control, HyperLight Load, IntelliMOS, mTouch, Precision Edge, and Quiet-Wire are registered trademarks of Microchip Technology Incorporated in the U.S.A.

Adjacent Key Suppression, AKS, Analog-for-the-Digital Age, Any Capacitor, AnyIn, AnyOut, BodyCom, chipKIT, chipKIT logo, CodeGuard, CryptoAuthentication, CryptoCompanion, CryptoController, dsPICDEM, dsPICDEM.net, Dynamic Average Matching, DAM, ECAN, EtherGREEN, In-Circuit Serial Programming, ICSP, Inter-Chip Connectivity, JitterBlocker, KleerNet, KleerNet logo, Mindi, MiWi, motorBench, MPASM, MPF, MPLAB Certified logo, MPLIB, MPLINK, MultiTRAK, NetDetach, Omniscient Code Generation, PICDEM, PICDEM.net, PICKit, PICtail, PureSilicon, QMatrix, RightTouch logo, REAL ICE, Ripple Blocker, SAM-ICE, Serial Quad I/O, SMART-I.S., SQI, SuperSwitcher, SuperSwitcher II, Total Endurance, TSHARC, USBCheck, VariSense, ViewSpan, WiperLock, Wireless DNA, and ZENA are trademarks of Microchip Technology Incorporated in the U.S.A. and other countries.

SQTP is a service mark of Microchip Technology Incorporated in the U.S.A.

Silicon Storage Technology is a registered trademark of Microchip Technology Inc. in other countries.

GestIC is a registered trademark of Microchip Technology Germany II GmbH & Co. KG, a subsidiary of Microchip Technology Inc., in other countries.

All other trademarks mentioned herein are property of their respective companies.

© 2017, Microchip Technology Incorporated, All Rights Reserved.
ISBN: 978-1-5224-0961-8



MICROCHIP

Worldwide Sales and Service

AMERICAS

Corporate Office
2355 West Chandler Blvd.
Chandler, AZ 85224-6199
Tel: 480-792-7200
Fax: 480-792-7277
Technical Support:
<http://www.microchip.com/support>
Web Address:
www.microchip.com

Atlanta
Duluth, GA
Tel: 678-957-9614
Fax: 678-957-1455

Austin, TX
Tel: 512-257-3370

Boston
Westborough, MA
Tel: 774-760-0087
Fax: 774-760-0088

Chicago
Itasca, IL
Tel: 630-285-0071
Fax: 630-285-0075

Dallas
Addison, TX
Tel: 972-818-7423
Fax: 972-818-2924

Detroit
Novi, MI
Tel: 248-848-4000

Houston, TX
Tel: 281-894-5983

Indianapolis
Noblesville, IN
Tel: 317-773-8323
Fax: 317-773-5453
Tel: 317-536-2380

Los Angeles
Mission Viejo, CA
Tel: 949-462-9523
Fax: 949-462-9608
Tel: 951-273-7800

Raleigh, NC
Tel: 919-844-7510

New York, NY
Tel: 631-435-6000

San Jose, CA
Tel: 408-735-9110
Tel: 408-436-4270

Canada - Toronto
Tel: 905-695-1980
Fax: 905-695-2078

ASIA/PACIFIC

Asia Pacific Office
Suites 3707-14, 37th Floor
Tower 6, The Gateway
Harbour City, Kowloon

Hong Kong
Tel: 852-2943-5100
Fax: 852-2401-3431

Australia - Sydney
Tel: 61-2-9868-6733
Fax: 61-2-9868-6755

China - Beijing
Tel: 86-10-8569-7000
Fax: 86-10-8528-2104

China - Chengdu
Tel: 86-28-8665-5511
Fax: 86-28-8665-7889

China - Chongqing
Tel: 86-23-8980-9588
Fax: 86-23-8980-9500

China - Dongguan
Tel: 86-769-8702-9880

China - Guangzhou
Tel: 86-20-8755-8029

China - Hangzhou
Tel: 86-571-8792-8115
Fax: 86-571-8792-8116

China - Hong Kong SAR
Tel: 852-2943-5100
Fax: 852-2401-3431

China - Nanjing
Tel: 86-25-8473-2460
Fax: 86-25-8473-2470

China - Qingdao
Tel: 86-532-8502-7355
Fax: 86-532-8502-7205

China - Shanghai
Tel: 86-21-3326-8000
Fax: 86-21-3326-8021

China - Shenyang
Tel: 86-24-2334-2829
Fax: 86-24-2334-2393

China - Shenzhen
Tel: 86-755-8864-2200
Fax: 86-755-8203-1760

China - Wuhan
Tel: 86-27-5980-5300
Fax: 86-27-5980-5118

China - Xian
Tel: 86-29-8833-7252
Fax: 86-29-8833-7256

ASIA/PACIFIC

China - Xiamen
Tel: 86-592-2388138
Fax: 86-592-2388130

China - Zhuhai
Tel: 86-756-3210040
Fax: 86-756-3210049

India - Bangalore
Tel: 91-80-3090-4444
Fax: 91-80-3090-4123

India - New Delhi
Tel: 91-11-4160-8631
Fax: 91-11-4160-8632

India - Pune
Tel: 91-20-3019-1500

Japan - Osaka
Tel: 81-6-6152-7160
Fax: 81-6-6152-9310

Japan - Tokyo
Tel: 81-3-6880-3770
Fax: 81-3-6880-3771

Korea - Daegu
Tel: 82-53-744-4301
Fax: 82-53-744-4302

Korea - Seoul
Tel: 82-2-554-7200
Fax: 82-2-558-5932 or
82-2-558-5934

Malaysia - Kuala Lumpur
Tel: 60-3-6201-9857
Fax: 60-3-6201-9859

Malaysia - Penang
Tel: 60-4-227-8870
Fax: 60-4-227-4068

Philippines - Manila
Tel: 63-2-634-9065
Fax: 63-2-634-9069

Singapore
Tel: 65-6334-8870
Fax: 65-6334-8850

Taiwan - Hsin Chu
Tel: 886-3-5778-366
Fax: 886-3-5770-955

Taiwan - Kaohsiung
Tel: 886-7-213-7830

Taiwan - Taipei
Tel: 886-2-2508-8600
Fax: 886-2-2508-0102

Thailand - Bangkok
Tel: 66-2-694-1351
Fax: 66-2-694-1350

EUROPE

Austria - Wels
Tel: 43-7242-2244-39
Fax: 43-7242-2244-393

Denmark - Copenhagen
Tel: 45-4450-2828
Fax: 45-4485-2829

Finland - Espoo
Tel: 358-9-4520-820

France - Paris
Tel: 33-1-69-53-63-20
Fax: 33-1-69-30-90-79

France - Saint Cloud
Tel: 33-1-30-60-70-00

Germany - Garching
Tel: 49-8931-9700

Germany - Haan
Tel: 49-2129-3766400

Germany - Heilbronn
Tel: 49-7131-67-3636

Germany - Karlsruhe
Tel: 49-721-625370

Germany - Munich
Tel: 49-89-627-144-0
Fax: 49-89-627-144-44

Germany - Rosenheim
Tel: 49-8031-354-560

Israel - Ra'anana
Tel: 972-9-744-7705

Italy - Milan
Tel: 39-0331-742611
Fax: 39-0331-466781

Italy - Padova
Tel: 39-049-7625286

Netherlands - Drunen
Tel: 31-416-690399
Fax: 31-416-690340

Norway - Trondheim
Tel: 47-7289-7561

Poland - Warsaw
Tel: 48-22-3325737

Romania - Bucharest
Tel: 40-21-407-87-50

Spain - Madrid
Tel: 34-91-708-08-90
Fax: 34-91-708-08-91

Sweden - Gothenberg
Tel: 46-31-704-60-40

Sweden - Stockholm
Tel: 46-8-5090-4654

UK - Wokingham
Tel: 44-118-921-5800
Fax: 44-118-921-5820