

2 Mbit / 4 Mbit / 8 Mbit (x16) Multi-Purpose Flash

SST39LF200A / SST39LF400A / SST39LF800A

SST39VF200A / SST39VF400A / SST39VF800A



Data Sheet

FEATURES:

- **Organized as 128K x16 / 256K x16 / 512K x16**
- **Single Voltage Read and Write Operations**
 - 3.0-3.6V for SST39LF200A/400A/800A
 - 2.7-3.6V for SST39VF200A/400A/800A
- **Superior Reliability**
 - Endurance: 100,000 Cycles (typical)
 - Greater than 100 years Data Retention
- **Low Power Consumption (typical values at 14 MHz)**
 - Active Current: 9 mA (typical)
 - Standby Current: 3 μ A (typical)
- **Sector-Erase Capability**
 - Uniform 2 KWord sectors
- **Block-Erase Capability**
 - Uniform 32 KWord blocks
- **Fast Read Access Time**
 - 55 ns for SST39LF200A/400A/800A
 - 70 ns for SST39VF200A/400A/800A
- **Latched Address and Data**
- **Fast Erase and Word-Program**
 - Sector-Erase Time: 18 ms (typical)
 - Block-Erase Time: 18 ms (typical)
 - Chip-Erase Time: 70 ms (typical)
 - Word-Program Time: 14 μ s (typical)
 - Chip Rewrite Time:
 - 2 seconds (typical) for SST39LF/VF200A
 - 4 seconds (typical) for SST39LF/VF400A
 - 8 seconds (typical) for SST39LF/VF800A
- **Automatic Write Timing**
 - Internal V_{PP} Generation
- **End-of-Write Detection**
 - Toggle Bit
 - Data# Polling
- **CMOS I/O Compatibility**
- **JEDEC Standard**
 - Flash EEPROM Pinouts and command sets
- **Packages Available**
 - 48-lead TSOP (12mm x 20mm)
 - 48-ball TFBGA (6mm x 8mm)
 - 48-ball WFBGA (4mm x 6mm)
 - 48-bump XFLGA (4mm x 6mm) – 4 and 8Mbit
- **All non-Pb (lead-free) devices are RoHS compliant**

PRODUCT DESCRIPTION

The SST39LF200A/400A/800A and SST39VF200A/400A/800A devices are 128K x16 / 256K x16 / 512K x16 CMOS Multi-Purpose Flash (MPF) manufactured with SST proprietary, high-performance CMOS SuperFlash technology. The split-gate cell design and thick oxide tunneling injector attain better reliability and manufacturability compared with alternate approaches. The SST39LF200A/400A/800A write (Program or Erase) with a 3.0-3.6V power supply. The SST39VF200A/400A/800A write (Program or Erase) with a 2.7-3.6V power supply. These devices conform to JEDEC standard pinouts for x16 memories.

Featuring high-performance Word-Program, the SST39LF200A/400A/800A and SST39VF200A/400A/800A devices provide a typical Word-Program time of 14 μ sec. The devices use Toggle Bit or Data# Polling to detect the completion of the Program or Erase operation. To protect against inadvertent write, they have on-chip hardware and software data protection schemes. Designed, manufactured, and tested for a wide spectrum of applications, these devices are offered with a guaranteed typical endurance of 100,000 cycles. Data retention is rated at greater than 100 years.

The SST39LF200A/400A/800A and SST39VF200A/400A/800A devices are suited for applications that require convenient and economical updating of program, configuration, or data memory. For all system applications, they significantly improve performance and reliability, while lowering power consumption. They inherently use less energy during Erase and Program than alternative flash technologies. When programming a flash device, the total energy consumed is a function of the applied voltage, current, and time of application. Since for any given voltage range, the SuperFlash technology uses less current to program and has a shorter erase time, the total energy consumed during any Erase or Program operation is less than alternative flash technologies. These devices also improve flexibility while lowering the cost for program, data, and configuration storage applications.

The SuperFlash technology provides fixed Erase and Program times, independent of the number of Erase/Program cycles that have occurred. Therefore the system software or hardware does not have to be modified or de-rated as is necessary with alternative flash technologies, whose Erase and Program times increase with accumulated Erase/Program cycles.



2 Mbit / 4 Mbit / 8 Mbit Multi-Purpose Flash SST39LF200A / SST39LF400A / SST39LF800A SST39VF200A / SST39VF400A / SST39VF800A

Data Sheet

To meet surface mount requirements, the SST39LF200A/400A/800A and SST39VF200A/400A/800A are offered in 48-lead TSOP packages and 48-ball TFBGA packages as well as Micro-Packages. See Figures 2, 3, and 4 for pin assignments.

Device Operation

Commands are used to initiate the memory operation functions of the device. Commands are written to the device using standard microprocessor write sequences. A command is written by asserting WE# low while keeping CE# low. The address bus is latched on the falling edge of WE# or CE#, whichever occurs last. The data bus is latched on the rising edge of WE# or CE#, whichever occurs first.

Read

The Read operation of the SST39LF200A/400A/800A and SST39VF200A/400A/800A is controlled by CE# and OE#, both have to be low for the system to obtain data from the outputs. CE# is used for device selection. When CE# is high, the chip is deselected and only standby power is consumed. OE# is the output control and is used to gate data from the output pins. The data bus is in high impedance state when either CE# or OE# is high. Refer to the Read cycle timing diagram for further details (Figure 5).

Word-Program Operation

The SST39LF200A/400A/800A and SST39VF200A/400A/800A are programmed on a word-by-word basis. Before programming, the sector where the word exists must be fully erased. The Program operation is accomplished in three steps. The first step is the three-byte load sequence for Software Data Protection. The second step is to load word address and word data. During the Word-Program operation, the addresses are latched on the falling edge of either CE# or WE#, whichever occurs last. The data is latched on the rising edge of either CE# or WE#, whichever occurs first. The third step is the internal Program operation which is initiated after the rising edge of the fourth WE# or CE#, whichever occurs first. The Program operation, once initiated, will be completed within 20 μ s. See Figures 6 and 7 for WE# and CE# controlled Program operation timing diagrams and Figure 18 for flowcharts. During the Program operation, the only valid reads are Data# Polling and Toggle Bit. During the internal Program operation, the host is free to perform additional tasks. Any commands issued during the internal Program operation are ignored.

Sector/Block-Erase Operation

The Sector- (or Block-) Erase operation allows the system to erase the device on a sector-by-sector (or block-by-block) basis. The SST39LF200A/400A/800A and SST39VF200A/400A/800A offers both Sector-Erase and Block-Erase mode. The sector architecture is based on uniform sector size of 2 KWord. The Block-Erase mode is based on uniform block size of 32 KWord. The Sector-Erase operation is initiated by executing a six-byte command sequence with Sector-Erase command (30H) and sector address (SA) in the last bus cycle. The Block-Erase operation is initiated by executing a six-byte command sequence with Block-Erase command (50H) and block address (BA) in the last bus cycle. The sector or block address is latched on the falling edge of the sixth WE# pulse, while the command (30H or 50H) is latched on the rising edge of the sixth WE# pulse. The internal Erase operation begins after the sixth WE# pulse. The End-of-Erase operation can be determined using either Data# Polling or Toggle Bit methods. See Figures 11 and 12 for timing waveforms. Any commands issued during the Sector- or Block-Erase operation are ignored.

Chip-Erase Operation

The SST39LF200A/400A/800A and SST39VF200A/400A/800A provide a Chip-Erase operation, which allows the user to erase the entire memory array to the "1" state. This is useful when the entire device must be quickly erased.

The Chip-Erase operation is initiated by executing a six-byte command sequence with Chip-Erase command (10H) at address 5555H in the last byte sequence. The Erase operation begins with the rising edge of the sixth WE# or CE#, whichever occurs first. During the Erase operation, the only valid read is Toggle Bit or Data# Polling. See Table 4 for the command sequence, Figure 10 for timing diagram, and Figure 21 for the flowchart. Any commands issued during the Chip-Erase operation are ignored.

Write Operation Status Detection

The SST39LF200A/400A/800A and SST39VF200A/400A/800A provide two software means to detect the completion of a write (Program or Erase) cycle, in order to optimize the system write cycle time. The software detection includes two status bits: Data# Polling (DQ₇) and Toggle Bit (DQ₆). The End-of-Write detection mode is enabled after the rising edge of WE#, which initiates the internal Program or Erase operation.



The actual completion of the nonvolatile write is asynchronous with the system; therefore, either a Data# Polling or Toggle Bit read may be simultaneous with the completion of the write cycle. If this occurs, the system may possibly get an erroneous result, i.e., valid data may appear to conflict with either DQ₇ or DQ₆. In order to prevent spurious rejection, if an erroneous result occurs, the software routine should include a loop to read the accessed location an additional two (2) times. If both reads are valid, then the device has completed the write cycle, otherwise the rejection is valid.

Data# Polling (DQ₇)

When the SST39LF200A/400A/800A and SST39VF200A/400A/800A are in the internal Program operation, any attempt to read DQ₇ will produce the complement of the true data. Once the Program operation is completed, DQ₇ will produce true data. Note that even though DQ₇ may have valid data immediately following the completion of an internal Write operation, the remaining data outputs may still be invalid: valid data on the entire data bus will appear in subsequent successive Read cycles after an interval of 1 μ s. During internal Erase operation, any attempt to read DQ₇ will produce a '0'. Once the internal Erase operation is completed, DQ₇ will produce a '1'. The Data# Polling is valid after the rising edge of fourth WE# (or CE#) pulse for Program operation. For Sector-, Block- or Chip-Erase, the Data# Polling is valid after the rising edge of sixth WE# (or CE#) pulse. See Figure 8 for Data# Polling timing diagram and Figure 19 for a flowchart.

Toggle Bit (DQ₆)

During the internal Program or Erase operation, any consecutive attempts to read DQ₆ will produce alternating 1s and 0s, i.e., toggling between 1 and 0. When the internal Program or Erase operation is completed, the DQ₆ bit will stop toggling. The device is then ready for the next operation. The Toggle Bit is valid after the rising edge of fourth WE# (or CE#) pulse for Program operation. For Sector-, Block- or Chip-Erase, the Toggle Bit is valid after the rising edge of sixth WE# (or CE#) pulse. See Figure 9 for Toggle Bit timing diagram and Figure 19 for a flowchart.

Data Protection

The SST39LF200A/400A/800A and SST39VF200A/400A/800A provide both hardware and software features to protect nonvolatile data from inadvertent writes.

Hardware Data Protection

Noise/Glitch Protection: A WE# or CE# pulse of less than 5 ns will not initiate a write cycle.

V_{DD} Power Up/Down Detection: The Write operation is inhibited when V_{DD} is less than 1.5V.

Write Inhibit Mode: Forcing OE# low, CE# high, or WE# high will inhibit the Write operation. This prevents inadvertent writes during power-up or power-down.

Software Data Protection (SDP)

The SST39LF200A/400A/800A and SST39VF200A/400A/800A provide the JEDEC approved Software Data Protection scheme for all data alteration operations, i.e., Program and Erase. Any Program operation requires the inclusion of the three-byte sequence. The three-byte load sequence is used to initiate the Program operation, providing optimal protection from inadvertent Write operations, e.g., during the system power-up or power-down. Any Erase operation requires the inclusion of six-byte sequence. This group of devices are shipped with the Software Data Protection permanently enabled. See Table 4 for the specific software command codes. During SDP command sequence, invalid commands will abort the device to Read mode within TRC. The contents of DQ₁₅-DQ₈ can be V_{IL} or V_{IH}, but no other value, during any SDP command sequence.

Common Flash Memory Interface (CFI)

The SST39LF200A/400A/800A and SST39VF200A/400A/800A also contain the CFI information to describe the characteristics of the device. In order to enter the CFI Query mode, the system must write three-byte sequence, same as Software ID Entry command with 98H (CFI Query command) to address 5555H in the last byte sequence. Once the device enters the CFI Query mode, the system can read CFI data at the addresses given in Tables 5 through 9. The system must write the CFI Exit command to return to Read mode from the CFI Query mode.



2 Mbit / 4 Mbit / 8 Mbit Multi-Purpose Flash SST39LF200A / SST39LF400A / SST39LF800A SST39VF200A / SST39VF400A / SST39VF800A

Data Sheet

Product Identification

The Product Identification mode identifies the devices as the SST39LF/VF200A, SST39LF/VF400A and SST39LF/VF800A and manufacturer as SST. This mode may be accessed by software operations. Users may use the Software Product Identification operation to identify the part (i.e., using the device ID) when using multiple manufacturers in the same socket. For details, see Table 4 for software operation, Figure 13 for the Software ID Entry and Read timing diagram, and Figure 20 for the Software ID Entry command sequence flowchart.

TABLE 1: Product Identification

	Address	Data
Manufacturer's ID	0000H	00BFH
Device ID		
SST39LF/VF200A	0001H	2789H
SST39LF/VF400A	0001H	2780H
SST39LF/VF800A	0001H	2781H

T1.3 1117

Product Identification Mode Exit/ CFI Mode Exit

In order to return to the standard Read mode, the Software Product Identification mode must be exited. Exit is accomplished by issuing the Software ID Exit command sequence, which returns the device to the Read mode. This command may also be used to reset the device to the Read mode after any inadvertent transient condition that apparently causes the device to behave abnormally, e.g., not read correctly. Please note that the Software ID Exit/CFI Exit command is ignored during an internal Program or Erase operation. See Table 4 for software command codes, Figure 15 for timing waveform, and Figure 20 for a flowchart.

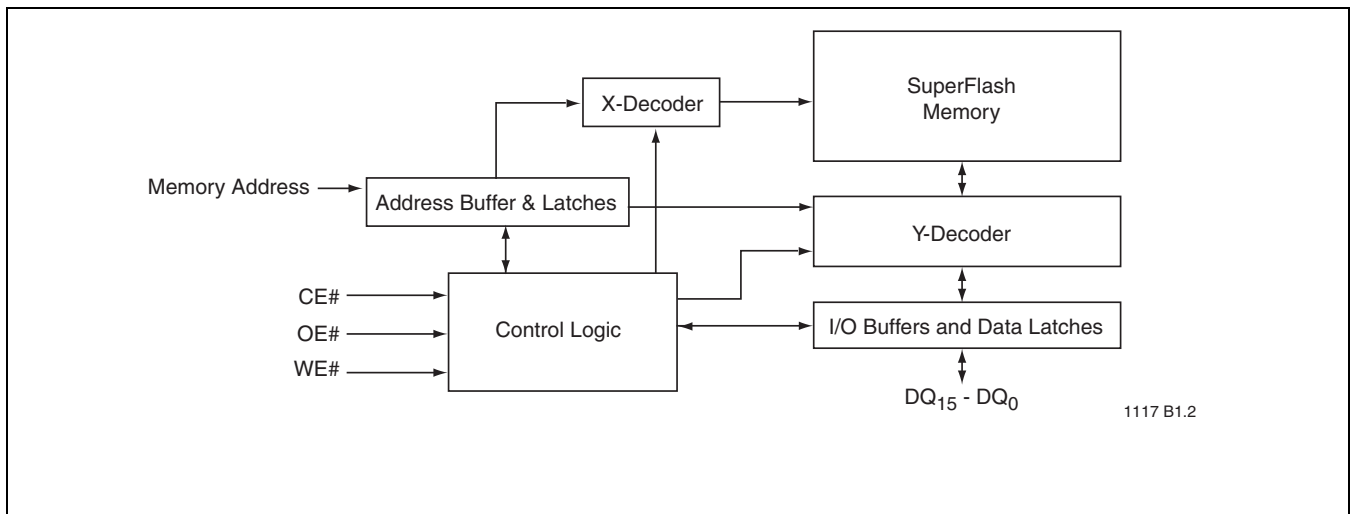

1117 B1.2

FIGURE 1: Functional Block Diagram

2 Mbit / 4 Mbit / 8 Mbit Multi-Purpose Flash
SST39LF200A / SST39LF400A / SST39LF800A
SST39VF200A / SST39VF400A / SST39VF800A



Data Sheet

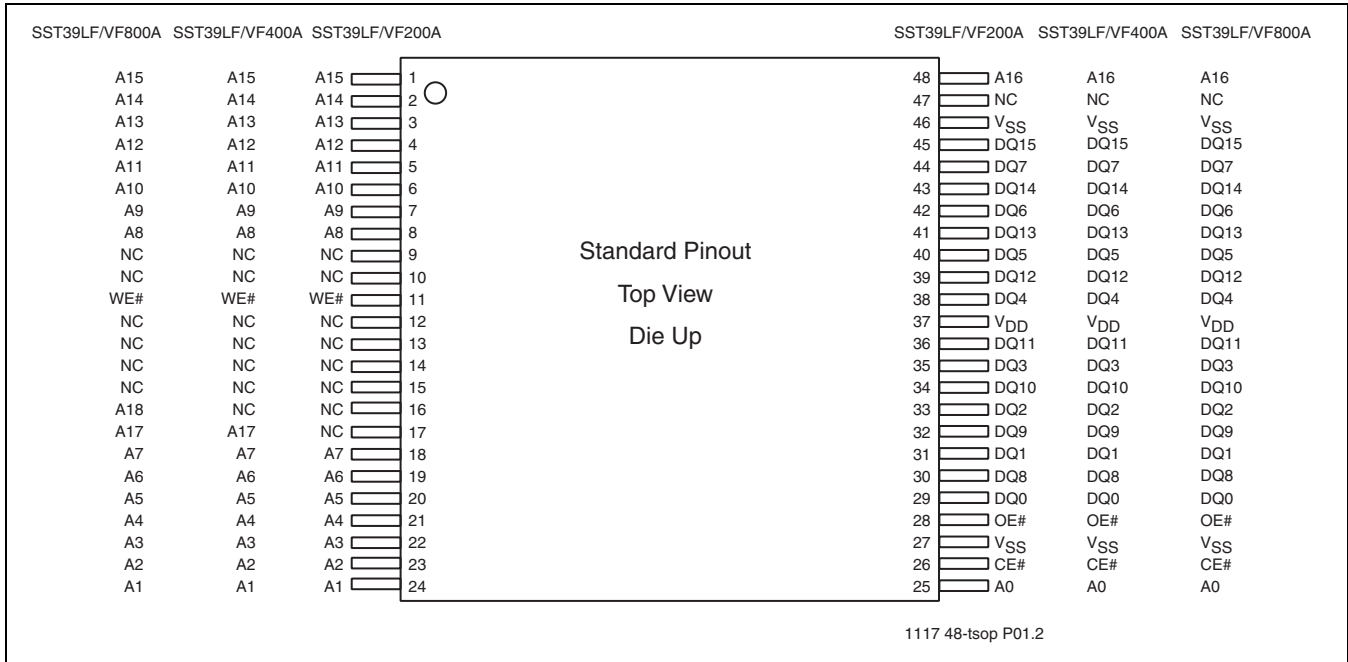

FIGURE 2: Pin Assignments for 48-Lead TSOP

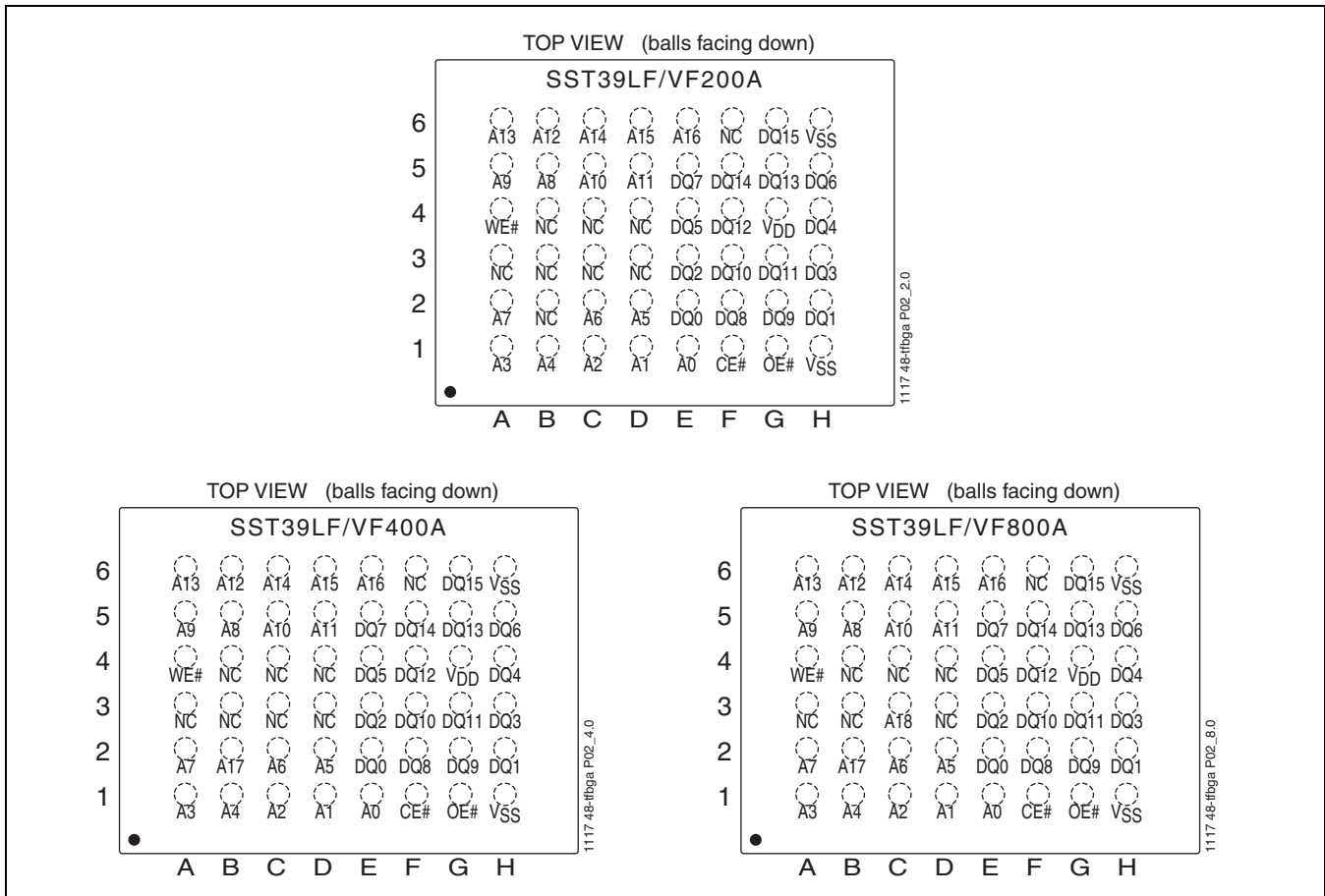

FIGURE 3: Pin Assignments for 48-Ball TFBGA



2 Mbit / 4 Mbit / 8 Mbit Multi-Purpose Flash SST39LF200A / SST39LF400A / SST39LF800A SST39VF200A / SST39VF400A / SST39VF800A

Data Sheet



FIGURE 4: Pin Assignments for 48-Ball WFBGA and 48-Bump XFLGA

2 Mbit / 4 Mbit / 8 Mbit Multi-Purpose Flash
SST39LF200A / SST39LF400A / SST39LF800A
SST39VF200A / SST39VF400A / SST39VF800A



Data Sheet

TABLE 2: Pin Description

Symbol	Pin Name	Functions
$A_{MS}^1-A_0$	Address Inputs	To provide memory addresses. During Sector-Erase $A_{MS}-A_{11}$ address lines will select the sector. During Block-Erase $A_{MS}-A_{15}$ address lines will select the block.
$DQ_{15}-DQ_0$	Data Input/output	To output data during Read cycles and receive input data during Write cycles. Data is internally latched during a Write cycle. The outputs are in tri-state when OE# or CE# is high.
CE#	Chip Enable	To activate the device when CE# is low.
OE#	Output Enable	To gate the data output buffers.
WE#	Write Enable	To control the Write operations.
V_{DD}	Power Supply	To provide power supply voltage: 3.0-3.6V for SST39LF200A/400A/800A 2.7-3.6V for SST39VF200A/400A/800A
V_{SS}	Ground	
NC	No Connection	Unconnected pins.

T2.2 1117

1. A_{MS} = Most significant address
 A_{MS} = A_{16} for SST39LF/VF200A, A_{17} for SST39LF/VF400A, and A_{18} for SST39LF/VF800A

TABLE 3: Operation Modes Selection

Mode	CE#	OE#	WE#	DQ	Address
Read	V_{IL}	V_{IL}	V_{IH}	D_{OUT}	A_{IN}
Program	V_{IL}	V_{IH}	V_{IL}	D_{IN}	A_{IN}
Erase	V_{IL}	V_{IH}	V_{IL}	X^1	Sector or Block address, XXH for Chip-Erase
Standby	V_{IH}	X	X	High Z	X
Write Inhibit	X	V_{IL}	X	High Z/ D_{OUT}	X
	X	X	V_{IH}	High Z/ D_{OUT}	X
Product Identification					
Software Mode	V_{IL}	V_{IL}	V_{IH}		See Table 4

T3.4 1117

1. X can be V_{IL} or V_{IH} , but no other value.



2 Mbit / 4 Mbit / 8 Mbit Multi-Purpose Flash SST39LF200A / SST39LF400A / SST39LF800A SST39VF200A / SST39VF400A / SST39VF800A

Data Sheet

TABLE 4: Software Command Sequence

Command Sequence	1st Bus Write Cycle		2nd Bus Write Cycle		3rd Bus Write Cycle		4th Bus Write Cycle		5th Bus Write Cycle		6th Bus Write Cycle	
	Addr ¹	Data ²	Addr ¹	Data ²	Addr ¹	Data ²	Addr ¹	Data ²	Addr ¹	Data ²	Addr ¹	Data ²
Word-Program	5555H	AAH	2AAAH	55H	5555H	A0H	WA ³	Data				
Sector-Erase	5555H	AAH	2AAAH	55H	5555H	80H	5555H	AAH	2AAAH	55H	SA _X ⁴	30H
Block-Erase	5555H	AAH	2AAAH	55H	5555H	80H	5555H	AAH	2AAAH	55H	BA _X ⁴	50H
Chip-Erase	5555H	AAH	2AAAH	55H	5555H	80H	5555H	AAH	2AAAH	55H	5555H	10H
Software ID Entry ^{5,6}	5555H	AAH	2AAAH	55H	5555H	90H						
CFI Query Entry ⁵	5555H	AAH	2AAAH	55H	5555H	98H						
Software ID Exit ⁷ / CFI Exit	XXH	F0H										
Software ID Exit ⁷ / CFI Exit	5555H	AAH	2AAAH	55H	5555H	F0H						

T4.3 1117

- Address format A₁₄-A₀ (Hex), Addresses A_{MS}-A₁₅ can be V_{IL} or V_{IH}, but no other value, for the Command sequence.
A_{MS} = Most significant address
A_{MS} = A₁₆ for SST39LF/VF200A, A₁₇ for SST39LF/VF400A, and A₁₈ for SST39LF/VF800A
- DQ₁₅-DQ₈ can be V_{IL} or V_{IH}, but no other value, for the Command sequence
- WA = Program word address
- SA_X for Sector-Erase; uses A_{MS}-A₁₁ address lines
BA_X for Block-Erase; uses A_{MS}-A₁₅ address lines
- The device does not remain in Software Product ID mode if powered down.
- With A_{MS}-A₁ = 0; SST Manufacturer's ID = 00BFH, is read with A₀ = 0,
SST39LF/VF200A Device ID = 2789H, is read with A₀ = 1.
SST39LF/VF400A Device ID = 2780H, is read with A₀ = 1.
SST39LF/VF800A Device ID = 2781H, is read with A₀ = 1.
- Both Software ID Exit operations are equivalent

TABLE 5: CFI Query Identification String¹ for SST39LF200A/400A/800A and SST39VF200A/400A/800A

Address	Data	Data
10H	0051H	Query Unique ASCII string "QRY"
11H	0052H	
12H	0059H	
13H	0001H	Primary OEM command set
14H	0007H	
15H	0000H	Address for Primary Extended Table
16H	0000H	
17H	0000H	Alternate OEM command set (00H = none exists)
18H	0000H	
19H	0000H	Address for Alternate OEM extended Table (00H = none exists)
1AH	0000H	

T5.0 1117

- Refer to CFI publication 100 for more details.

2 Mbit / 4 Mbit / 8 Mbit Multi-Purpose Flash
SST39LF200A / SST39LF400A / SST39LF800A
SST39VF200A / SST39VF400A / SST39VF800A



Data Sheet

TABLE 6: System Interface Information for SST39LF200A/400A/800A and SST39VF200A/400A/800A

Address	Data	Data
1BH	0027H ¹ 0030H ¹	V _{DD} Min (Program/Erase) DQ ₇ -DQ ₄ : Volts, DQ ₃ -DQ ₀ : 100 millivolts
1CH	0036H	V _{DD} Max (Program/Erase) DQ ₇ -DQ ₄ : Volts, DQ ₃ -DQ ₀ : 100 millivolts
1DH	0000H	V _{PP} min (00H = no V _{PP} pin)
1EH	0000H	V _{PP} max (00H = no V _{PP} pin)
1FH	0004H	Typical time out for Word-Program 2 ^N μs (2 ⁴ = 16 μs)
20H	0000H	Typical time out for min size buffer program 2 ^N μs (00H = not supported)
21H	0004H	Typical time out for individual Sector/Block-Erase 2 ^N ms (2 ⁴ = 16 ms)
22H	0006H	Typical time out for Chip-Erase 2 ^N ms (2 ⁶ = 64 ms)
23H	0001H	Maximum time out for Word-Program 2 ^N times typical (2 ¹ x 2 ⁴ = 32 μs)
24H	0000H	Maximum time out for buffer program 2 ^N times typical
25H	0001H	Maximum time out for individual Sector/Block-Erase 2 ^N times typical (2 ¹ x 2 ⁴ = 32 ms)
26H	0001H	Maximum time out for Chip-Erase 2 ^N times typical (2 ¹ x 2 ⁶ = 128 ms)

T6.2 1117

1. 0030H for SST39LF200A/400A/800A and 0027H for SST39VF200A/400A/800A

TABLE 7: Device Geometry Information for SST39LF/VF200A

Address	Data	Data
27H	0012H	Device size = 2 ^N Byte (12H = 18; 2 ¹⁸ = 256 KByte)
28H	0001H	Flash Device Interface description; 0001H = x16-only asynchronous interface
29H	0000H	
2AH	0000H	Maximum number of bytes in multi-byte write = 2 ^N (00H = not supported)
2BH		
2CH	0002H	Number of Erase Sector/Block sizes supported by device
2DH	003FH	Sector Information (y + 1 = Number of sectors; z x 256B = sector size)
2EH	0000H	
2FH	0010H	y = 63 + 1 = 64 sectors (003FH = 63)
30H	0000H	z = 16 x 256 Bytes = 4 KByte/sector (0010H = 16)
31H	0003H	Block Information (y + 1 = Number of blocks; z x 256B = block size)
32H	0000H	
33H	0000H	y = 3 + 1 = 4 blocks (0003H = 3)
34H	0001H	z = 256 x 256 Bytes = 64 KByte/block (0100H = 256)

T7.2 1117



**2 Mbit / 4 Mbit / 8 Mbit Multi-Purpose Flash
SST39LF200A / SST39LF400A / SST39LF800A
SST39VF200A / SST39VF400A / SST39VF800A**

Data Sheet

TABLE 8: Device Geometry Information for SST39LF/VF400A

Address	Data	Data
27H	0013H	Device size = 2^N Byte (13H = 19; 2^{19} = 512 KByte)
28H	0001H	Flash Device Interface description; 0001H = x16-only asynchronous interface
29H	0000H	
2AH	0000H	Maximum number of bytes in multi-byte write = 2^N (00H = not supported)
2BH	0000H	
2CH	0002H	Number of Erase Sector/Block sizes supported by device
2DH	007FH	Sector Information (y + 1 = Number of sectors; z x 256B = sector size) y = 127 + 1 = 128 sectors (007FH = 127) z = 16 x 256 Bytes = 4 KByte/sector (0010H = 16)
2EH	0000H	
2FH	0010H	
30H	0000H	
31H	0007H	Block Information (y + 1 = Number of blocks; z x 256B = block size) y = 7 + 1 = 8 blocks (0007H = 7) z = 256 x 256 Bytes = 64 KByte/block (0100H = 256)
32H	0000H	
33H	0000H	
34H	0001H	

T8.1 1117

TABLE 9: Device Geometry Information for SST39LF/VF800A

Address	Data	Data
27H	0014H	Device size = 2^N Bytes (14H = 20; 2^{20} = 1 MByte)
28H	0001H	Flash Device Interface description; 0001H = x16-only asynchronous interface
29H	0000H	
2AH	0000H	Maximum number of bytes in multi-byte write = 2^N (00H = not supported)
2BH	0000H	
2CH	0002H	Number of Erase Sector/Block sizes supported by device
2DH	00FFH	Sector Information (y + 1 = Number of sectors; z x 256B = sector size) y = 255 + 1 = 256 sectors (00FFH = 255) z = 16 x 256 Bytes = 4 KByte/sector (0010H = 16)
2EH	0000H	
2FH	0010H	
30H	0000H	
31H	000FH	Block Information (y + 1 = Number of blocks; z x 256B = block size) y = 15 + 1 = 16 blocks (000FH = 15) z = 256 x 256 Bytes = 64 KByte/block (0100H = 256)
32H	0000H	
33H	0000H	
34H	0001H	

T9.0 1117

2 Mbit / 4 Mbit / 8 Mbit Multi-Purpose Flash
SST39LF200A / SST39LF400A / SST39LF800A
SST39VF200A / SST39VF400A / SST39VF800A



Data Sheet

Absolute Maximum Stress Ratings (Applied conditions greater than those listed under “Absolute Maximum Stress Ratings” may cause permanent damage to the device. This is a stress rating only and functional operation of the device at these conditions or conditions greater than those defined in the operational sections of this data sheet is not implied. Exposure to absolute maximum stress rating conditions may affect device reliability.)

Temperature Under Bias	-55°C to +125°C
Storage Temperature	-65°C to +150°C
D. C. Voltage on Any Pin to Ground Potential	-0.5V to V _{DD} +0.5V
Transient Voltage (<20 ns) on Any Pin to Ground Potential	-2.0V to V _{DD} +2.0V
Voltage on A ₉ Pin to Ground Potential	-0.5V to 13.2V
Package Power Dissipation Capability (T _A = 25°C)	1.0W
Surface Mount Solder Reflow Temperature ¹	260°C for 10 seconds
Output Short Circuit Current ²	50 mA

1. Excluding certain with-Pb 32-PLCC units, all packages are 260°C capable in both non-Pb and with-Pb solder versions. Certain with-Pb 32-PLCC package types are capable of 240°C for 10 seconds; please consult the factory for the latest information.
2. Outputs shorted for no more than one second. No more than one output shorted at a time.

Operating Range: SST39LF200A/400A/800A

Range	Ambient Temp	V _{DD}
Commercial	0°C to +70°C	3.0-3.6V

Operating Range: SST39VF200A/400A/800A

Range	Ambient Temp	V _{DD}
Commercial	0°C to +70°C	2.7-3.6V
Industrial	-40°C to +85°C	2.7-3.6V

AC Conditions of Test

Input Rise/Fall Time	5 ns
Output Load	C _L = 30 pF for SST39LF200A/400A/800A
Output Load	C _L = 100 pF for SST39VF200A/400A/800A
See Figures 16 and 17	



2 Mbit / 4 Mbit / 8 Mbit Multi-Purpose Flash SST39LF200A / SST39LF400A / SST39LF800A SST39VF200A / SST39VF400A / SST39VF800A

Data Sheet

TABLE 10: DC Operating Characteristics

$V_{DD} = 3.0\text{-}3.6\text{V}$ for SST39LF200A/400A/800A and $2.7\text{-}3.6\text{V}$ for SST39VF200A/400A/800A¹

Symbol	Parameter	Limits			Test Conditions
		Min	Max	Units	
I _{DD}	Power Supply Current				Address input=V _{ILT} /V _{IHT} , at f=1/T _{RC} Min, V _{DD} =V _{DD} Max
	Read ²		30	mA	CE#=V _{IL} , OE#=WE#=V _{IH} , all I/Os open
	Program and Erase		30	mA	CE#=WE#=V _{IL} , OE#=V _{IH}
I _{SB}	Standby V _{DD} Current		20	μA	CE#=V _{IHC} , V _{DD} =V _{DD} Max
I _{LI}	Input Leakage Current		1	μA	V _{IN} =GND to V _{DD} , V _{DD} =V _{DD} Max
I _{LO}	Output Leakage Current		10	μA	V _{OUT} =GND to V _{DD} , V _{DD} =V _{DD} Max
V _{IL}	Input Low Voltage		0.8		V _{DD} =V _{DD} Min
V _{IH}	Input High Voltage	0.7V _{DD}		V	V _{DD} =V _{DD} Max
V _{IHC}	Input High Voltage (CMOS)	V _{DD} -0.3		V	V _{DD} =V _{DD} Max
V _{OL}	Output Low Voltage		0.2	V	I _{OL} =100 μA, V _{DD} =V _{DD} Min
V _{OH}	Output High Voltage	V _{DD} -0.2		V	I _{OH} =-100 μA, V _{DD} =V _{DD} Min

T10.7 1117

1. Typical conditions for the Active Current shown on page 1 are average values at 25°C (room temperature), and V_{DD} = 3V for VF devices. Not 100% tested.
2. Values are for 70 ns conditions. See the *Multi-Purpose Flash Power Rating* application note for further information.

TABLE 11: Recommended System Power-up Timings

Symbol	Parameter	Minimum	Units
T _{PU-READ} ¹	Power-up to Read Operation	100	μs
T _{PU-WRITE} ¹	Power-up to Program/Erase Operation	100	μs

T11.0 1117

1. This parameter is measured only for initial qualification and after a design or process change that could affect this parameter.

TABLE 12: Capacitance (T_A = 25°C, f=1 Mhz, other pins open)

Parameter	Description	Test Condition	Maximum
C _{I/O} ¹	I/O Pin Capacitance	V _{I/O} = 0V	12 pF
C _{IN} ¹	Input Capacitance	V _{IN} = 0V	6 pF

T12.0 1117

1. This parameter is measured only for initial qualification and after a design or process change that could affect this parameter.

TABLE 13: Reliability Characteristics

Symbol	Parameter	Minimum Specification	Units	Test Method
N _{END} ^{1,2}	Endurance	10,000	Cycles	JEDEC Standard A117
T _{DR} ¹	Data Retention	100	Years	JEDEC Standard A103
I _{LTH} ¹	Latch Up	100 + I _{DD}	mA	JEDEC Standard 78

T13.2 1117

1. This parameter is measured only for initial qualification and after a design or process change that could affect this parameter.
2. N_{END} endurance rating is qualified as a 10,000 cycle minimum for the whole device. A sector- or block-level rating would result in a higher minimum specification.



AC CHARACTERISTICS

TABLE 14: Read Cycle Timing Parameters $V_{DD} = 3.0-3.6V$

Symbol	Parameter	SST39LF200A/400A/800A-55		Units
		Min	Max	
T_{RC}	Read Cycle Time	55		ns
T_{CE}	Chip Enable Access Time		55	ns
T_{AA}	Address Access Time		55	ns
T_{OE}	Output Enable Access Time		30	ns
T_{CLZ}^1	CE# Low to Active Output	0		ns
T_{OLZ}^1	OE# Low to Active Output	0		ns
T_{CHZ}^1	CE# High to High-Z Output		15	ns
T_{OHZ}^1	OE# High to High-Z Output		15	ns
T_{OH}^1	Output Hold from Address Change	0		ns

T14.7 1117

1. This parameter is measured only for initial qualification and after a design or process change that could affect this parameter.

TABLE 15: Read Cycle Timing Parameters $V_{DD} = 2.7-3.6V$

Symbol	Parameter	SST39VF200A/400A/800A-70		Units
		Min	Max	
T_{RC}	Read Cycle Time	70		ns
T_{CE}	Chip Enable Access Time		70	ns
T_{AA}	Address Access Time		70	ns
T_{OE}	Output Enable Access Time		35	ns
T_{CLZ}^1	CE# Low to Active Output	0		ns
T_{OLZ}^1	OE# Low to Active Output	0		ns
T_{CHZ}^1	CE# High to High-Z Output		20	ns
T_{OHZ}^1	OE# High to High-Z Output		20	ns
T_{OH}^1	Output Hold from Address Change	0		ns

T15.7 1117

1. This parameter is measured only for initial qualification and after a design or process change that could affect this parameter.



**2 Mbit / 4 Mbit / 8 Mbit Multi-Purpose Flash
SST39LF200A / SST39LF400A / SST39LF800A
SST39VF200A / SST39VF400A / SST39VF800A**

Data Sheet

TABLE 16: Program/Erase Cycle Timing Parameters

Symbol	Parameter	Min	Max	Units
T _{BP}	Word-Program Time		20	μs
T _{AS}	Address Setup Time	0		ns
T _{AH}	Address Hold Time	30		ns
T _{CS}	WE# and CE# Setup Time	0		ns
T _{CH}	WE# and CE# Hold Time	0		ns
T _{OES}	OE# High Setup Time	0		ns
T _{OEH}	OE# High Hold Time	10		ns
T _{CP}	CE# Pulse Width	40		ns
T _{WP}	WE# Pulse Width	40		ns
T _{WPH} ¹	WE# Pulse Width High	30		ns
T _{CPH} ¹	CE# Pulse Width High	30		ns
T _{DS}	Data Setup Time	30		ns
T _{DH} ¹	Data Hold Time	0		ns
T _{IDA} ¹	Software ID Access and Exit Time		150	ns
T _{SE}	Sector-Erase		25	ms
T _{BE}	Block-Erase		25	ms
T _{SCE}	Chip-Erase		100	ms

T16.0 1117

1. This parameter is measured only for initial qualification and after a design or process change that could affect this parameter.

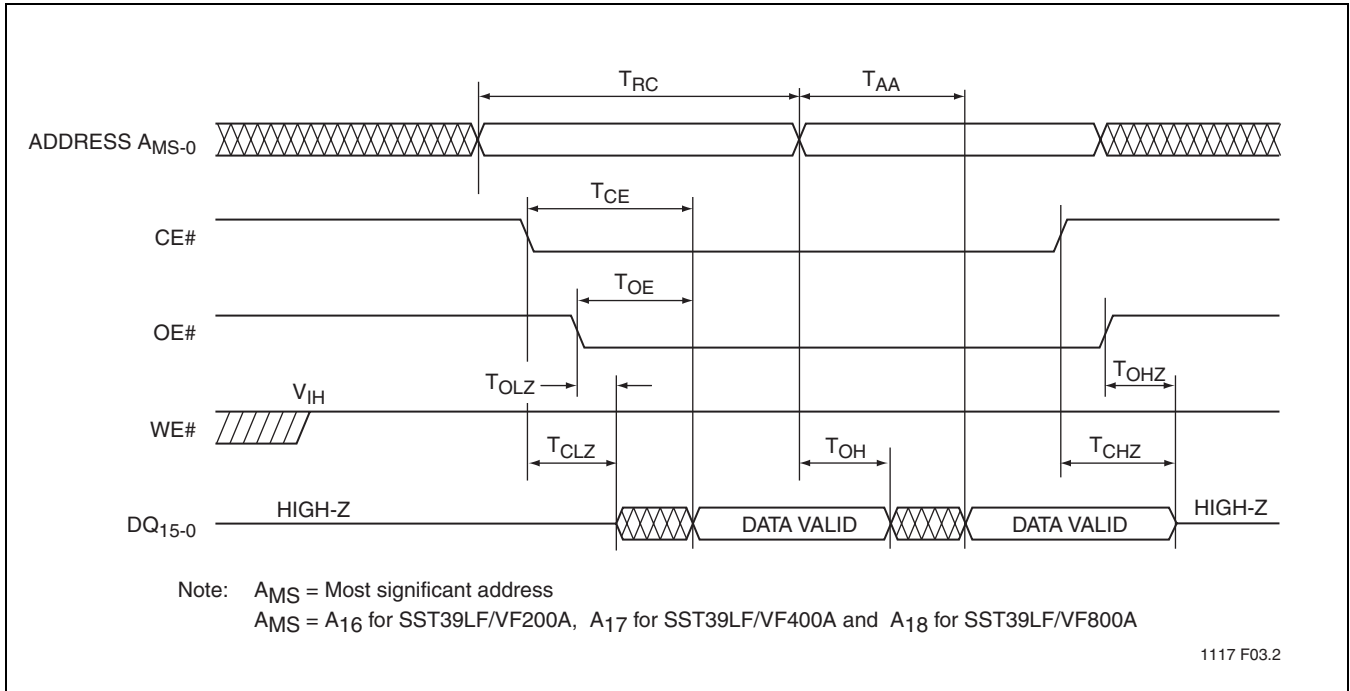

FIGURE 5: Read Cycle Timing Diagram

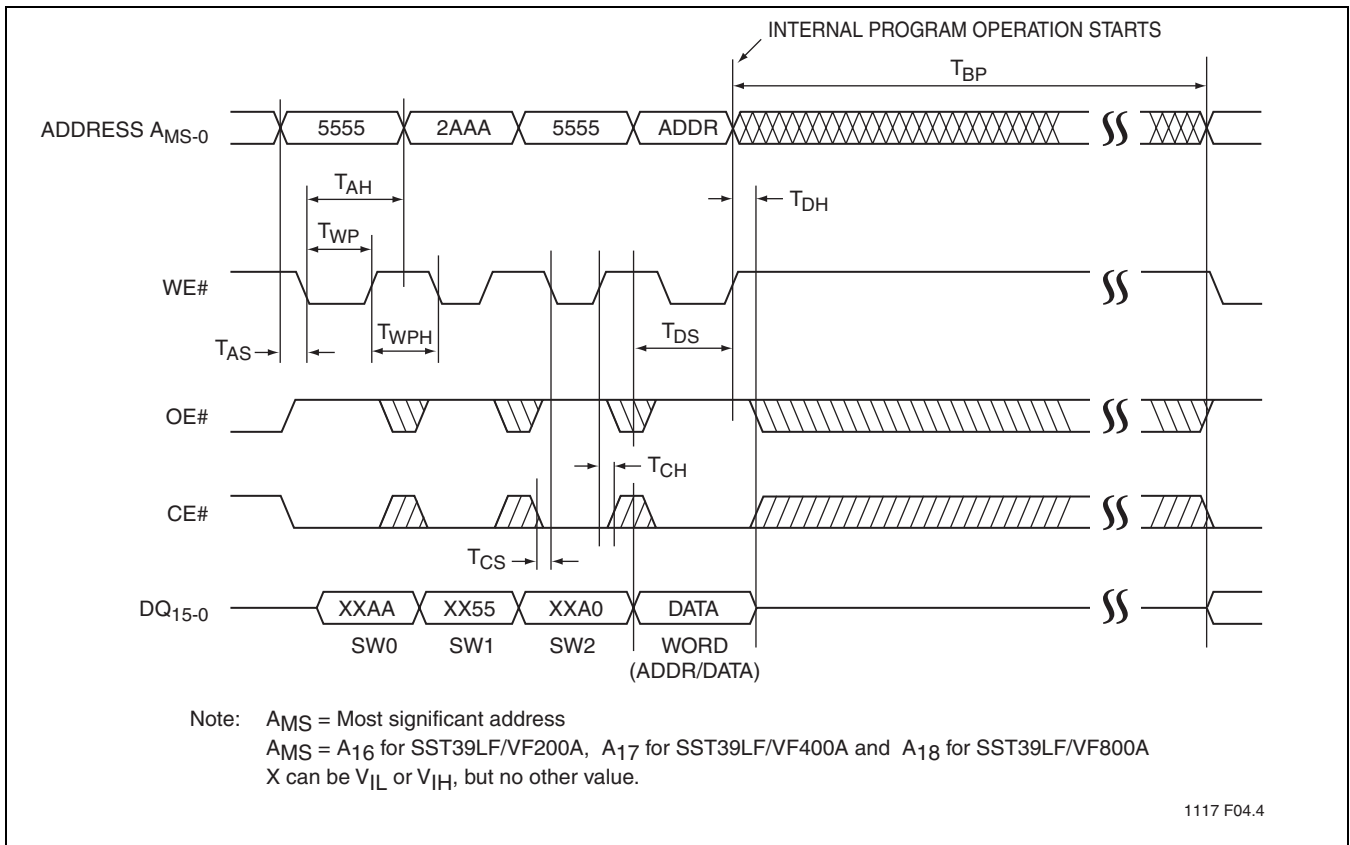

FIGURE 6: WE# Controlled Program Cycle Timing Diagram



2 Mbit / 4 Mbit / 8 Mbit Multi-Purpose Flash SST39LF200A / SST39LF400A / SST39LF800A SST39VF200A / SST39VF400A / SST39VF800A

Data Sheet

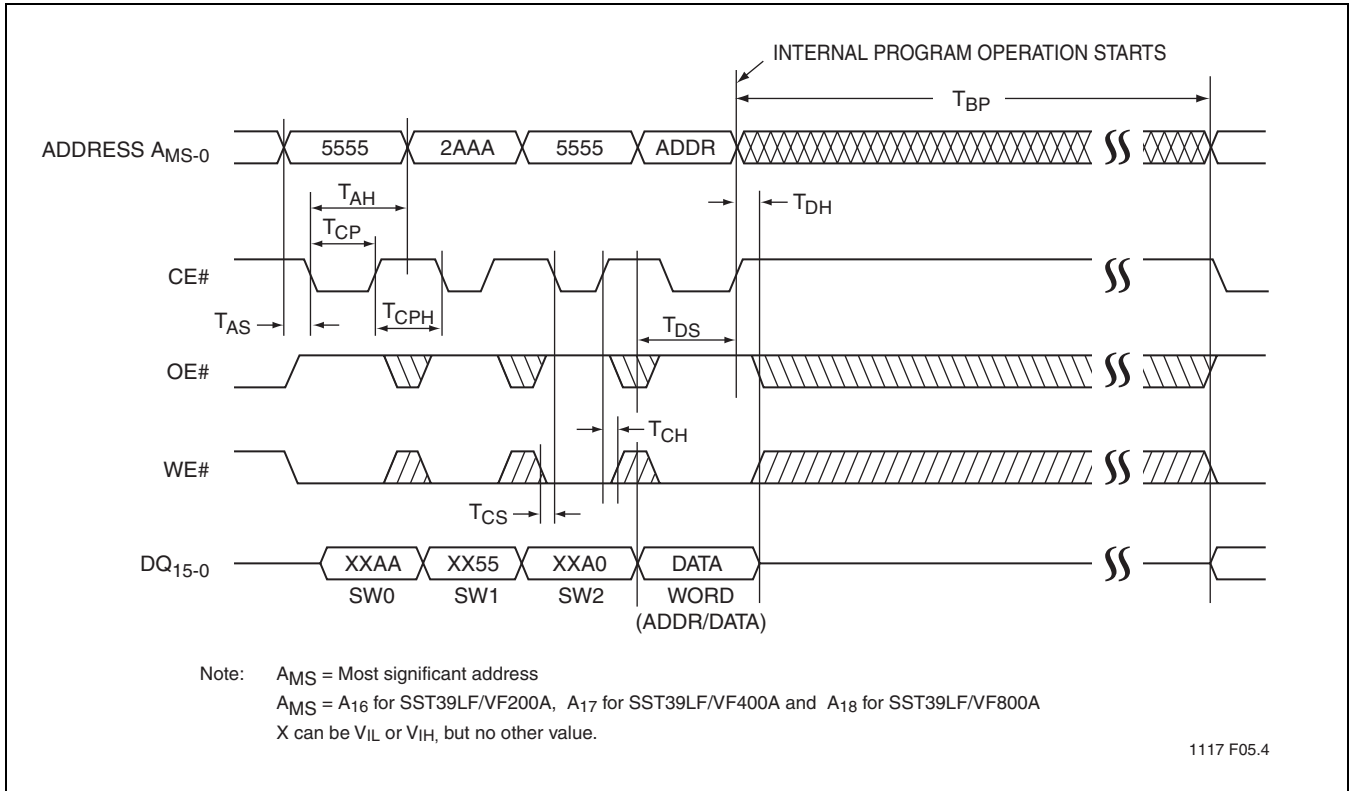

FIGURE 7: CE# Controlled Program Cycle Timing Diagram

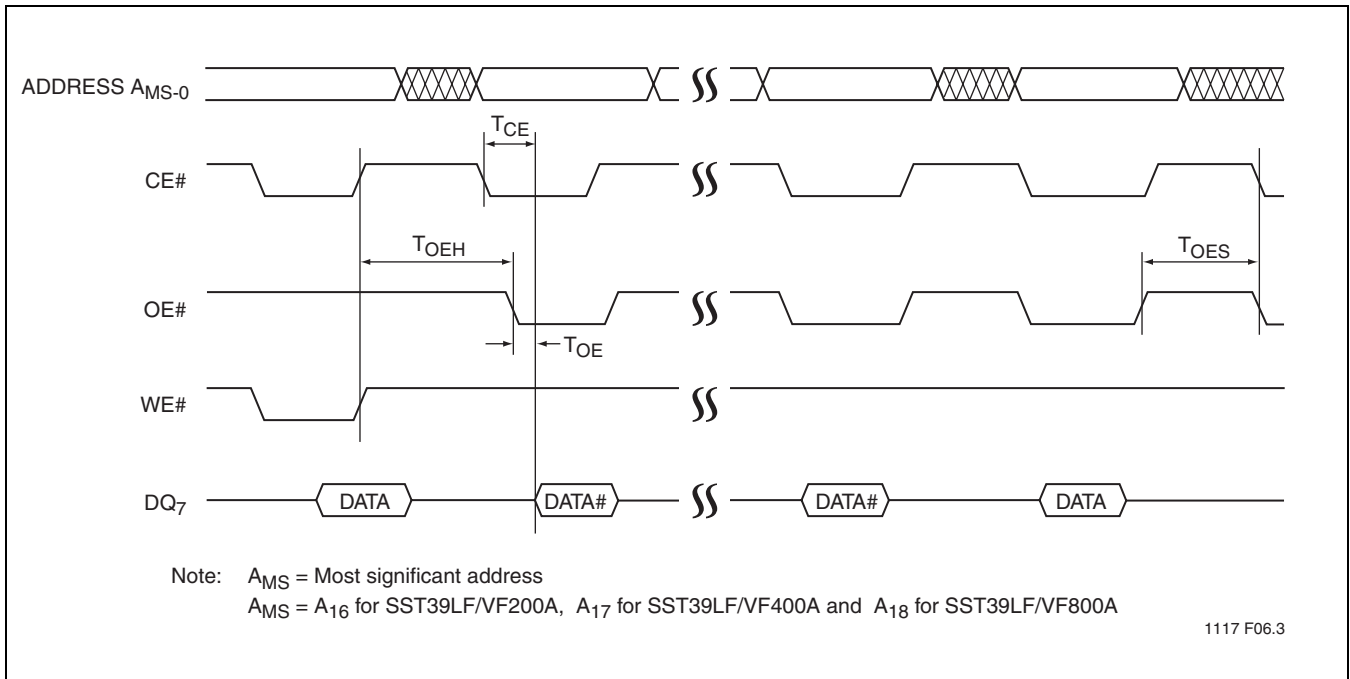

FIGURE 8: Data# Polling Timing Diagram

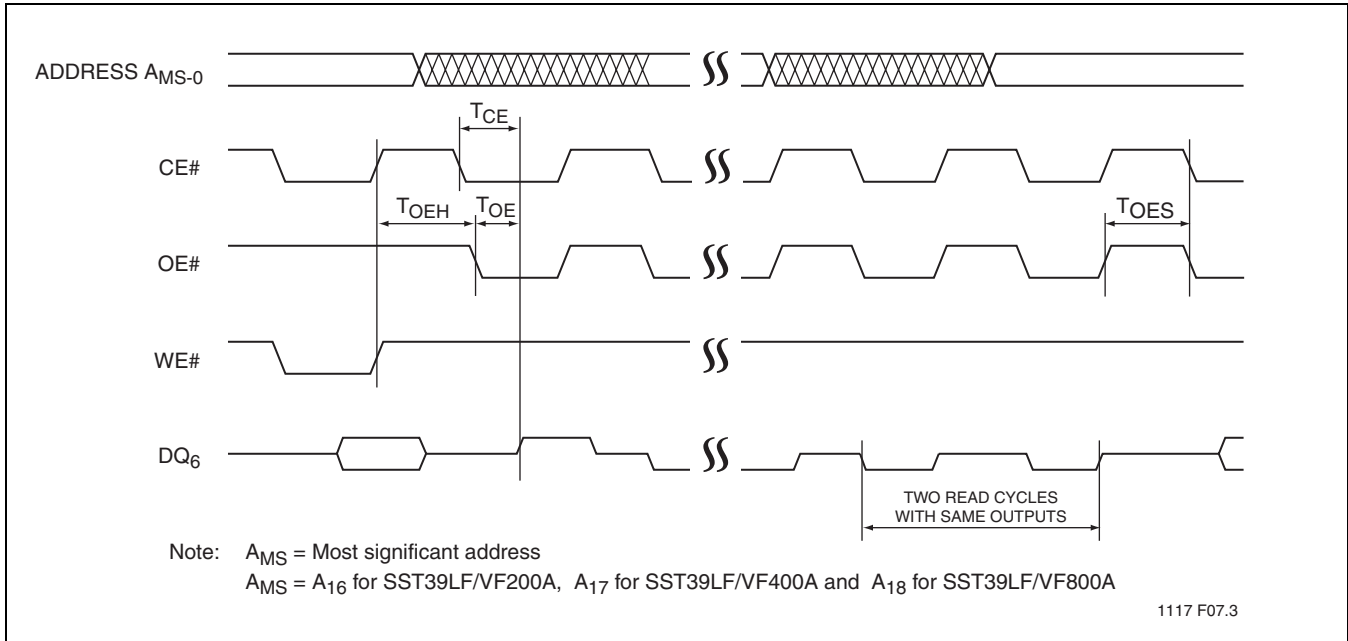

FIGURE 9: Toggle Bit Timing Diagram

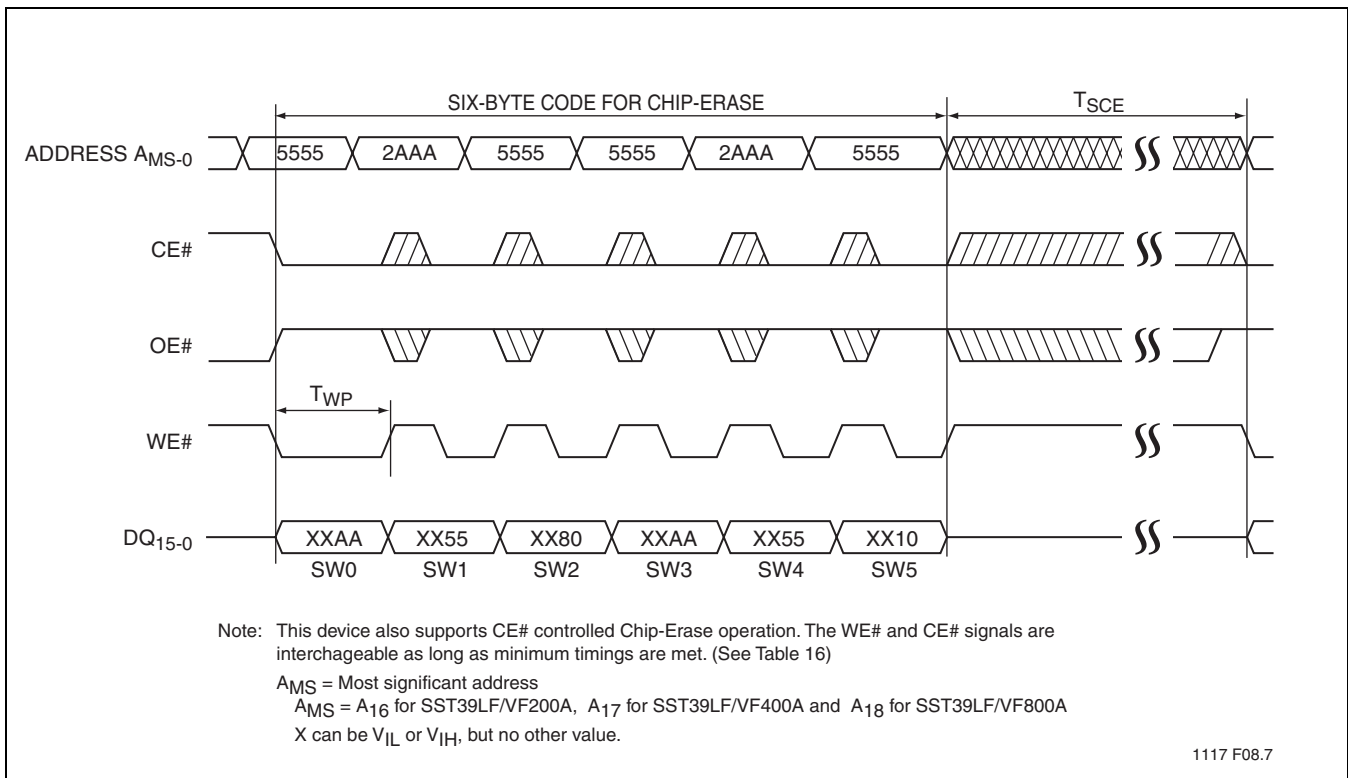

FIGURE 10: WE# Controlled Chip-Erase Timing Diagram



2 Mbit / 4 Mbit / 8 Mbit Multi-Purpose Flash SST39LF200A / SST39LF400A / SST39LF800A SST39VF200A / SST39VF400A / SST39VF800A

Data Sheet

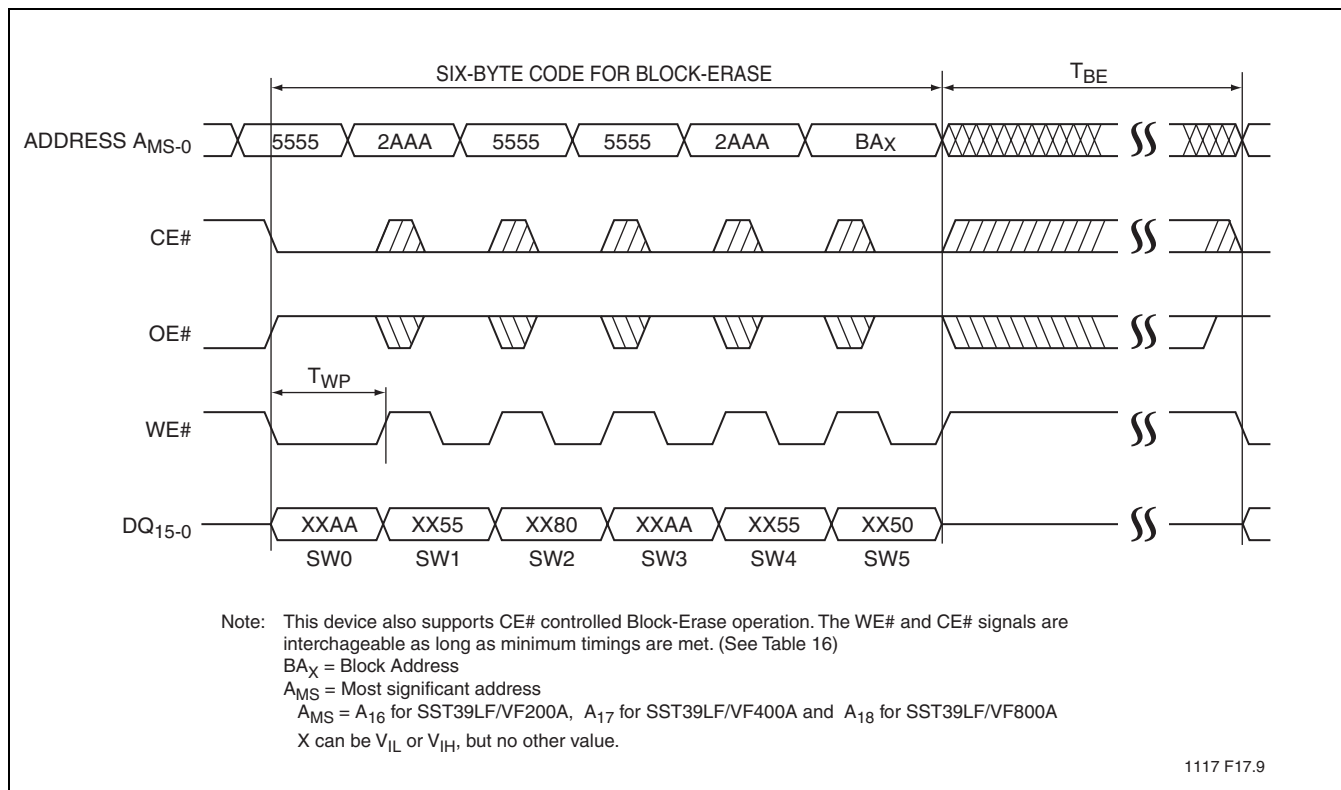

FIGURE 11: WE# Controlled Block-Erase Timing Diagram

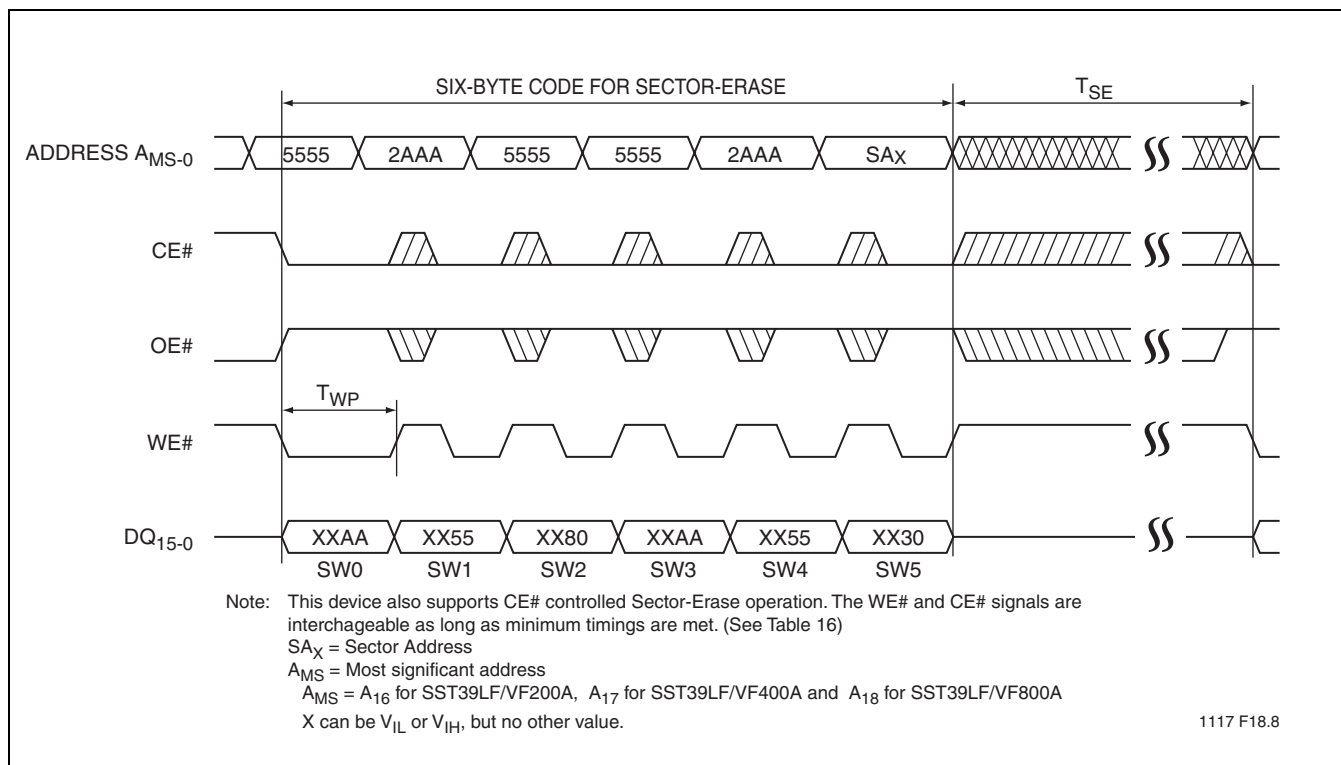

FIGURE 12: WE# Controlled Sector-Erase Timing Diagram



2 Mbit / 4 Mbit / 8 Mbit Multi-Purpose Flash SST39LF200A / SST39LF400A / SST39LF800A SST39VF200A / SST39VF400A / SST39VF800A

Data Sheet

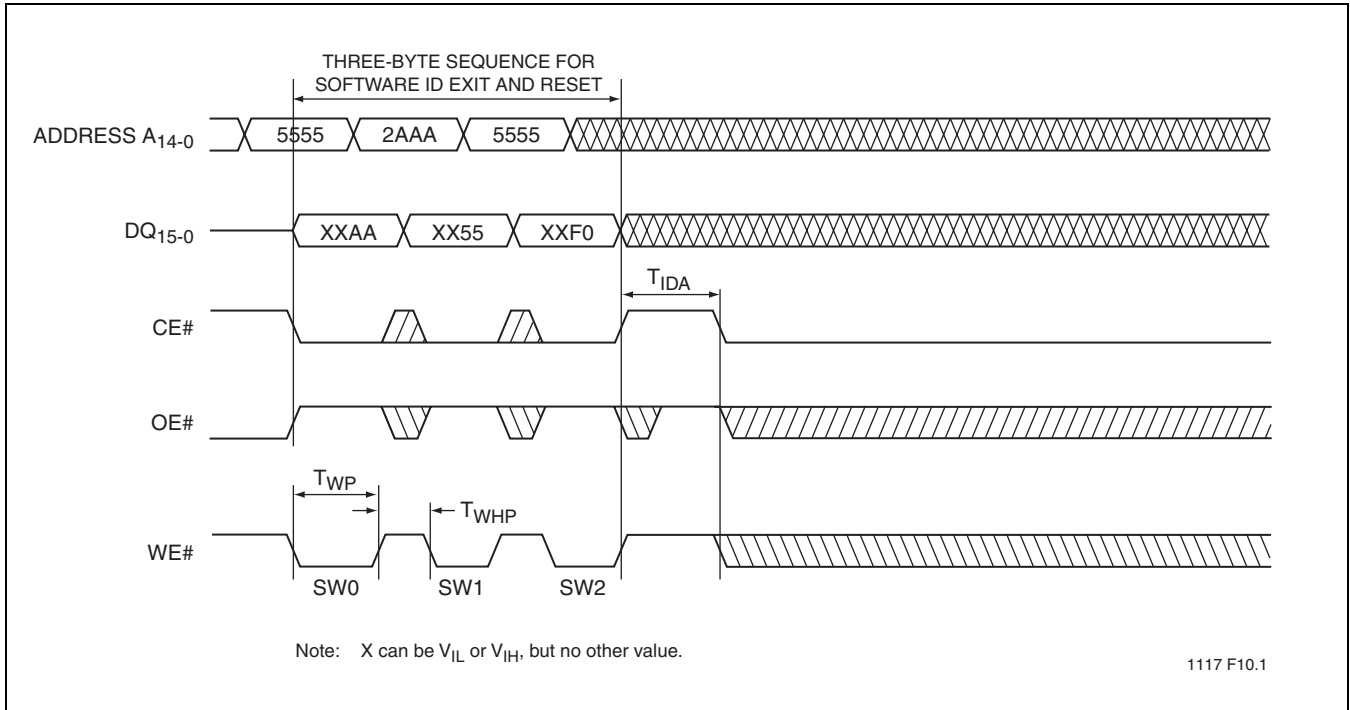

FIGURE 15: Software ID Exit/CFI Exit

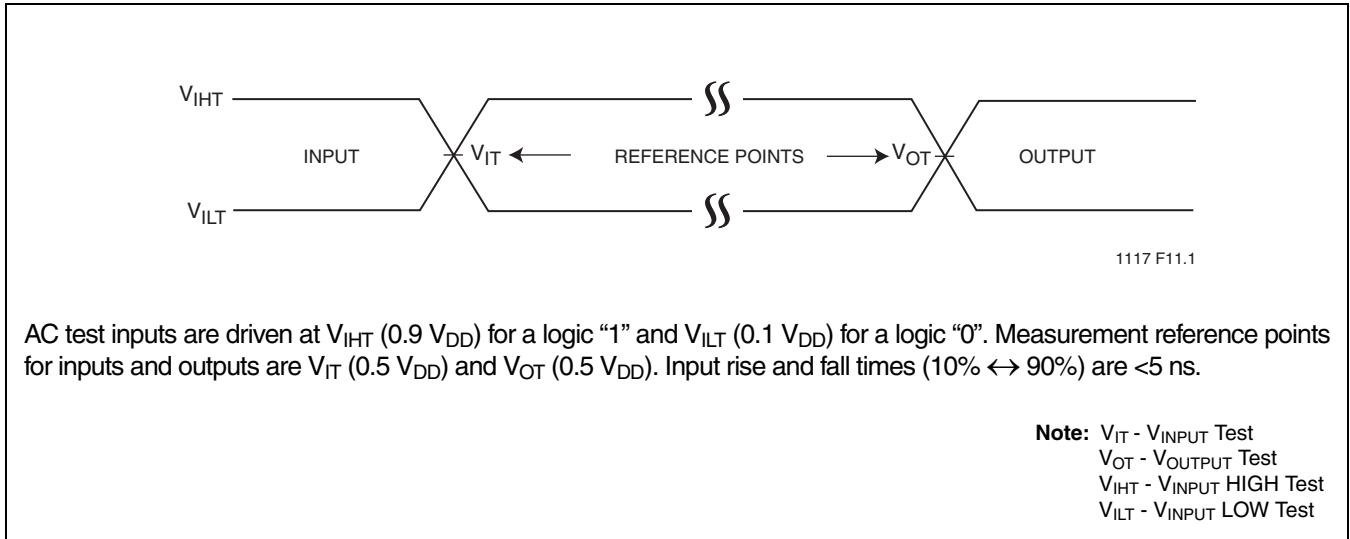

FIGURE 16: AC Input/Output Reference Waveforms

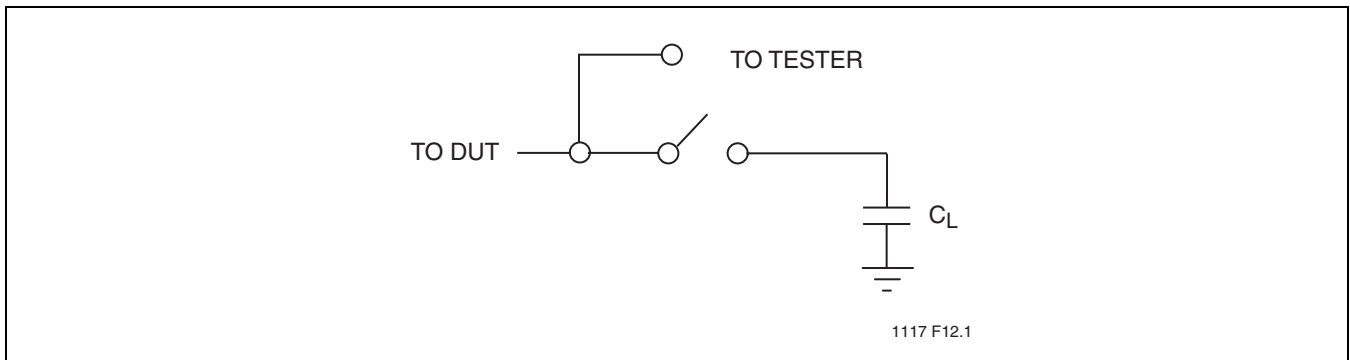

FIGURE 17: A Test Load Example

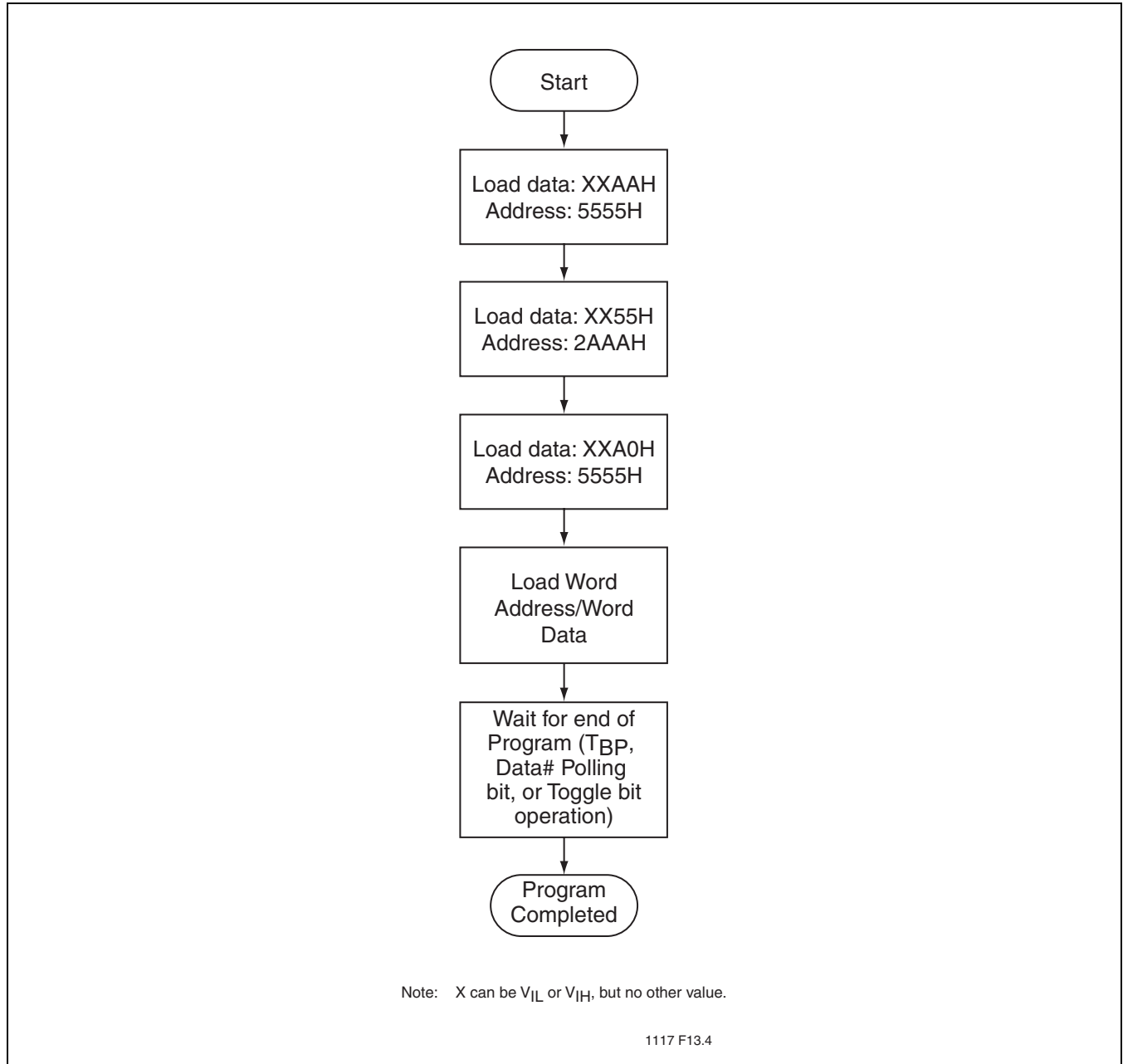

FIGURE 18: Word-Program Algorithm

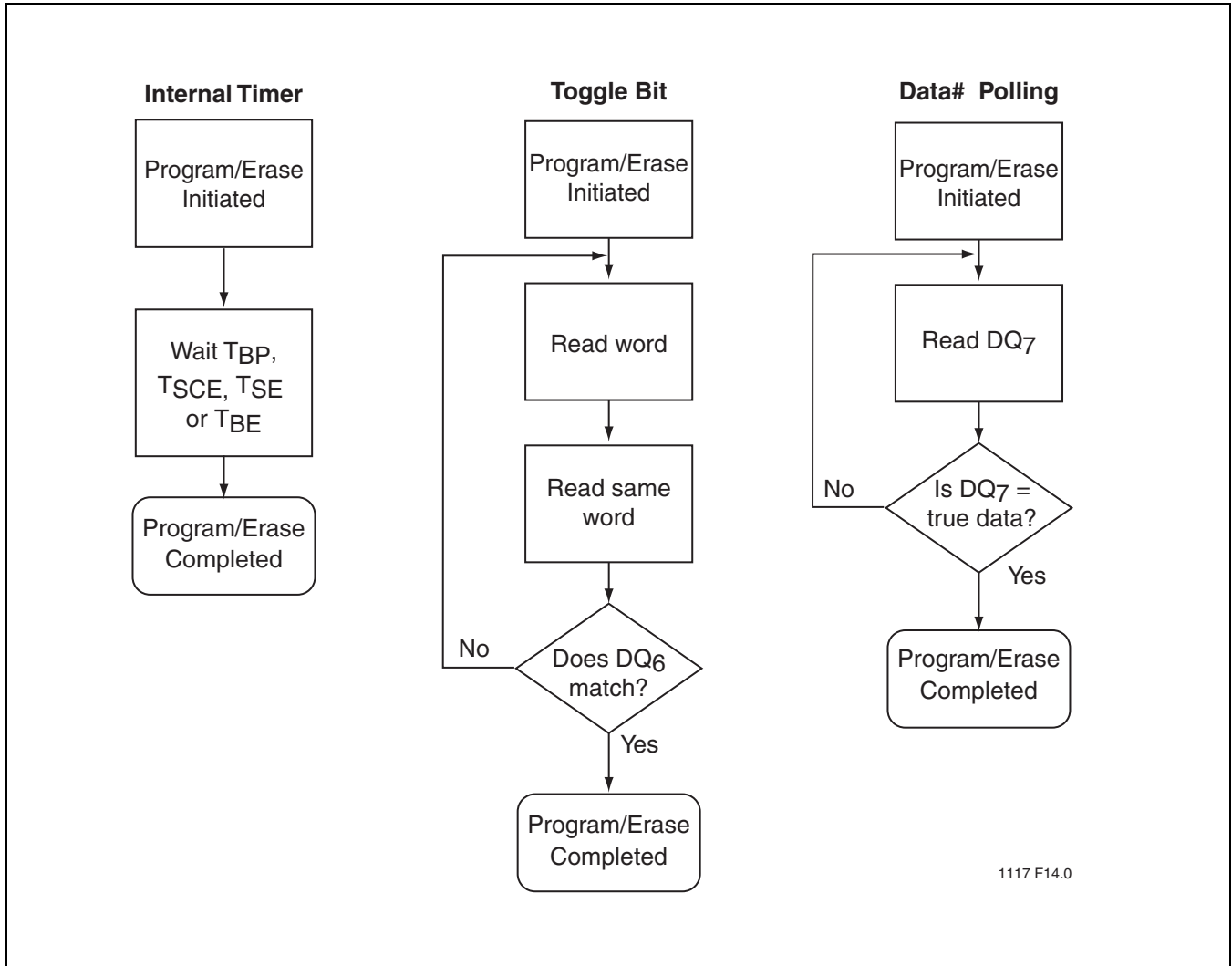

FIGURE 19: Wait Options

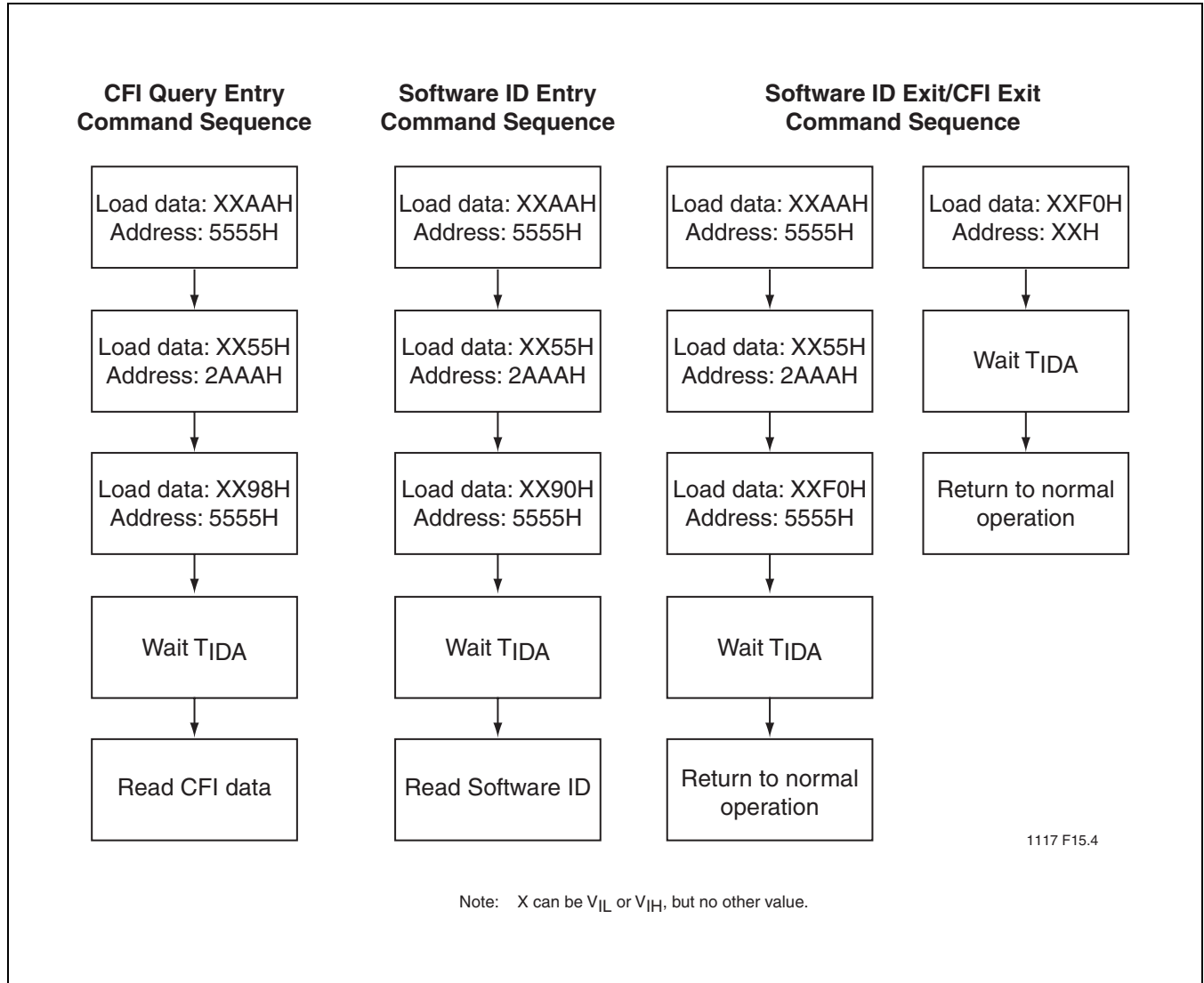

FIGURE 20: Software ID/CFI Command Flowcharts

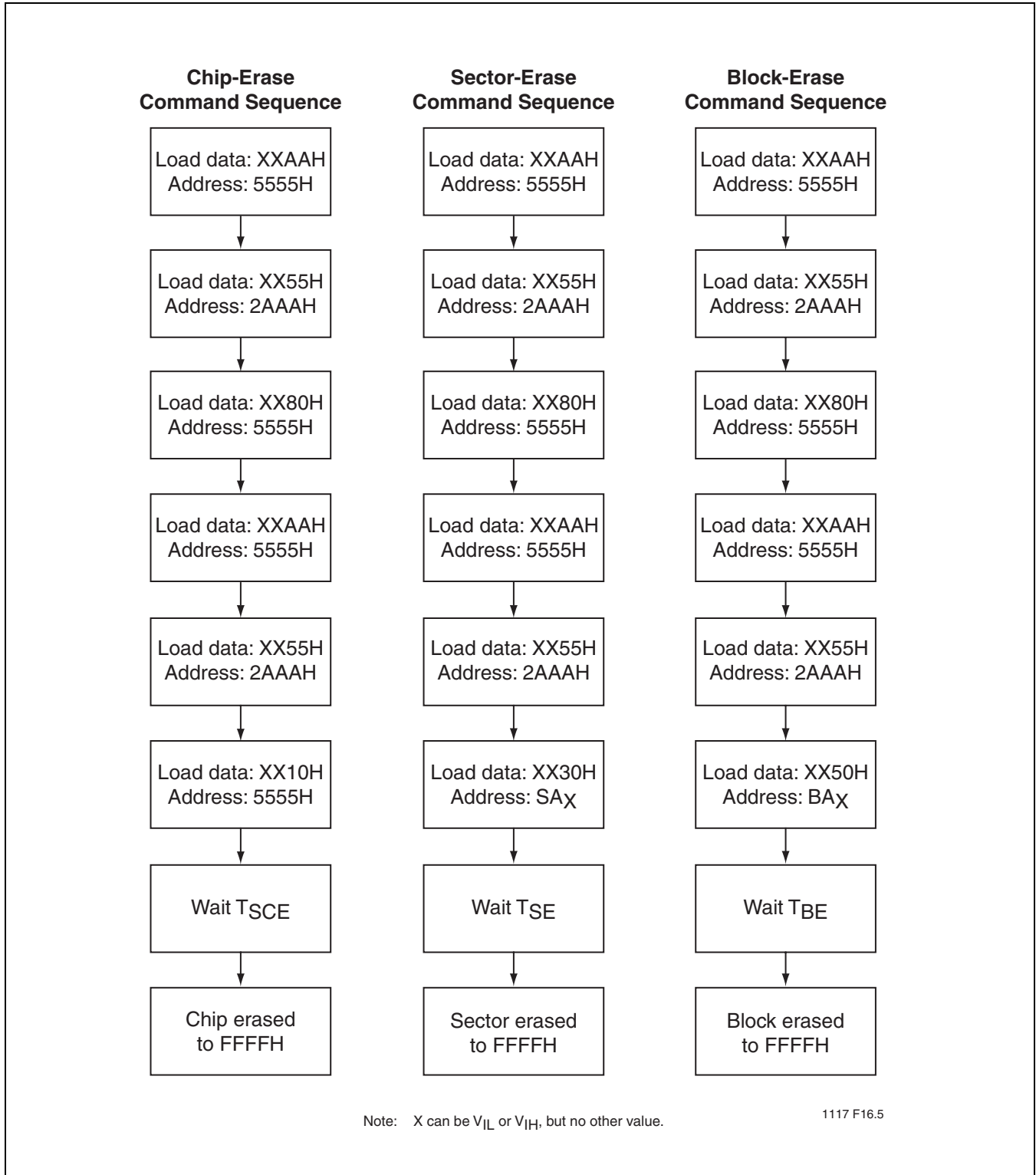

FIGURE 21: Erase Command Sequence



2 Mbit / 4 Mbit / 8 Mbit Multi-Purpose Flash
SST39LF200A / SST39LF400A / SST39LF800A
SST39VF200A / SST39VF400A / SST39VF800A

Data Sheet

PRODUCT ORDERING INFORMATION

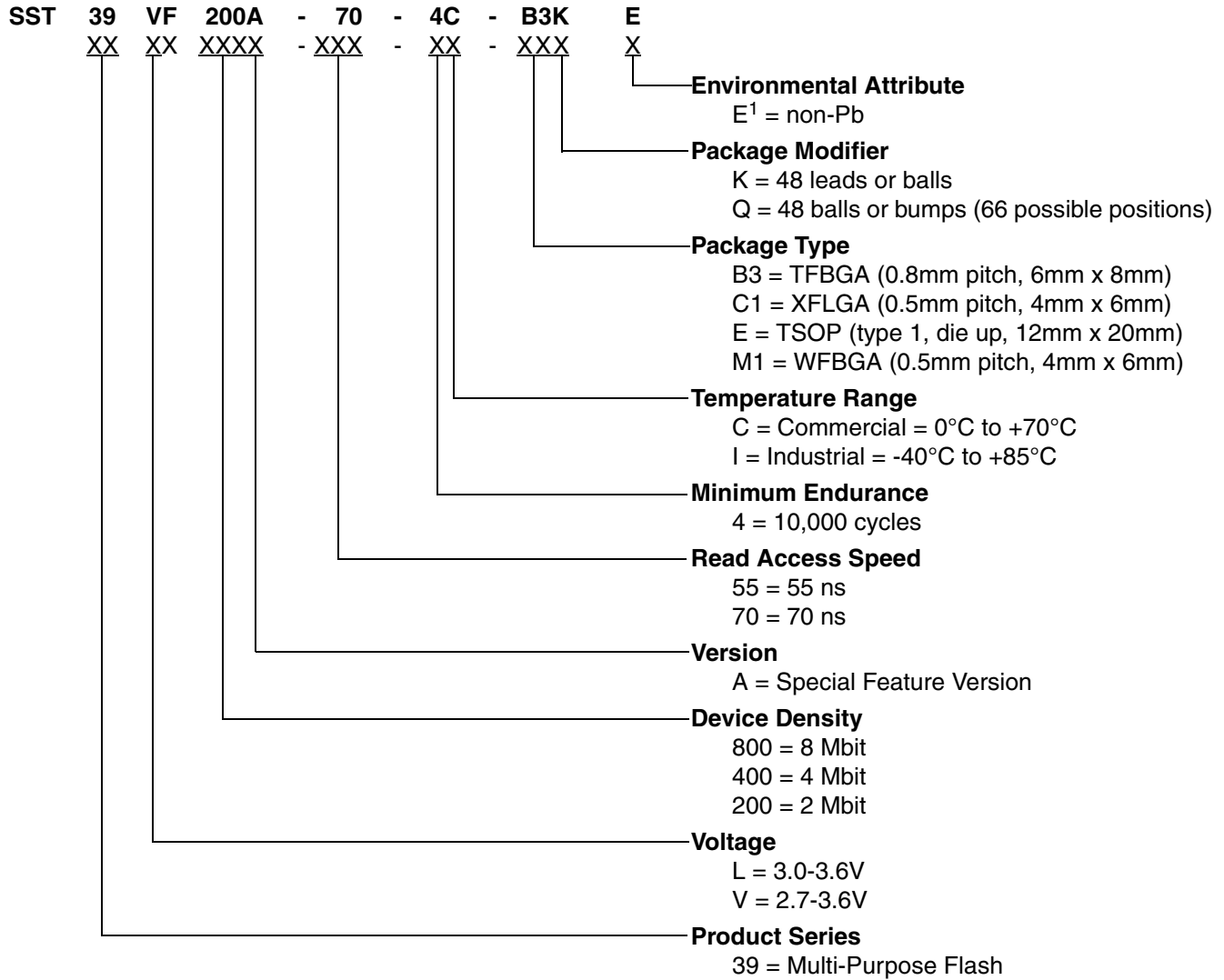

1. Environmental suffix "E" denotes non-Pb solder.
SST non-Pb solder devices are "RoHS Compliant".

**2 Mbit / 4 Mbit / 8 Mbit Multi-Purpose Flash
SST39LF200A / SST39LF400A / SST39LF800A
SST39VF200A / SST39VF400A / SST39VF800A**



Data Sheet

Valid combinations for SST39LF200A

SST39LF200A-55-4C-EKE SST39LF200A-55-4C-B3KE

Valid combinations for SST39VF200A

SST39VF200A-70-4C-EKE SST39VF200A-70-4C-B3KE SST39VF200A-70-4C-M1QE
SST39VF200A-70-4I-EKE SST39VF200A-70-4I-B3KE SST39VF200A-70-4I-M1QE

Valid combinations for SST39LF400A

SST39LF400A-55-4C-EKE SST39LF400A-55-4C-B3KE

Valid combinations for SST39VF400A

SST39VF400A-70-4C-EKE SST39VF400A-70-4C-B3KE SST39VF400A-70-4C-C1QE SST39VF400A-70-4C-M1QE
SST39VF400A-70-4I-EKE SST39VF400A-70-4I-B3KE SST39VF400A-70-4I-C1QE SST39VF400A-70-4I-M1QE

Valid combinations for SST39LF800A

SST39LF800A-55-4C-EKE SST39LF800A-55-4C-B3KE

Valid combinations for SST39VF800A

SST39VF800A-70-4C-EKE SST39VF800A-70-4C-B3KE SST39VF800A-70-4C-C1QE SST39VF800A-70-4C-M1QE
SST39VF800A-70-4I-EKE SST39VF800A-70-4I-B3KE SST39VF800A-70-4I-C1QE SST39VF800A-70-4I-M1QE

Note: Valid combinations are those products in mass production or will be in mass production. Consult your SST sales representative to confirm availability of valid combinations and to determine availability of new combinations.



2 Mbit / 4 Mbit / 8 Mbit Multi-Purpose Flash
SST39LF200A / SST39LF400A / SST39LF800A
SST39VF200A / SST39VF400A / SST39VF800A

Data Sheet

PACKAGING DIAGRAMS

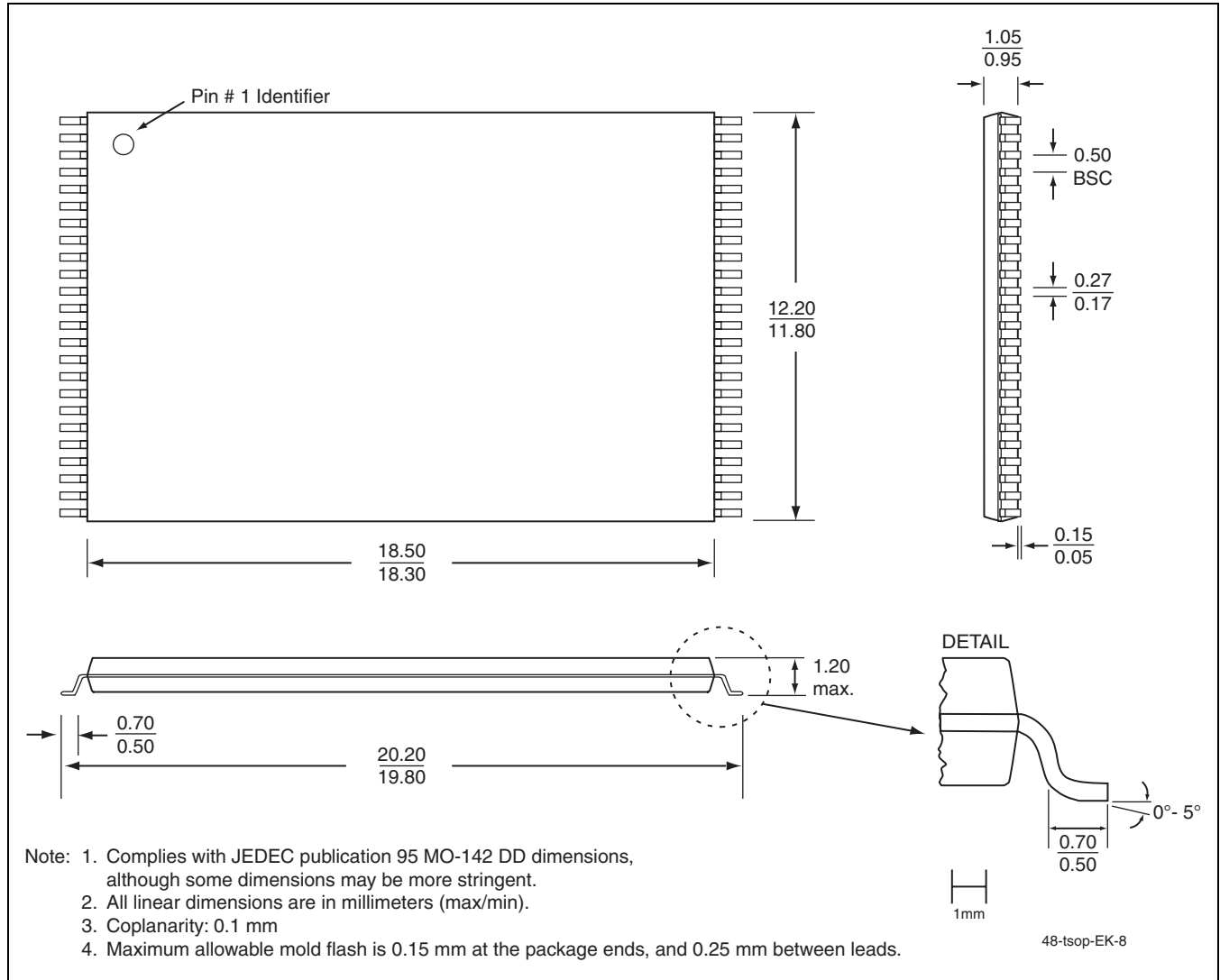

FIGURE 22: 48-Lead Thin Small Outline Package (TSOP) 12mm x 20mm
SST Package Code: EK

2 Mbit / 4 Mbit / 8 Mbit Multi-Purpose Flash
SST39LF200A / SST39LF400A / SST39LF800A
SST39VF200A / SST39VF400A / SST39VF800A



Data Sheet

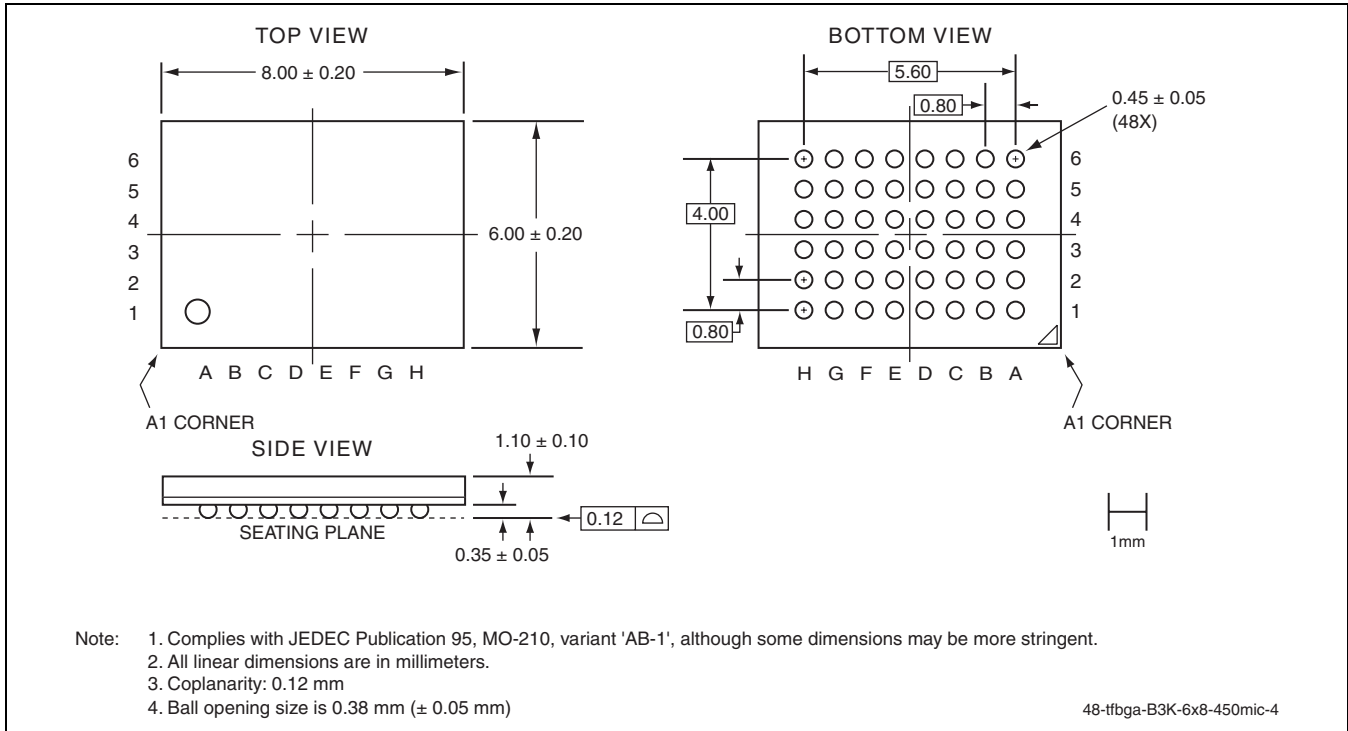

FIGURE 23: 48-Ball Thin-Profile, Fine-pitch Ball Grid Array (TFBGA) 6mm x 8mm
SST Package Code: B3K

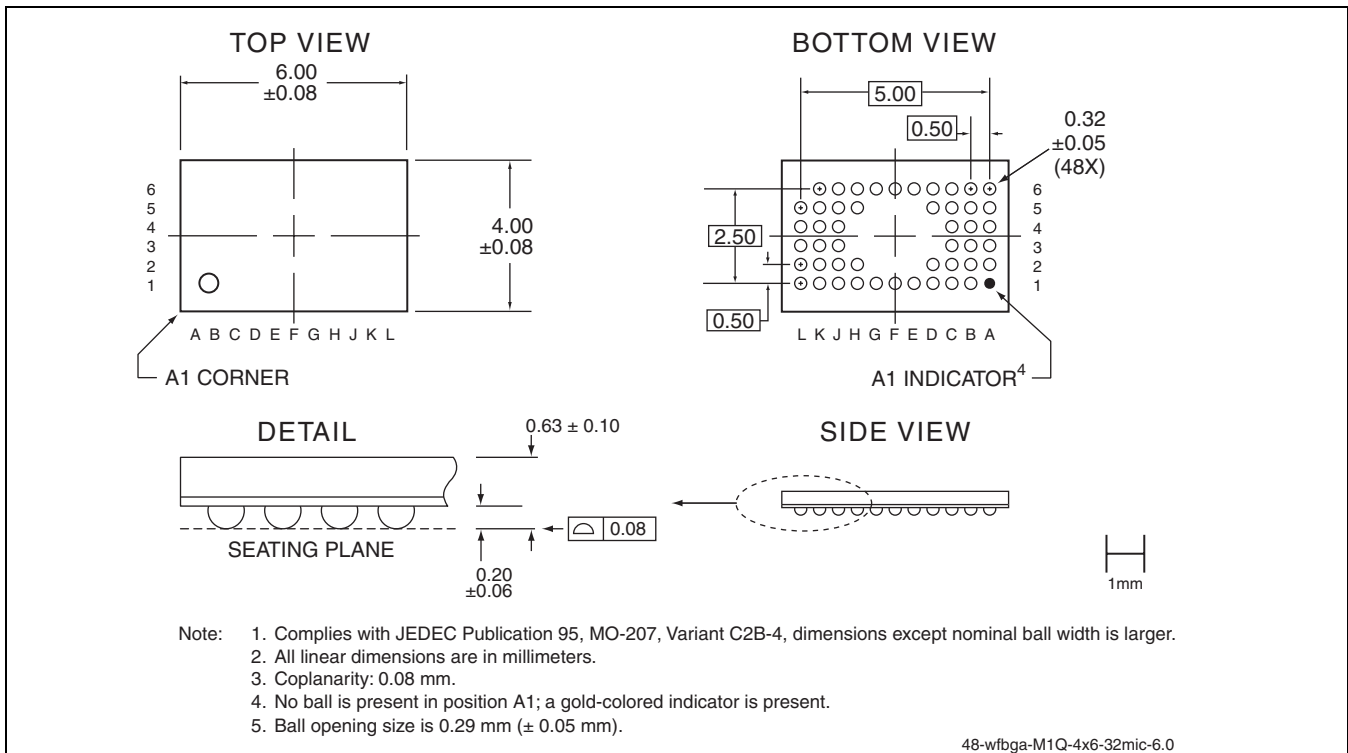
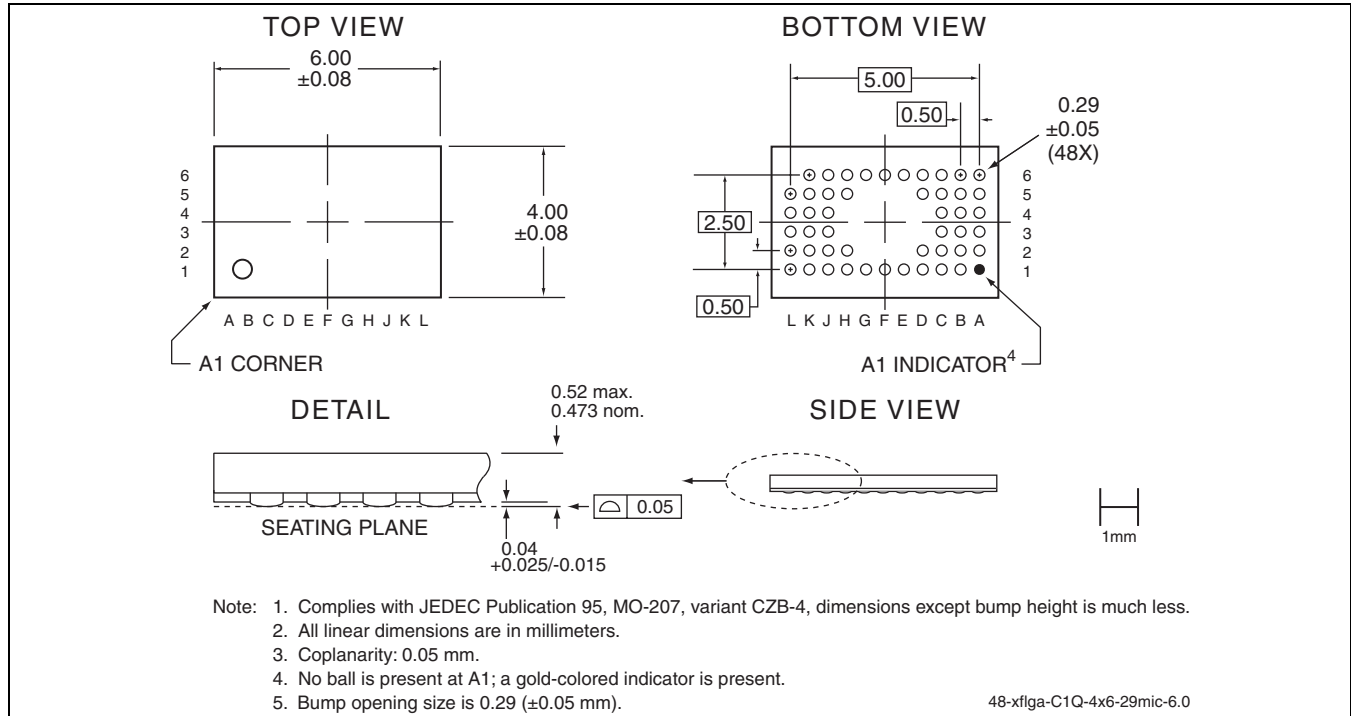

FIGURE 24: 48-Ball Very-Very-Thin-Profile, Fine-Pitch Ball Grid Array (WFBGA) 4mm x 6mm
SST Package Code: M1Q



2 Mbit / 4 Mbit / 8 Mbit Multi-Purpose Flash
 SST39LF200A / SST39LF400A / SST39LF800A
 SST39VF200A / SST39VF400A / SST39VF800A

Data Sheet



**FIGURE 25: 48-Bump Extremely-Thin-Profile, Fine-Pitch Land Grid Array (XFLGA) 4mm x 6mm
 SST Package Code: C1Q**

2 Mbit / 4 Mbit / 8 Mbit Multi-Purpose Flash
SST39LF200A / SST39LF400A / SST39LF800A
SST39VF200A / SST39VF400A / SST39VF800A



Data Sheet

TABLE 17: Revision History

Number	Description	Date
04	<ul style="list-style-type: none"> 2002 Data Book 	May 2002
05	<ul style="list-style-type: none"> Added footnotes for MPF power usage and Typical conditions to Table 10 on page 12 Clarified the Test Conditions for Power Supply Current and Read parameters in Table 10 on page 12 Part number changes - see page 27 for additional information New Micro-Package part numbers added for SST39VF400A and SST39VF800A 	Mar 2003
06	<ul style="list-style-type: none"> New Micro-Package part numbers added for SST39VF400A / 800A (see page 27) 	Oct 2003
07	<ul style="list-style-type: none"> 2004 Data Book Updated the B3K, M1Q, and C1Q package diagrams Added non-Pb MPNs and removed footnote (see page 27) 	Nov 2003
08	<ul style="list-style-type: none"> Added M1Q/M1QE MPNs for the SSTVF200A device on page 27 Removed 90ns MPNs and footnote for the SSTVFX00A devices on page 27 Added RoHS compliance information on page 1 and in the "Product Ordering Information" on page 26 Clarified the solder temperature profile under "Absolute Maximum Stress Ratings" on page 11. 	Apr 2005
09	<ul style="list-style-type: none"> Removed valid combinations SST39LF400A-45-4C-EK, SST39LF400A-45-4C-B3K, SST39LF400A-45-4C-EKE, and SST39LF400A-45-4C-B3KE due to EOL Applied new format styles. 	Feb 2007
10	<ul style="list-style-type: none"> Add Y1QE package Removed all pb parts 	Aug 2007
11	<ul style="list-style-type: none"> EOL of all Y1QE parts. Replacement parts are M1QE parts in this document. 	Dec 2009
12	<ul style="list-style-type: none"> EOL of SST39LF200A-45-4C-EKE and SST39LF200A-45-4C-B3KE. See S71117(12). Replacement parts are SST39LF200A-55-4C-EKE and SST39LF200A-55-4C-B3KE found in this document. 	Apr 2010

Silicon Storage Technology, Inc.
www.SuperFlash.com or www.sst.com