

The SST49LF016C flash memory device is designed to interface with host controllers (chipsets) that support a low pin-count (LPC) interface for system firmware applications. Complying with LPC Interface Specification 1.1, SST49LF016C supports a Burst-Read data transfer of 15.6 MBytes per second at 33 MHz clock speed and 31.2 MBytes per second at 66 MHz clock speed, up to 128 bytes in a single operation

Features

- **Operational Clock Frequency**
 - 33 MHz
 - 66 MHz
- **Organized as 2M x8**
- **Conforms to LPC Interface Specification v1.1**
 - Support Multi-Byte Firmware Memory Read/Write Cycles
- **Single 3.0-3.6V Read and Write Operations**
- **LPC Mode**
 - 5-signal LPC bus interface for both in-system and factory programming using programmer equipment
 - Multi-Byte Read data transfer rate
 - 15.6 MB/s @ 33 MHz PCI clock and
 - 31.2 MB/s @ 66 MHz clock
 - Firmware Memory Read cycle supporting
 - 1, 2, 4, 16, and 128 Byte Read
 - Firmware Memory Write cycle supporting
 - 1, 2, and 4 Byte Write
 - 33 MHz/66 MHz clock frequency operation
 - WP#/AAI and TBL# pins provide hardware Write protect for entire chip and/or top Boot Block
 - Block Locking Registers for individual block Read-Lock, Write-Lock, and Lock-Down protection
 - 5 GPI pins for system design flexibility
 - 4 ID pins for multi-chip selection
 - Multi-Byte capability registers (read-only registers)
 - Status register for End-of-Write detection
 - Program-/Erase-Suspend
 - Read or Write to other blocks during Program-/Erase-Suspend
- **Two-cycle Command Set**
- **Security ID Feature**
 - 256-bit Secure ID space
 - 64-bit Unique Factory Pre-programmed Device Identifier
 - 192-bit User-Programmable OTP
- **Superior Reliability**
 - Endurance: 100,000 Cycles (typical)
 - Greater than 100 years Data Retention
- **Low Power Consumption**
 - Active Read Current: 12 mA (typical)
 - Standby Current: 10 μ A (typical)
- **Uniform 4 KByte sectors**
 - 35 Overlay Blocks: one 16-KByte Boot Block, two 8-KByte Parameter Blocks, one 32-Kbyte Parameter Block, thirty-one 64-KByte Main Blocks.
- **Fast Sector-Erase/Program Operation**
 - Sector-Erase Time: 18 ms (typical)
 - Block-Erase Time: 18 ms (typical)
 - Program Time: 7 μ s (typical)
- **Auto Address Increment (AAI) for Rapid Factory Programming (High Voltage Enabled)**
 - RY/BY# pin for End-of-Write detection
 - Multi-Byte Program
 - Chip Rewrite Time: 4 seconds (typical)
- **Packages Available**
 - 32-lead PLCC
 - 32-lead TSOP (8mm x 14mm)
 - 40-lead TSOP (10mm x 20mm)
- **All devices are RoHS compliant**

Product Description

The SST49LF016C flash memory device is designed to interface with host controllers (chipsets) that support a low-pin-count (LPC) interface for system firmware applications. Complying with LPC Interface Specification 1.1, SST49LF016C supports a Burst-Read data transfer of 15.6 MBytes per second at 33 MHz clock speed and 31.2 MBytes per second at 66 MHz clock speed, up to 128 bytes in a single operation.

The LPC interface operates with 5 signal pins versus 28 pins of a 8-bit parallel flash memory. This frees up pins on the ASIC host controller resulting in lower ASIC costs and a reduction in overall system costs due to simplified signal routing. This 5-signal LPC interface supports both in-system and rapid factory programming using programmer equipment. A high voltage pin (WP#/AAI) enables Auto Address Increment (AAI) mode.

Via the software registers, the SST49LF016C offers hardware block protection and individual block protection for critical system code and data. The 256-bit Security ID space is comprised of a 64-bit factory pre-programmed unique number and a 192-bit One-Time-Programmable (OTP) area. This Security ID permits the use of new security techniques and implementation of a new data protection scheme. To protect against inadvertent write, the SST49LF016C device has on-chip hardware and software write protection schemes. The SST49LF016C also provides general purpose inputs (GPI) for system design flexibility.

Manufactured with SST proprietary, high-performance SuperFlash technology, SST49LF016C has a split-gate cell design and thick-oxide tunneling injector for greater reliability and manufacturability compared with alternative technology approaches.

The SST49LF016C significantly improves performance and reliability, while lowering power consumption. The total energy consumed is a function of the applied voltage, current and time of application. Because the SST49LF016C writes in-system with a single 3.0-3.6V power supply, the total energy consumed during any Erase or Program operation is less than alternative flash memory technologies.

The SuperFlash technology provides fixed Erase and Program time, independent of the number of Erase/Program cycles performed. This feature eliminates system software or hardware calibration or erase cycle correlation which is necessary with alternative flash memory technologies, whose Erase and Program time increase with accumulated Erase/Program cycles.

The SST49LF016C product provides a maximum program time of 10 μ s per byte with a single-byte Program operation; effectively 5 μ s per byte with a dual-byte Program operation and 2.5 μ s per byte with a quad-byte Program operation.

The SST49LF016C is offered in 32-PLCC, 32-TSOP, and 40-TSOP packages. See Figures 3, 4, and 5 for pin assignments and Table 1 for pin descriptions.

Functional Blocks

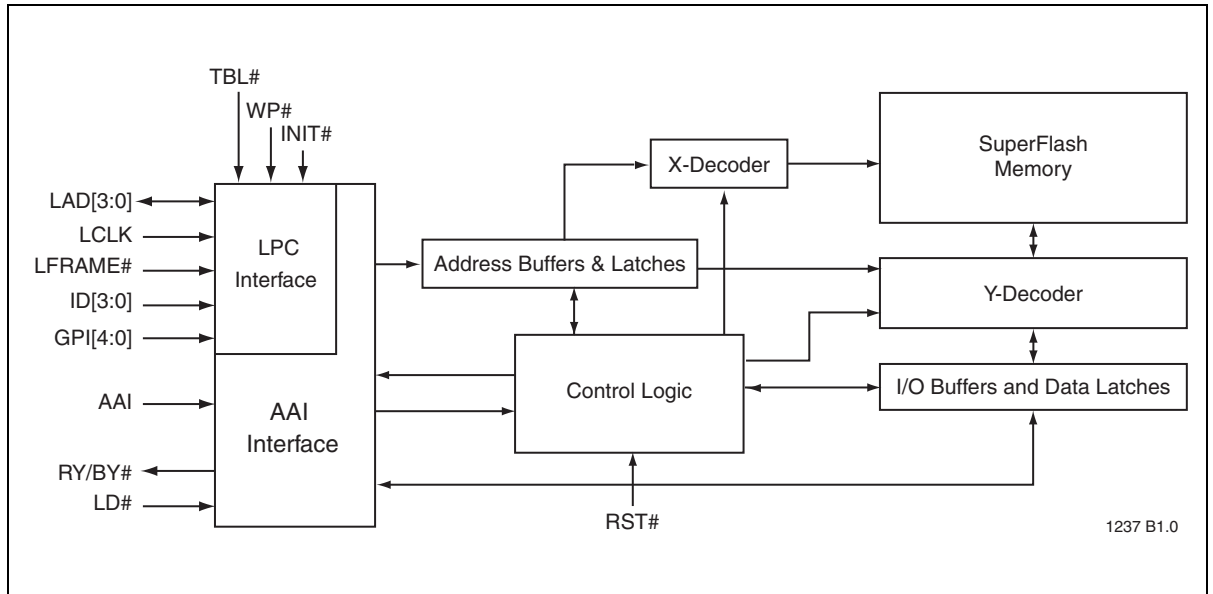

Figure 1: Functional Block Diagram

Device Memory Map

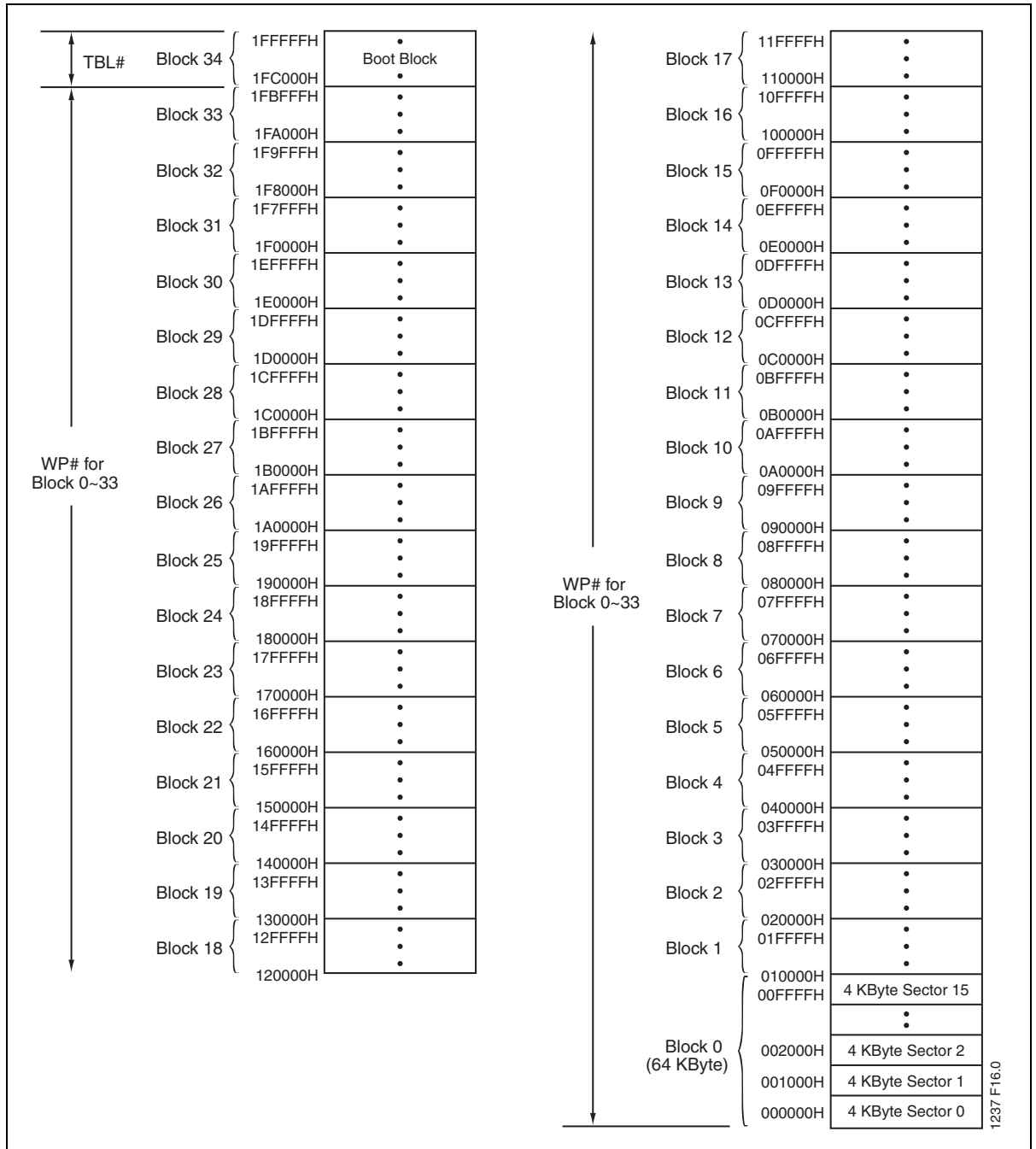

Figure 2: Device Memory Map for SST49LF016C

Pin Assignments

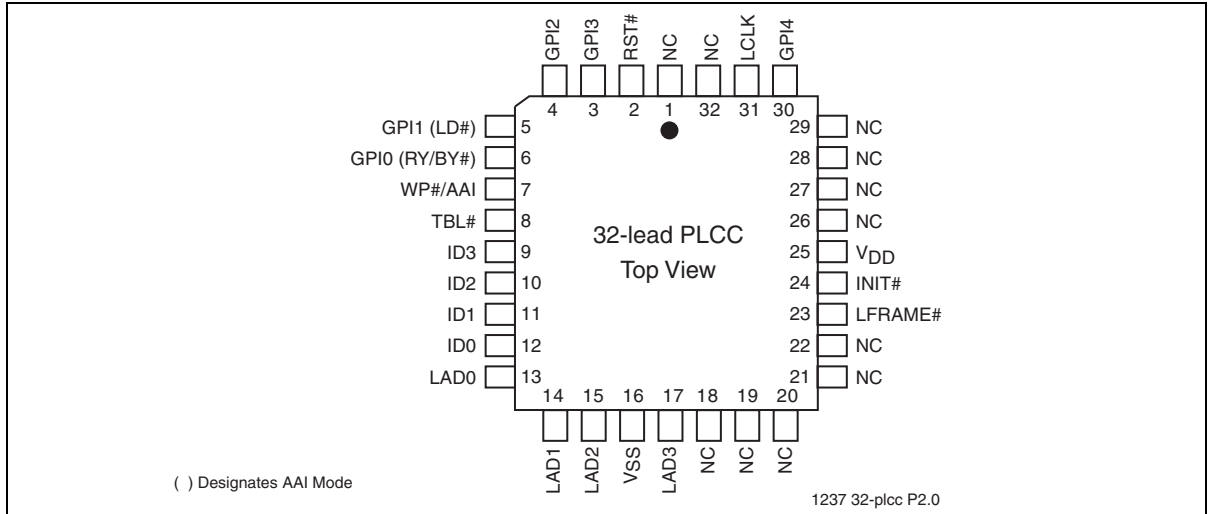

Figure 3: Pin Assignments for 32-lead PLCC

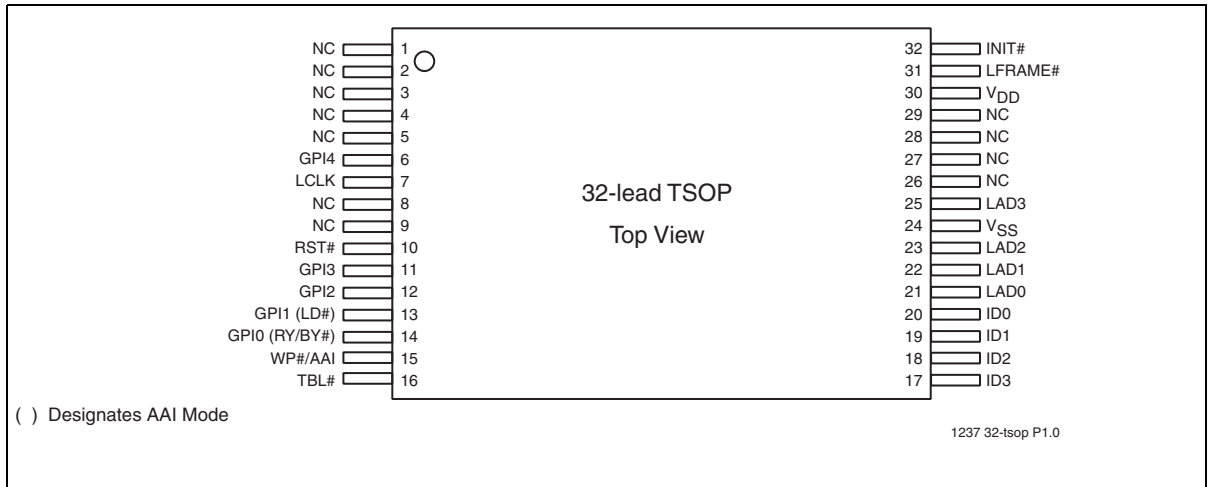

Figure 4: Pin Assignments for 32-lead TSOP

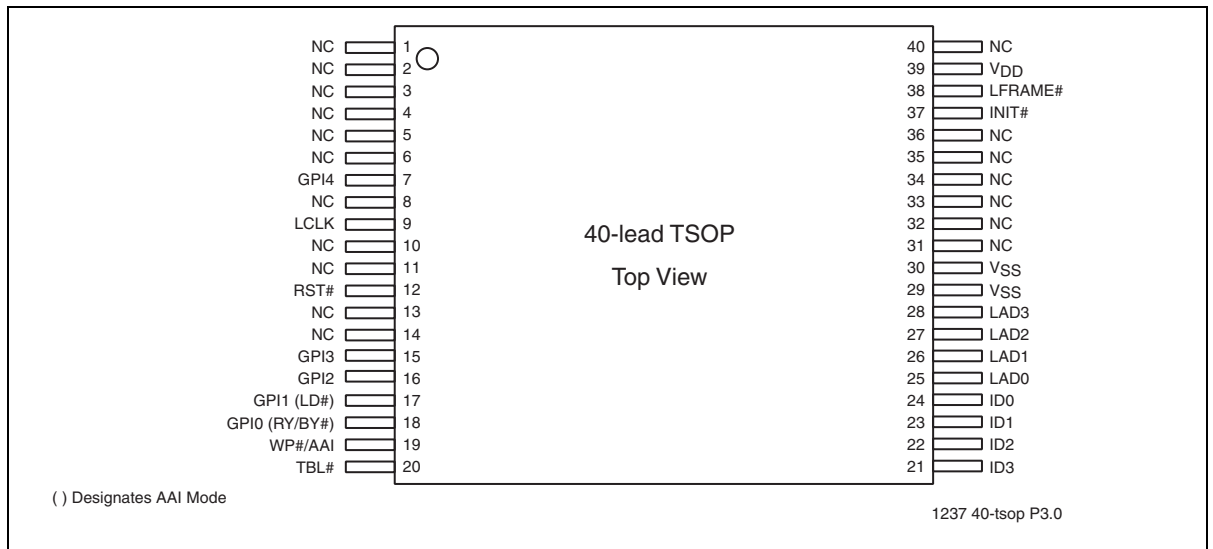

Figure 5: Pin Assignments for 40-lead TSOP

Pin Descriptions

Table 1: Pin Description

| Symbol | Pin Name | Type ¹ | Interface | | Functions |
|-----------------|------------------------|-------------------|-----------|-----|---|
| | | | AAI | LPC | |
| LCLK | Clock | I | X | X | To accept a clock input from the control unit |
| LAD[3:0] | Address and Data | I/O | X | X | To provide LPC bus information, such as addresses and command Inputs/Outputs data. |
| LFRAME # | Frame | I | X | X | To indicate the start of a data transfer operation; also used to abort an LPC cycle in progress. |
| RST# | Reset | I | X | X | To reset the operation of the device |
| INIT# | Initialize | I | X | X | This is the second reset pin for in-system use. This pin is internally combined with the RST# pin. If this pin or RST# pin is driven low, identical operation is exhibited. |
| ID[3:0] | Identification Inputs | I | X | X | These four pins are part of the mechanism that allows multiple parts to be attached to the same bus. The strapping of these pins is used to identify the component. The boot device must have ID[3:0]=0000, all subsequent devices should use sequential up-count strapping. These pins are internally pulled-down with a resistor between 20-100 K Ω . When in AAI mode, these pins operate identically as in Firmware Memory cycles. |
| GPI[4:0] | General Purpose Inputs | I | | X | These individual inputs can be used for additional board flexibility. The state of these pins can be read through LPC registers. These inputs should be at their desired state before the start of the LPC clock cycle during which the read is attempted, and should remain in place until the end of the Read cycle. Unused GPI pins must not be floated. GPI[2:4] are ignored when in AAI mode. |
| TBL# | Top Block Lock | I | | X | When low, prevents programming to the boot block sectors at top of device memory. When TBL# is high it disables hardware write protection for the top block sectors. This pin cannot be left unconnected. TBL# setting is ignored when in AAI mode. |
| WP#/AAI | Write Protect | I | | X | When low, prevents programming to all but the highest addressable block (Boot Block). When WP# is high it disables hardware write protection for these blocks. This pin cannot be left unconnected. |
| WP#/AAI | AAI Enable | I | X | | When set to the Supervoltage $V_H = 9V$, configures the device to program multiple bytes in AAI mode. When brought to V_{IL}/V_{IH} , returns device to LPC mode. |
| RY/BY# | Ready/Busy# | O | X | | Open drain output that indicates the device is ready to accept data in an AAI mode, or that the internal cycle is complete. Used in conjunction with LD# pin to switch between these two flag states. |
| LD# | Load-Enable# | I | X | | Input pin which when low, indicates the host is loading data in an AAI programming cycle. If LD# is high, the host signals the AAI interface that it is terminating a command. LD# low/high switches the RY/BY# output from a "buffer free" flag to a "programming complete" flag. |
| V _{DD} | Power Supply | PWR | X | X | To provide power supply (3.0-3.6V) |
| V _{SS} | Ground | PWR | X | X | Circuit ground (0V reference) |
| NC | No Connection | | N/A | N/A | Unconnected pins. |

1. I=Input, O=Output

T1.2 20005029

Clock

The LCLK pin accepts a clock input from the host controller.

Input/Output Communications

The LAD[3:0] pins are used to serially communicate cycle information such as cycle type, cycle direction, ID selection, address, data, and sync fields.

Input Communication Frame

The LFRAME# pin is used to indicate start of a LPC bus cycle. The pin is also used to abort an LPC bus cycle in progress.

Reset

A V_{IL} on INIT# or RST# pin initiates a device reset. INIT# and RST# pins have the same function internally. It is required to drive INIT# or RST# pins low during a system reset to ensure proper CPU initialization. During a Read operation, driving INIT# or RST# pins low deselects the device and places the output drivers, LAD[3:0], in a high impedance state. The reset signal must be held low for a minimum of time T_{RSTP} . A reset latency occurs if a reset procedure is performed during a Program or Erase operation. See Table 27, Reset Timing Parameters, for more information. A device reset during an active Program or Erase operation will abort the operation and memory contents may become invalid due to data being altered or corrupted from an incomplete Erase or Program operation.

Identification Inputs

These pins are part of a mechanism that allows multiple devices to be attached to the same bus. The strapping of these pins is used to identify the component. The boot device must have ID[3:0] = 0; all subsequent devices should use sequential count-up strapping. These pins are internally pulled-down with a resistor between 20-100 K Ω .

General Purpose Inputs

The General Purpose Inputs (GPI[4:0]) can be used as digital inputs for the CPU to read. The GPI register holds the values on these pins. The data on the GPI pins must be stable before the start of a GPI register Read and remain stable until the Read cycle is complete. The pins must be driven low, V_{IL} , or high, V_{IH} but not left unconnected (float).

Write Protect / Top Block Lock

The Top Boot Lock (TBL#) and Write Protect (WP#/AAI) pins are provided for hardware write protection of device memory in the SST49LF016C. The TBL# pin is used to write protect 16 KByte at the highest memory address range for the SST49LF016C. WP#/AAI pin write protects the remaining sectors in the flash memory. An active low signal at the TBL# pin prevents Program and Erase operations of the top Boot Block. When TBL# pin is held high, write protection of the top Boot Block is then determined by the Boot Block Locking registers. The WP#/AAI pin serves the same function for the remaining sectors of the device memory. The TBL# and WP#/AAI pins write protection functions operate independently of one another. Both TBL# and WP#/AAI pins must be set to their required protection states prior to starting a Program or Erase operation. A logic level change occurring at the TBL# or WP#/AAI pin during a Program or Erase operation could cause unpredictable results. TBL# and WP#/AAI pins cannot be left unconnected.

TBL# is internally OR'ed with the top Boot Block Locking register. When TBL# is low, the top Boot Block is hardware write protected regardless of the state of the Write-Lock bit for the Boot Block Locking register. Clearing the Write-Protect bit in the register when TBL# is low will have no functional effect, even though the register may indicate that the block is no longer locked.

WP#/AAI is internally OR'ed with the Block Locking register. When WP#/AAI is low, the blocks are hardware write protected regardless of the state of the Write-Lock bit for the corresponding Block Locking registers. Clearing the Write-Protect bit in any register when WP#/AAI is low will have no functional effect, even though the register may indicate that the block is no longer locked.

AAI Enable

The AAI Enable pin (WP#/AAI) is used to enable the Auto Address Increment (AAI) mode. When the WP#/AAI pin is set to the Supervoltage V_H ($9\pm 0.5V$), the device is in AAI mode with Multi-Byte programming. When the WP#/AAI pin is brought to V_{IL}/V_{IH} levels, the device returns to LPC mode.

Ready/Busy

The Ready/Busy pin (RY/BY#), is an open drain output which indicates the device is ready to accept data in an AAI mode, or that the internal programming cycle is complete. The pin is used in conjunction with the LD# pin to switch between these two flag states (see Table 18).

Load Enable

The Load Enable pin (LD#), is an input pin which when low, indicates the host is loading data in an AAI programming cycle. Data is loaded in the SST49LF016C at the rising edge of the clock. If LD# is high, it signals the AAI interface that the host is terminating the command. LD# low/high switches the RY/BY# output from buffer free flag to programming complete flag (see Table 18).

No Connection (NC)

These pins are not connected internally.

Design Considerations

SST recommends a high frequency 0.1 μF ceramic capacitor to be placed as close as possible between V_{DD} and V_{SS} less than 1 cm away from the V_{DD} pin of the device. Additionally, a low frequency 4.7 μF electrolytic capacitor from V_{DD} to V_{SS} should be placed within 1 cm of the V_{DD} pin. If you use a socket for programming purposes add an additional 1-10 μF next to each socket. The $\text{RST}\#$ pin must remain stable at V_{IH} for the entire duration of an Erase operation. $\text{WP}\#/\text{AAI}$ must remain stable at V_{IH} for the entire duration of the Erase and Program operations for non-Boot Block sectors. To write data to the top Boot Block sectors, the $\text{TBL}\#$ pin must also remain stable at V_{IH} for the entire duration of the Erase and Program operations.

Mode Selection

The SST49LF016C flash memory device operates in two distinct interface modes: the LPC mode and the Auto Address Increment (AAI) mode. The $\text{WP}\#/\text{AAI}$ pin is used to set the interface mode selection. The device is in AAI mode when the $\text{WP}\#/\text{AAI}$ pin is set to the Supervoltage V_{H} ($9\pm 0.5\text{V}$), and in the LPC mode when the $\text{WP}\#/\text{AAI}$ is set to $V_{\text{IL}}/V_{\text{IH}}$. The mode selection must be configured prior to device operation.

LPC Mode

Device Operation

The SST49LF016C supports Multi-Byte Firmware Memory Read and Write cycle types as defined in Low Pin Count Interface Specification, Revision 1.1. Table 2 shows the size of transfer supported by the SST49LF016C.

Table 2: Transfer Size Supported

| Cycle Type | Size of Transfer |
|-----------------------|------------------------|
| Firmware Memory Read | 1, 2, 4, 16, 128 Bytes |
| Firmware Memory Write | 1, 2, 4 Bytes |

T2.1 20005029

The LPC mode uses a 5-signal communication interface: one control line, LFRAME#, which is driven by the host to start or abort a bus cycle, a 4-bit data bus, LAD[3:0], used to communicate cycle type, cycle direction, ID selection, address, data and sync fields. The device enters standby mode when LFRAME# is taken high and no internal operation is in progress.

The host drives LFRAME# signal from low-to-high to capture the start field of a LPC cycle. On the cycle in which LFRAME# goes inactive, the last latched value is taken as the START value. The START value determines whether the SST49LF016C will respond to a Firmware Memory Read/Write cycle type as defined in Table 3.

Table 3: Firmware Memory Cycles START Field Definition

| START Value | Definition |
|-------------|--|
| 1101 | Start of a Firmware Memory Read cycle |
| 1110 | Start of a Firmware Memory Write cycle |

T3.1 20005029

See following sections on details of Firmware Memory cycle types (Tables 4 and 5). Two-cycle Program and Erase command sequences are used to initiate Firmware Memory Program and Erase operations. See Table 8 for a listing of Program and Erase commands.

Firmware Memory Cycles

Firmware Memory Read Cycle

Table 4: Firmware Memory Read Cycle Field Definitions

| Clock Cycle | Field Name | Field Contents LAD[3:0] ¹ | LAD[3:0] Direction | Comments |
|-------------|------------|--------------------------------------|--------------------|--|
| 1 | START | 1101 | IN | LFRAME# must be active (low) for the part to respond. Only the last start field (before LFRAME# transitions high) will be recognized. The START field contents (1101b) indicate a Firmware Memory Read cycle. |
| 2 | IDSEL | 0000 to 1111 | IN | Indicates which SST49LF016C device should respond. If the IDSEL (ID select) field matches the value of ID[3:0], then that particular device will respond to the LPC bus cycle. |
| 3-9 | MADDR | YYYY | IN | These seven clock cycles make up the 28-bit memory address. YYYY is one nibble of the entire address. Addresses are transferred most-significant nibble first. |
| 10 | MSIZE | KKKK | IN | The MSIZE field indicates how many bytes will be transferred during multi-byte operations. Device will execute multi-byte read of 2^{MSIZE} bytes. SST49LF016C supports only MSIZE = 0, 1, 2, 4, 7 (1, 2, 4, 16, 128 Bytes), with KKKK=0000b, 0001b, 0010b, 0100b, or 0111b. |
| 11 | TAR0 | 1111 | IN, then Float | In this clock cycle, the master has driven the bus to all '1's and then floats the bus, prior to the next clock cycle. This is the first part of the bus "turnaround cycle." |
| 12 | TAR1 | 1111 (float) | Float, then OUT | The SST49LF016C takes control of the bus during this cycle. |
| 13 | RSYNC | 0000 (READY) | OUT | During this clock cycle, the device generates a "ready sync" (RSYNC) indicating that the device has received the input data. The least-significant nibble of the least-significant byte will be available during the next clock cycle. |
| 14-A | DATA | ZZZZ | OUT | $A=(13+2^{n+1})$; $n = MSIZE$. Least significant nibbles outputs first. |
| (A+1) | TAR0 | 1111 | OUT, then Float | In this clock cycle, the SST49LF016C drives the bus to all ones and then floats the bus prior to the next clock cycle. This is the first part of the bus "turnaround cycle." $A=(13+2^{n+1})$; $n = MSIZE$ |
| (A+2) | TAR1 | 1111 (float) | Float, then IN | The host resumes control of the bus during this cycle. $A=(13+2^{n+1})$; $n = MSIZE$ |

T4.0 20005029

1. Field contents are valid on the rising edge of the present clock cycle.

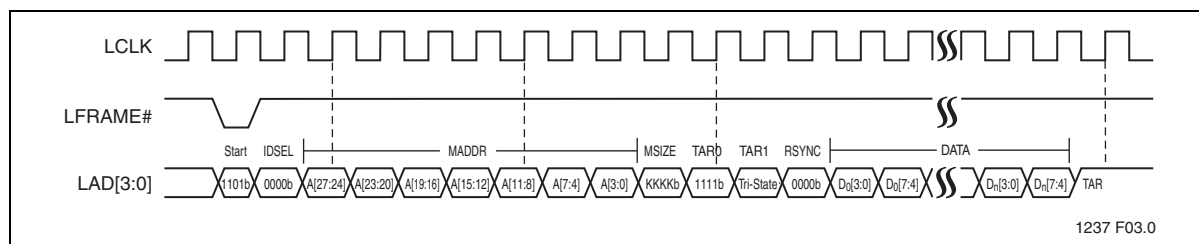

1237 F03.0

Figure 6: Firmware Memory Read Cycle Waveform

Firmware Memory Write Cycle

Table 5: Firmware Memory Write Cycle

| Clock Cycle | Field Name | Field Contents LAD[3:0] ¹ | LAD[3:0] Direction | Comments |
|-------------|------------|--------------------------------------|--------------------|--|
| 1 | START | 1110 | IN | LFRAME# must be active (low) for the part to respond. Only the last start field (before LFRAME# transitions high) will be recognized. The START field contents (1110b) indicate a Firmware Memory Write cycle. |
| 2 | IDSEL | 0000 to 1111 | IN | Indicates which SST49LF016C device should respond. If the IDSEL (ID select) field matches the value of ID[3:0], then that particular device will respond to the whole bus cycle. |
| 3-9 | MADDR | YYYY | IN | These seven clock cycles make up the 28-bit memory address. YYYY is one nibble of the entire address. Addresses are transferred most-significant nibble first. |
| 10 | MSIZE | KKKK | IN | The MSIZE field indicates how many bytes will be transferred during multi-byte operations. Device supports 1, 2, and 4 Bytes write with MSIZE = 0, 1, or 2, and KKKK=0000b, 0001b, or 0010b. |
| 11-A | DATA | ZZZZ | IN | $A=(10+2^{n+1})$; n = MSIZE Least significant nibble entered first. |
| (A+1) | TAR0 | 1111 | IN then Float | In this clock cycle, the master has driven the bus to all '1's and then floats the bus prior to the next clock cycle. This is the first part of the bus "turnaround cycle." $A=(10+2^{n+1})$; n = MSIZE |
| (A+2) | TAR1 | 1111 (float) | Float then OUT | The SST49LF016C takes control of the bus during this cycle. $A=(10+2^{n+1})$; n = MSIZE |
| (A+3) | RSYNC | 0000 | OUT | During this clock cycle, the SST49LF016C generates a "ready sync" (RSYNC) and outputs the values 0000, indicating that it has received data or a flash command. $A=(10+2^{n+1})$; n = MSIZE |
| (A+4) | TAR0 | 1111 | OUT then Float | In this clock cycle, the SST49LF016C drives the bus to all '1's and then floats the bus prior to the next clock cycle. This is the first part of the bus "turnaround cycle". $A=(10+2^{n+1})$; n = MSIZE |
| (A+5) | TAR1 | 1111 (float) | Float then IN | The host resumes control of the bus during this cycle. $A=(10+2^{n+1})$; n = MSIZE |

T5.0 20005029

1. Field contents are valid on the rising edge of the present clock cycle.

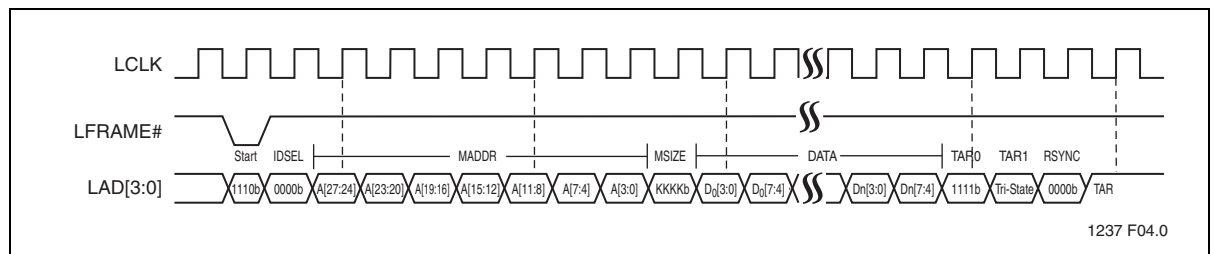

Figure 7: Firmware Memory Write Cycle Waveform

Abort Mechanism

If LFRAME# is driven low for one or more clock cycles after the start of a bus cycle, the cycle will be terminated. The host may drive the LAD[3:0] with '1111b' (ABORT nibble) to return the interface to ready mode. The ABORT only affects the current bus cycle. For a multi-cycle command sequence, such as the Erase or Program commands, ABORT doesn't interrupt the entire command sequence, only the current bus cycle of the command sequence. The host can re-send the bus cycle for the aborted command and continue the command sequence after the device is ready again.

Response to Invalid Fields for Firmware Memory Cycle

During an on-going Firmware Memory bus cycle, the SST49LF016C will not explicitly indicate that it has received invalid field sequences. The response to specific invalid fields or sequences is described as follows:

ID mismatch:

If the IDSEL field does not match ID[3:0], the device will ignore the cycle. See "Multiple Device Selection for Firmware Memory Cycle" on page 15 for details.

Address out of range:

The address sequence is 7 fields long (28 bits) with Firmware Memory bus cycles. Only some of the address fields bits are decoded by the SST49LF016C. These are: A₀ through A₂₀ and A₂₂. Address A₂₂ has the special function of directing reads and writes to the flash core (A₂₂=1) or to the register space (A₂₂=0).

Invalid MSIZE field:

If the SST49LF016C receives an invalid size field during a Firmware Memory Read or Write operation, the device will reset and no operation will be attempted. The device will not generate any kind of response in this situation. The SST49LF016C will only respond to values listed in Table 6.

Table 6: Valid MSIZE field Values for Firmware Memory Cycles

| MSIZE | Direction | Size of Transfer |
|-------|-----------|------------------|
| 0000 | R/W | 1 Byte |
| 0001 | R/W | 2 Byte |
| 0010 | R/W | 4 Byte |
| 0100 | R | 16 Byte |
| 0111 | R | 128 Byte |

T6.0 20005029

Once valid START, IDSEL, and MSIZE are received, the SST49LF016C will always complete the bus cycle. However, if the device is busy performing a flash Erase or Program operation, no new internal memory Write will be executed. As long as the states of LAD[3:0] and LFRAME# are known, the response of the ST49LF016C to signals received during the cycle is predictable.

Non-boundary-aligned address:

The SST49LF016C accepts multi-byte transfers for both Read and Write operations. The device address space is divided into uniform page sizes 2, 4, 16, or 128 bytes wide, according to the MSIZE value (see Table 6). The host issues only one address in the MADDR field of the Firmware Memory Cycle, but multiple bytes are read from or written to the device. For this reason the MADDR address should be page boundary-aligned. This means the address should be aligned to a Word boundary ($A_0 = 0$) for a 2-byte transfer, a double Word boundary (e.g. $A_0 = 0, A_1 = 0$) for a 4-byte transfer, and so on. If the address supplied by the host is not page boundary-aligned, the SST49LF016C will force a boundary alignment, starting the multi-byte Read or Write operation from the lower byte of the addressed page.

Multiple Device Selection

Multiple LPC serial flash devices may be strapped to increase memory densities in a system. The four ID pins, ID[3:0], allow up to 16 devices to be attached to the same bus by using different ID strapping in a system. BIOS support, bus loading, or the attaching bridge may limit this number. The boot device must have an ID of 0000b (determined by ID[3:0]); subsequent devices use incremental numbering. Equal density must be used with multiple devices.

Multiple Device Selection for Firmware Memory Cycle

For Firmware Memory Read/Write cycles, hardware strapping values on ID[3:0] must match the values in IDSEL field. The SST49LF016C will compare these bits with ID[3:0]'s strapping values. If there is a mismatch, the device will ignore the remainder of the cycle. See Table 7 for Multiple Device Selection Configuration.

Table 7: Firmware Memory Multiple Device Selection Configuration

| Device # | ID[3:0] | IDSEL |
|-----------------|---------|-------|
| 0 (Boot device) | 0000 | 0000 |
| 1 | 0001 | 0001 |
| 2 | 0010 | 0010 |
| 3 | 0011 | 0011 |
| 4 | 0100 | 0100 |
| 5 | 0101 | 0101 |
| 6 | 0110 | 0110 |
| 7 | 0111 | 0111 |
| 8 | 1000 | 1000 |
| 9 | 1001 | 1001 |
| 10 | 1010 | 1010 |
| 11 | 1011 | 1011 |
| 12 | 1100 | 1100 |
| 13 | 1101 | 1101 |
| 14 | 1110 | 1110 |
| 15 | 1111 | 1111 |

T7.0 20005029

Device Commands

Device operation is controlled by commands written to the Command User Interface (CUI). Execution of a specific command is handled by internal functions after a CUI receives and processes the command. After power-up or a Reset operation the device enters Read mode. Commands consist of one or two sequential Bus-Write operations. The commands are summarized in Table 8, “Software Command Sequence”.

Table 8: Software Command Sequence

| Command | Bus Cycles Required | First Bus Cycle | | | Second Bus Cycle | | |
|--|---------------------|-----------------|-------------------|------------------|------------------|-------------------|------------------|
| | | Oper | Addr ¹ | Data | Oper | Addr ¹ | Data |
| Read-Array/Reset | 1 | Write | X | FFH | | | |
| Read-Software-ID ² / Read-Security-ID ³ | ≥ 2 | Write | X | 90H | Read | IA ⁴ | ID ⁵ |
| Read-Status-Register ³ | 2 | Write | X | 70H | Read | X | SRD ⁶ |
| Clear-Status-Register | 1 | Write | X | 50H | | | |
| Sector-Erase ⁷ | 2 | Write | X | 30H | Write | SAx ⁸ | D0H |
| Block-Erase ⁷ | 2 | Write | X | 20H | Write | BAx | D0H |
| Program ^{7,9} | 2 | Write | X | 40H or 10H | Write | WA ¹⁰ | WD ¹¹ |
| Program-/Erase-Suspend | 1 | Write | X | B0H | | | |
| Program-/Erase-Resume | 1 | Write | X | D0H | | | |
| User-Security-ID-Program ¹² | 2 | Write | X | A5H | Write | WA ¹⁰ | Data |
| User-Security-ID-Program-Lockout | 2 | Write | X | 85H | Write | X | 00H |

T8.0 20005029

1. This value must be a valid address within the device Memory Address Space. X can be V_{IH} or V_{IL}, but no other value.
2. SST Manufacturer's ID = BFH, is read with A₂₀-A₀ = 0.
SST49LF016C Device ID = 5CH, is read with A₂₀-A₁ = 0, A₀ = 1.
Following the Read-Software-ID/Read-Security-ID command,
Read operations access Manufacturer's ID and Device ID or Security ID.
3. Following the Read-Software-ID/Read-Security-ID command, Read operations access manufacturer's ID and Device ID or Security ID. Read-Software-ID/Read-Security-ID and Read-Status-Register will return register data until another valid command is written.
4. IA = Device Identification Address/Security ID Address.
5. ID = Data read from identifier codes/Data read from Security ID
6. SRD = Data read from Status register
7. The sector or block must not be write-locked when attempting Erase or Program operations.
Attempts to issue an Erase or Program command to a write-locked sector/block will fail.
8. SA_x for Sector-Erase Address
BA_x for Block-Erase Address
9. The Program command operates on multiple bytes.
10. WA = Address of memory location to be written
11. WD = Data to be written at location WA
12. Valid addresses for the User Security ID space are from FFFC 0188H to FFFC 019FH.

Read-Array Command

Upon initial device power-up and after exit from reset, the device defaults to the read array mode. This operation can also be initiated by writing the Read-Array command. (See Table 8.) The device remains available for array reads until another command is written. Once an internal Program/Erase operation starts, the device will not recognize the Read-Array command until the operation is completed, unless the operation is suspended via a Program/Erase Suspend command.

Read-Software-ID Command

The Read-Software-ID operation is initiated by writing the Read-Software-ID command. Following the command, the device will output the manufacturer's ID and device ID from the addresses shown in Table 9. Any other valid command will terminate the Read-Software-ID operation.

The Read-Software-ID command is the same as the Read-Security-ID command. See "Security ID Commands" on page 19.

Table 9: Product Identification

| | Address¹ | Data |
|--------------------------|----------------------------|-------------|
| Manufacturer's ID | FFFC 0000H | BFH |
| Device ID SST49LF016C | FFFC 0001H | 5CH |

T9.1 20005029

1. Address shown in this column is for boot device only. Address locations should appear elsewhere in the 4 GByte system memory map depending on ID strapping values on ID[3:0] pins when multiple LPC memory devices are used in a system.

Read-Status-Register Command

The Status register may be read to determine when a Sector-/Block-Erase or Program completes, and whether the operation completed successfully. The Status register may be read at any time by writing the Read-Status-Register command. After writing this command, all subsequent Read operations will return data from the Status register until another valid command is written.

The default value of the Status register after device power-up or reset is 80H.

Clear-Status-Register Command

The user can reset the Status register's Block Protect Status (BPS) bit to 0 by issuing a Clear-Status-Register command. Device power-up and hardware reset will also reset BPS to 0.

Table 10: Software Status Register

| Bit | Name | Function |
|-----|------|--|
| 0 | RES | Reserved for future use |
| 1 | BPS | Block Protect Status The Block Write-Lock bit should be interrogated only after Erase or Program command is issued. It informs the system whether or not the selected block is locked. BPS does not provide a continuous indication of Write-Lock bit value. 0: Block Unlocked 1: Operation Aborted, Block Write-Lock bit set. |
| 2:5 | RES | Reserved for future use |
| 6 | ESS | Erase Suspend Status 0: Erase in progress/completed 1: Erase suspended |
| 7 | WSMS | Write State Machine Status Check WSMS to determine erase or program completion. 0: Busy 1: Ready |

T10.0 20005029

Sector-/Block-Erase Command

The Erase Command operates on one sector or block at a time. This command requires an (arbitrary) address within the sector or block to be erased. Note that a Sector/Block Erase operation changes all Sector/Block byte data to FFh. If a Read operation is performed after issuing the erase command, the device will automatically output Status Register data. The system can poll the Status Register in order to verify the completion of the Sector/Block Erase operation (please refer to Table 10, Status Register Definition). If a Sector/Block Erase is attempted on a locked block, the operation will fail and the data in the Sector/Block will not be changed. In this case, the Status Register will report the error (BPS=1).

Program Command

The Program command operates on multiple bytes (Refer to Table 5). This command specifies the address and data to be programmed. During the Program operation the device automatically outputs the Status Register data when read. The system can poll the Status Register in order to verify the completion of the Program operation (refer to Table 10, "Software Status Register"). If a Program operation is attempted on a locked block, the operation will fail and the data in the addressed byte will not be changed. In this case, the Status Register will report the error (BPS=1).

Program-/Erase-Suspend or Program-/Erase-Resume Operations

The Program-Suspend and Erase-Suspend operations share the same software command sequence (B0H). The Program-Resume and Erase-Resume operations share the same software command sequence (D0H). See Table 8, "Software Command Sequence" on page 16.

Erase-Suspend/Erase-Resume Commands

The Erase Suspend command allows Sector-Erase or Block-Erase interruption in order to read or program data in another block of memory. Once the Erase-Suspend command is executed, the device will suspend any on-going Erase operation within time T_{ES} (10 μ s). The device outputs status register data when read after the Erase-Suspend command is written. The system is able to determine when the Erase operation has been completed ($WSMS=1$) by polling the status register. After an Erase-Suspend, the device will set the status register ESS bit ($ESS=1$) if the Erase has been successfully suspended (refer to Table 10, "Software Status Register"). The Erase-Resume command resumes the Erase operation that had been previously suspended.

After a successful Erase-Suspend, a Read-Array command may be written to read data from a Sector/Block other than the suspended Sector/Block. A Program command sequence may also be issued during Erase Suspend to program data in memory locations other than the Sector/Block currently in the Erase-Suspend mode. If a Read-Array command is written to an address within the suspended Sector/Block this may result in reading invalid data. If a Program command is written to an address within the suspended Sector/Block the command is acknowledged but rejected. Other valid commands while erase is suspended include Read-Status-Register, Read-Device-ID, and Erase-Resume.

The Erase-Resume command resumes the Erase process in the suspended sector or block. After the Erase-Resume command is written, the device will continue the Erase process. Erase cannot resume until any Program operation initiated during Erase-Suspend has completed. Suspended operations cannot be nested: the system needs to complete or resume any previously suspended operation before a new operation can be suspended. See Figure 8 for flowchart.

Program-Suspend/Program-Resume Command

The Program-Suspend and Program-Resume commands have no influence on the device. Since the device requires a maximum of T_{BP} (10 μ s) in order to program a byte (see Table 28), when a Program-Suspend command is written, the suspended Byte Program operation will always be successfully completed within the suspend latency time ($T_{ES} = T_{BP} = 10 \mu$ s).

Security ID Commands

The SST49LF016C device offers a 256-bit Security ID space. The Security ID space is divided into two parts. One 64-bit segment is programmed at SST with a unique 64-bit number: this number cannot be changed by the user. The other segment is 192-bit wide and is left blank: this space is available for customers and can be programmed as desired.

The User-Security-ID-Program command is shown in Table 8, "Software Command Sequence". Use the memory addresses specified in Table 11 for Security ID programming. Once the customer segment is programmed, it can be locked to prevent any alteration. The User-Security-ID-Program-Lockout command is shown in Table 8, "Software Command Sequence".

In order to read the Security ID information, the user can issue a Read Security ID Command (90H) to the device. At this point the device enters the Read-Software-ID/Read-Security-ID mode. The Security ID information can be read at the memory addresses in Table 11.

A Read-Array/Reset command (FFH) must then be issued to the device in order to exit the Read-Software-ID/Read-Security-ID mode and return to Read-Array mode.

An alternate method to read the Security ID information is to read the Security ID registers located into the register space as described in the "Security ID Registers" section.

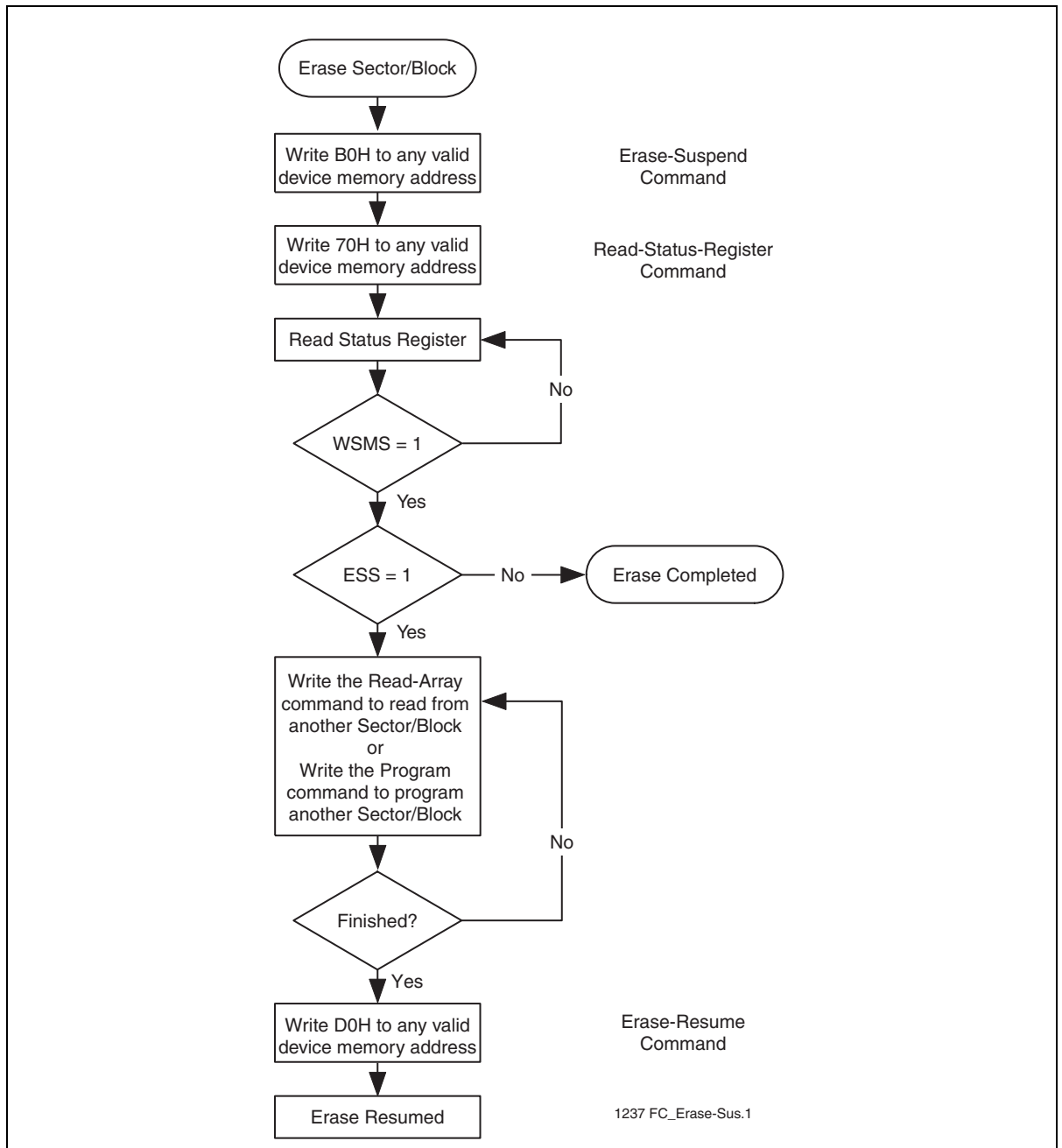

Figure 8: Erase-Suspend Flow Chart

Table 11: Security ID Addresses

| Address Range | Security ID Segment | Size |
|------------------------|---------------------|--------------------|
| FFFC 0180 to FFFC 0187 | Factory-Programmed | 8 bytes – 64 bit |
| FFFC 0188 to FFFC 019F | User-Programmed | 24 bytes – 192 bit |

T11.0 20005029

Registers

There are five types of registers available on the SST49LF016C, the multi-byte Read/Write configuration registers (for Firmware Memory cycle), General Purpose Inputs registers, Block Locking registers, Security ID register, and the JEDEC ID registers. These registers appear at their respective address location in the 4 GByte system memory map. Unused register locations will read as 00H. Any attempt to read or write any register during an internal Write operation will be ignored.

Read or write access to the register during an internal Program/Erase operation will be completed as follows:

- Multi-byte Read/Write Configuration registers, General Purpose Inputs register, and Block Locking registers can be accessed normally
- Security ID register and the JEDEC ID registers can not be accessed (reading these registers will return unused register data 00H).

Multi-Byte Read/Write Configuration Registers (Firmware Memory Cycle)

The multi-byte read/write configuration (MBR) registers are four 8-bit read-only registers located at addresses FFBC0005-FFBC0008 for boot configured device (see Table 13). These registers are accessible using Firmware Memory Read cycle only. These registers contain information about multi-byte read and write access sizes that will be accepted for Firmware Memory multi-byte Read commands. The registers are not available in AAI mode.

In case of multi-byte Firmware Memory register reads, the device will return register data for the addressed register until the command finishes, or is aborted.

General Purpose Inputs Register

The General Purpose Inputs register (GPI_REG) passes the state of GPI[4:0] pins on the SST49LF016C. It is recommended that the GPI[4:0] pins be in the desired state before LFRAME# is brought low for the beginning of the bus cycle, and remain in that state until the end of the cycle. There is no default value since this is a pass-through register. The GPI_REG register for the boot device appears at FFBC0100H in the 4 GByte system memory map, and will appear elsewhere if the device is not the boot device (see Table 12). This register is not available to be read when the device is in an Erase/Program operation. In case of multi-byte Firmware Memory cycle register reads, the device will return register data for the addressed register until the command finishes, or is aborted.

Table 12: General Purpose Register

| Register | Register Address ¹ | Default Value | Access |
|----------|-------------------------------|---------------|--------|
| GPI_REG | FFBC 0100H | N/A | R |

T12.0 20005029
1. Address shown in this column is for boot device only. Address locations should appear elsewhere in the 4 GByte system memory map depending on ID strapping values on ID[3:0] pins when multiple LPC memory devices are used in a system.

Table 13: Multi-byte Read/Write Configuration Registers (Firmware Memory Cycle Only)

| Register | Register Address ¹ | Data | Access | Description |
|--------------------|-------------------------------|------------|--------|---|
| MULTI_BYTE_READ_L | FFBC 0005H | 0100 1011b | R | Device supports 1,2,4, 16, 128 Byte reads |
| MULTI_BYTE_READ_H | FFBC 0006H | 0000 0000b | R | Future Expansion for Read |
| MULTI_BYTE_WRITE_L | FFBC 0007H | 0000 0011b | R | Device supports 1, 2, 4 Byte Write |
| MULTI_BYTE_WRITE_H | FFBC 0008H | 0000 0000b | R | Future Expansion for Write |

- T13.0 20005029
1. Address shown in this column is for boot device only. Address locations should appear elsewhere in the 4 GByte system memory map depending on ID strapping values on ID[3:0] pins when multiple LPC memory devices are used in a system.

Block Locking Registers

SST49LF016C provides software controlled lock protection through a set of Block Locking registers. The Block Locking Registers are read/write registers and they are accessible through standard addressable memory locations specified in Table 14. Unused register locations will return 00H if read.

In case of multi-byte register reads with Firmware Memory cycle, the device will return register data for the addressed register until the command finishes, or is aborted.

Table 14: Block Locking Registers

| Register | Block Size | SST49LF016C Protected Memory Address ¹ Range | Memory Map Register Address ¹ |
|--------------|------------|---|--|
| T_BLOCK_LK | 16K | 1FFFFFFH-1FC000H | FFBFC002H |
| T_MINUS01_LK | 8K | 1BFFFFFFH-1FA000H | FFBFA002H |
| T_MINUS02_LK | 8K | 1F9FFFFFFH-1F8000H | FFBF8002H |
| T_MINUS03_LK | 32K | 1F7FFFFFFH-1F0000H | FFBF0002H |
| T_MINUS04_LK | 64K | 1EFFFFFFH-1E0000H | FFBE0002H |
| T_MINUS05_LK | 64K | 1DFFFFFFH-1D0000H | FFBD0002H |
| T_MINUS06_LK | 64K | 1CFFFFFFH-1C0000H | FFBC0002H |
| T_MINUS07_LK | 64K | 1BFFFFFFH-1B0000H | FFBB0002H |
| T_MINUS08_LK | 64K | 1AFFFFFFH-1A0000H | FFBA0002H |
| T_MINUS09_LK | 64K | 19FFFFFFH-190000H | FFB90002H |
| T_MINUS10_LK | 64K | 18FFFFFFH-180000H | FFB80002H |
| T_MINUS11_LK | 64K | 17FFFFFFH-170000H | FFB70002H |
| T_MINUS12_LK | 64K | 16FFFFFFH-160000H | FFB60002H |
| T_MINUS13_LK | 64K | 15FFFFFFH-150000H | FFB50002H |
| T_MINUS14_LK | 64K | 14FFFFFFH-140000H | FFB40002H |
| T_MINUS15_LK | 64K | 13FFFFFFH-130000H | FFB30002H |
| T_MINUS16_LK | 64K | 12FFFFFFH-120000H | FFB20002H |
| T_MINUS17_LK | 64K | 11FFFFFFH-110000H | FFB10002H |
| T_MINUS18_LK | 64K | 10FFFFFFH-100000H | FFB00002H |
| T_MINUS19_LK | 64K | 0FFFFFFFH-0F0000H | FFAF0002H |
| T_MINUS20_LK | 64K | 0EFFFFFFH-0E0000H | FFAE0002H |
| T_MINUS21_LK | 64K | 0DFFFFFFH-0D0000H | FFAD0002H |
| T_MINUS22_LK | 64K | 0CFFFFFFH-0C0000H | FFAC0002H |
| T_MINUS23_LK | 64K | 0BFFFFFFH-0B0000H | FFAB0002H |
| T_MINUS24_LK | 64K | 0AFFFFFFH-0A0000H | FFAA0002H |
| T_MINUS25_LK | 64K | 09FFFFFFH-090000H | FFA90002H |
| T_MINUS26_LK | 64K | 08FFFFFFH-080000H | FFA80002H |
| T_MINUS27_LK | 64K | 07FFFFFFH-070000H | FFA70002H |
| T_MINUS28_LK | 64K | 06FFFFFFH-060000H | FFA60002H |
| T_MINUS29_LK | 64K | 05FFFFFFH-050000H | FFA50002H |
| T_MINUS30_LK | 64K | 04FFFFFFH-040000H | FFA40002H |
| T_MINUS31_LK | 64K | 03FFFFFFH-030000H | FFA30002H |
| T_MINUS32_LK | 64K | 02FFFFFFH-020000H | FFA20002H |
| T_MINUS33_LK | 64K | 01FFFFFFH-010000H | FFA10002H |
| T_MINUS34_LK | 64K | 00FFFFFFH-000000H | FFA00002H |

T14.0 20005029

1. Address shown in this column is for boot device only. Address locations should appear elsewhere in the 4 GByte system memory map depending on ID strapping values on ID[3:0] pins when multiple LPC memory devices are used in a system.

Table 15: Block Locking Register Bits

| Reserved Bit [7:3] | Read-Lock Bit [2] | Lock-Down Bit [1] | Write-Lock Bit [0] | Lock Status |
|--------------------|-------------------|-------------------|--------------------|--|
| 00000 | 0 | 0 | 0 | Full Access |
| 00000 | 0 | 0 | 1 | Write Locked (Default State at Power-Up) |
| 00000 | 0 | 1 | 0 | Locked Open (Full Access Locked Down) |
| 00000 | 0 | 1 | 1 | Write Locked Down |
| 00000 | 1 | 0 | 0 | Block Read Locked (Registers alterable) |
| 00000 | 1 | 0 | 1 | Block Read & Write Lock (Registers alterable) |
| 00000 | 1 | 1 | 0 | Block Read Locked Down (Registers not alterable) |
| 00000 | 1 | 1 | 1 | Block Read & Write lock Down (Registers not alterable) |

T15.0 20005029

Write-Lock Bit

The Write-Lock bit, bit 0, controls the lock state described in Table 15. The default Write status of all blocks after power up is write locked. When bit 0 of the Block Locking register is set, Program and Erase operations for the corresponding block are prevented. Clearing the Write-Lock bit will unprotect the block. The Write-Lock bit must be cleared prior to starting a Program or Erase operation since it is sampled at the beginning of the operation. The Write-Lock bit functions in conjunction with the hardware Write Lock pin TBL# for the top Boot Block. When TBL# is low, it overrides the software locking scheme. The top Boot Block Locking register does not indicate the state of the TBL# pin. The Write-Lock bit functions in conjunction with the hardware WP#/AAI pin for the remaining blocks (Blocks 0 to 33 for 49LF016C). When WP#/AAI is low, it overrides the software locking scheme. The Block Locking register does not indicate the state of the WP#/AAI pin.

Lock-Down Bit

The Lock-Down bit, bit 1, controls the Block Locking register as described in Table 15. When in LPC interface mode, the default Lock Down status of all blocks upon power-up is not locked down. Once the Lock-Down bit is set, any future attempted changes to that Block Locking register will be ignored. The Lock-Down bit is only cleared upon a device reset with RST# or INIT# or power down. Current Lock Down status of a particular block can be determined by reading the corresponding Lock-Down bit. Once a block's Lock-Down bit is set, the Read-Lock and Write-Lock bits for that block can no longer be modified: the block is locked down in its current state of read/write accessibility.

Read-Lock Bit

The default read status of all blocks upon power-up is read-unlocked. When a block's read lock bit is set, data cannot be read from that block. An attempted read from a read-locked block will result in the data 00h. The read lock status can be unlocked by clearing the read lock bit: this can only be done provided that the block is not locked down. The current read lock status of a particular block can be determined by reading the corresponding read-lock bit.

Security ID Registers

The SST49LF016C device offers a 256-bit Security ID register space. The Security ID space is divided into two segments - one (64-bits) factory programmed segment and one (192 bits) user programmed segment. The first segment is programmed and locked at SST with a unique 64-bit number. The user segment (192 bits) is left blank (FFH) for the customer to be programmed as desired. Refer to Table 8, "Software Command Sequence" for more details.

The Security ID Information and its Write Lock/Unlock status can be Read in the Register Access Space for Execute-In-Place type of applications. (See Table 16.)

The Write Lock-out status of the Security ID space can be read from the SEC_ID_WRITE_LOCK register (see Table 16). The SEC_ID_WRITE_LOCK register is a read-only register that is accessible at the address location specified in Table 16.

In case of multi-byte register reads with Firmware Memory cycle, for SEC_ID_WRITE_LOCK register, the device will return register data for the addressed register until the command finishes, or is aborted.

In the case of multi-byte register reads with Firmware Memory cycle, for all the SEC_ID_BYTE registers, the device will return page-aligned sequential register data with wrap-around until the command finishes, or is aborted.

Table 16: Security ID Registers

| Register | Register Address ¹ | Value | Access | Description |
|--------------------|-------------------------------|--------------------------|--------|--------------------------------|
| SEC_ID__WRITE_LOCK | FFBC0102H | 0000 0000b 0000 0001b | R | Write Unlocked Write Locked |
| SEC_ID_BYTE_0 | FFBC0180H | | R | Factory Programmed |
| SEC_ID_BYTE_1 | FFBC0181H | | R | Factory Programmed |
| SEC_ID_BYTE_2 | FFBC0182H | | R | Factory Programmed |
| SEC_ID_BYTE_3 | FFBC0183H | | R | Factory Programmed |
| ... | ... | | ... | ... |
| SEC_ID_BYTE_7 | FFBC0187H | | R | Factory Programmed |
| SEC_ID_BYTE_8 | FFBC0188H | | R | User Programmed |
| SEC_ID_BYTE_9 | FFBC0189H | | R | User Programmed |
| ... | ... | | ... | ... |
| SEC_ID_BYTE_30 | FFBC019EH | | R | User Programmed |
| SEC_ID_BYTE_31 | FFBC019FH | | R | User Programmed |

T16.0 20005029

1. Address shown in this column is for boot device only. Address locations should appear elsewhere in the 4 GByte system memory map depending on ID strapping values on ID[3:0] pins when multiple LPC memory devices are used in a system.

JEDEC ID Registers

The JEDEC ID registers for the boot device appear at FFBC0000H and FFBC0001H in the 4 GByte system memory map, and will appear elsewhere if the device is not the boot device. This register is not available to be read when the device is in Erase/Program operation. Unused register location will read as 00H. See Table 17 for the JEDEC device ID code. In case of multi-byte register reads with Firmware Memory cycle, the device will return register data for the addressed register until the command finishes, or is aborted.

Table 17: JEDEC ID Registers

| Register | Register Address ¹ | Default Value | Access |
|-----------|-------------------------------|---------------|--------|
| MANUF_REG | FFBC 0000H | BFH | R |
| DEV_REG | FFBC 0001H | 5CH | R |

T17.0 20005029

1. Address shown in this column is for boot device only. Address locations should appear elsewhere in the 4 GByte system memory map depending on ID strapping values on ID[3:0] pins when multiple LPC memory devices are used in a system.

Auto-Address Increment (AAI) MODE

AAI Mode with Multi-byte Programming

AAI mode with multi-byte programming is provided for high-speed production programming. Auto-Address Increment mode requires only one address load for each 128-byte page of data.

Taking the WP#/AAI pin to the Supervoltage V_H enables the AAI mode. The AAI command is started as a normal Firmware Memory cycle. LD# should be low (V_{IL}) as long as data is being loaded into the device. In the MADDR field, the host may input any address within the 128-byte page to be programmed. The least significant seven bits of the address field will be ignored and the device will begin programming at the beginning of the 128-byte page (i.e., the address will be page-aligned). The device Ready/Busy status is output on the RY/BY# pin.

Data is accepted until the internal buffer is full. At that point RY/BY# goes low (busy) to indicate that the internal buffer is full and cannot accept any more data. When the device is ready, RY/BY# pin goes high and indicates to the host that more data (the next group of bytes) can be accepted by the internal data buffer (see Table 18 and Figure 9).

After loading the final byte(s) of the 128-byte page, the RY/BY# signal remains low until the completion of internal programming. After the completion of programming, the part will go into idle mode and the RY/BY# will go high indicating that the AAI command has been completed (see Table 18). A subsequent AAI command may be initiated to begin programming the next 128-byte page.

Data will be accepted by the device as long as LD# is low and RY/BY# is high (until the last byte of the 128-byte page has been entered). For partial data-loads (i.e., less than 128 Bytes), LD# may be taken high (V_{IH}) to end the data loading. If LD# goes high before the full 128-byte page has been entered, the device will program the data which has been entered to that point, and then terminate the AAI page programming command. Any incompletely loaded data byte (nibble) will not be programmed. The device will signify completion of the command by driving RYBY# high. Once RY/BY# goes high, LD# can be taken low to begin a new AAI programming operation at a different address location.

The RY/BY# pin will stay low while internal programming completes. When the entire 128-byte page has been programmed, the device will return to the idle mode and the RY/BY# pin will go high (V_{IH}) to indicate the AAI command has been completed.

Table 18: LD# Input and RY/BY# Status in AAI Mode

| LD# state | RY/BY# status | RY/BY# Flag indication |
|-----------|---------------|--|
| L | H | Device is Ready, can accept more data until the last (128 th) byte. |
| L | L | Device is Busy, cannot accept more data |
| L | H | Device is Ready for next operation if previous data is the last (128 th) byte. |
| H | H | Device is Ready for next operation |
| H | L | Device is Busy programming |

T18.1 20005029

The user may terminate AAI programming by dropping the WP#/AAI pin to TTL levels (V_{IH}/V_{IL}) as long as LD# is high and RY/BY# returns to high indicating the completion of the AAI cycle. Software block-locking will be disabled in AAI mode (all blocks will be write-unlocked). If AAI drops below the Super-voltage V_H before RY/BY# returns to high (and LD# high), the contents of the page may be indeterminate.

AAI Data Load Protocol

Table 19: AAI Programming Cycle (initiated with WP#/AAI at V_H ONLY)

| Clock Cycle | Field Name | Field Contents | LAD[3:0] | Comments |
|-------------|------------|----------------|----------|--|
| 1 | START | 1110 | IN | LFRAME# must be active (low) for the part to respond. Only the last start field (before LFRAME# transitions high) should be recognized. The START field contents indicate a Firmware Memory Write cycle. (1110b) |
| 2 | IDSEL | 0000b to 1111b | IN | ID works identically to Firmware Memory cycle. This field indicates which SST49LF016C device should respond. If the IDSEL (ID select) field matches the value of ID[3:0], then that particular device will respond to the whole bus cycle. |
| 3-9 | MADDR | YYYY | IN | These seven clock cycles make up the 28-bit memory address. YYYY is one nibble of the entire address. Addresses are transferred most-significant nibble first. Only bits [20:7] of the total address [27:0] are used for AAI mode. The rest are "don't care". |
| 10 | MSIZE | KKKK | IN | MSIZE field is don't care when in AAI mode |
| 11-266 | DATA | ZZZZ | IN | Data is transmitted to the device least significant nibble first, from byte 0 to byte 127 as long as the RY/BY# is high and LD# low. The host will pause the clock and data stream when RY/BY# goes low until it returns high, signifying that the chip is ready for more data |

T19.0 20005029

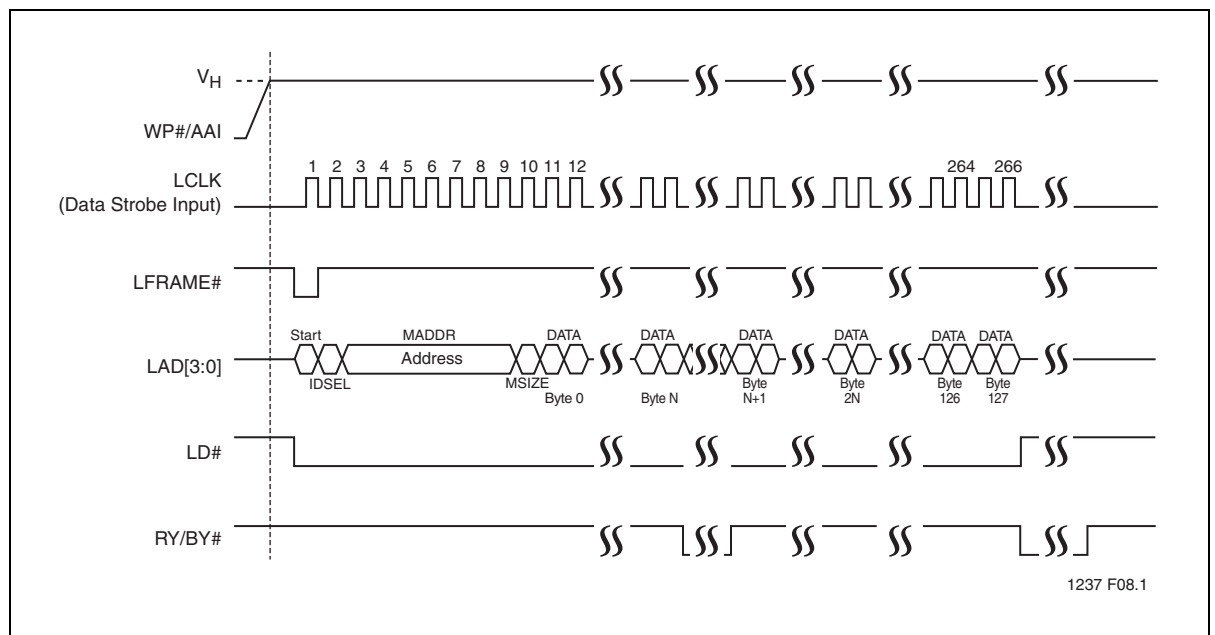

1237 F08.1

Figure 9: AAI Load Protocol Waveform

Electrical Specifications

The AC and DC specifications for the LPC interface signals (LAD[3:0], LFRAME#, LCLK and RST#) as defined in Section 4.2.2.4 of the PCI local Bus specification, Rev. 2.1. Refer to Table 22 for the DC voltage and current specifications. Refer to Table 26 through Table 28 for the AC timing specifications for Clock, Read, Write, and Reset operations.

Absolute Maximum Stress Ratings (Applied conditions greater than those listed under “Absolute Maximum Stress Ratings” may cause permanent damage to the device. This is a stress rating only and functional operation of the device at these conditions or conditions greater than those defined in the operational sections of this data sheet is not implied. Exposure to absolute maximum stress rating conditions may affect device reliability.)

| | |
|---|--------------------------------|
| Temperature Under Bias | -55°C to +125°C |
| Storage Temperature | -65°C to +150°C |
| D.C. Voltage on Any Pin to Ground Potential | -0.5V to V _{DD} +0.5V |
| Transient Voltage (<20 ns) on Any Pin (except WP#/AAI) to Ground Potential ¹ | -2.0V to V _{DD} +2.0V |
| Voltage on WP#/AAI Pin to Ground Potential ² | -0.5V to 11.0V |
| Package Power Dissipation Capability (T _A =25°C) | 1.0W |
| Surface Mount Solder Reflow Temperature ³ | 260°C for 10 seconds |
| Output Short Circuit Current ⁴ | 50 mA |

1. Do not violate processor or chipset specification regarding INIT# voltage.
2. The maximum DC voltage on WP#/AAI pin may reach 11V for periods <20ns.
3. Excluding certain with-Pb 32-PLCC units, all packages are 260°C capable in both non-Pb and with-Pb solder versions. Certain with-Pb 32-PLCC package types are capable of 240°C for 10 seconds; please consult the factory for the latest information.
4. Outputs shorted for no more than one second. No more than one output shorted at a time.

Table 20: Operating Range

| Range | Ambient Temp | V _{DD} |
|------------|--------------|-----------------|
| Commercial | 0°C to +70°C | 3.0-3.6V |

T20.1 20005029

Table 21: AC Conditions of Test¹

| Input Rise/Fall Time | Output Load |
|----------------------|------------------------|
| 3 ns | C _L = 30 pF |

T21.1 20005029

1. See Figures 15 and 16

DC Characteristics

Table 22: DC Operating Characteristics at 33 MHz and 66 MHz (All Interfaces)

| Symbol | Parameter | Limits | | | Test Conditions |
|------------|--|-----------------|--------------|---------|--|
| | | Min | Max | Units | |
| I_{DD}^1 | Active V_{DD} Current | | | | LCLK (LPC mode)= V_{ILT}/V_{IHT} All other inputs= V_{IL} or V_{IH} All outputs = open, $V_{DD}=V_{DD}$ Max |
| | Read | | 18 | mA | |
| | Single-/Dual-Byte Program, Erase | | 40 | mA | |
| | Quad-Byte Program | | 60 | mA | |
| I_{SB} | Standby V_{DD} Current (LPC Interface) | | 100 | μ A | LCLK (LPC mode)= V_{ILT}/V_{IHT} at LFRAME#= $.9V_{DD}$ $V_{DD}=V_{DD}$ Max All other inputs $\geq 0.9 V_{DD}$ or $\leq 0.1 V_{DD}$ |
| I_{RY}^2 | Ready Mode V_{DD} Current | | 10 | mA | LCLK (LPC mode)= V_{ILT}/V_{IHT} LFRAME#= V_{IL} , $V_{DD}=V_{DD}$ Max All other inputs $\geq 0.9 V_{DD}$ or $\leq 0.1 V_{DD}$ |
| I_I | Input Leakage Current for ID[3:0] pins | | 200 | μ A | $V_{IN}=GND$ to V_{DD} , $V_{DD}=V_{DD}$ Max |
| I_{LI} | Input Leakage Current | | 1 | μ A | $V_{IN}=GND$ to V_{DD} , $V_{DD}=V_{DD}$ Max |
| I_{LO} | Output Leakage Current | | 1 | μ A | $V_{OUT}=GND$ to V_{DD} , $V_{DD}=V_{DD}$ Max |
| I_H | Supervoltage Current for WP#/AAI | | 200 | μ A | |
| V_H | Supervoltage for WP#/AAI | 8.5 | 9.5 | V | |
| V_{IH}^3 | INIT# Input High Voltage | 1.1 | $V_{DD}+0.5$ | V | $V_{DD}=V_{DD}$ Max |
| V_{IL}^3 | INIT# Input Low Voltage | -0.5 | 0.4 | V | $V_{DD}=V_{DD}$ Min |
| V_{IL} | Input Low Voltage | -0.5 | $0.3 V_{DD}$ | V | $V_{DD}=V_{DD}$ Min |
| V_{IH} | Input High Voltage | 0.5 V_{DD} | $V_{DD}+0.5$ | V | $V_{DD}=V_{DD}$ Max |
| V_{OL} | Output Low Voltage | | $0.1 V_{DD}$ | V | $I_{OL}=1500 \mu$ A, $V_{DD}=V_{DD}$ Min |
| V_{OH} | Output High Voltage | 0.9 V_{DD} | | V | $I_{OH}=-500 \mu$ A, $V_{DD}=V_{DD}$ Min |

T22.1 20005029

- I_{DD} active while a Read or Write (Program or Erase) operation is in progress.
- The device is in Ready mode when no activity is on the LPC bus.
- Do not violate processor or chipset specification regarding INIT# voltage.

Table 23: Recommended System Power-up Timings

| Symbol | Parameter | Minimum | Units |
|------------------|-----------------------------|---------|---------|
| $T_{PU-READ}^1$ | Power-up to Read Operation | 100 | μ s |
| $T_{PU-WRITE}^1$ | Power-up to Write Operation | 100 | μ s |

T23.0 20005029

- This parameter is measured only for initial qualification and after a design or process change that could affect this parameter

Table 24: Pin Capacitance ($V_{DD}=3.3V$, $T_A=25\text{ }^\circ\text{C}$, $f=1\text{ Mhz}$, other pins open)

| Parameter | Description | Test Condition | Maximum |
|-------------|---------------------|----------------|---------|
| $C_{I/O}^1$ | I/O Pin Capacitance | $V_{I/O}=0V$ | 12 pF |
| C_{IN}^1 | Input Capacitance | $V_{IN}=0V$ | 12 pF |
| L_{PIN}^2 | Pin Inductance | | 20 nH |

T24.0 20005029

1. This parameter is measured only for initial qualification and after a design or process change that could affect this parameter.
2. Refer to PCI spec.

Table 25: Reliability Characteristics

| Symbol | Parameter | Minimum Specification | Units | Test Method |
|-------------|----------------|-----------------------|--------|---------------------|
| N_{END}^1 | Endurance | 10,000 | Cycles | JEDEC Standard A117 |
| T_{DR}^1 | Data Retention | 100 | Years | JEDEC Standard A103 |
| I_{LTH}^1 | Latch Up | $100 + I_{DD}$ | mA | JEDEC Standard 78 |

T25.0 20005029

1. This parameter is measured only for initial qualification and after a design or process change that could affect this parameter.

Table 26: Clock Timing Parameters (LPC Mode)

| Symbol | Parameter | 33 MHz | | 66 MHz | | Units |
|------------|-------------------------------|--------|-----|--------|-----|-------|
| | | Min | Max | Min | Max | |
| T_{CYC} | Cycle Time | 30 | | 15 | | ns |
| T_{HIGH} | LCLK High Time | 11 | | 6.5 | | ns |
| T_{LOW} | LCLK Low Time | 11 | | 6.5 | | ns |
| - | LCLK Slew Rate (peak-to-peak) | 1 | 4 | 1 | 4 | V/ns |
| - | RST# or INIT# Slew Rate | 50 | | 50 | | mV/ns |

T26.0 20005029

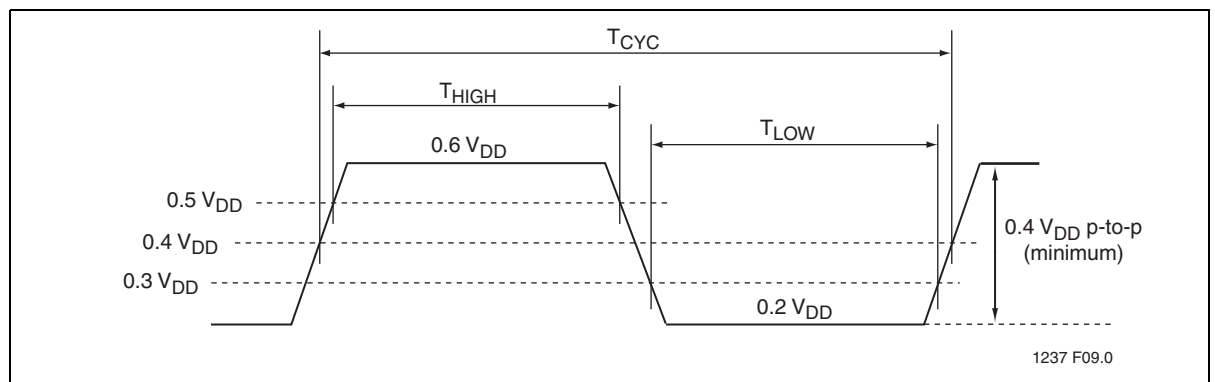

Figure 10: LCLK Waveform (LPC Mode)

Table 27: Reset Timing Parameters, $V_{DD}=3.0-3.6V$ (LPC Mode)

| Symbol | Parameter | Min | Max | Units |
|-------------|---|-----|-----|-------------|
| T_{PRST} | V_{DD} stable to Reset High | 100 | | μs |
| T_{RSTP} | RST# Pulse Width | 100 | | ns |
| T_{RSTF} | RST# Low to Output Float | | 48 | ns |
| T_{RST}^1 | RST# High to LFRAME# Low | 5 | | LCLK cycles |
| T_{RSTE} | RST# Low to reset during Sector-/Block-Erase or Program | | 10 | μs |

T27.0 20005029

1. There will be a latency due to T_{RSTE} if a reset procedure is performed during a Program or Erase operation,

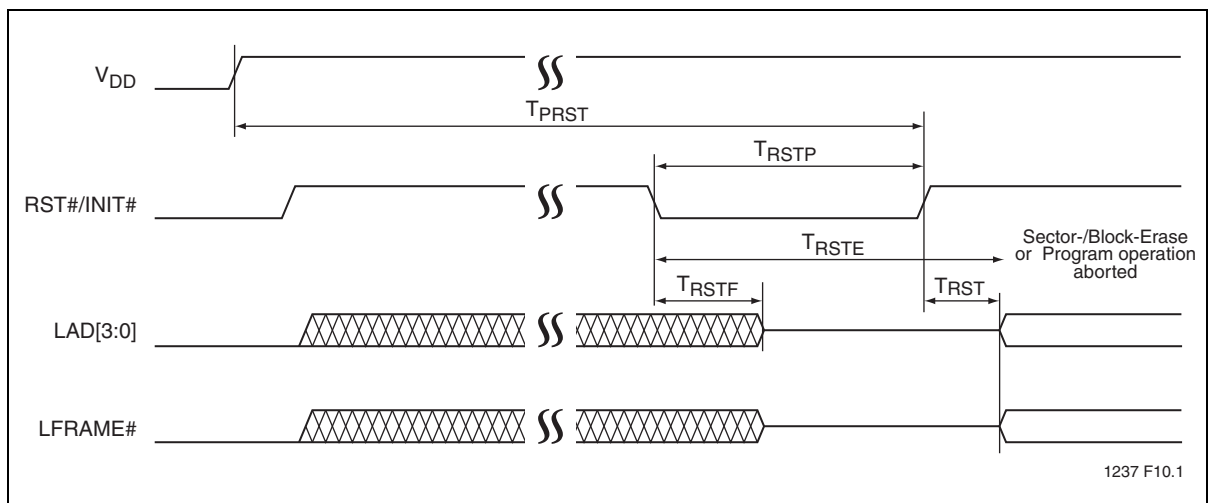

1237 F10.1

Figure 11: Reset Timing Diagram (LPC Mode)

AC Characteristics

Table 28: Read/Write Cycle Timing Parameters, $V_{DD}=3.0-3.6V$ (LPC Mode)

| Symbol | Parameter | 33 MHz | | 66 MHz | | Units |
|-------------|--|--------|-----|--------|-----|---------|
| | | Min | Max | Min | Max | |
| T_{CYC} | Clock Cycle Time | 30 | | 15 | | ns |
| T_{SU} | Data Set Up Time to Clock Rising | 7 | | 7 | | ns |
| T_{DH} | Clock Rising to Data Hold Time | 0 | | 0 | | ns |
| T_{VAL}^1 | Clock Rising to Data Valid | 2 | 11 | 2 | 7 | ns |
| T_{BP} | Byte Programming Time | | 10 | | 10 | μs |
| T_{SE} | Sector-Erase Time | | 25 | | 25 | ms |
| T_{BE} | Block-Erase Time | | 25 | | 25 | ms |
| T_{ES} | Program/Erase-Suspend Latency | | 10 | | 10 | μs |
| T_{ON} | Clock Rising to Active (Float to Active Delay) | 2 | | 2 | | ns |
| T_{OFF} | Clock Rising to Inactive (Active to Float Delay) | | 28 | | 28 | ns |

T28.0 20005029

1. Minimum and maximum times have different loads. See PCI spec

Table 29: AC Input/Output Specifications (LPC Mode)

| Symbol | Parameter | Min | Max | Units | Conditions |
|--------------|--|------------------------------|---|-------|---|
| $I_{OH(AC)}$ | Switching Current High (Test Point) | -12 V_{DD} | Equation C ¹ -32 V_{DD} | mA | $0 < V_{OUT} \leq 0.3V_{DD}$ |
| | | -17.1($V_{DD}-V_{OUT}$) | | mA | $0.3V_{DD} < V_{OUT} < 0.9V_{DD}$ |
| | | | | mA | $0.7V_{DD} < V_{OUT} < V_{DD}$ $V_{OUT} = 0.7V_{DD}$ |
| $I_{OL(AC)}$ | Switching Current Low (Test Point) | 16 V_{DD} | Equation D ¹ 38 V_{DD} | mA | $V_{DD} > V_{OUT} \geq 0.6V_{DD}$ |
| | | 26.7 V_{OUT} | | mA | $0.6V_{DD} > V_{OUT} > 0.1V_{DD}$ |
| | | | | mA | $0.18V_{DD} > V_{OUT} > 0$ $V_{OUT} = 0.18V_{DD}$ |
| I_{CL} | Low Clamp Current | $-25+(V_{IN}+1)/0.015$ | | mA | $-3 < V_{IN} \leq -1$ |
| I_{CH} | High Clamp Current | $25+(V_{IN}-V_{DD}-1)/0.015$ | | mA | $V_{DD}+4 > V_{IN} \geq V_{DD}+1$ |
| $slewr^2$ | Output Rise Slew Rate | 1 | 4 | V/ns | 0.2 V_{DD} -0.6 V_{DD} load |
| $slewf^2$ | Output Fall Slew Rate | 1 | 4 | V/ns | 0.6 V_{DD} -0.2 V_{DD} load |

T29.0 20005029

1. See PCI spec.
2. PCI specification output load is used.

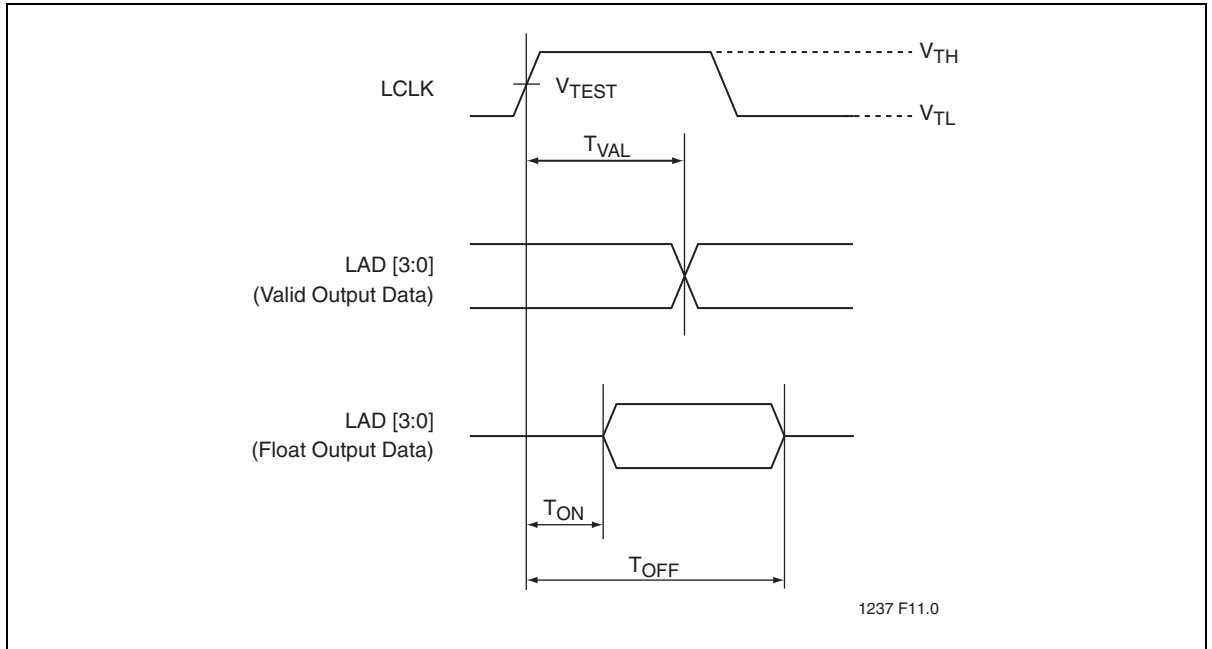

Figure 12:Output Timing parameters (LPC Mode)

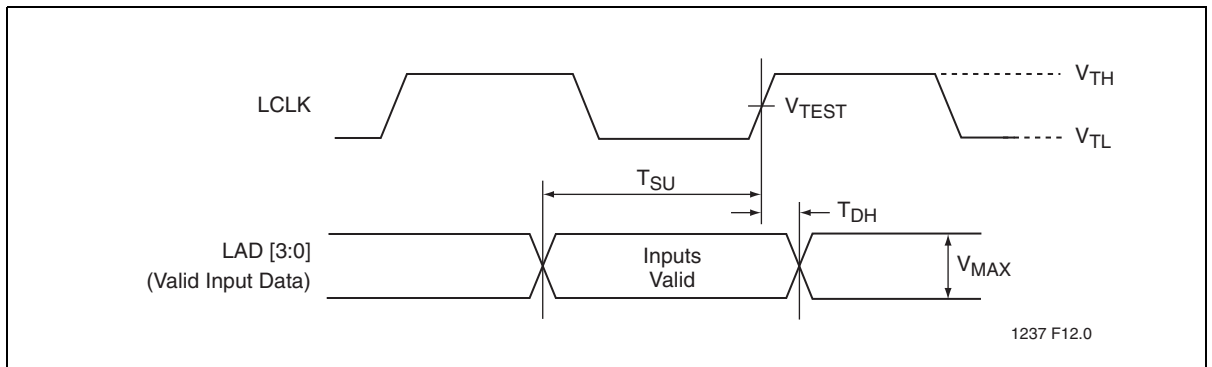

Figure 13:Input Timing Parameters (LPC Mode)

Table 30:Interface Measurement Condition Parameters (LPC Mode)

| Symbol | Value | Units |
|------------------------|--------------|-------|
| V_{TH}^1 | $0.6 V_{DD}$ | V |
| V_{TL}^1 | $0.2 V_{DD}$ | V |
| V_{TEST} | $0.4 V_{DD}$ | V |
| V_{MAX}^1 | $0.4 V_{DD}$ | V |
| Input Signal Edge Rate | 1 | V/ns |

T30.0 20005029

1. The input test environment is done with $0.1 V_{DD}$ of overdrive over V_{IH} and V_{IL} . Timing parameters must be met with no more overdrive than this. V_{MAX} specifies the maximum peak-to-peak waveform allowed for measuring input timing. Production testing may use different voltage values, but must correlate results back to these parameters.

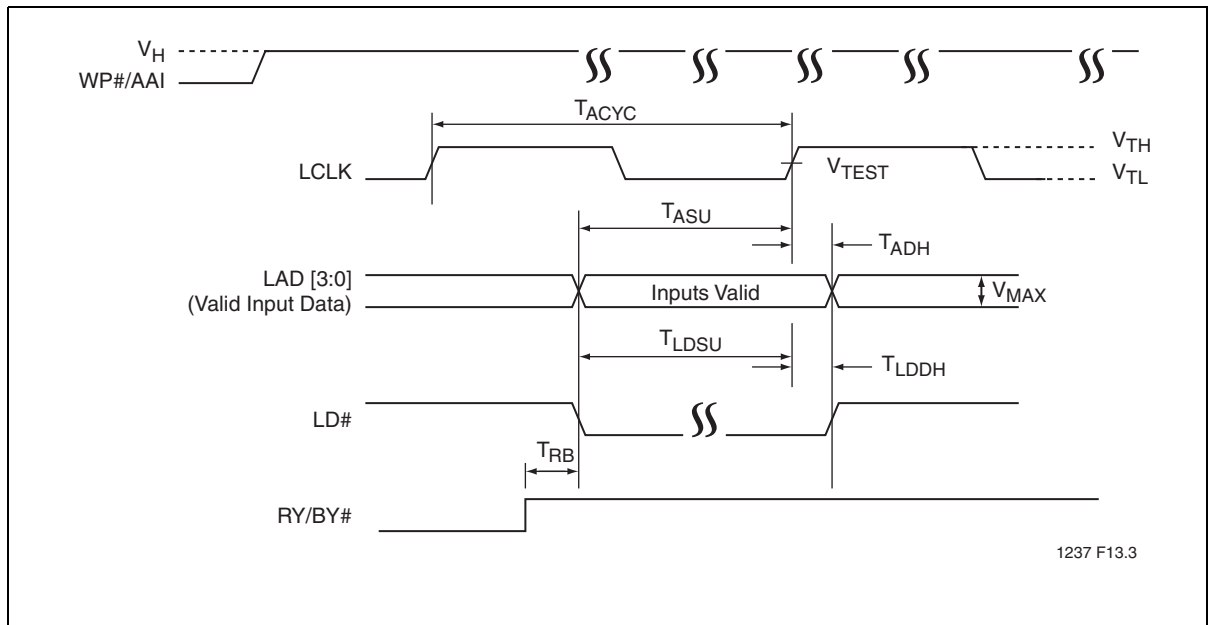

Figure 14: Input Timing Parameters (AAI Mode)

Table 31: Input Cycle Timing Parameters, $V_{DD}=3.0-3.6V$ (AAI Mode)

| Symbol | Parameter | Min | Max | Units |
|-------------|----------------------------------|-----|-----|-------|
| T_{ACYC} | Clock Cycle Time | 135 | | ns |
| T_{ASU} | Data Set Up Time to Clock Rising | 25 | | ns |
| T_{ADH} | Clock Rising to Data Hold Time | 25 | | ns |
| T_{RB} | RY/BY# LD# Falling | 25 | | ns |
| T_{LDSDU} | LD# Set Up Time | 25 | | ns |
| T_{LDDH} | LD# Hold Time | 25 | | ns |

T31.3 20005029

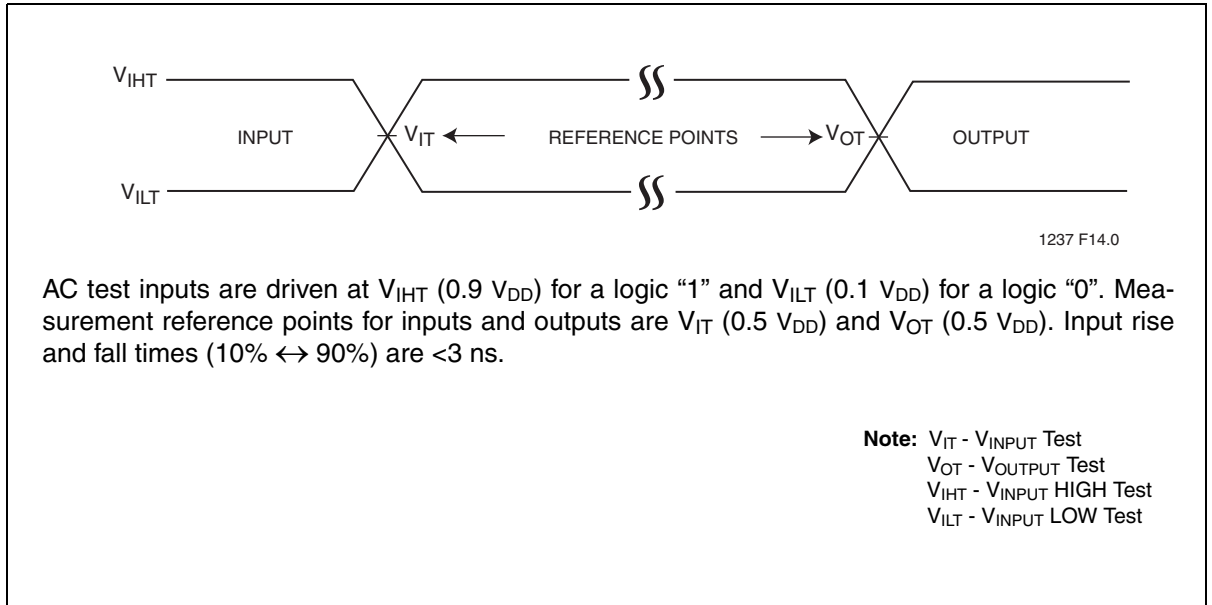

Figure 15: AC Input/Output Reference Waveforms

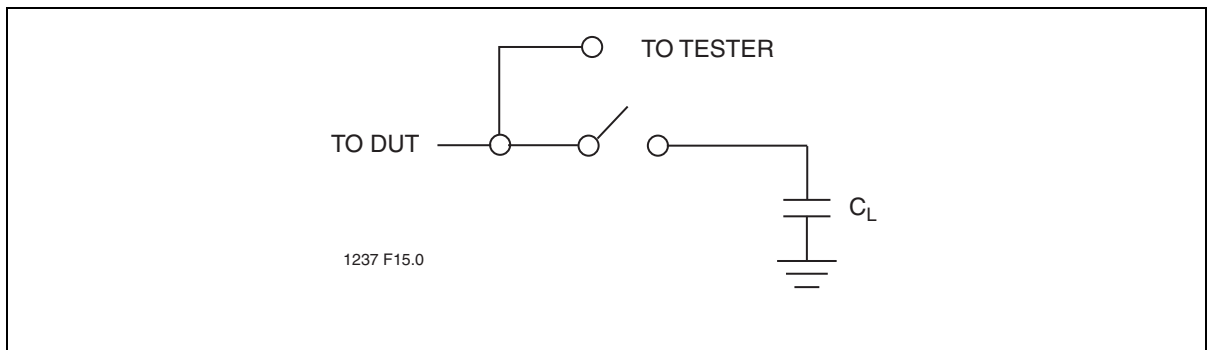
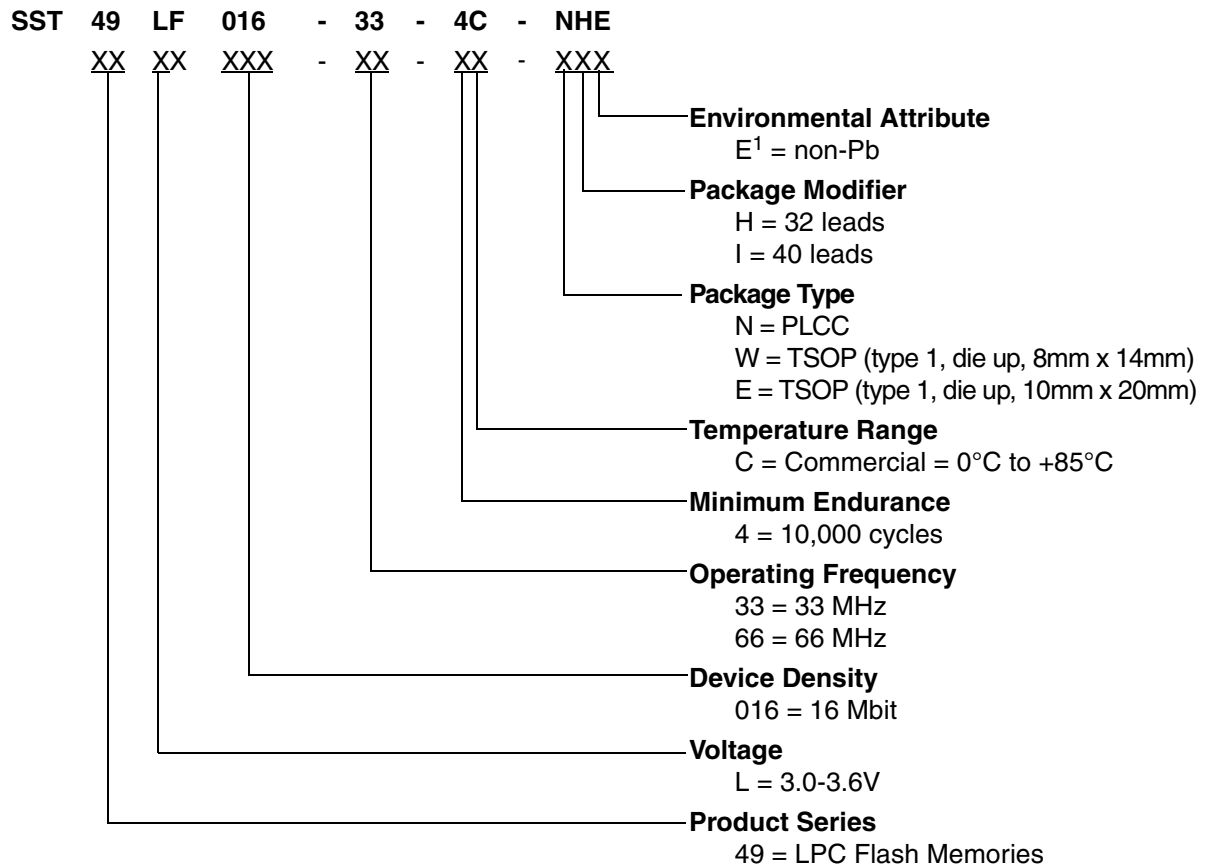

Figure 16: A Test Load Example

Product Ordering Information



1. Environmental suffix "E" denotes non-Pb solder. SST non-Pb solder devices are "RoHS Compliant".

Valid combinations for SST49LF016C

- SST49LF016C-33-4C-NHE SST49LF016C-33-4C-WHE
- SST49LF016C-33-4C-EIE
- SST49LF016C-66-4C-NHE SST49LF016C-66-4C-WHE

Note: Valid combinations are those products in mass production or will be in mass production. Consult your SST sales representative to confirm availability of valid combinations and to determine availability of new combinations.

Packaging Diagrams

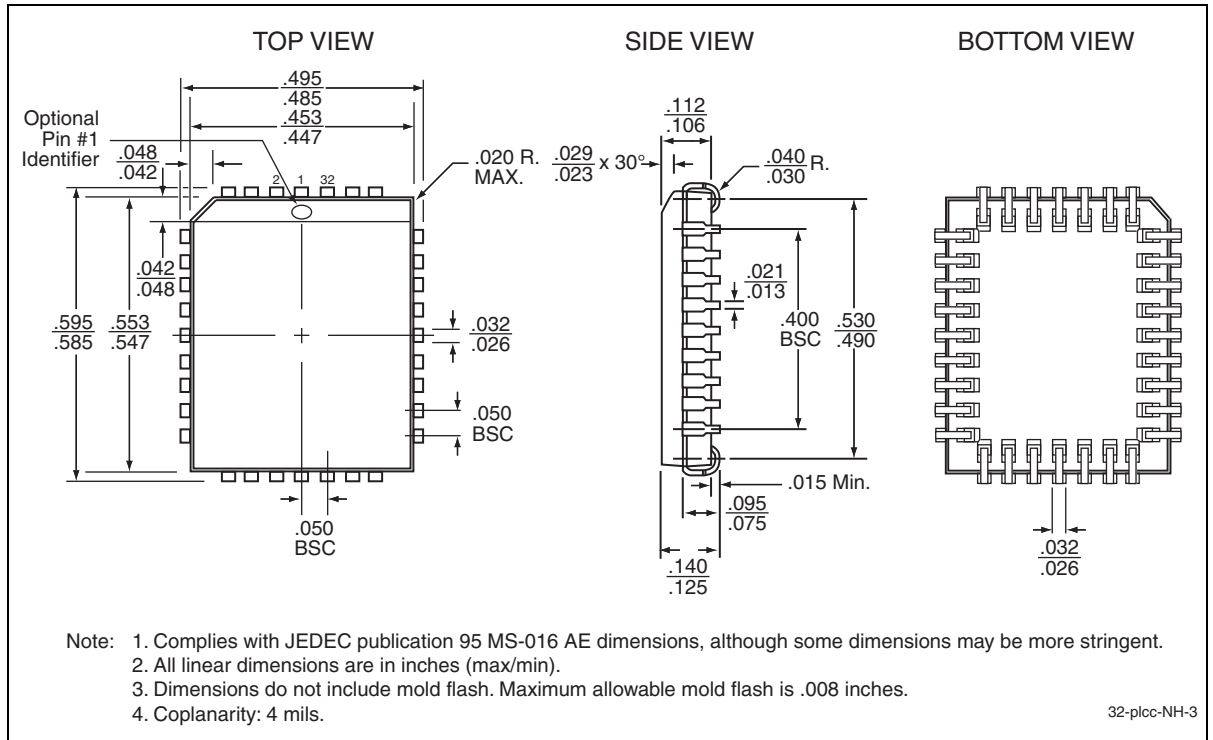

Figure 17: 32-lead Plastic Lead Chip Carrier (PLCC)
 SST Package Code: NH

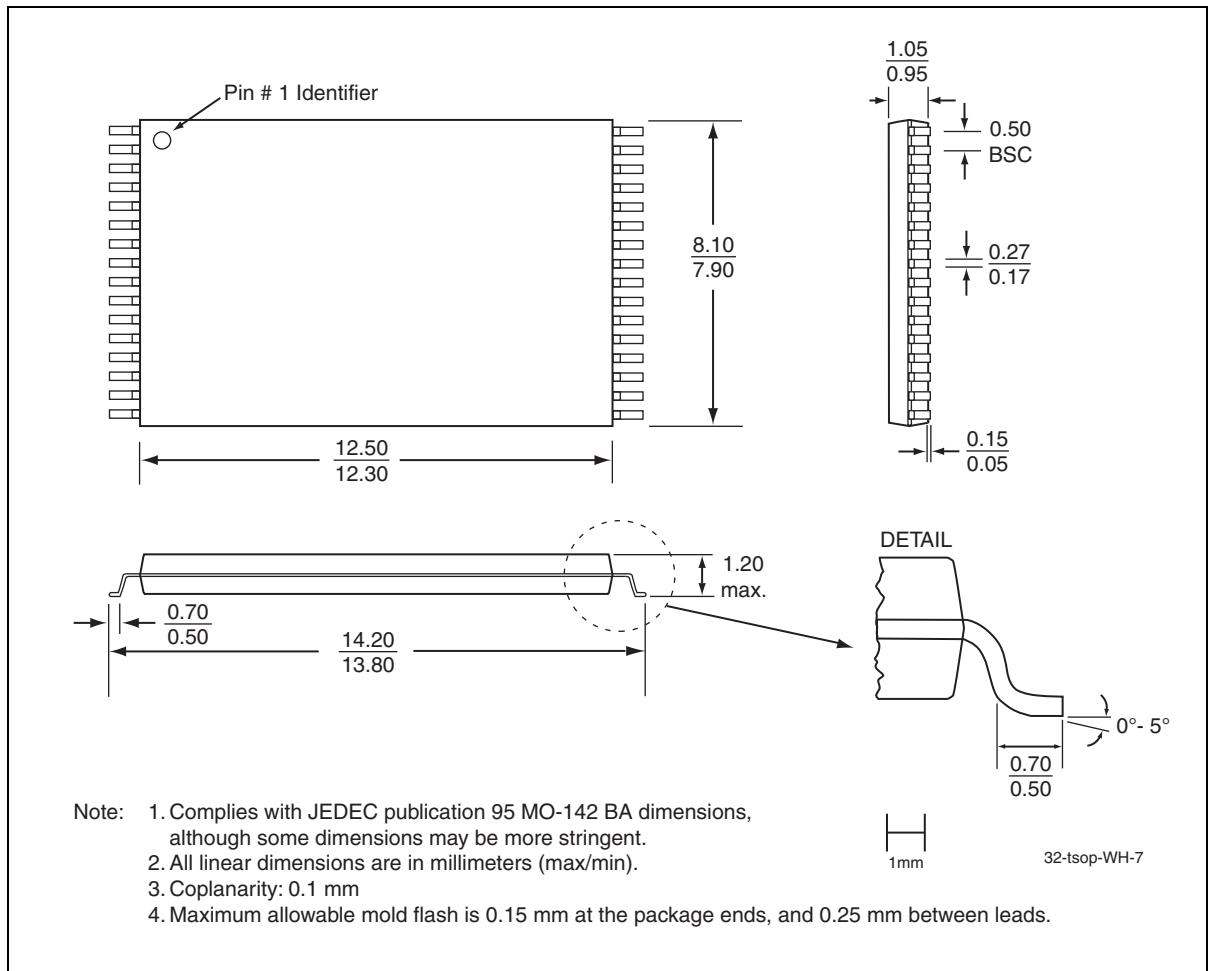

Figure 18:32-lead Thin Small Outline Package (TSOP) 8mm x 14mm
 SST Package Code: WH

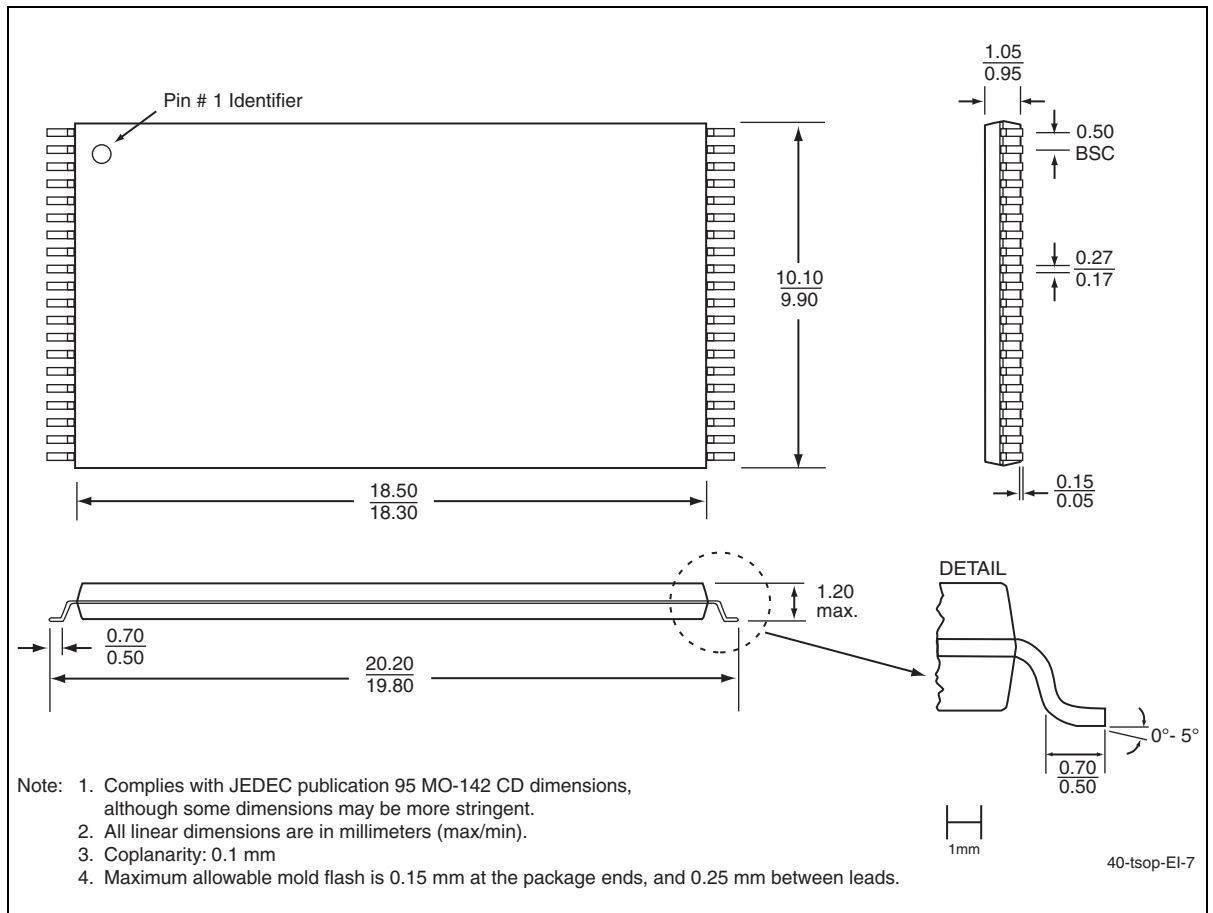

Figure 19:40-lead Thin Small Outline Package (TSOP) 10mm x 20mm
SST Package Code: EI

Table 32: Revision History

| Revision | Description | Date |
|----------|--|----------|
| 00 | <ul style="list-style-type: none"> S71237(01): Initial release of fact sheet (Advance Information) | Oct 2003 |
| 01 | <ul style="list-style-type: none"> S71237(01): Fact sheet changes 2004 Flash Data Book | Nov 2003 |
| 02 | <ul style="list-style-type: none"> S71237(01): Fact sheet synchronized to and integrated into full data sheet S71237: Initial release of data sheet (Advance Information) Added Auto-Address Increment (AAI) mode | Apr 2004 |
| 03 | <ul style="list-style-type: none"> Added 32-TSOP (WH/WHE) package and associated MPNs Clarified Supervoltage for AAI mode Clarified the solder temperature profile under “Absolute Maximum Stress Ratings” on page 30 | Dec 2004 |
| 04 | <ul style="list-style-type: none"> Obsoleted stand-alone Fact Sheet S71237(01) Changed to firmware protocol-only data sheet Removed the EI package and related MPNs Added RoHS compliance information on page 1 and in the “Product Ordering Information” on page 38 Updated the surface mount lead temperature from 240°C to 260°C and the time from 3 seconds to 10 seconds on page 30. | Jul 2005 |
| 05 | <ul style="list-style-type: none"> Removed leaded part numbers | Jan 2006 |
| 06 | <ul style="list-style-type: none"> Cosmetic update to Figure 3 | Feb 2006 |
| 07 | <ul style="list-style-type: none"> Revised Product Description. Added 66 MHz information to Features. Added 66 MHz values to Table 26, and Table 28. Added “33 MHz and 66 MHz” to Table title and removed f=33 MHz from table cells in Table 22. | Sep 2006 |
| 08 | <ul style="list-style-type: none"> Added 40-lead TSOP Pin Assignment and Package Drawing. Updated Product Ordering information | May 2008 |
| A | <ul style="list-style-type: none"> Applied new document format Released document under letter revision system Updated spec number from S71237to DS25029 | Jun 2011 |
| B | <ul style="list-style-type: none"> EOL of allSST49LF016C devices. See PCN # JAON-29GFSU603 Document marked Obsolete. | Feb 2016 |



16 Mbit LPC Serial Flash SST49LF016C

EOL Data Sheet

ISBN:978-1-5224-0278-7

© 2016 Microchip Technology Inc.

SST, Silicon Storage Technology, the SST logo, SuperFlash, and MTP are registered trademarks of Microchip Technology, Inc. MPF, SQI, Serial Quad I/O, and Z-Scale are trademarks of Microchip Technology, Inc. All other trademarks and registered trademarks mentioned herein are the property of their respective owners.

Specifications are subject to change without notice. Refer to www.microchip.com for the most recent documentation. For the most current package drawings, please see the Packaging Specification located at <http://www.microchip.com/packaging>.

Memory sizes denote raw storage capacity; actual usable capacity may be less.

Microchip makes no warranty for the use of its products other than those expressly contained in the Standard Terms and Conditions of Sale.

For sales office locations and information, please see www.microchip.com.

www.microchip.com
