

Features

- Fast Zero Power (FZP) design technique provides ultra-low power and very high speed
 - Typical Standby Current of 17 to 18 μA at 25°C
- Innovative CoolRunner™ XPLA3 architecture combines high speed with extreme flexibility
- Based on industry's first TotalCMOS PLD — both CMOS design and process technologies
- Advanced 0.35 μm five layer metal EEPROM process
 - 1,000 erase/program cycles guaranteed
 - 20 years data retention guaranteed
- 3V, In-System Programmable (ISP) using JTAG IEEE 1149.1 interface
 - Full Boundary-Scan Test (IEEE 1149.1)
 - Fast programming times
- Support for complex asynchronous clocking
 - 16 product term clocks and four local control term clocks per function block
 - Four global clocks and one universal control term clock per device
- Excellent pin retention during design changes
- Available in commercial grade and extended voltage (2.7V to 3.6V) industrial grade
- 5V tolerant I/O pins
- Input register setup time of 2.5 ns
- Single pass logic expandable to 48 product terms
- High-speed pin-to-pin delays of 5.0 ns
- Slew rate control per output
- 100% routable
- Security bit prevents unauthorized access
- Supports hot-plugging capability
- Design entry/verification using Xilinx or industry standard CAE tools
- Innovative Control Term structure provides:
 - Asynchronous macrocell clocking
 - Asynchronous macrocell register preset/reset
 - Clock enable control per macrocell
- Four output enable controls per function block
- Foldback NAND for synthesis optimization
- Universal 3-state which facilitates "bed of nails" testing
- Available in Chip-scale BGA, Fineline BGA, and QFP packages. Pb-free available for most package types. See [Xilinx Packaging](#) for more information.

Table 1: CoolRunner XPLA3 Device Family

	XCR3032XL	XCR3064XL	XCR3128XL	XCR3256XL	XCR3384XL	XCR3512XL
Macrocells	32	64	128	256	384	512
Usable Gates	750	1,500	3,000	6,000	9,000	12,000
Registers	32	64	128	256	384	512
T _{PD} (ns)	4.5	5.5	5.5	7.0	7.0	7.0
T _{SU} (ns)	3.0	3.5	3.5	4.3	4.3	3.8
T _{CO} (ns)	3.5	4	4	4.5	4.5	5.0
F _{system} (MHz)	213	192	175	154	135	135
I _{CCSB} (μA)	17	17	17	18	18	18

Table 2: CoolRunner XPLA3 Packages and User I/O Pins

	XCR3032XL	XCR3064XL	XCR3128XL	XCR3256XL	XCR3384XL	XCR3512XL
44-pin VQFP	36	36	-	-	-	-
48-pin 0.8mm CSP	36	40	-	-	-	-
56-pin 0.5mm CSP	-	48	-	-	-	-
100-pin VQFP	-	68	84	-	-	-
144-pin 0.8mm CSP	-	-	108	-	-	-
144-pin TQFP	-	-	108	120	118 ⁽¹⁾	-
208-pin PQFP	-	-	-	164	172	180
256-pin Fineline BGA	-	-	-	164	212	212
280-pin 0.8mm CSP	-	-	-	164	-	-
324-pin Fineline BGA	-	-	-	-	220	260

- XCR3384XL TQ144 JTAG pins are not compatible with other members of the CoolRunner XPLA3 family in the TQ144 package.
- Most packages are available in Pb-Free option. See individual data sheets for more details.
- The 44-pin PLCC package is discontinued per XCN07022.

Family Overview

The CoolRunner XPLA3 (eXtended Programmable Logic Array) family of CPLDs is targeted for low power systems that include portable, handheld, and power sensitive applications. Each member of the CoolRunner XPLA3 family includes Fast Zero Power (FZP) design technology that combines low power and high speed. With this design technique, the CoolRunner XPLA3 family offers true pin-to-pin speeds of 5.0 ns, while simultaneously delivering power that is less than 56 μ W at standby without the need for "turbo bits" or other power down schemes. By replacing conventional sense amplifier methods for implementing product terms (a technique that has been used in PLDs since the bipolar era) with a cascaded chain of pure CMOS gates, the dynamic power is also substantially lower than any other CPLD. CoolRunner devices are the only Total-CMOS PLDs, as they use both a CMOS process technology and the patented full CMOS FZP design technique. The FZP design technique combines fast nonvolatile memory cells with ultra-low power SRAM shadow memory to deliver the industry's lowest power 3.3V CPLD family.

The CoolRunner XPLA3 family employs a full PLA structure for logic allocation within a function block. The PLA provides maximum flexibility and logic density, with superior pin locking capability, while maintaining deterministic timing.

CoolRunner XPLA3 CPLDs are supported by Xilinx® WebPACK™ software and industry standard CAE tools (Mentor, Cadence/OrCAD, Exemplar Logic, Synopsys, Viewlogic, and Synplicity), using HDL editors with ABEL, VHDL, and Verilog, and/or schematic capture design entry. Design verification uses industry standard simulators for functional and timing simulation. Development is supported on multiple personal computer (PC), Sun, and HP platforms.

The CoolRunner XPLA3 family features also include the industry-standard, IEEE 1149.1, JTAG interface through which boundary-scan testing, In-System Programming (ISP), and reprogramming of the device can occur. The CoolRunner XPLA3 CPLD is electrically reprogrammable using industry standard device programmers.

CoolRunner XPLA3 Architecture

Figure 1 shows a high-level block diagram of a 128 macrocell device implementing the CoolRunner XPLA3 architecture. The CoolRunner XPLA3 architecture consists of function blocks that are interconnected by a Zero-power

Interconnect Array (ZIA). The ZIA is a virtual crosspoint switch. Each function block has 40 inputs from the ZIA and contains 16 macrocells.

From this point of view, this architecture looks like many other CPLD architectures. What makes the CoolRunner XPLA3 family unique is logic allocation inside each function block, and the design technique used to implement product terms.

Function Block Architecture

Figure 3 illustrates the function block architecture. Each function block contains a PLA array that generates control terms, clock terms, and logic cells. A PLA differs from a PAL in that the PLA has a fully programmable AND array followed by a fully programmable OR array. A PAL array has a fixed OR array, limiting flexibility. Refer to Figure 2 for an example of a PAL and a PLA array. The PLA array receives its inputs directly from the ZIA. There are 40 pairs of true and complement inputs from the ZIA that feed the 48 product terms in the array. Within the 48 P-terms there are eight local control terms (LCT[0:7]) available as control signals to each macrocell for use as asynchronous clocks, resets, presets and output enables. If not needed as control terms, these P-Terms can join the other 40 P-Terms as additional logic resources.

In each function block there are eight foldback NAND product terms that can be used to synthesize increased logic density in support of wider logic equations. This feature can be disabled in software by the user. As with unused control P-Terms, unused foldback NAND P-Terms can be used as additional logic resources.

Sixteen high-speed P-Terms are available at each macrocell for speed critical logic. If wider than a single P-Term logic is required at a macrocell, 47 additional P-Terms can be summed in prior to the VFM (Variable Function Multiplexer). The VFM increases logic optimization by implementing some two input logic functions before entering the macrocell (see Figure 4).

Each macrocell can support combinatorial or registered logic. The macrocell register accommodates asynchronous presets and resets, and "power on" initial state. A hardware clock enable is also provided for either D or T type registers, and the register clock input is used as a latch enable when the macrocell register is configured as a latch function.

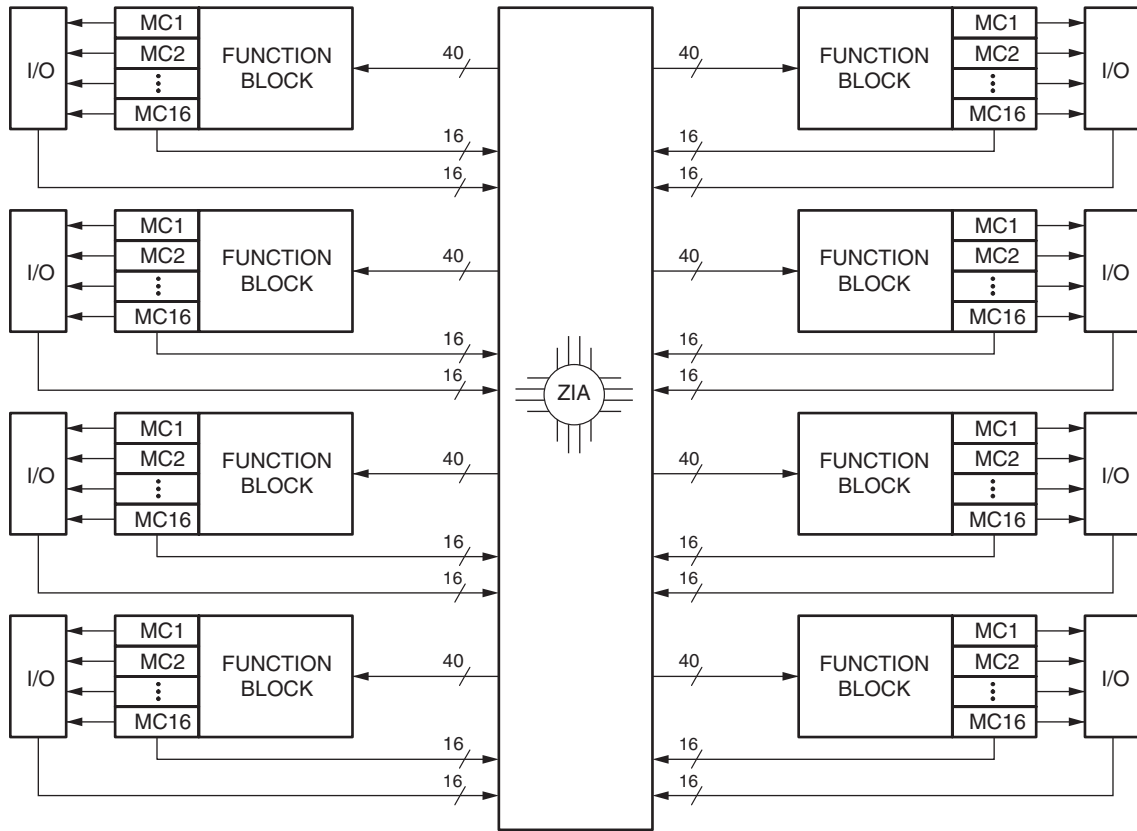

DS012_01_112000

Figure 1: Xilinx XPLA3 CPLD Architecture

PLA Array

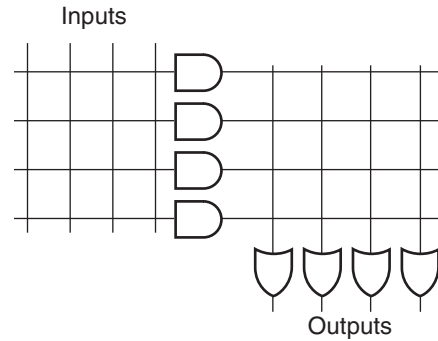

PAL Array

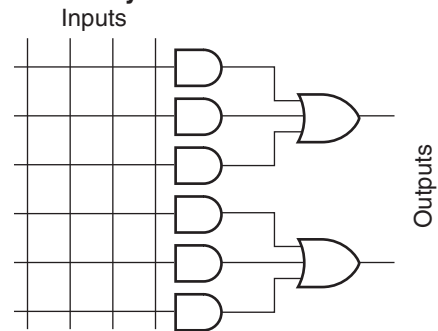

DS012_08_020601

Figure 2: PLA and PAL Array Example

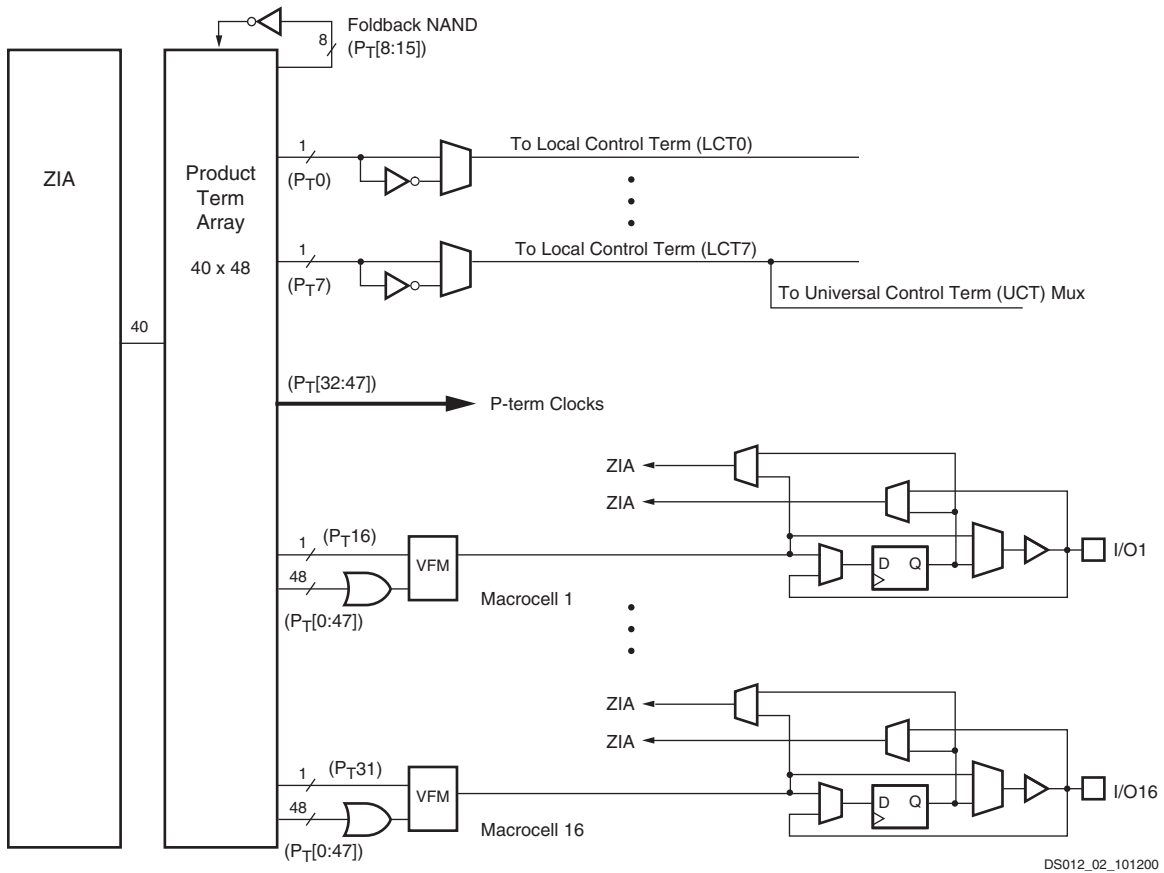

DS012_02_101200

Figure 3: Xilinx CoolRunner XPLA3 Function Block Architecture

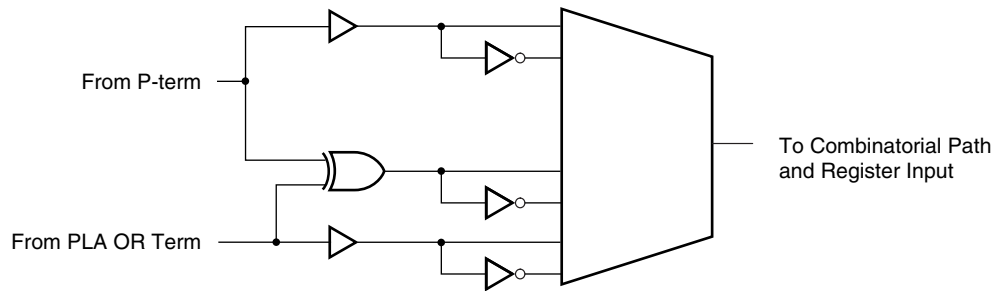

DS012_03_121699

Figure 4: Variable Function Multiplexer

Macrocell Architecture

Figure 5 shows the architecture of the macrocell used in the CoolRunner XPLA3 CPLD. Any macrocell can be reset or preset on power-up. Each macrocell register can be configured as a D-, T-, or Latch-type flip-flop, or bypassed if the macrocell is required as a combinatorial logic function.

Each of these flip-flops can be clocked from any one of eight sources or their complements. There are two global synchronous clocks that are selected from the four external clock pins. There is one universal clock signal. The clock input signals CT[4:7] (Local Control Terms) can be individu-

ally configured as either a PRODUCT term or SUM term equation created from the 40 signals available inside the function block.

There are two muxed paths to the ZIA. One mux selects from either the output of the VFM or the output of the register. The other mux selects from the output of the register or from the I/O pad of the macrocell. When the I/O pin is used as an output, the output buffer is enabled, and the macrocell feedback path can be used to feed back the logic implemented in the macrocell. When an I/O pin is used as an input, the output buffer is 3-stated and the input signal is fed into the ZIA via the I/O feedback path. The logic imple-

mented in the buried macrocell can be fed back to the ZIA via the macrocell feedback path.

If a macrocell pin is configured as a registered input, there is a direct path to the register to provide a fast input setup time. If the macrocell is configured as a latch, the register

clock input functions as the latch enable, with the latch transparent when this signal is High. The hardwired clock enable is non-functional when the macrocell is configured as a latch.

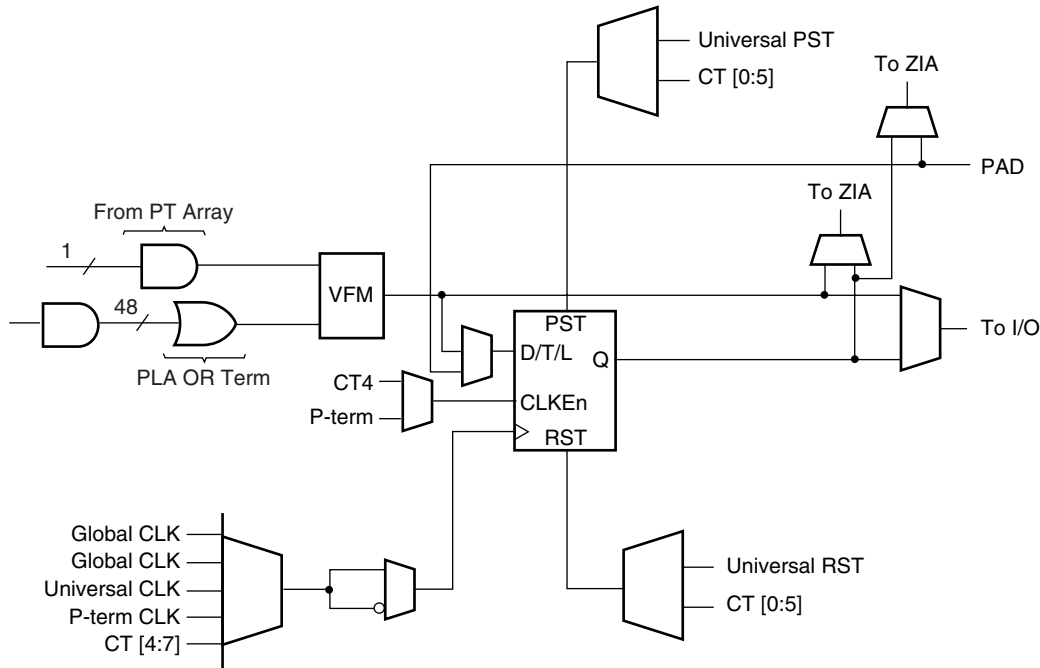

Note: Global CLK signals come from pins.

ds012_05_122299

Figure 5: XPLA3 Macrocell Architecture

I/O Cell

The OE (Output Enable) multiplexer has eight possible modes (Figure 6). When the I/O Cell is configured as an input (or 3-stated output), a half latch feature exists. This half latch pulls the input High (through a weak pull-up) if the input should float and cross the threshold. This protects the input from staying in the linear region and causing an increased amount of power consumption. This same weak pull-up can be enabled in software such that it is always on when the I/O Cell is configured as an input. This weak pull up is automatically turned on when a pin is unused by the design.

The I/O Cell is 5V tolerant when the device is powered. Each output has independent slew rate control (fast or slow) which assists in reducing EMI emissions.

See individual device data sheets for 3.3V PCI electrical specification compatibility.

Note that an I/O macrocell used as buried logic that does not have the I/O pin used for input is considered to be unused, and the weak pull-up resistors will be turned on. It is recommended that any unused I/O pins on the CoolRunner XPLA3 family of CPLDs be left unconnected. Dedicated

input pins (CLKx/INx) do not have on-chip weak pull-up resistors; therefore unused dedicated input pins must have external termination. As with all CMOS devices, do not allow inputs to float.

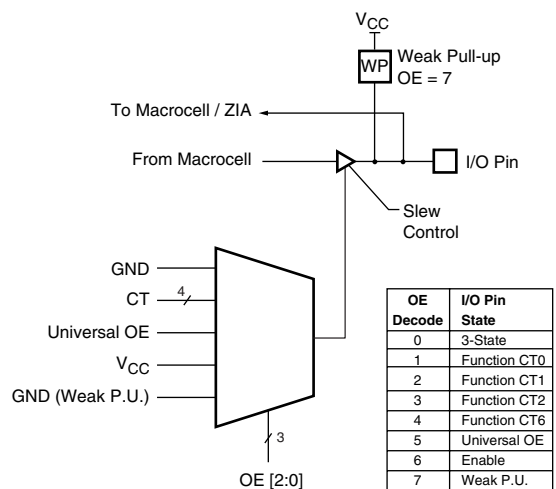

ds012_06_121699

Figure 6: I/O Cell

Power-Up Characteristics

During power-up, the CoolRunner XPLA3 device I/Os may be undefined until V_{CC} rises above 1.0V. This time period is called the Subthreshold State, as transistors have not yet fully been turned on. When V_{CC} rises above 1.0V, the device I/Os enter the Quiescent State, and I/Os are disabled with weak pull-ups as shown in Table 3. When V_{CC} reaches the threshold of the User Operation State (approximately 2.1V), user registers are initialized (typically within 200 μ s) after which I/Os assume the behavior determined by the user pattern, as shown in Figure 7.

If the device is in the erased state (before any user pattern is programmed), the device outputs remain disabled with weak pull-ups. The JTAG pins are enabled to allow the device to be programmed at any time. All devices are shipped in the erased state from the factory.

If the device is programmed, the device inputs and outputs take on their configured states for normal operation.

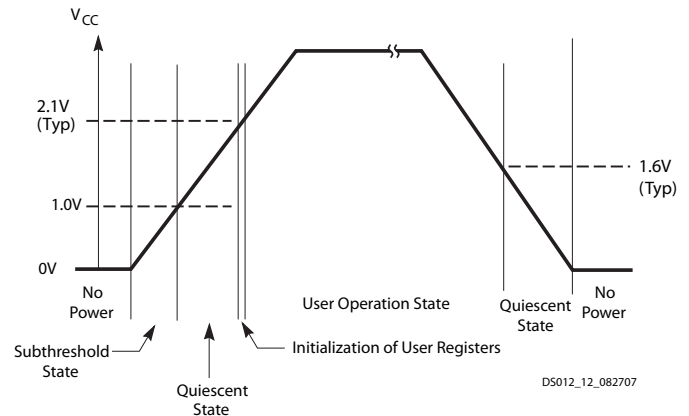

Figure 7: Device Behavior During Power Up

Table 3: I/O Power-Up Characteristics

Device Circuitry	Subthreshold State	Quiescent State	Erased Device Operation	Valid User Operation
Device I/Os	Undetermined	Disabled with Weak Pull-up	Disabled with Weak Pull-up	As Configured
Device Inputs/Clocks	Undetermined	High-Z	High-Z	High-Z
JTAG Controller	Undetermined	Disabled with Weak Pull-up	Enabled	As Configured

Security

Designs can be secured during programming to prevent pattern theft via readback. This security setting does not protect readback of the Usercode/signature space, which is

often used for storing application serial numbers or revision codes. The only way to clear the security setting is to completely erase the entire device.

Timing Model

The CoolRunner XPLA3 architecture follows a timing model that allows deterministic timing in design and redesign. The basic timing model is shown in Figure 8. There is a fast path (T_{LOG1}) into the macrocell which is used if there is a single product term. The T_{LOG2} path is used for multiple product term timing. For optimization of logic, the CoolRunner XPLA3 CPLD architecture includes a Foldback NAND path

(T_{LOG3}). There is a fast input path to each macrocell if used as an Input Register (T_{FIN}). The CoolRunner XPLA3 architecture also includes universal control terms (T_{UDA}) that can be used for synchronization of the macrocell registers in different function blocks. There is slew rate control and output enable control on a per macrocell basis.

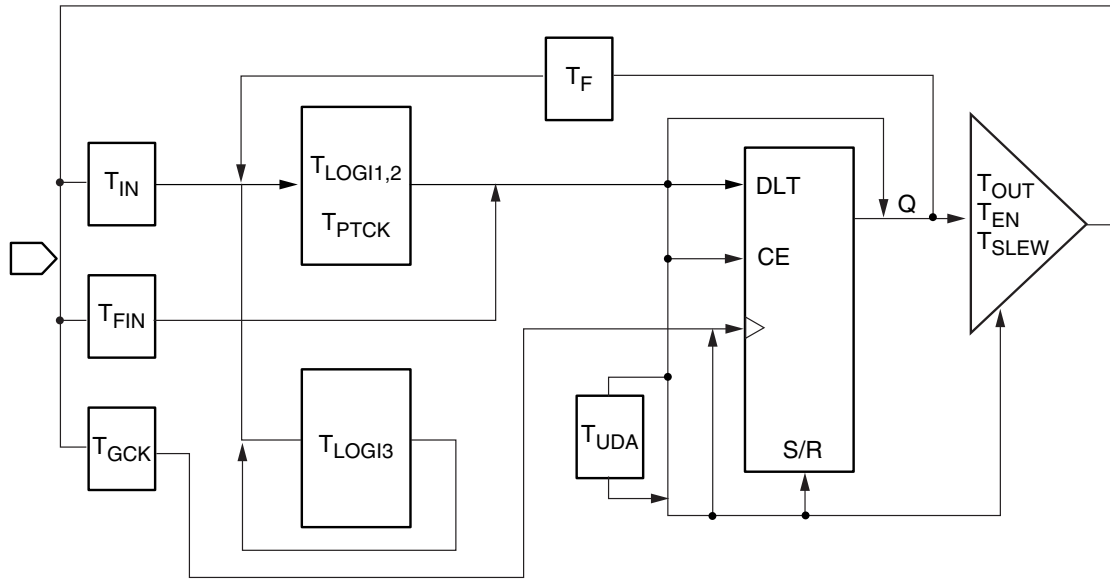

DS017_02_031802

Figure 8: XPLA3 Timing Model

JTAG Testing Capability

JTAG is the commonly used acronym for the Boundary Scan Test (BST) feature defined for integrated circuits by IEEE Standard 1149.1. This standard defines input/output pins, logic control functions, and commands that facilitate both board and device level testing without the use of specialized test equipment. CoolRunner XPLA3 devices use the JTAG Interface for In-System Programming/Reprogramming. The JTAG command set is implemented as described in Table 4.

As implemented in CoolRunner XPLA3 CPLDs, the JTAG Port includes four of the five pins (refer to Table 5) described in the JTAG specification: TCK, TMS, TDI, and TDO. The fifth signal defined by the JTAG specification is TRST (Test Reset). TRST is considered an optional signal, since it is not actually required to perform BST or ISP. The CoolRunner XPLA3 CPLD saves an I/O pin for general purpose use by not implementing the optional TRST signal in the JTAG interface. Instead, the CoolRunner XPLA3 CPLD supports the test reset functionality through the use of its power-up reset circuit.

Port Enable Pin

The Port Enable pin is used to reclaim TMS, TDO, TDI, and TCK for JTAG ISP programming if the user has defined

these pins as general purpose I/O during device programming. For ease of use, CoolRunner XPLA3 devices are shipped with the JTAG port pins enabled. The Port Enable pin must be a low logic level during the power-up sequence for the device to operate properly.

During device programming, the JTAG ISP pins can be left as is or reconfigured as user specific I/O pins. If the JTAG ISP pins have been used for I/O pins, simply applying a high logic level to the Port Enable pin converts the JTAG ISP pins back to their respective programming function and the device can be reprogrammed via ISP. After completing the desired JTAG ISP programming function, simply return Port Enable to Ground to re-establish the JTAG ISP pins to their respective I/O function. Reconfiguring the JTAG port pins as I/Os makes these pins non-JTAG ISP functional until reclaimed by port enable.

If the JTAG pins are not required as I/O, port enable should be permanently tied to GND. Pins associated with the JTAG port have internal weak pull ups enabled to terminate the pins. However, in noisy environments, external 10K pull ups are recommended.

The CoolRunner XPLA3 family allows the macrocells associated with these pins to be used as buried logic when the JTAG/ISP function is enabled.

Table 4: XPLA3 Low-level JTAG Boundary-scan Commands

Instruction (Instruction Code) Register Used	Description
Sample/Preload (00010) Boundary-scan Register	The mandatory Sample/Preload instruction allows a snapshot of the normal operation of the component to be taken and examined. It also allows data values to be loaded into the latched parallel outputs of the Boundary-scan Shift Register prior to selection of the other boundary-scan test instructions.
Extest (00000) Boundary-scan Register	The mandatory Extest instruction allows testing of off-chip circuitry and board level interconnections. Data is typically loaded onto the latched parallel outputs of Boundary-scan Shift Register using the Sample/Preload instruction prior to selection of the Extest instruction.
Bypass (11111) Bypass Register	Places the 1-bit bypass register between the TDI and TDO pins, which allows the BST data to pass synchronously through the selected device to adjacent devices during normal device operation. The Bypass instruction can be entered by holding TDI at a constant High value and completing an Instruction-scan cycle.
Idcode (00001) Boundary-scan Register	Selects the Idcode register and places it between TDI and TDO, allowing the Idcode to be serially shifted out of TDO. The Idcode instruction permits blind interrogation of the components assembled onto a printed circuit board. Thus, in circumstances where the component population can vary, it is possible to determine what components exist in a product.
High-Z (00101) Bypass Register	The High-Z instruction places the component in a state which all of its system logic outputs are placed in an inactive drive state (e.g., high impedance). In this state, an in-circuit test system can drive signals onto the connections normally driven by a component output without incurring the risk of damage to the component. The High-Z instruction also forces the Bypass Register between TDI and TDO.
Intest (00011) Boundary-scan Register	The Intest instruction selects the boundary scan register prior to applying tests to the logic core of the device. This permits testing of on-chip system logic while the component is already on the board.

Table 5: JTAG Pin Description

Pin	Name	Description
TCK	Test Clock Input	Clock pin to shift the serial data and instructions in and out of the TDI and TDO pins, respectively.
TMS	Test Mode Select	Serial input pin selects the JTAG instruction mode. TMS should be driven High during user mode operation.
TDI	Test Data Input	Serial input pin for instructions and test data. Data is shifted in on the rising edge of TCK.
TDO	Test Data Output	Serial output pin for instructions and test data. Data is shifted out on the falling edge of TCK. The signal is 3-stated if data is not being shifted out of the device.

3V, In-System Programming (ISP)

CoolRunner XPLA3 CPLDs allow for 3V, in-system programming/reprogramming of its EEPROM cells via a JTAG interface. An on-chip charge pump eliminates the need for externally provided super-voltages. This allows program-

ming on the circuit board using only the 3V supply required by the device for normal operation. The ISP commands implemented in CoolRunner XPLA3 CPLDs are specified in [Table 6](#).

Table 6: Low-level ISP Commands

Instruction (Register Used)	Instruction Code	Description
Enable (ISP Shift Register)	01001	Enables the Erase, Program, and Verify commands. Using the Enable instruction before the Erase, Program, and Verify instructions allows the user to specify the outputs of the device using the JTAG Boundary-Scan Sample/Preload command.
Erase (ISP Shift Register)	01010	Erases the entire EEPROM array. User can define the outputs during this operation by using the JTAG Sample/Preload command.
Program (ISP Shift Register)	01011	Programs the data in the ISP Shift Register into the addressed EEPROM row. The outputs can be defined by using the JTAG Sample/Preload command.
Disable (ISP Shift Register)	10000	Allows the user to leave ISP mode. It selects the ISP register to be directly connected between TDO and TDI.
Verify (ISP Shift Register)	01100	Transfers the data from the addressed row to the ISP Shift Register. The data can then be shifted out and compared with the JEDEC file. The user can define the outputs during this operation.

JTAG and ISP Interfacing

A number of industry-established methods exist for JTAG/ISP interfacing with CPLDs and other integrated circuits. The CoolRunner XPLA3 family supports the following methods:

- Xilinx HW 130

- PC Parallel Port
- Workstation or PC Serial Port
- Embedded Processor
- Automated Test Equipment
- Third Party Programmers
- Xilinx ISP Programming Tools

Table 7: Programming Specifications

Symbol	Parameter	Min.	Max.	Unit
DC Parameters				
V _{CCP}	V _{CC} supply program/verify	3.0	3.6	V
I _{CCP}	I _{CC} limit program/verify ⁽¹⁾	-	30	mA
V _{IH}	Input voltage (High)	2.0	-	V
V _{IL}	Input voltage (Low)	-	0.8	V
V _{OL}	Output voltage (Low)	-	0.4	V
V _{OH}	Output voltage (High)	2.4	-	V
AC Parameters				
F _{MAX}	TCK maximum frequency	-	10	MHz
P _{WE}	Pulse width erase	100	-	ms
P _{WP}	Pulse width program	10	-	ms
P _{WV}	Pulse width verify	10	-	μs
T _{INIT}	Initialization time ⁽¹⁾	-	200	μs
T _{MS_SU}	TMS setup time before TCK ↑	10	-	ns
T _{DI_SU}	TDI setup time before TCK ↑	10	-	ns
T _{MS_H}	TMS hold time after TCK ↑	20	-	ns
T _{DI_H}	TDI hold time after TCK ↑	20	-	ns
T _{DO_CO}	TDO valid after TCK ↓	-	30	ns

Notes:

1. Family specification. See individual device data sheets for specific device measurements.

Absolute Maximum Ratings

Symbol	Parameter ⁽¹⁾	Min.	Max.	Unit
V _{CC}	Supply voltage ⁽²⁾ relative to GND	-0.5	4.0	V
V _I	Input voltage ⁽³⁾ relative to GND	-0.5	5.5 ⁽⁴⁾	V
I _{OUT}	Output current, per pin	-100	100	mA
T _J	Maximum junction temperature	-40	150	°C
T _{STR}	Storage temperature	-65	150	°C

Notes:

1. Stresses above those listed might cause malfunction or permanent damage to the device. This is a stress rating only. Functional operation at these or any other condition above those indicated in the operational and programming specification is not implied.
2. The chip supply voltage must rise monotonically.
3. Maximum DC undershoot below GND must be limited to either 0.5V or 10 mA, whichever is easier to achieve. During transitions, the device pins can undershoot to -2.0V or overshoot to 7.0V, provided this over- or undershoot lasts less than 10 ns and with the forcing current being limited to 200 mA.
4. External I/O voltage must not exceed V_{CC} by 4.0V.

Recommended Operation Conditions

Symbol	Parameter	Test Conditions	Min.	Max.	Unit
V _{CC}	Supply voltage	Commercial T _A = 0°C to 70°C	3.0	3.6	V
		Industrial T _A = -40°C to +85°C	2.7	3.6	V
V _{IL}	Low-level input voltage		0	0.8	V
V _{IH}	High-level input voltage		2.0	5.5	V
V _O	Output voltage		0	V _{CC}	V
T _R	Input rise time		-	20	ns
T _F	Input fall time		-	20	ns

Quality and Reliability Characteristics

Symbol	Parameter	Min	Max	Units
T _{DR}	Data retention	20	-	Years
N _{PE}	Program/erase cycles (Endurance) MOSIV devices	1,000	-	Cycles
N _{PE}	Program/erase cycles (Endurance) UMC devices	10,000	-	Cycles
V _{ESD}	Electrostatic Discharge (ESD)	2,000	-	Volts

Additional Information

[CoolRunner XPLA3 CPLD Data Sheets and Application Notes](#)

[Device Packages](#)

[Device Package User Guide](#)

Revision History

The following table shows the revision history for this document.

Date	Version	Revision
02/20/00	1.0	Initial Xilinx release.
03/06/00	1.1	Minor updates.
11/30/00	1.2	Updated Macrocell numbering, I/O pins, and available packages.
02/09/01	1.3	Updated specification.
04/11/01	1.4	Under Features, changed Global 3-state to Universal 3-state. Added XCR3512XL device; changed T_{SU} numbers, added 324-pin FINELINE BGA package, Programming Specs: changed T_{INIT} from 50 min. to 50 max., Quality & Rel. specs: added N_{PE} for UMC devices—10,000 cycles.
01/07/02	1.5	Table 7: Added Note 1, changed T_{INIT} from 50 to 200 (max). Changed I_{CCP} from 20 to 30 (max); updated Device Family Table 1 usable gate counts. Updated Device Family Table 2 package types, updated I/O cell section. Absolute Maximum Ratings table: Changed max supply voltage relative to GND to 4.0V to match XC9500XL and UMC standard specs.
01/06/03	1.6	Added T_{PTCK} parameter to timing model. Changed F_{SYSTEM} for all devices in Table 1 . Changed from Advance Information to Preliminary. Added Note 1 to Figure 2 regarding XCR3384XL TQ144 JTAG pins.
06/23/03	1.7	Added Power-Up Characteristics .
02/13/04	1.8	Added Maximum Soldering temperature (T_{SOL}) specification. Added links.
09/29/04	1.9	Added text on shadow memory to first paragraph, page 2.
01/10/05	2.0	Changed Function Block input references to 40.
04/08/05	2.1	Add I_{CCSB} Typical Specification
03/31/06	2.2	Added Warranty Disclaimer.
08/31/07	2.3	Added description of subthreshold power-up characteristics, page 6. Changes to Figure 7 and Table 3 on page 6 to describe subthreshold behavior. Add security description, page 6.
09/08/08	2.4	Removed PC44 and PCG44 packages. See Product Discontinuation Notice xcn07022.pdf .
05/26/09	2.5	Added note 3 to Table 2 .

Notice of Disclaimer

THE XILINX HARDWARE FPGA AND CPLD DEVICES REFERRED TO HEREIN (“PRODUCTS”) ARE SUBJECT TO THE TERMS AND CONDITIONS OF THE XILINX LIMITED WARRANTY WHICH CAN BE VIEWED AT <http://www.xilinx.com/warranty.htm>. THIS LIMITED WARRANTY DOES NOT EXTEND TO ANY USE OF PRODUCTS IN AN APPLICATION OR ENVIRONMENT THAT IS NOT WITHIN THE SPECIFICATIONS STATED IN THE XILINX DATA SHEET. ALL SPECIFICATIONS ARE SUBJECT TO CHANGE WITHOUT NOTICE. PRODUCTS ARE NOT DESIGNED OR INTENDED TO BE FAIL-SAFE OR FOR USE IN ANY APPLICATION REQUIRING FAIL-SAFE PERFORMANCE, SUCH AS LIFE-SUPPORT OR SAFETY DEVICES OR SYSTEMS, OR ANY OTHER APPLICATION THAT INVOKES THE POTENTIAL RISKS OF DEATH, PERSONAL INJURY, OR PROPERTY OR ENVIRONMENTAL DAMAGE (“CRITICAL APPLICATIONS”). USE OF PRODUCTS IN CRITICAL APPLICATIONS IS AT THE SOLE RISK OF CUSTOMER, SUBJECT TO APPLICABLE LAWS AND REGULATIONS.