

RoHS  **233 Series, 5 x 20 mm, Medium-Acting Fuse**

Description

5x20mm medium-acting glass body fuse designed to UL specification.





Features

- Designed to UL/CSA/ ANCE 248 Standard
- Available in cartridge and axial lead format
- RoHS compliant and lead-free

Applications

Used as supplementary protection in appliance or utilization equipment to provide individual protection for components or internal circuits.





Agency Approvals

Agency	Agency File Number	Ampere Range
	Cartridge Certificates: NBK280602-E10480 C NBK290502-E10480 I	1A – 5A 6A – 10A
	Leaded Certificates: NBK280602-E10480 D NBK290502-E10480 J	1A – 5A 6A – 10A
	Certificates: SU05001 – 2010	1A – 6.5A
	Listed File: E10480 Guide: JDYX	1A – 10A
	File: 029862 Acc. Class: LR1422-01	
		
		

Electrical Characteristics for Series

% of Ampere Rating	Ampere Rating	Opening Time
100%	1A – 3.5A	4 hours, Minimum
	4A – 7A	1 hour, Minimum
	8A – 10A	1 hour, Minimum
135%	1A – 3.5A	15 sec., Min; 1500 sec., Max.
	4A – 7A	15 sec., Min; 1500 sec., Max.
	8A – 10A	3 sec., Min; 3600 sec., Max.
200%	1A – 3.5A	.60 sec., Min; 3 sec., Max.
	4A – 7A	.60 sec., Min; 3 sec., Max.
	8A – 10A	0.4 sec., Min; 2.25 sec., Max.

Electrical Characteristic Specifications by Item

Amp Code	Amp Rating (A)	Voltage Rating (V)	Interrupting Rating	Nominal Cold Resistance (Ohms)	Nominal Melting I ² t (A ² sec)	Agency Approvals				
										
001.	1	125	10,000A @ 125 VAC	0.1750	1.97500	x	x	x	x	x
1.25	1.25	125		0.1263	3.39000	x	x	x	x	x
01.6	1.6	125		0.0880	6.14000	x	x	x	x	x
002.	2	125		0.0684	9.97000	x	x	x	x	x
02.5	2.5	125		0.0521	17.04500	x	x	x	x	x
003.	3	125		0.0431	26.24000	x	x	x	x	x
3.15	3.15	125		0.0380	29.79500	x	x	x	x	x
03.5	3.5	125		0.0322	36.27500	x	x	x	x	x
004.	4	125		0.0293	51.61000	x	x	x	x	x
005.	5	125		0.0217	89.97500	x	x	x	x	x
006.	6	125		0.0179	131.45500	x	x	x	x	x
06.3	6.3	125		0.0166	151.90500	x	x	x	x	x
007.	7	125		0.0137	157.31000	x	x		x	
008.	8	125		0.0084	169.43500	x	x	x	x	
010.	10	125		0.0066	274.11500	x	x	x	x	

Temperature Derating Curve

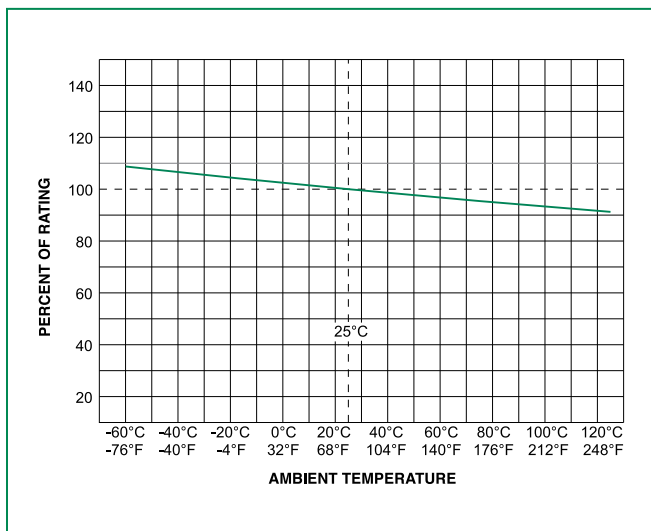

Average Time Current Curves

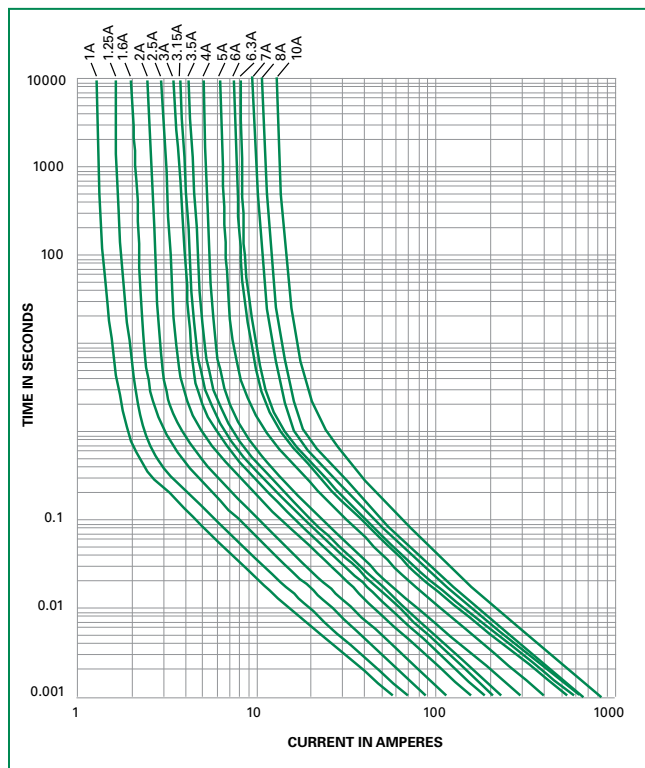

Soldering Parameters - Wave Soldering

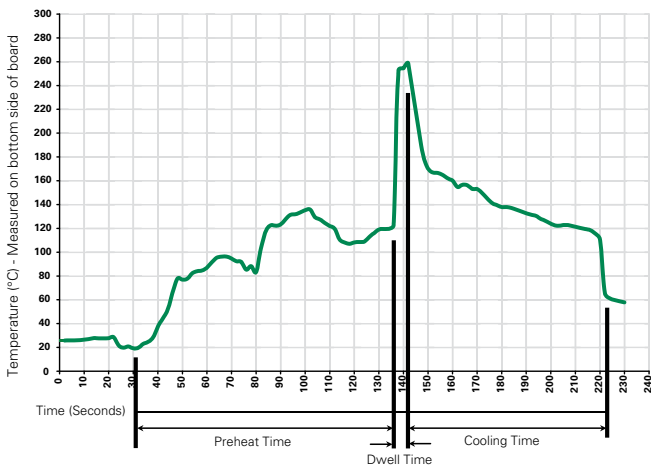

Recommended Process Parameters:

Wave Parameter	Lead-Free Recommendation
Preheat: (Depends on Flux Activation Temperature)	(Typical Industry Recommendation)
Temperature Minimum:	100° C
Temperature Maximum:	150° C
Preheat Time:	60-180 seconds
Solder Pot Temperature:	260° C Maximum
Solder Dwell Time:	2-5 seconds

Recommended Hand-Solder Parameters:

Solder Iron Temperature: 350° C +/- 5° C
Heating Time: 5 seconds max.

Note: These devices are not recommended for IR or Convection Reflow process.

Product Characteristics

Materials	Body: Glass Cap: Nickel-plated brass Leads: Tin-plated Copper
Terminal Strength	MIL-STD-202G, Method 211A, Test Condition A
Solderability	Reference IEC 60127 Second Edition 2003-01 Annex A
Product Marking	Cap 1: Brand logo, current and voltage rating Cap 2: Series and agency approval markings
Packaging	Available in Bulk (M=1000 pcs/pkg) or on Tape/Reel (MRET1=1000 pcs/reel)

Operating Temperature	-55°C to +125°C
Thermal Shock	MIL-STD-202G, Method 107G, Test Condition B: (5 cycles -65°C to +125°C)
Vibration	MIL-STD-202G, Method 201A
Humidity	MIL-STD-202G, Method 103B, Test Condition A. high RH (95%) and elevated temp (40°C) for 240 hours
Salt Spray	MIL-STD-202G, Method 101D, Test Condition B

Dimensions

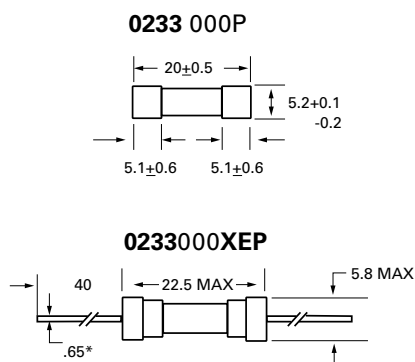

All dimensions in mm

Notes:

* Ratings above 6.3A have 0.8 mm dia lead

Part Numbering System

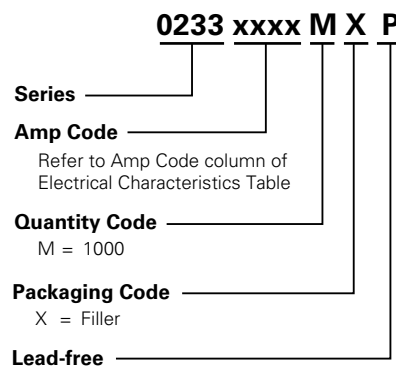

Packaging

Packaging Option	Packaging Specification	Quantity	Quantity & Packaging Code	Taping Width
233 Series				
Bulk	N/A	1000	MX	N/A
Bulk	N/A	1000	MXE	N/A
Reel and Tape	EIA 296-E	1000	MRET1	T1=52mm (2.062")