



GQM2195C2E1R0BB12#

" # " indicates a package specification code.

Recommended   Complies with RoHS 

< List of part numbers with package codes >
 GQM2195C2E1R0BB12D , GQM2195C2E1R0BB12B

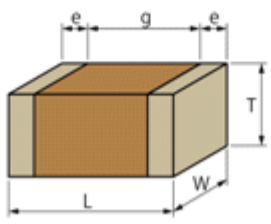
Shape

 	
L size	2.0 ± 0.15mm
W size	1.25 ± 0.15mm
T size	0.85 ± 0.15mm
External terminal width e	0.2 to 0.7mm
Distance between external terminals g (Min.)	0.7mm
Size code in mm(inch)	2012 (0805)

References

Packaging	Specifications	Minimum quantity
D	Paper tape (180mm)	4000
B	Packing in bulk	1000

Mass (typ.)	
1 piece	9.5mg
Reel (180mm)	142g

Specifications

Capacitance	1.0pF ± 0.1pF
Rated voltage	250Vdc
Temperature characteristics (complied standard)	COG(EIA)
Temperature coefficient	0 ± 30ppm/
Temperature range of temperature characteristics	25 to 125
Operating temperature range	-55 to 125

Attention

- 1.This datasheet is downloaded from the website of Murata Manufacturing Co., Ltd. Therefore, it ' s specifications are subject to change or our products in it may be discontinued without advance notice. Please check with our sales representatives or product engineers before ordering.
- 2.This datasheet has only typical specifications because there is no space for detailed specifications. Therefore, please review our product specifications or consult the approval sheet for product specifications before ordering.

▪ Frequency characteristics (ESR, Impedance)

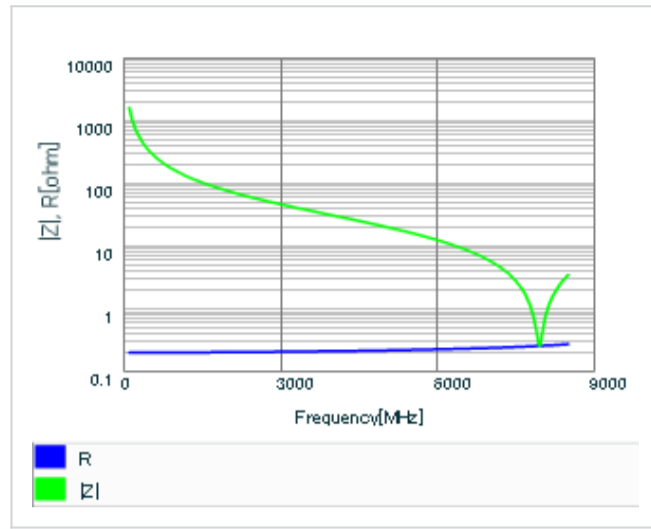

▪ S parameter (Smith chart S11)

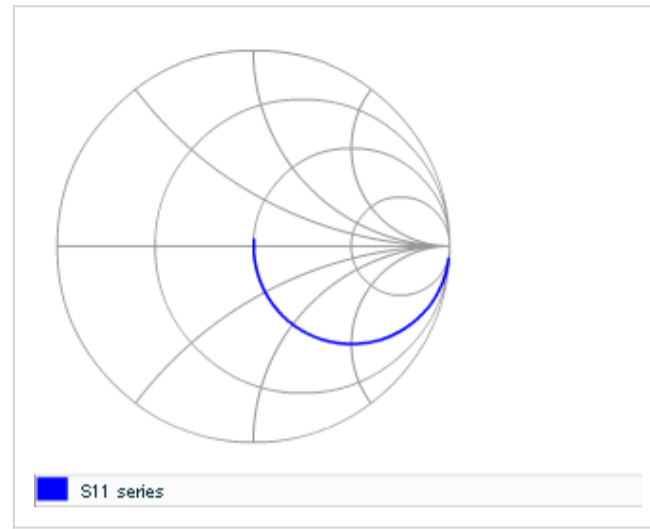

▪ DC bias characteristics

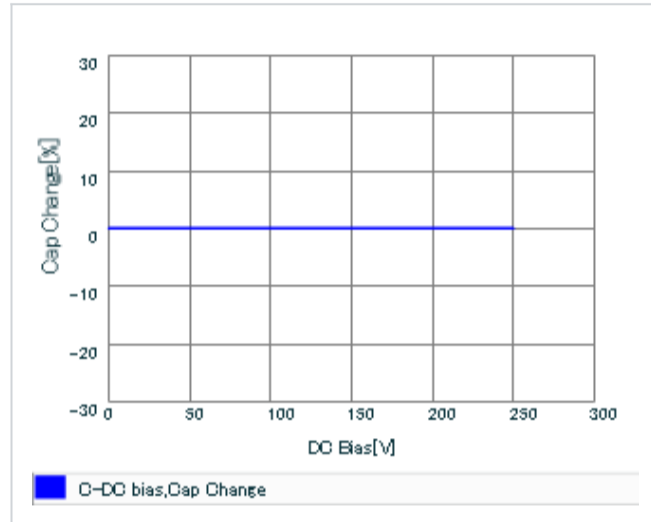

▪ AC voltage characteristics

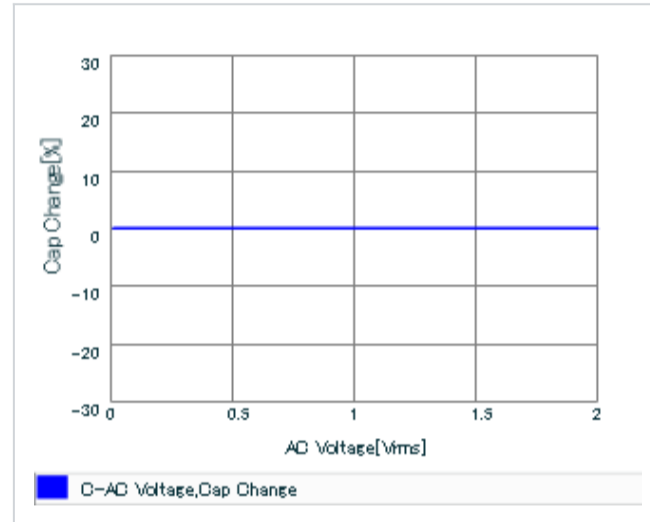

▪ Capacitance - temperature characteristics

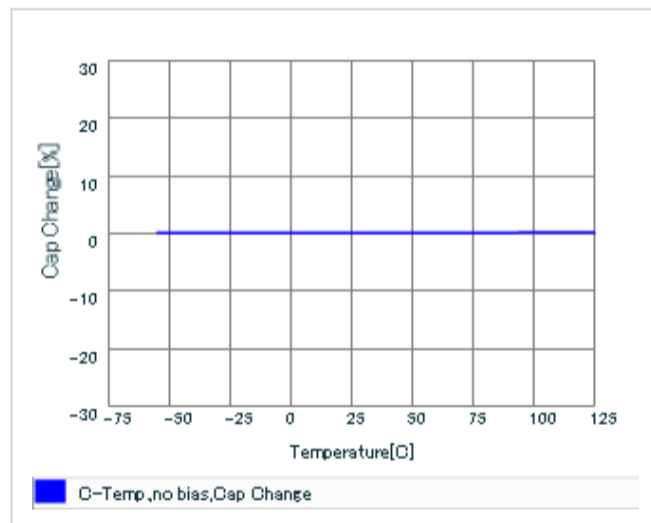

▪ Calorific property by ripple current

