

Optocoupler, Phototransistor Output (Dual, Quad Channel)

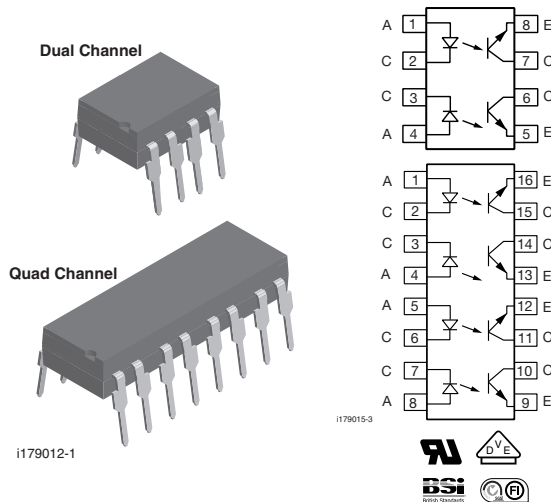

FEATURES

- Current transfer ratio at $I_F = 10 \text{ mA}$
- Isolation test voltage, $5300 V_{RMS}$
- Compliant to RoHS Directive 2002/95/EC and in accordance to WEEE 2002/96/EC



RoHS
COMPLIANT

AGENCY APPROVALS

- UL1577, file no. E52744 system code H or J, double protection
- CSA 93751
- BSI IEC 60950; IEC 60065
- DIN EN 60747-5-2 (VDE 0884) available with option 1
- FIMKO

DESCRIPTION

The ILD1, ILD2, ILD5, ILQ1, ILQ2, ILQ5 are optically coupled isolated pairs employing GaAs infrared LEDs and silicon NPN phototransistor. Signal information, including a DC level, can be transmitted by the drive while maintaining a high degree of electrical isolation between input and output. The ILD1, ILD2, ILD5, ILQ1, ILQ2, ILQ5 are especially designed for driving medium-speed logic and can be used to eliminate troublesome ground loop and noise problems. Also these couplers can be used to replace relays and transformers in many digital interface applications such as CTR modulation.

The ILD1, ILD2, ILD5 has two isolated channels in a single DIP package and the ILQ1, ILQ2, ILQ5 has four isolated channels per package.

ORDERING INFORMATION

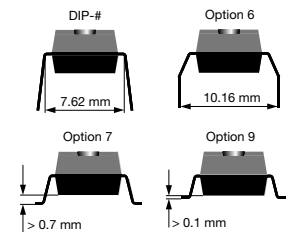
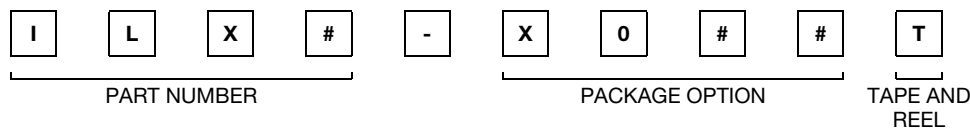

AGENCY CERTIFIED/PACKAGE	CTR (%)		
	20	50	100
UL, CUL, BSI, FIMKO	20	50	100
DIP-16	ILD1	ILD5	ILD2
DIP-16, 400 mil, option 6	ILQ1-X006	-	ILQ2-X006
SMD-16, option 7	ILQ1-X007	-	ILQ2-X007T ⁽¹⁾
SMD-16, option 9	ILQ1-X009	ILQ5-X009T ⁽¹⁾	ILQ2-X009T ⁽¹⁾
DIP-8	ILD1	ILD5	ILD2
DIP-8, 400 mil, option 6	-	-	ILD2-X006
SMD-8, option 7	ILD1-X007T ⁽¹⁾	-	ILD2-X007T ⁽¹⁾
SMD-8, option 9	ILD1-X009T ⁽¹⁾	ILD5-X009T ⁽¹⁾	ILD2-X009T ⁽¹⁾

ILD1, ILD2, ILD5, ILQ1, ILQ2, ILQ5



Vishay Semiconductors Optocoupler, Phototransistor Output
(Dual, Quad Channel)

AGENCY CERTIFIED/PACKAGE VDE, UL, CUL, BSI,	CTR (%)		
	20	50	100
DIP-16	-	-	ILQ2-X001
DIP-16, 400 mil, option 6	-	-	ILQ2-X016
SMD-16, option 7	-	-	ILQ2-X017T ⁽¹⁾
DIP-8	ILD1-X001	ILD5-X001	ILD2-X001
DIP-8, 400 mil, option 6	-	-	ILD2-X016
SMD-8, option 7	-	-	ILD2-X017
SMD-8, option 9	ILD1-X019T	-	-

Note

⁽¹⁾ Also available in tubes; do not put T on end.

ABSOLUTE MAXIMUM RATINGS ⁽¹⁾ (T _{amb} = 25 °C, unless otherwise specified)					
PARAMETER	TEST CONDITION	PART	SYMBOL	VALUE	UNIT
INPUT					
Reverse voltage			V _R	6	V
Forward current			I _F	60	mA
Surge current			I _{FSM}	2.5	A
Power dissipation			P _{diss}	100	mW
Derate linearly from 25 °C				1.3	mW/°C
OUTPUT					
Collector emitter reverse voltage		ILD1	V _{CEO}	50	V
		ILQ1	V _{CEO}	50	V
		ILD2	V _{CEO}	70	V
		ILQ2	V _{CEO}	70	V
		ILD5	V _{CEO}	70	V
		ILQ5	V _{CEO}	70	V
Collector current	t < 1 ms		I _C	50	mA
			I _C	400	mA
Power dissipation			P _{diss}	200	mW
Derate linearly from 25 °C				2.6	mW/°C
COUPLER					
Isolation test voltage between emitter and detector			V _{ISO}	5300	V _{RMS}
Creepage distance				≥ 7	mm
Clearance distance				≥ 7	mm
Isolation resistance	V _{IO} = 500 V, T _{amb} = 25 °C		R _{IO}	10 ¹²	Ω
	V _{IO} = 500 V, T _{amb} = 100 °C		R _{IO}	10 ¹¹	
Package power dissipation			P _{tot}	250	mW
Derate linearly from 25 °C				3.3	mW/°C
Storage temperature			T _{stg}	- 40 to + 150	°C
Operating temperature			T _{amb}	- 40 to + 100	°C
Junction temperature			T _j	100	°C
Soldering temperature ⁽²⁾	2 mm from case bottom		T _{slid}	260	°C

Notes

⁽¹⁾ Stresses in excess of the absolute maximum ratings can cause permanent damage to the device. Functional operation of the device is not implied at these or any other conditions in excess of those given in the operational sections of this document. Exposure to absolute maximum ratings for extended periods of the time can adversely affect reliability.

⁽²⁾ Refer to reflow profile for soldering conditions for surface mounted devices (SMD). Refer to wave profile for soldering conditions for through hole devices (DIP).



ILD1, ILD2, ILD5, ILQ1, ILQ2, ILQ5

Optocoupler, Phototransistor Output Vishay Semiconductors
(Dual, Quad Channel)

ELECTRICAL CHARACTERISTICS ($T_{amb} = 25\text{ }^{\circ}\text{C}$, unless otherwise specified)						
PARAMETER	TEST CONDITION	SYMBOL	MIN.	TYP.	MAX.	UNIT
INPUT						
Forward voltage	$I_F = 60\text{ mA}$	V_F		1.25	1.65	V
Reverse current	$V_R = 6\text{ V}$	I_R		0.01	10	μA
Capacitance	$V_R = 0\text{ V}$, $f = 1\text{ MHz}$	C_O		25		pF
Thermal resistance, junction to lead		T_{thJL}		750		K/W
OUTPUT						
Collector emitter capacitance	$V_{CE} = 5\text{ V}$, $f = 1\text{ MHz}$	C_{CE}		6.8		pF
Collector emitter leakage current	$V_{VCE} = 10\text{ V}$	I_{CEO}		5	50	nA
Saturation voltage, collector emitter	$I_C = 1\text{ mA}$, $I_B = 20\text{ }\mu\text{A}$	V_{CESAT}		0.25	0.4	V
DC forward current gain	$V_{CE} = 10\text{ V}$, $I_B = 20\text{ }\mu\text{A}$	h_{FE}	200	650	1800	
DC forward current gain saturated	$V_{CE} = 0.4\text{ V}$, $I_B = 20\text{ }\mu\text{A}$	h_{FEsat}	120	400	600	
Thermal resistance, junction to lead		R_{thjl}		500		K/W
COUPLER						
Capacitance (input to output)	$V_{IO} = 0\text{ V}$, $f = 1\text{ MHz}$	C_{IO}		0.8		pF

Note

- Minimum and maximum values are testing requirements. Typical values are characteristics of the device and are the result of engineering evaluation. Typical values are for information only and are not part of the testing requirements.

CURRENT TRANSFER RATIO							
PARAMETER	TEST CONDITION	PART	SYMBOL	MIN.	TYP.	MAX.	UNIT
I_C/I_F (collector emitter saturated)	$I_F = 10\text{ mA}$, $V_{CE} = 0.4\text{ V}$	ILD1	CTR_{CEsat}		75		%
		ILQ1	CTR_{CEsat}		75		%
		ILD2	CTR_{CEsat}		170		%
		ILQ2	CTR_{CEsat}		170		%
		ILD5	CTR_{CEsat}		100		%
		ILQ5	CTR_{CEsat}		100		%
	$I_F = 10\text{ mA}$, $V_{CE} = 10\text{ V}$	ILD1	CTR_{CE}	20	80	300	%
		ILQ1	CTR_{CE}	20	80	300	%
		ILD2	CTR_{CE}	100	200	500	%
		ILQ2	CTR_{CE}	100	200	500	%
		ILD5	CTR_{CE}	50	130	400	%
		ILQ5	CTR_{CE}	50	130	400	%

ILD1, ILD2, ILD5, ILQ1, ILQ2, ILQ5



Vishay Semiconductors Optocoupler, Phototransistor Output
(Dual, Quad Channel)

SWITCHING CHARACTERISTICS							
PARAMETER	TEST CONDITION	PART	SYMBOL	MIN.	TYP.	MAX.	UNIT
NON-SATURATED							
Current	$V_{CE} = 5\text{ V}, R_L = 75\ \Omega, 50\% \text{ of } V_{PP}$	ILD1	I_F		20		mA
		ILQ1	I_F		20		mA
		ILD2	I_F		5		mA
		ILQ2	I_F		5		mA
		ILD5	I_F		10		mA
		ILQ5	I_F		10		mA
Delay	$V_{CE} = 5\text{ V}, R_L = 75\ \Omega, 50\% \text{ of } V_{PP}$	ILD1	t_D		0.8		μs
		ILQ1	t_D		0.8		μs
		ILD2	t_D		1.7		μs
		ILQ2	t_D		1.7		μs
		ILD5	t_D		1.7		μs
		ILQ5	t_D		1.7		μs
Rise time	$V_{CE} = 5\text{ V}, R_L = 75\ \Omega, 50\% \text{ of } V_{PP}$	ILD1	t_r		1.9		μs
		ILQ1	t_r		1.9		μs
		ILD2	t_r		2.6		μs
		ILQ2	t_r		2.6		μs
		ILD5	t_r		2.6		μs
		ILQ5	t_r		2.6		μs
Storage	$V_{CE} = 5\text{ V}, R_L = 75\ \Omega, 50\% \text{ of } V_{PP}$	ILD1	t_s		0.2		μs
		ILQ1	t_s		0.2		μs
		ILD2	t_s		0.4		μs
		ILQ2	t_s		0.4		μs
		ILD5	t_s		0.4		μs
		ILQ5	t_s		0.4		μs
NON-SATURATED							
Fall time	$V_{CE} = 5\text{ V}, R_L = 75\ \Omega, 50\% \text{ of } V_{PP}$	ILD1	t_f		1.4		μs
		ILQ1	t_f		1.4		μs
		ILD2	t_f		2.2		μs
		ILQ2	t_f		2.2		μs
		ILD5	t_f		2.2		μs
		ILQ5	t_f		2.2		μs
Propagation H to L	$V_{CE} = 5\text{ V}, R_L = 75\ \Omega, 50\% \text{ of } V_{PP}$	ILD1	t_{PHL}		0.7		μs
		ILQ1	t_{PHL}		0.7		μs
		ILD2	t_{PHL}		1.2		μs
		ILQ2	t_{PHL}		1.2		μs
		ILD5	t_{PHL}		1.1		μs
		ILQ5	t_{PHL}		1.1		μs
Propagation L to H	$V_{CE} = 5\text{ V}, R_L = 75\ \Omega, 50\% \text{ of } V_{PP}$	ILD1	t_{PLH}		1.4		μs
		ILQ1	t_{PLH}		1.4		μs
		ILD2	t_{PLH}		2.3		μs
		ILQ2	t_{PLH}		2.3		μs
		ILD5	t_{PLH}		2.5		μs
		ILQ5	t_{PLH}		2.5		μs



ILD1, ILD2, ILD5, ILQ1, ILQ2, ILQ5

Optocoupler, Phototransistor Output Vishay Semiconductors
(Dual, Quad Channel)

SWITCHING CHARACTERISTICS							
PARAMETER	TEST CONDITION	PART	SYMBOL	MIN.	TYP.	MAX.	UNIT
SATURATED							
Current	$V_{CE} = 0.4 \text{ V}, R_L = 1 \text{ k}\Omega, V_{CC} = 5 \text{ V}, V_{TH} = 1.5 \text{ V}$	ILD1	I_F		20		mA
		ILQ1	I_F		20		mA
		ILD2	I_F		5		mA
		ILQ2	I_F		5		mA
		ILD5	I_F		10		mA
		ILQ5	I_F		10		mA
Delay	$V_{CE} = 0.4 \text{ V}, R_L = 1 \text{ k}\Omega, V_{CC} = 5 \text{ V}, V_{TH} = 1.5 \text{ V}$	ILD1	t_D		0.8		μs
		ILQ1	t_D		0.8		μs
		ILD2	t_D		1		μs
		ILQ2	t_D		1		μs
		ILD5	t_D		1.7		μs
		ILQ5	t_D		1.7		μs
Rise time	$V_{CE} = 0.4 \text{ V}, R_L = 1 \text{ k}\Omega, V_{CC} = 5 \text{ V}, V_{TH} = 1.5 \text{ V}$	ILD1	t_r		1.2		μs
		ILQ1	t_r		1.2		μs
		ILD2	t_r		2		μs
		ILQ2	t_r		2		μs
		ILD5	t_r		7		μs
		ILQ5	t_r		7		μs
Storage	$V_{CE} = 0.4 \text{ V}, R_L = 1 \text{ k}\Omega, V_{CC} = 5 \text{ V}, V_{TH} = 1.5 \text{ V}$	ILD1	t_s		7.4		μs
		ILQ1	t_s		7.4		μs
		ILD2	t_s		5.4		μs
		ILQ2	t_s		5.4		μs
		ILD5	t_s		4.6		μs
		ILQ5	t_s		4.6		μs
SATURATED							
Fall time	$V_{CE} = 0.4 \text{ V}, R_L = 1 \text{ k}\Omega, V_{CC} = 5 \text{ V}, V_{TH} = 1.5 \text{ V}$	ILD1	t_f		7.6		μs
		ILQ1	t_f		7.6		μs
		ILD2	t_f		13.5		μs
		ILQ2	t_f		13.5		μs
		ILD5	t_f		20		μs
		ILQ5	t_f		20		μs
Propagation H to L	$V_{CE} = 0.4 \text{ V}, R_L = 1 \text{ k}\Omega, V_{CC} = 5 \text{ V}, V_{TH} = 1.5 \text{ V}$	ILD1	t_{PHL}		1.6		μs
		ILQ1	t_{PHL}		1.6		μs
		ILD2	t_{PHL}		5.4		μs
		ILQ2	t_{PHL}		5.4		μs
		ILD5	t_{PHL}		2.6		μs
		ILQ5	t_{PHL}		2.6		μs
Propagation L to H	$V_{CE} = 0.4 \text{ V}, R_L = 1 \text{ k}\Omega, V_{CC} = 5 \text{ V}, V_{TH} = 1.5 \text{ V}$	ILD1	t_{PLH}		8.6		μs
		ILQ1	t_{PLH}		8.6		μs
		ILD2	t_{PLH}		7.4		μs
		ILQ2	t_{PLH}		7.4		μs
		ILD5	t_{PLH}		7.2		μs
		ILQ5	t_{PLH}		7.2		μs

ILD1, ILD2, ILD5, ILQ1, ILQ2, ILQ5



Vishay Semiconductors Optocoupler, Phototransistor Output
(Dual, Quad Channel)

COMMON MODE TRANSIENT IMMUNITY						
PARAMETER	TEST CONDITION	SYMBOL	MIN.	TYP.	MAX.	UNIT
Common mode rejection, output high	$V_{CM} = 50 V_{P-P}, R_L = 1 k\Omega, I_F = 0 mA$	CM_H		5000		$V/\mu s$
Common mode rejection, output low	$V_{CM} = 50 V_{P-P}, R_L = 1 k\Omega, I_F = 10 mA$	CM_L		5000		$V/\mu s$
Common mode coupling capacitance		C_{CM}		0.01		pF

TYPICAL CHARACTERISTICS ($T_{amb} = 25^\circ C$, unless otherwise specified)

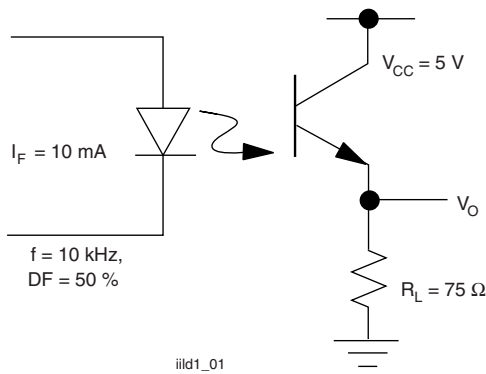

Fig. 1 - Non-Saturated Switching Schematic

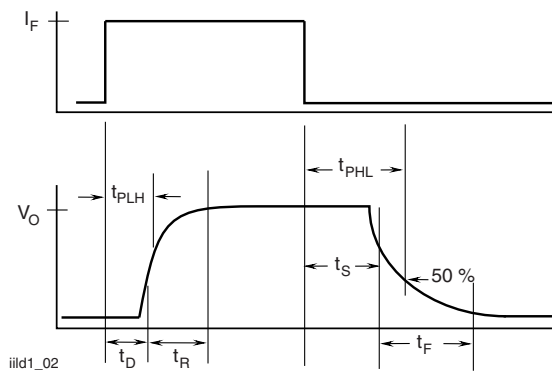

Fig. 2 - Non-Saturated Switching Timing

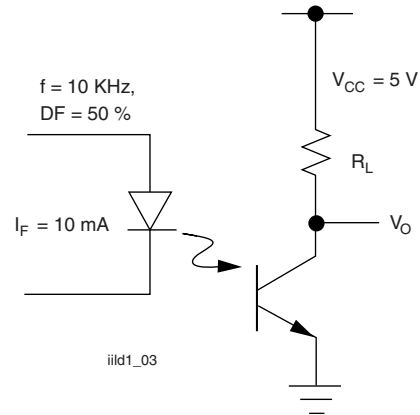

Fig. 3 - Saturated Switching Schematic

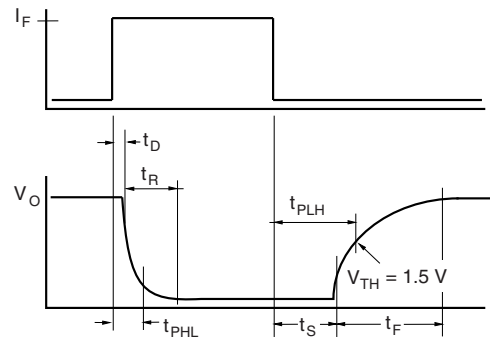

Fig. 4 - Saturated Switching Timing

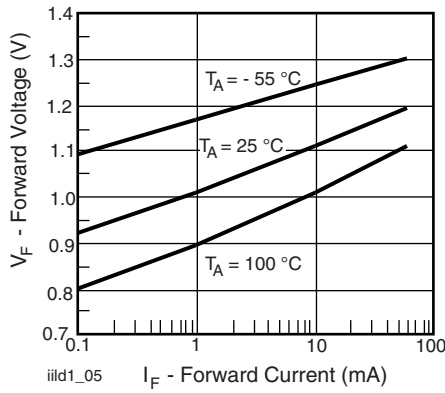

Fig. 5 - Normalized Non-Saturated and Saturated CTR vs. LED Current

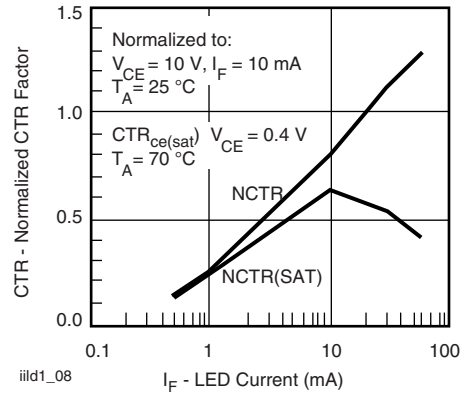

Fig. 8 - Normalized Non-Saturated and Saturated CTR vs. LED Current

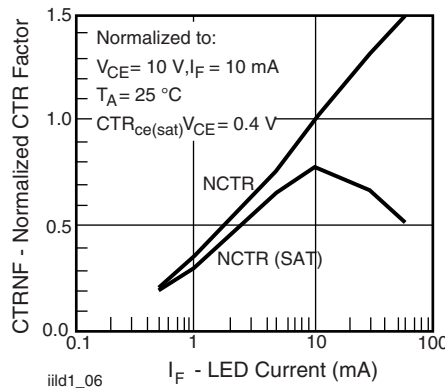

Fig. 6 - Normalized Non-Saturated and Saturated CTR vs. LED Current

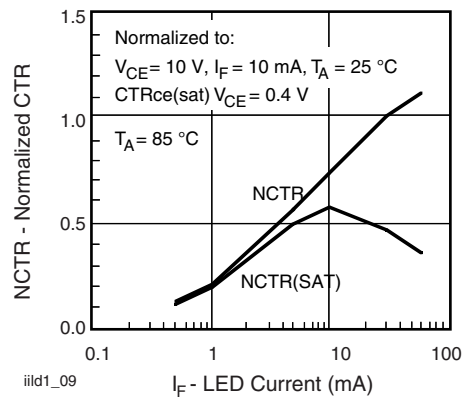

Fig. 9 - Normalized Non-Saturated and Saturated CTR vs. LED Current

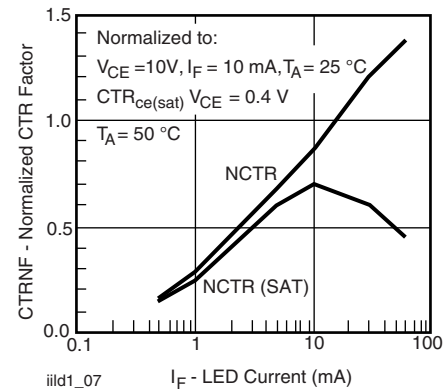

Fig. 7 - Normalized Non-Saturated and Saturated CTR vs. LED Current

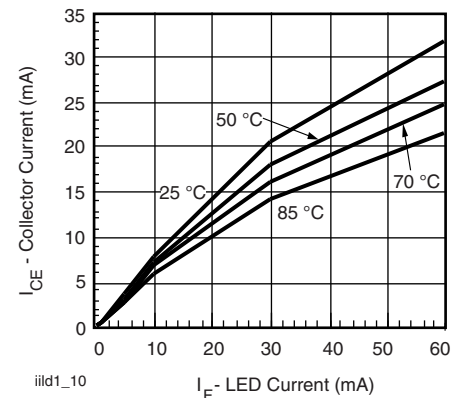

Fig. 10 - Collector Emitter Current vs. Temperature and LED Current

ILD1, ILD2, ILD5, ILQ1, ILQ2, ILQ5



Vishay Semiconductors Optocoupler, Phototransistor Output
(Dual, Quad Channel)

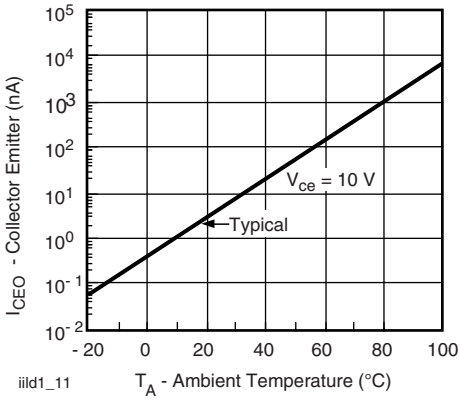

Fig. 11 - Collector Emitter Leakage Current vs. Temperature

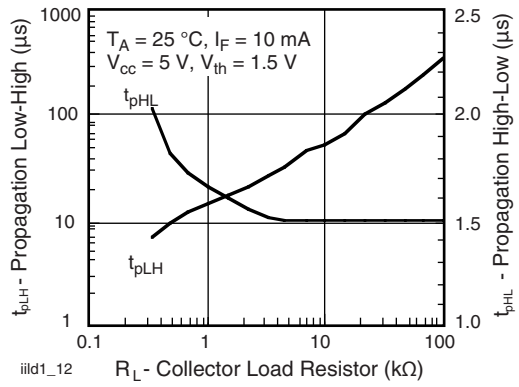
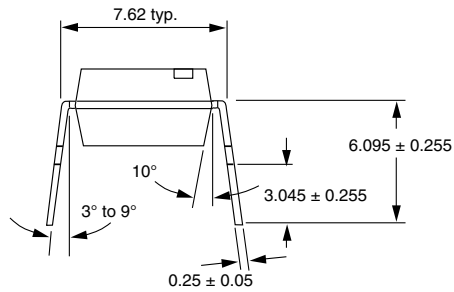
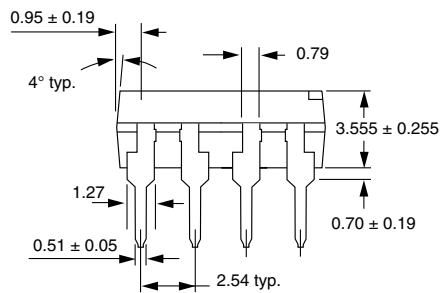
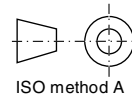
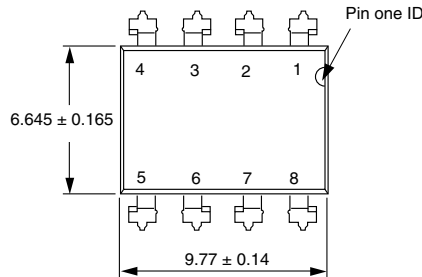

Fig. 12 - Propagation Delay vs. Collector Load Resistor

PACKAGE DIMENSIONS in millimeters



i178006



ILD1, ILD2, ILD5, ILQ1, ILQ2, ILQ5

Optocoupler, Phototransistor Output Vishay Semiconductors
(Dual, Quad Channel)

PACKAGE DIMENSIONS in millimeters

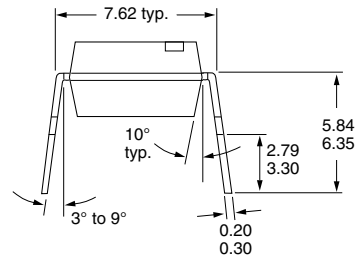
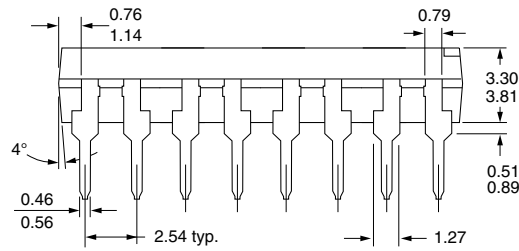
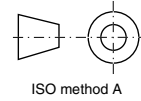
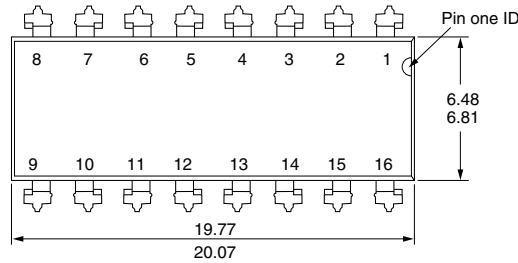

i178007

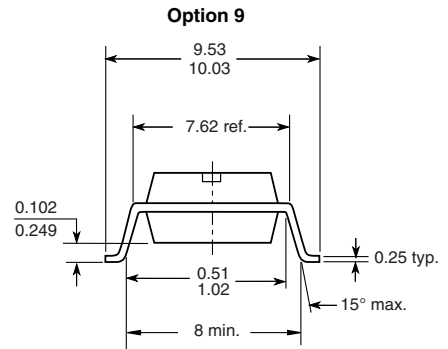
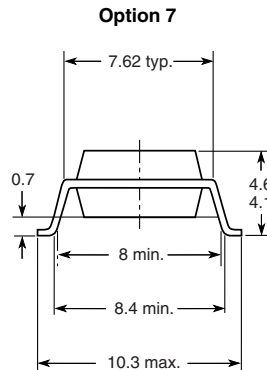
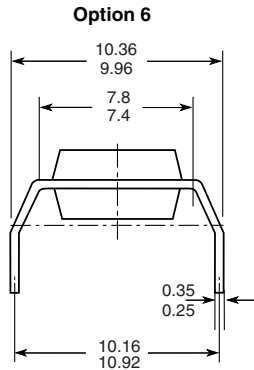

18450



Disclaimer

ALL PRODUCT, PRODUCT SPECIFICATIONS AND DATA ARE SUBJECT TO CHANGE WITHOUT NOTICE TO IMPROVE RELIABILITY, FUNCTION OR DESIGN OR OTHERWISE.

Vishay Intertechnology, Inc., its affiliates, agents, and employees, and all persons acting on its or their behalf (collectively, "Vishay"), disclaim any and all liability for any errors, inaccuracies or incompleteness contained in any datasheet or in any other disclosure relating to any product.

Vishay makes no warranty, representation or guarantee regarding the suitability of the products for any particular purpose or the continuing production of any product. To the maximum extent permitted by applicable law, Vishay disclaims (i) any and all liability arising out of the application or use of any product, (ii) any and all liability, including without limitation special, consequential or incidental damages, and (iii) any and all implied warranties, including warranties of fitness for particular purpose, non-infringement and merchantability.

Statements regarding the suitability of products for certain types of applications are based on Vishay's knowledge of typical requirements that are often placed on Vishay products in generic applications. Such statements are not binding statements about the suitability of products for a particular application. It is the customer's responsibility to validate that a particular product with the properties described in the product specification is suitable for use in a particular application. Parameters provided in datasheets and/or specifications may vary in different applications and performance may vary over time. All operating parameters, including typical parameters, must be validated for each customer application by the customer's technical experts. Product specifications do not expand or otherwise modify Vishay's terms and conditions of purchase, including but not limited to the warranty expressed therein.

Except as expressly indicated in writing, Vishay products are not designed for use in medical, life-saving, or life-sustaining applications or for any other application in which the failure of the Vishay product could result in personal injury or death. Customers using or selling Vishay products not expressly indicated for use in such applications do so at their own risk and agree to fully indemnify and hold Vishay and its distributors harmless from and against any and all claims, liabilities, expenses and damages arising or resulting in connection with such use or sale, including attorneys fees, even if such claim alleges that Vishay or its distributor was negligent regarding the design or manufacture of the part. Please contact authorized Vishay personnel to obtain written terms and conditions regarding products designed for such applications.

No license, express or implied, by estoppel or otherwise, to any intellectual property rights is granted by this document or by any conduct of Vishay. Product names and markings noted herein may be trademarks of their respective owners.