

LQH2MCN6R8M52#

"#" indicates a package specification code.

Size Code 2016 (0806) in mm (in inch), 0.7mm max. Thickness



< List of part numbers with package codes >

LQH2MCN6R8M52L LQH2MCN6R8M52B

Appearance & Shape

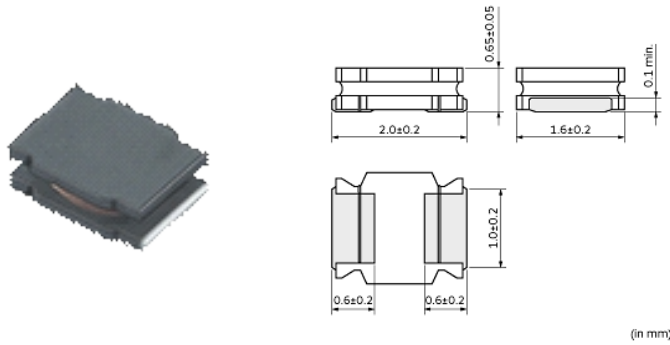

References

Packaging	Specifications	Minimum Order Quantity
L	180 Embossed Tape	3000
B	Bulk(Bag)	100

Mass (typ.)	
1 piece	0.009g

Notices

When rated current is applied to the products, inductance will be within $\pm 10\%$ of initial inductance value. When rated current is applied to the products, the temperature rise caused by self-generated heat shall be limited to 40°C max.

Attention

- 1.This datasheet is downloaded from the website of Murata Manufacturing Co., Ltd. Therefore, it's specifications are subject to change or our products in it may be discontinued without advance notice. Please check with our sales representatives or product engineers before ordering.
 - 2.This datasheet has only typical specifications because there is no space for detailed specifications.
- Therefore, please review our product specifications or consult the approval sheet for product specifications before ordering.

LQH2MCN6R8M52#

“#” indicates a package specification code.

Specifications

L size	2.0±0.2mm
W size	1.6±0.2mm
T size	0.65±0.05mm
Size code inch (mm)	0806 (2016)
Inductance	6.8μH±20%
Inductance Test Frequency	1MHz
Rated current (Itemp) (Based on Temperature rise)	285mA
Max. of DC resistance	1.6Ω
Class of magnetic shield	No Shield
Self resonance frequency (min.)	65MHz
Operating Temperature Range(Self-temperature rise is not included)	-40°C to 85°C
DC Resistance Intermediate Values	1.23Ω±30%
Series	LQH2MCN_52

Attention

1.This datasheet is downloaded from the website of Murata Manufacturing Co., Ltd. Therefore, it's specifications are subject to change or our products in it may be discontinued without advance notice. Please check with our sales representatives or product engineers before ordering.

2.This datasheet has only typical specifications because there is no space for detailed specifications.

Therefore, please review our product specifications or consult the approval sheet for product specifications before ordering.

LQH2MCN6R8M52#

"#" indicates a package specification code.

Characteristic Data

The charts below may show another part number which shares its characteristics.

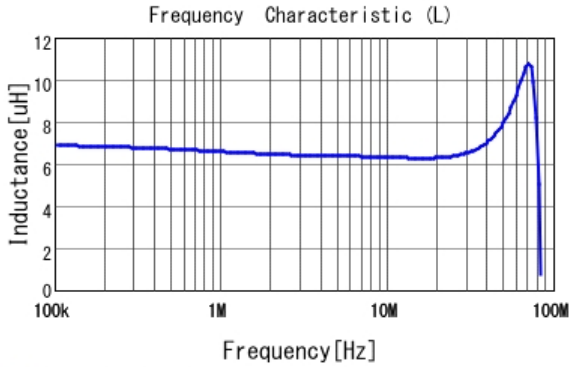

LQH2MCN6R8M52 L

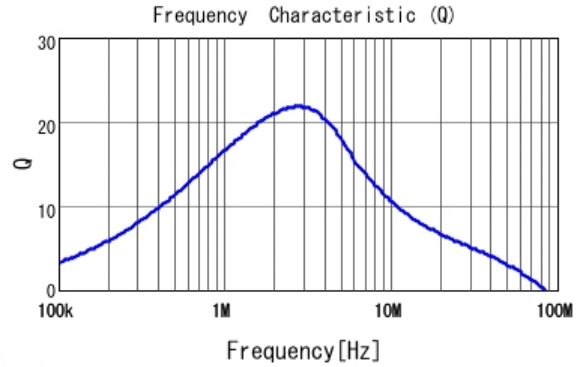

LQH2MCN6R8M52 Q

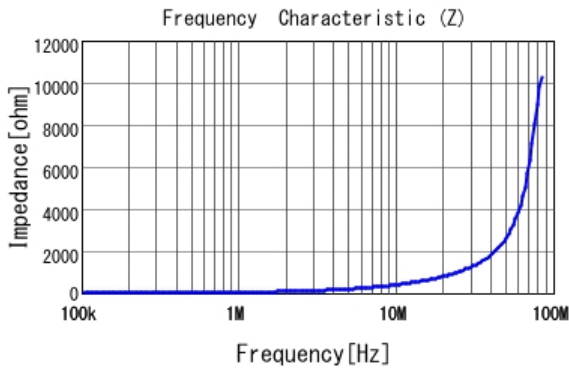

LQH2MCN6R8M52 |Z|

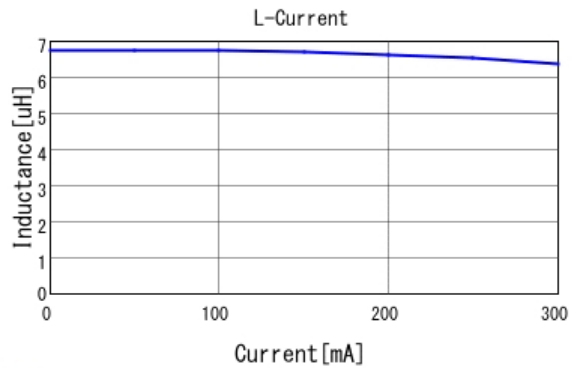

LQH2MCN6R8M52 L-Current 20degC

Attention

1.This datasheet is downloaded from the website of Murata Manufacturing Co., Ltd. Therefore, it's specifications are subject to change or our products in it may be discontinued without advance notice. Please check with our sales representatives or product engineers before ordering.

2.This datasheet has only typical specifications because there is no space for detailed specifications.

Therefore, please review our product specifications or consult the approval sheet for product specifications before ordering.

LQH2MCN6R8M52#

"#" indicates a package specification code.

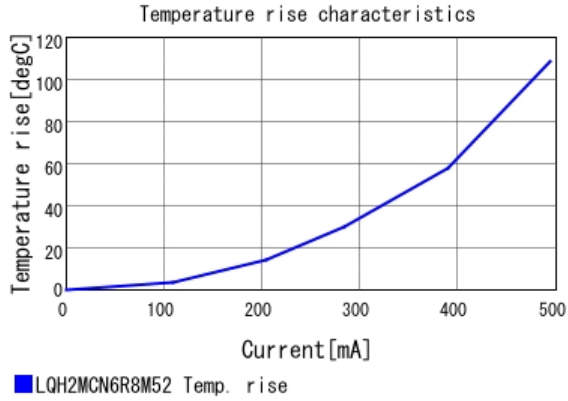

Attention

- 1.This datasheet is downloaded from the website of Murata Manufacturing Co., Ltd. Therefore, it's specifications are subject to change or our products in it may be discontinued without advance notice. Please check with our sales representatives or product engineers before ordering.
 - 2.This datasheet has only typical specifications because there is no space for detailed specifications.
- Therefore, please review our product specifications or consult the approval sheet for product specifications before ordering.