



MACRONIX
INTERNATIONAL Co., LTD.

MX29LV400C T/B
MX29LV800C T/B
MX29LV160C T/B

MX29LV400C T/B, MX29LV800C T/B, MX29LV160C T/B DATASHEET

The MX29LV160C T/B product will be phase-out, and is not recommended for new design. The MX29LV160C T/B will be migrated to MX29LV160D T/B, which is a functional compatible product. Please refer to MX29LV160D T/B datasheet for new design.

SINGLE VOLTAGE 3V ONLY FLASH MEMORY

The MX29LV160C T/B product will be phase-out, and is not recommended for new design. The MX29LV160C T/B will be migrated to MX29LV160D T/B, which is a functional compatible product. Please refer to MX29LV160D T/B datasheet for new design.

FEATURES**GENERAL FEATURES**

- Byte/Word mode switchable:
 - 524,288 x8 / 262,144 x16 (MX29LV400C)
 - 1,048,576 x8 / 524,288 x16 (MX29LV800C)
 - 2,097,152 x8 / 1,048,576 x16 (MX29LV160C)
- Sector Structure
 - 16K-Byte x 1, 8K-Byte x 2, 32K-Byte x 1
64K-Byte x 7 (MX29LV400C), 64K-Byte x 15 (MX29LV800C), 64K-Byte x 31 (MX29LV160C)
 - Provides sector protect function to prevent program or erase operation in the protected sector
 - Provides chip unprotect function to allow code changing
 - Provides temporary sector unprotect function for code changing in previously protected sector
- Single Power Supply Operation
 - 2.7 to 3.6 volt for read, erase, and program operations
- Latch-up protected to 250mA from -1V to Vcc + 1V
- Low Vcc write inhibit : Vcc <= 1.4V
- Compatible with JEDEC standard
 - Pinout and software compatible to single power supply Flash
- **Functional compatible with MX29LV400B/MX29LV800B/MX29LV160B device**

PERFORMANCE

- High Performance
 - Fast access time: 45R (MX29LV400C and MX29LV800C only), 55R/70/90ns
 - Fast program time: 7us/word typical utilizing accelerate function
 - Fast erase time: 0.7s/sector, 15s/chip (typical, MX29LV160C)
- Low Power Consumption
 - Low active read current: 10mA (typical) at 5MHz
 - Low standby current: 200nA (typical)
- Minimum 100,000 erase/program cycle
- 10 years data retention

SOFTWARE FEATURES

- Erase Suspend/ Erase Resume
 - Suspends sector erase operation to read data from or program data to another sector which is not being erased
- Status Reply
 - Data# Polling & Toggle bits provide detection of program and erase operation completion
- Support Common Flash Interface (CFI)

HARDWARE FEATURES

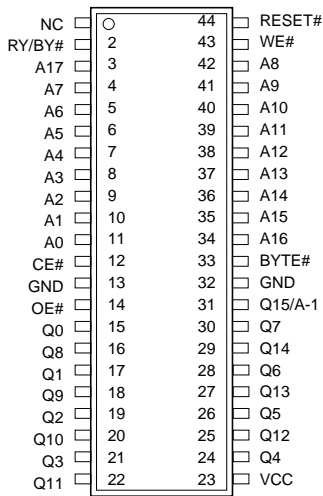
- Ready/Busy# (RY/BY#) Output
 - Provides a hardware method of detecting program and erase operation completion
- Hardware Reset (RESET#) Input
 - Provides a hardware method to reset the internal state machine to read mode

PACKAGE

- 44-Pin SOP
- 48-Pin TSOP
- 48-Ball TFBGA
- 48-Ball LFBGA
- 48-Ball WFBGA
- 48-Ball XFLGA
- All Pb-free devices are RoHS Compliant

MX29LV400C PIN CONFIGURATIONS

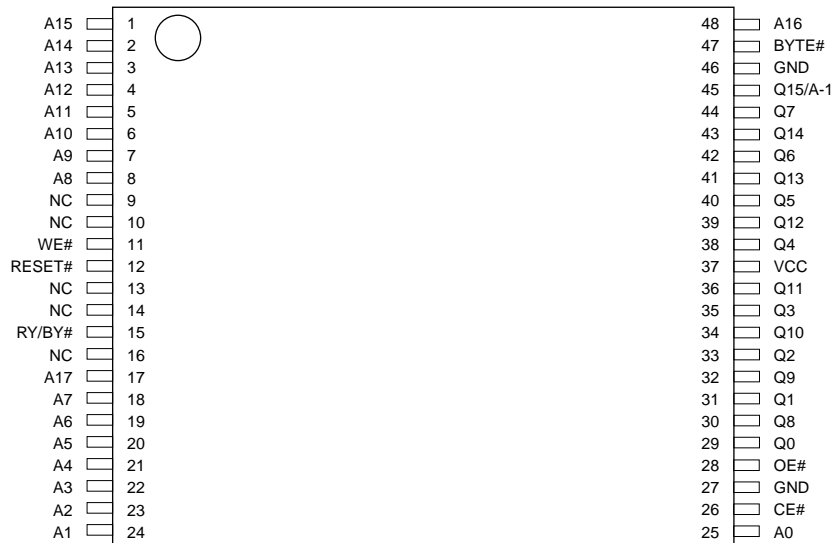
MX29LV400C 44 SOP(500 mil)



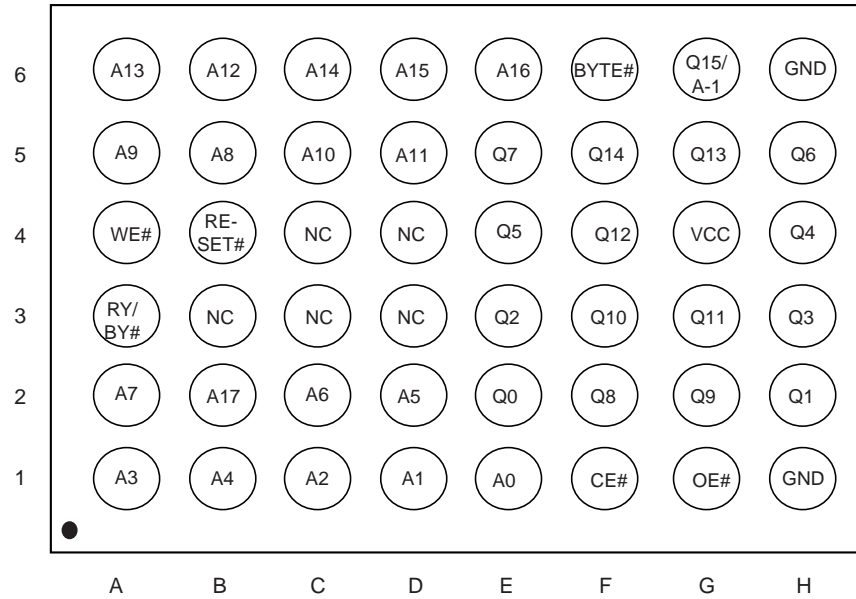
PIN DESCRIPTION

| SYMBOL | PIN NAME |
|---------|---|
| A0~A17 | Address Input |
| Q0~Q14 | Data Input/Output |
| Q15/A-1 | Q15 (Word mode)/LSB addr(Byte mode) |
| CE# | Chip Enable Input |
| WE# | Write Enable Input |
| BYTE# | Word/Byte Selection input |
| RESET# | Hardware Reset Pin/Sector Protect Unlock |
| OE# | Output Enable Input |
| RY/BY# | Ready/Busy Output |
| VCC | Power Supply Pin (2.7V~3.6V) |
| GND | Ground Pin |
| NC | Pin Not Connected Internally |

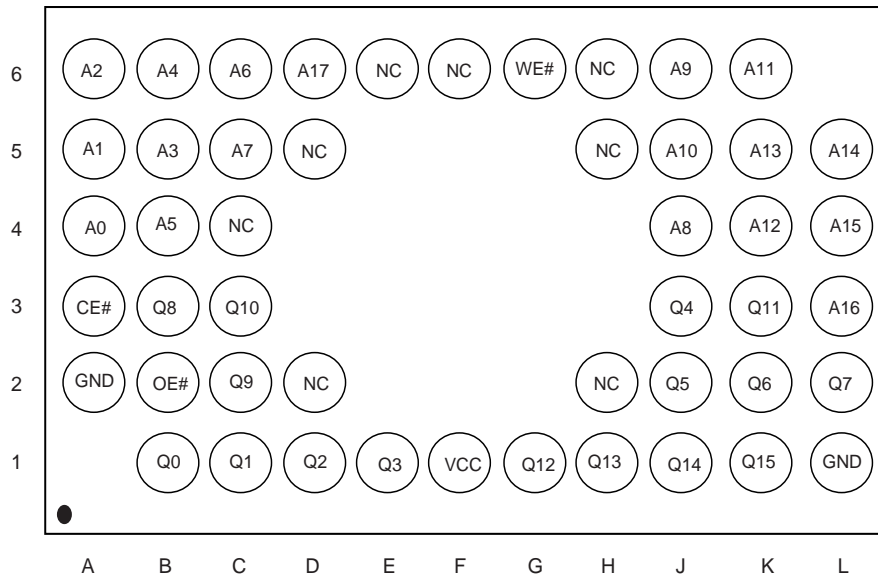
MX29LV400C 48 TSOP (Standard Type) (12mm x 20mm)



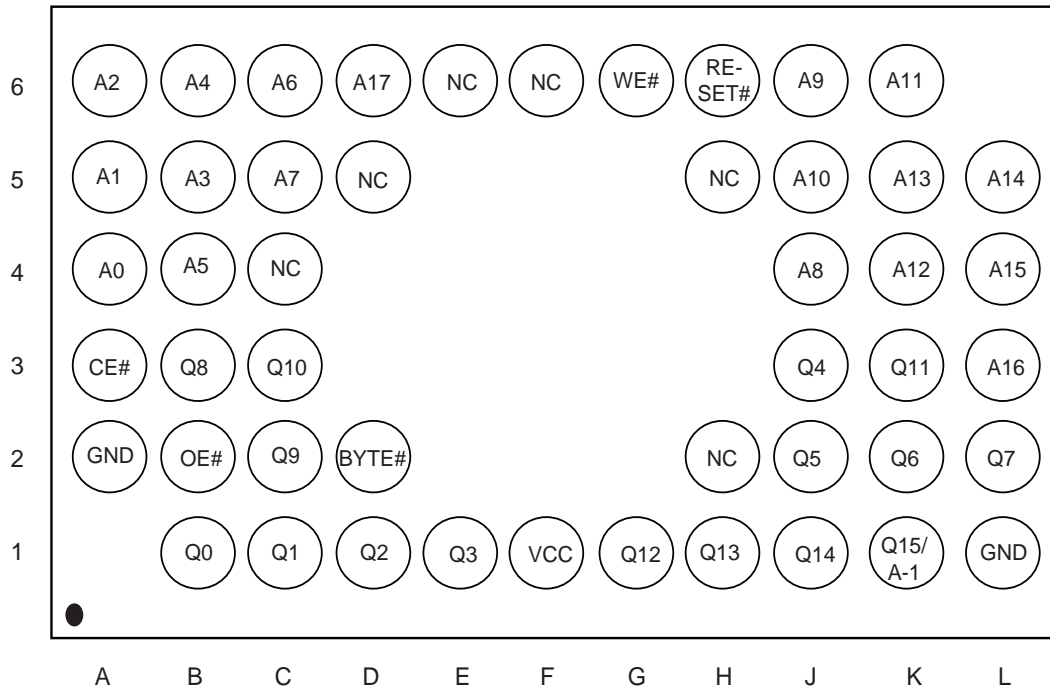
MX29LV400C 48-Ball TFBGA/LFBGA (Ball Pitch = 0.8 mm, Top View, Balls Facing Down, 6 x 8 mm)



MX29LV400C 48-Ball WFBGA (Balls Facing Down, 4 x 6 x 0.75 mm)

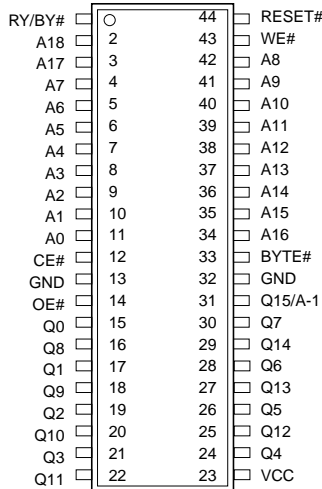


MX29LV400C 48-Ball XFLGA (Balls Facing Down, 4 x 6 x 0.5 mm)



MX29LV800C PIN CONFIGURATIONS

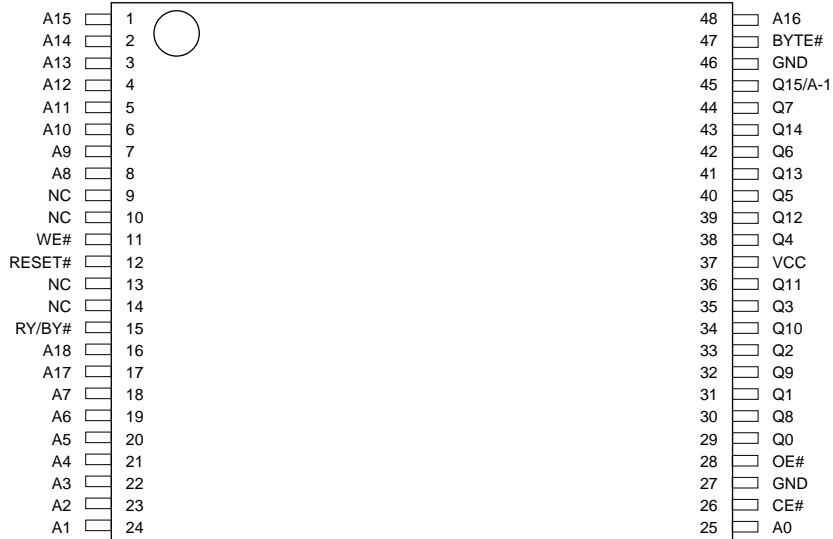
MX29LV800C 44 SOP(500 mil)



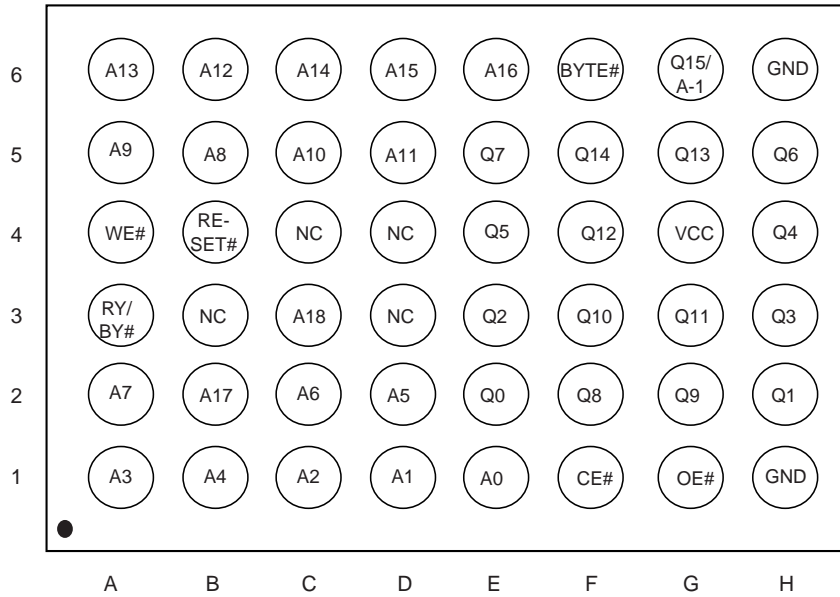
PIN DESCRIPTION

| SYMBOL | PIN NAME |
|---------|------------------------------------|
| A0~A18 | Address Input |
| Q0~Q14 | Data Input/Output |
| Q15/A-1 | Q15(Word mode)/LSB addr(Byte mode) |
| CE# | Chip Enable Input |
| WE# | Write Enable Input |
| BYTE# | Word/Byte Selection input |
| RESET# | Hardware Reset Pin |
| OE# | Output Enable Input |
| RY/BY# | Ready/Busy Output |
| VCC | Power Supply Pin (2.7V~3.6V) |
| GND | Ground Pin |
| NC | Pin Not Connected Internally |

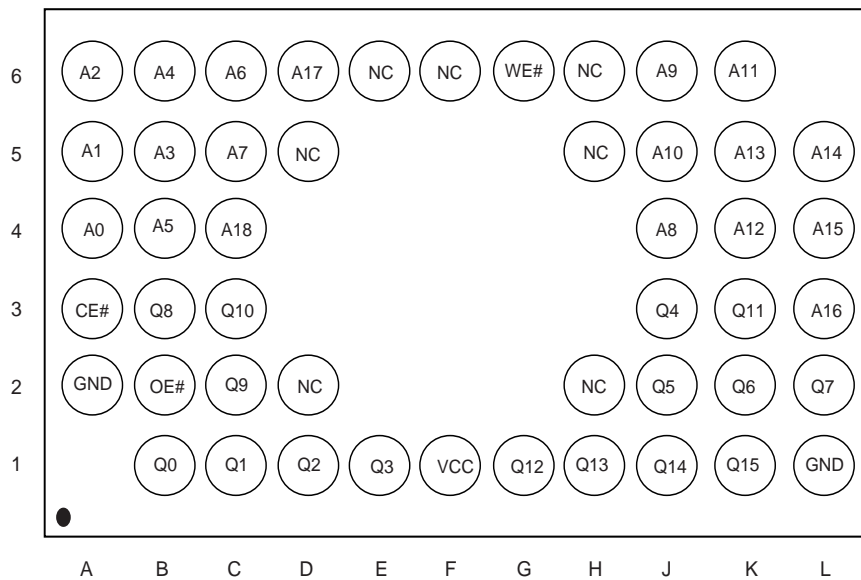
MX29LV800C 48 TSOP (Standard Type) (12mm x 20mm)



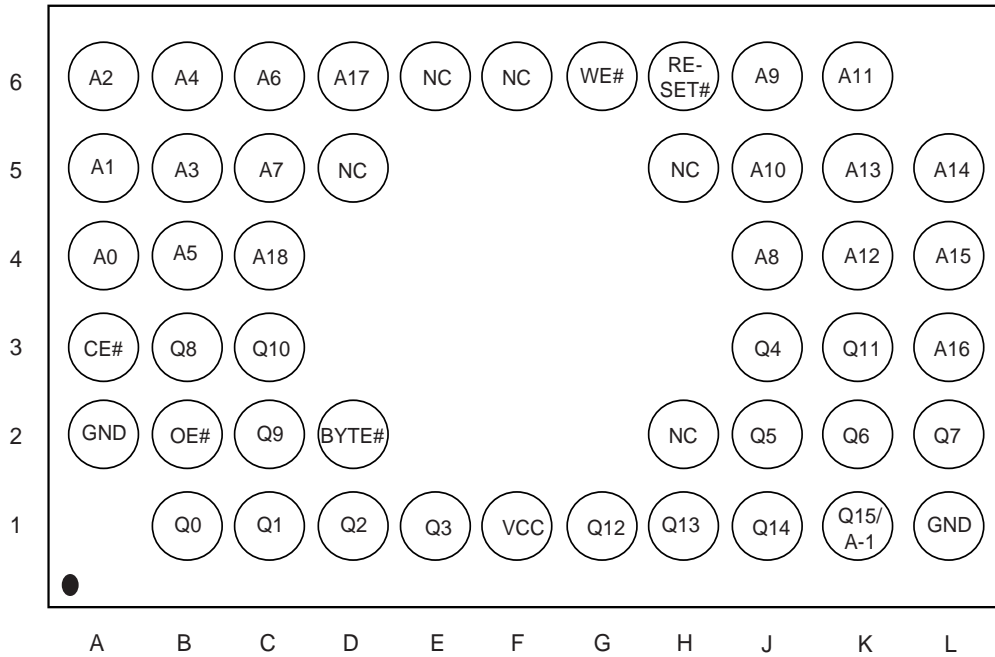
MX29LV800C 48-Ball TFBGA/LFBGA (Ball Pitch = 0.8 mm, Top View, Balls Facing Down, 6 x 8 mm)



MX29LV800C 48-Ball WFBGA (Balls Facing Down, 4 x 6 x 0.75 mm)

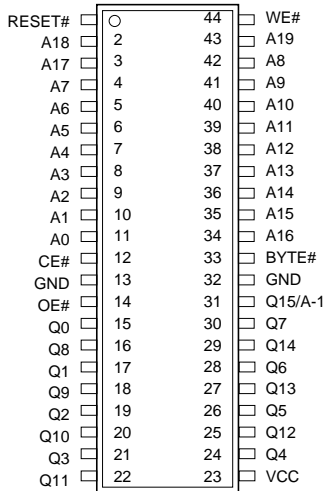


MX29LV800C 48-Ball XFLGA (Balls Facing Down, 4 x 6 x 0.5 mm)



MX29LV160C PIN CONFIGURATIONS

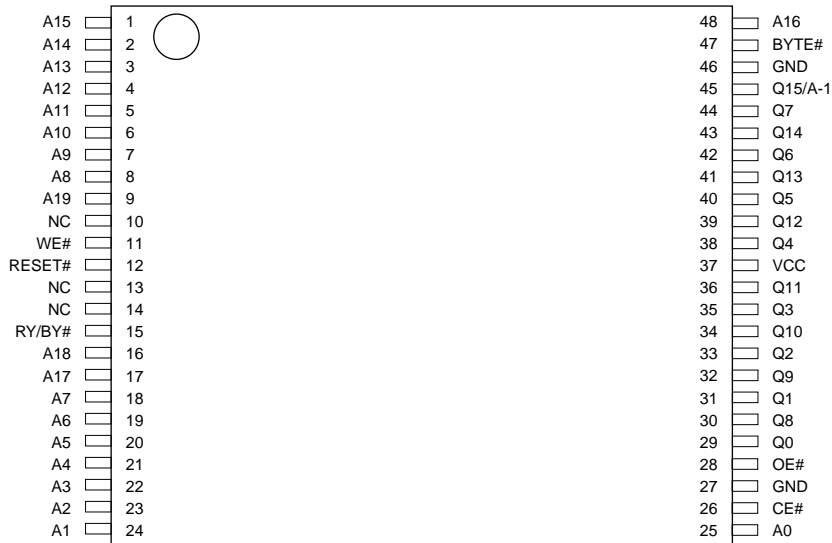
MX29LV160C 44 SOP(500 mil)



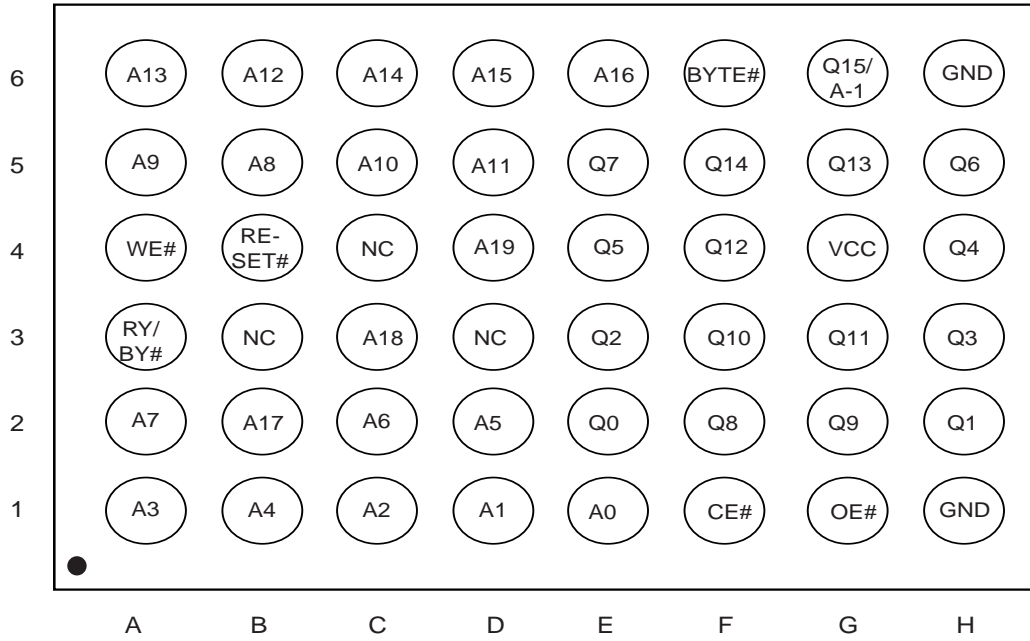
PIN DESCRIPTION

| SYMBOL | PIN NAME |
|---------|--|
| A0~A19 | Address Input |
| Q0~Q14 | Data Input/Output |
| Q15/A-1 | Q15(Word mode)/LSB addr(Byte mode) |
| CE# | Chip Enable Input |
| WE# | Write Enable Input |
| BYTE# | Word/Byte Selection input |
| RESET# | Hardware Reset Pin/Sector Protect Unlock |
| OE# | Output Enable Input |
| RY/BY# | Ready/Busy Output |
| VCC | Power Supply Pin (2.7V~3.6V) |
| GND | Ground Pin |

MX29LV160C 48 TSOP (Standard Type) (12mm x 20mm)



MX29LV160C 48-Ball TFBGA/LFBGA (Ball Pitch = 0.8 mm, Top View, Balls Facing Down, 6 x 8 mm)



BLOCK DIAGRAM

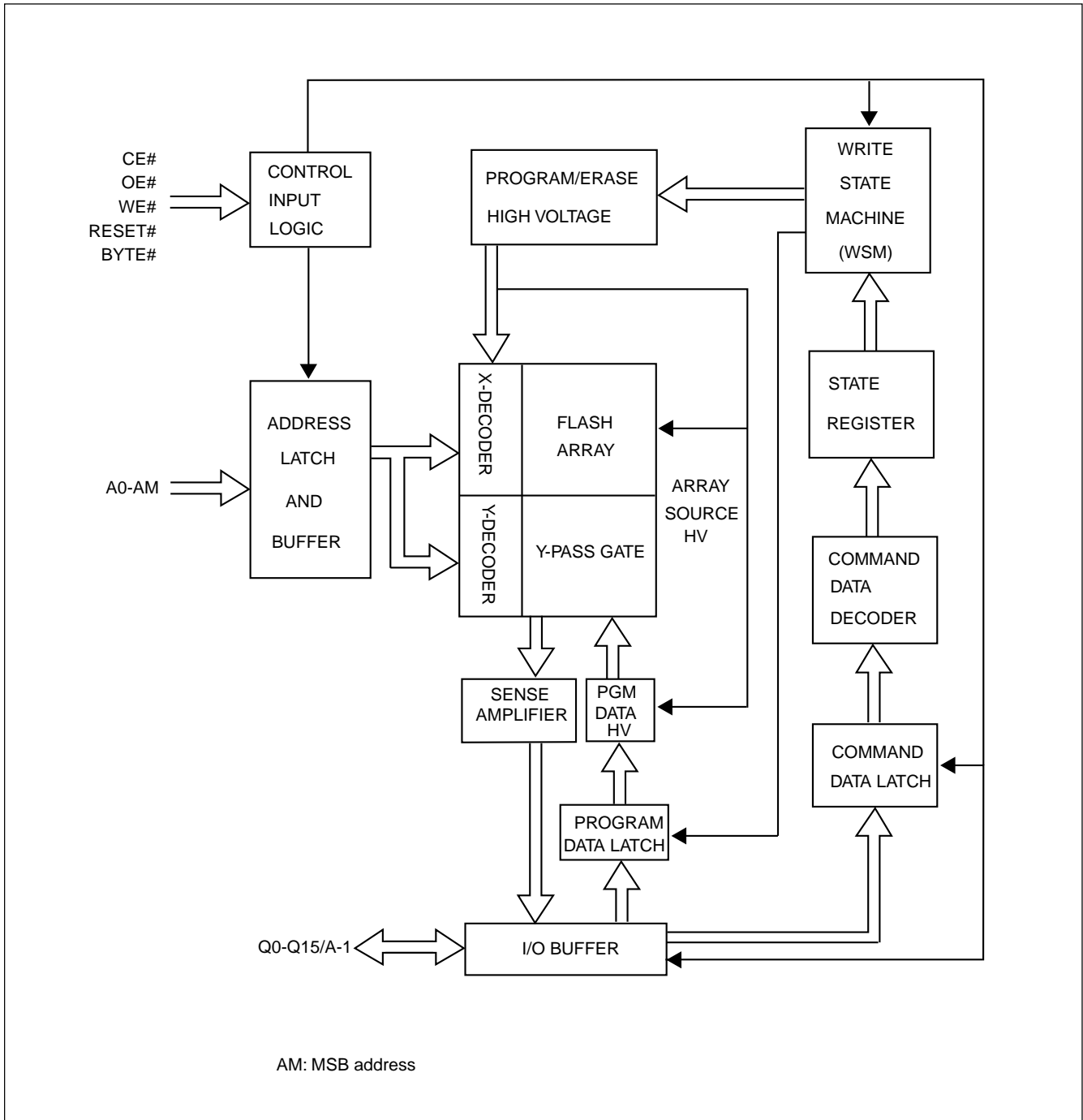


Table 1. BLOCK STRUCTURE

MX29LV400CT SECTOR ARCHITECTURE

| Sector | Sector Size | | Address range | | Sector Address | | | | | |
|--------|-------------|-----------|----------------|-----------------|----------------|-----|-----|-----|-----|-----|
| | Byte Mode | Word Mode | Byte Mode (x8) | Word Mode (x16) | A17 | A16 | A15 | A14 | A13 | A12 |
| SA0 | 64Kbytes | 32Kwords | 00000-0FFFF | 00000-07FFF | 0 | 0 | 0 | X | X | X |
| SA1 | 64Kbytes | 32Kwords | 10000-1FFFF | 08000-0FFFF | 0 | 0 | 1 | X | X | X |
| SA2 | 64Kbytes | 32Kwords | 20000-2FFFF | 10000-17FFF | 0 | 1 | 0 | X | X | X |
| SA3 | 64Kbytes | 32Kwords | 30000-3FFFF | 18000-1FFFF | 0 | 1 | 1 | X | X | X |
| SA4 | 64Kbytes | 32Kwords | 40000-4FFFF | 20000-27FFF | 1 | 0 | 0 | X | X | X |
| SA5 | 64Kbytes | 32Kwords | 50000-5FFFF | 28000-2FFFF | 1 | 0 | 1 | X | X | X |
| SA6 | 64Kbytes | 32Kwords | 60000-6FFFF | 30000-37FFF | 1 | 1 | 0 | X | X | X |
| SA7 | 32Kbytes | 16Kwords | 70000-77FFF | 38000-3BFFF | 1 | 1 | 1 | 0 | X | X |
| SA8 | 8Kbytes | 4Kwords | 78000-79FFF | 3C000-3CFFF | 1 | 1 | 1 | 1 | 0 | 0 |
| SA9 | 8Kbytes | 4Kwords | 7A000-7BFFF | 3D000-3DFFF | 1 | 1 | 1 | 1 | 0 | 1 |
| SA10 | 16Kbytes | 8Kwords | 7C000-7FFFF | 3E000-3FFFF | 1 | 1 | 1 | 1 | 1 | X |

MX29LV400CB SECTOR ARCHITECTURE

| Sector | Sector Size | | Address range | | Sector Address | | | | | |
|--------|-------------|-----------|----------------|-----------------|----------------|-----|-----|-----|-----|-----|
| | Byte Mode | Word Mode | Byte Mode (x8) | Word Mode (x16) | A17 | A16 | A15 | A14 | A13 | A12 |
| SA0 | 16Kbytes | 8Kwords | 00000-03FFF | 00000-01FFF | 0 | 0 | 0 | 0 | 0 | X |
| SA1 | 8Kbytes | 4Kwords | 04000-05FFF | 02000-02FFF | 0 | 0 | 0 | 0 | 1 | 0 |
| SA2 | 8Kbytes | 4Kwords | 06000-07FFF | 03000-03FFF | 0 | 0 | 0 | 0 | 1 | 1 |
| SA3 | 32Kbytes | 16Kwords | 08000-0FFFF | 04000-07FFF | 0 | 0 | 0 | 1 | X | X |
| SA4 | 64Kbytes | 32Kwords | 10000-1FFFF | 08000-0FFFF | 0 | 0 | 1 | X | X | X |
| SA5 | 64Kbytes | 32Kwords | 20000-2FFFF | 10000-17FFF | 0 | 1 | 0 | X | X | X |
| SA6 | 64Kbytes | 32Kwords | 30000-3FFFF | 18000-1FFFF | 0 | 1 | 1 | X | X | X |
| SA7 | 64Kbytes | 32Kwords | 40000-4FFFF | 20000-27FFF | 1 | 0 | 0 | X | X | X |
| SA8 | 64Kbytes | 32Kwords | 50000-5FFFF | 28000-2FFFF | 1 | 0 | 1 | X | X | X |
| SA9 | 64Kbytes | 32Kwords | 60000-6FFFF | 30000-37FFF | 1 | 1 | 0 | X | X | X |
| SA10 | 64Kbytes | 32Kwords | 70000-7FFFF | 38000-3FFFF | 1 | 1 | 1 | X | X | X |



MX29LV800CT SECTOR ARCHITECTURE

| Sector | Sector Size | | Address range | | Sector Address | | | | | | |
|--------|-------------|-----------|----------------|-----------------|----------------|-----|-----|-----|-----|-----|-----|
| | Byte Mode | Word Mode | Byte Mode (x8) | Word Mode (x16) | A18 | A17 | A16 | A15 | A14 | A13 | A12 |
| SA0 | 64Kbytes | 32Kwords | 00000h-0FFFFh | 00000h-07FFFh | 0 | 0 | 0 | 0 | X | X | X |
| SA1 | 64Kbytes | 32Kwords | 10000h-1FFFFh | 08000h-0FFFFh | 0 | 0 | 0 | 1 | X | X | X |
| SA2 | 64Kbytes | 32Kwords | 20000h-2FFFFh | 10000h-17FFFh | 0 | 0 | 1 | 0 | X | X | X |
| SA3 | 64Kbytes | 32Kwords | 30000h-3FFFFh | 18000h-1FFFFh | 0 | 0 | 1 | 1 | X | X | X |
| SA4 | 64Kbytes | 32Kwords | 40000h-4FFFFh | 20000h-27FFFh | 0 | 1 | 0 | 0 | X | X | X |
| SA5 | 64Kbytes | 32Kwords | 50000h-5FFFFh | 28000h-2FFFFh | 0 | 1 | 0 | 1 | X | X | X |
| SA6 | 64Kbytes | 32Kwords | 60000h-6FFFFh | 30000h-37FFFh | 0 | 1 | 1 | 0 | X | X | X |
| SA7 | 64Kbytes | 32Kwords | 70000h-7FFFFh | 38000h-3FFFFh | 0 | 1 | 1 | 1 | X | X | X |
| SA8 | 64Kbytes | 32Kwords | 80000h-8FFFFh | 40000h-47FFFh | 1 | 0 | 0 | 0 | X | X | X |
| SA9 | 64Kbytes | 32Kwords | 90000h-9FFFFh | 48000h-4FFFFh | 1 | 0 | 0 | 1 | X | X | X |
| SA10 | 64Kbytes | 32Kwords | A0000h-AFFFFh | 50000h-57FFFh | 1 | 0 | 1 | 0 | X | X | X |
| SA11 | 64Kbytes | 32Kwords | B0000h-BFFFFh | 58000h-5FFFFh | 1 | 0 | 1 | 1 | X | X | X |
| SA12 | 64Kbytes | 32Kwords | C0000h-CFFFFh | 60000h-67FFFh | 1 | 1 | 0 | 0 | X | X | X |
| SA13 | 64Kbytes | 32Kwords | D0000h-DFFFFh | 68000h-6FFFFh | 1 | 1 | 0 | 1 | X | X | X |
| SA14 | 64Kbytes | 32Kwords | E0000h-EFFFFh | 70000h-77FFFh | 1 | 1 | 1 | 0 | X | X | X |
| SA15 | 32Kbytes | 16Kwords | F0000h-F7FFFh | 78000h-7BFFFh | 1 | 1 | 1 | 1 | 0 | X | X |
| SA16 | 8Kbytes | 4Kwords | F8000h-F9FFFh | 7C000h-7CFFFh | 1 | 1 | 1 | 1 | 1 | 0 | 0 |
| SA17 | 8Kbytes | 4Kwords | FA000h-FBFFFh | 7D000h-7DFFFh | 1 | 1 | 1 | 1 | 1 | 0 | 1 |
| SA18 | 16Kbytes | 8Kwords | FC000h-FFFFh | 7E000h-7FFFFh | 1 | 1 | 1 | 1 | 1 | 1 | X |

MX29LV800CB SECTOR ARCHITECTURE

| Sector | Sector Size | | Address range | | Sector Address | | | | | | |
|--------|-------------|-----------|----------------|-----------------|----------------|-----|-----|-----|-----|-----|-----|
| | Byte Mode | Word Mode | Byte Mode (x8) | Word Mode (x16) | A18 | A17 | A16 | A15 | A14 | A13 | A12 |
| SA0 | 16Kbytes | 8Kwords | 00000h-03FFFh | 00000h-01FFFh | 0 | 0 | 0 | 0 | 0 | 0 | X |
| SA1 | 8Kbytes | 4Kwords | 04000h-05FFFh | 02000h-02FFFh | 0 | 0 | 0 | 0 | 0 | 1 | 0 |
| SA2 | 8Kbytes | 4Kwords | 06000h-07FFFh | 03000h-03FFFh | 0 | 0 | 0 | 0 | 0 | 1 | 1 |
| SA3 | 32Kbytes | 16Kwords | 08000h-0FFFFh | 04000h-07FFFh | 0 | 0 | 0 | 0 | 1 | X | X |
| SA4 | 64Kbytes | 32Kwords | 10000h-1FFFFh | 08000h-0FFFFh | 0 | 0 | 0 | 1 | X | X | X |
| SA5 | 64Kbytes | 32Kwords | 20000h-2FFFFh | 10000h-17FFFh | 0 | 0 | 1 | 0 | X | X | X |
| SA6 | 64Kbytes | 32Kwords | 30000h-3FFFFh | 18000h-1FFFFh | 0 | 0 | 1 | 1 | X | X | X |
| SA7 | 64Kbytes | 32Kwords | 40000h-4FFFFh | 20000h-27FFFh | 0 | 1 | 0 | 0 | X | X | X |
| SA8 | 64Kbytes | 32Kwords | 50000h-5FFFFh | 28000h-2FFFFh | 0 | 1 | 0 | 1 | X | X | X |
| SA9 | 64Kbytes | 32Kwords | 60000h-6FFFFh | 30000h-37FFFh | 0 | 1 | 1 | 0 | X | X | X |
| SA10 | 64Kbytes | 32Kwords | 70000h-7FFFFh | 38000h-3FFFFh | 0 | 1 | 1 | 1 | X | X | X |
| SA11 | 64Kbytes | 32Kwords | 80000h-8FFFFh | 40000h-47FFFh | 1 | 0 | 0 | 0 | X | X | X |
| SA12 | 64Kbytes | 32Kwords | 90000h-9FFFFh | 48000h-4FFFFh | 1 | 0 | 0 | 1 | X | X | X |
| SA13 | 64Kbytes | 32Kwords | A0000h-AFFFFh | 50000h-57FFFh | 1 | 0 | 1 | 0 | X | X | X |
| SA14 | 64Kbytes | 32Kwords | B0000h-BFFFFh | 58000h-5FFFFh | 1 | 0 | 1 | 1 | X | X | X |
| SA15 | 64Kbytes | 32Kwords | C0000h-CFFFFh | 60000h-67FFFh | 1 | 1 | 0 | 0 | X | X | X |
| SA16 | 64Kbytes | 32Kwords | D0000h-DFFFFh | 68000h-6FFFFh | 1 | 1 | 0 | 1 | X | X | X |
| SA17 | 64Kbytes | 32Kwords | E0000h-EFFFFh | 70000h-77FFFh | 1 | 1 | 1 | 0 | X | X | X |
| SA18 | 64Kbytes | 32Kwords | F0000h-FFFFFh | 78000h-7FFFFh | 1 | 1 | 1 | 1 | X | X | X |



MACRONIX
INTERNATIONAL Co., LTD.

MX29LV400C T/B
MX29LV800C T/B
MX29LV160C T/B

MX29LV160CT SECTOR ARCHITECTURE

| Sector | Sector Size | | Address range | | Sector Address | | | | | | | |
|--------|-------------|-----------|---------------|----------------|----------------|-----|-----|-----|-----|-----|-----|-----|
| | Byte Mode | Word Mode | Byte Mode(x8) | Word Mode(x16) | A19 | A18 | A17 | A16 | A15 | A14 | A13 | A12 |
| SA0 | 64Kbytes | 32Kwords | 000000-00FFFF | 00000-07FFF | 0 | 0 | 0 | 0 | 0 | X | X | X |
| SA1 | 64Kbytes | 32Kwords | 010000-01FFFF | 08000-0FFFF | 0 | 0 | 0 | 0 | 1 | X | X | X |
| SA2 | 64Kbytes | 32Kwords | 020000-02FFFF | 10000-17FFF | 0 | 0 | 0 | 1 | 0 | X | X | X |
| SA3 | 64Kbytes | 32Kwords | 030000-03FFFF | 18000-1FFFF | 0 | 0 | 0 | 1 | 1 | X | X | X |
| SA4 | 64Kbytes | 32Kwords | 040000-04FFFF | 20000-27FFF | 0 | 0 | 1 | 0 | 0 | X | X | X |
| SA5 | 64Kbytes | 32Kwords | 050000-05FFFF | 28000-2FFFF | 0 | 0 | 1 | 0 | 1 | X | X | X |
| SA6 | 64Kbytes | 32Kwords | 060000-06FFFF | 30000-37FFF | 0 | 0 | 1 | 1 | 0 | X | X | X |
| SA7 | 64Kbytes | 32Kwords | 070000-07FFFF | 38000-3FFFF | 0 | 0 | 1 | 1 | 1 | X | X | X |
| SA8 | 64Kbytes | 32Kwords | 080000-08FFFF | 40000-47FFF | 0 | 1 | 0 | 0 | 0 | X | X | X |
| SA9 | 64Kbytes | 32Kwords | 090000-09FFFF | 48000-4FFFF | 0 | 1 | 0 | 0 | 1 | X | X | X |
| SA10 | 64Kbytes | 32Kwords | 0A0000-0AFFFF | 50000-57FFF | 0 | 1 | 0 | 1 | 0 | X | X | X |
| SA11 | 64Kbytes | 32Kwords | 0B0000-0BFFFF | 58000-5FFFF | 0 | 1 | 0 | 1 | 1 | X | X | X |
| SA12 | 64Kbytes | 32Kwords | 0C0000-0CFFFF | 60000-67FFF | 0 | 1 | 1 | 0 | 0 | X | X | X |
| SA13 | 64Kbytes | 32Kwords | 0D0000-0DFFFF | 68000-6FFFF | 0 | 1 | 1 | 0 | 1 | X | X | X |
| SA14 | 64Kbytes | 32Kwords | 0E0000-0EFFFF | 70000-77FFF | 0 | 1 | 1 | 1 | 0 | X | X | X |
| SA15 | 64Kbytes | 32Kwords | 0F0000-0FFFFF | 78000-7FFFF | 0 | 1 | 1 | 1 | 1 | X | X | X |
| SA16 | 64Kbytes | 32Kwords | 100000-10FFFF | 80000-87FFF | 1 | 0 | 0 | 0 | 0 | X | X | X |
| SA17 | 64Kbytes | 32Kwords | 110000-11FFFF | 88000-8FFFF | 1 | 0 | 0 | 0 | 1 | X | X | X |
| SA18 | 64Kbytes | 32Kwords | 120000-12FFFF | 90000-97FFF | 1 | 0 | 0 | 1 | 0 | X | X | X |
| SA19 | 64Kbytes | 32Kwords | 130000-13FFFF | 98000-9FFFF | 1 | 0 | 0 | 1 | 1 | X | X | X |
| SA20 | 64Kbytes | 32Kwords | 140000-14FFFF | A0000-A7FFF | 1 | 0 | 1 | 0 | 0 | X | X | X |
| SA21 | 64Kbytes | 32Kwords | 150000-15FFFF | A8000-AFFFF | 1 | 0 | 1 | 0 | 1 | X | X | X |
| SA22 | 64Kbytes | 32Kwords | 160000-16FFFF | B0000-B7FFF | 1 | 0 | 1 | 1 | 0 | X | X | X |
| SA23 | 64Kbytes | 32Kwords | 170000-17FFFF | B8000-BFFFF | 1 | 0 | 1 | 1 | 1 | X | X | X |
| SA24 | 64Kbytes | 32Kwords | 180000-18FFFF | C0000-C7FFF | 1 | 1 | 0 | 0 | 0 | X | X | X |
| SA25 | 64Kbytes | 32Kwords | 190000-19FFFF | C8000-CFFFF | 1 | 1 | 0 | 0 | 1 | X | X | X |
| SA26 | 64Kbytes | 32Kwords | 1A0000-1AFFFF | D0000-D7FFF | 1 | 1 | 0 | 1 | 0 | X | X | X |
| SA27 | 64Kbytes | 32Kwords | 1B0000-1BFFFF | D8000-DFFFF | 1 | 1 | 0 | 1 | 1 | X | X | X |
| SA28 | 64Kbytes | 32Kwords | 1C0000-1CFFFF | E0000-E7FFF | 1 | 1 | 1 | 0 | 0 | X | X | X |
| SA29 | 64Kbytes | 32Kwords | 1D0000-1DFFFF | E8000-EFFFF | 1 | 1 | 1 | 0 | 1 | X | X | X |
| SA30 | 64Kbytes | 32Kwords | 1E0000-1EFFFF | F0000-F7FFF | 1 | 1 | 1 | 1 | 0 | X | X | X |
| SA31 | 32Kbytes | 16Kwords | 1F0000-1F7FFF | F8000-FBFFF | 1 | 1 | 1 | 1 | 1 | 0 | X | X |
| SA32 | 8Kbytes | 4Kwords | 1F8000-1F9FFF | FC000-FCFFF | 1 | 1 | 1 | 1 | 1 | 1 | 0 | 0 |
| SA33 | 8Kbytes | 4Kwords | 1FA000-1FBFFF | FD000-FDFFF | 1 | 1 | 1 | 1 | 1 | 1 | 0 | 1 |
| SA34 | 16Kbytes | 8Kwords | 1FC000-1FFFFF | FE000-FFFFF | 1 | 1 | 1 | 1 | 1 | 1 | 1 | X |

MX29LV160CB SECTOR ARCHITECTURE

| Sector | Sector Size | | Address range | | Sector Address | | | | | | | |
|--------|-------------|-----------|----------------|-----------------|----------------|-----|-----|-----|-----|-----|-----|-----|
| | Byte Mode | Word Mode | Byte Mode (x8) | Word Mode (x16) | A19 | A18 | A17 | A16 | A15 | A14 | A13 | A12 |
| SA0 | 16Kbytes | 8Kwords | 000000-003FFF | 00000-01FFF | 0 | 0 | 0 | 0 | 0 | 0 | 0 | X |
| SA1 | 8Kbytes | 4Kwords | 004000-005FFF | 02000-02FFF | 0 | 0 | 0 | 0 | 0 | 0 | 1 | 0 |
| SA2 | 8Kbytes | 4Kwords | 006000-007FFF | 03000-03FFF | 0 | 0 | 0 | 0 | 0 | 0 | 1 | 1 |
| SA3 | 32Kbytes | 16Kwords | 008000-00FFFF | 04000-07FFF | 0 | 0 | 0 | 0 | 0 | 1 | X | X |
| SA4 | 64Kbytes | 32Kwords | 010000-01FFFF | 08000-0FFFF | 0 | 0 | 0 | 0 | 1 | X | X | X |
| SA5 | 64Kbytes | 32Kwords | 020000-02FFFF | 10000-17FFF | 0 | 0 | 0 | 1 | 0 | X | X | X |
| SA6 | 64Kbytes | 32Kwords | 030000-03FFFF | 18000-1FFFF | 0 | 0 | 0 | 1 | 1 | X | X | X |
| SA7 | 64Kbytes | 32Kwords | 040000-04FFFF | 20000-27FFF | 0 | 0 | 1 | 0 | 0 | X | X | X |
| SA8 | 64Kbytes | 32Kwords | 050000-05FFFF | 28000-2FFFF | 0 | 0 | 1 | 0 | 1 | X | X | X |
| SA9 | 64Kbytes | 32Kwords | 060000-06FFFF | 30000-37FFF | 0 | 0 | 1 | 1 | 0 | X | X | X |
| SA10 | 64Kbytes | 32Kwords | 070000-07FFFF | 38000-3FFFF | 0 | 0 | 1 | 1 | 1 | X | X | X |
| SA11 | 64Kbytes | 32Kwords | 080000-08FFFF | 40000-47FFF | 0 | 1 | 0 | 0 | 0 | X | X | X |
| SA12 | 64Kbytes | 32Kwords | 090000-09FFFF | 48000-4FFFF | 0 | 1 | 0 | 0 | 1 | X | X | X |
| SA13 | 64Kbytes | 32Kwords | 0A0000-0AFFFF | 50000-57FFF | 0 | 1 | 0 | 1 | 0 | X | X | X |
| SA14 | 64Kbytes | 32Kwords | 0B0000-0BFFFF | 58000-5FFFF | 0 | 1 | 0 | 1 | 1 | X | X | X |
| SA15 | 64Kbytes | 32Kwords | 0C0000-0CFFFF | 60000-67FFF | 0 | 1 | 1 | 0 | 0 | X | X | X |
| SA16 | 64Kbytes | 32Kwords | 0D0000-0DFFFF | 68000-6FFFF | 0 | 1 | 1 | 0 | 1 | X | X | X |
| SA17 | 64Kbytes | 32Kwords | 0E0000-0EFFFF | 70000-77FFF | 0 | 1 | 1 | 1 | 0 | X | X | X |
| SA18 | 64Kbytes | 32Kwords | 0F0000-0FFFFF | 78000-7FFFF | 0 | 1 | 1 | 1 | 1 | X | X | X |
| SA19 | 64Kbytes | 32Kwords | 100000-10FFFF | 80000-87FFF | 1 | 0 | 0 | 0 | 0 | X | X | X |
| SA20 | 64Kbytes | 32Kwords | 110000-11FFFF | 88000-8FFFF | 1 | 0 | 0 | 0 | 1 | X | X | X |
| SA21 | 64Kbytes | 32Kwords | 120000-12FFFF | 90000-97FFF | 1 | 0 | 0 | 1 | 0 | X | X | X |
| SA22 | 64Kbytes | 32Kwords | 130000-13FFFF | 98000-9FFFF | 1 | 0 | 0 | 1 | 1 | X | X | X |
| SA23 | 64Kbytes | 32Kwords | 140000-14FFFF | A0000-A7FFF | 1 | 0 | 1 | 0 | 0 | X | X | X |
| SA24 | 64Kbytes | 32Kwords | 150000-15FFFF | A8000-AFFFF | 1 | 0 | 1 | 0 | 1 | X | X | X |
| SA25 | 64Kbytes | 32Kwords | 160000-16FFFF | B0000-B7FFF | 1 | 0 | 1 | 1 | 0 | X | X | X |
| SA26 | 64Kbytes | 32Kwords | 170000-17FFFF | B8000-BFFFF | 1 | 0 | 1 | 1 | 1 | X | X | X |
| SA27 | 64Kbytes | 32Kwords | 180000-18FFFF | C0000-C7FFF | 1 | 1 | 0 | 0 | 0 | X | X | X |
| SA28 | 64Kbytes | 32Kwords | 190000-19FFFF | C8000-CFFFF | 1 | 1 | 0 | 0 | 1 | X | X | X |
| SA29 | 64Kbytes | 32Kwords | 1A0000-1AFFFF | D0000-D7FFF | 1 | 1 | 0 | 1 | 0 | X | X | X |
| SA30 | 64Kbytes | 32Kwords | 1B0000-1BFFFF | D8000-DFFFF | 1 | 1 | 0 | 1 | 1 | X | X | X |
| SA31 | 64Kbytes | 32Kwords | 1C0000-1CFFFF | E0000-E7FFF | 1 | 1 | 1 | 0 | 0 | X | X | X |
| SA32 | 64Kbytes | 32Kwords | 1D0000-1DFFFF | E8000-EFFFF | 1 | 1 | 1 | 0 | 1 | X | X | X |
| SA33 | 64Kbytes | 32Kwords | 1E0000-1EFFFF | F0000-FFFFF | 1 | 1 | 1 | 1 | 0 | X | X | X |
| SA34 | 64Kbytes | 32Kwords | 1F0000-1FFFFF | F8000-FFFFF | 1 | 1 | 1 | 1 | 1 | X | X | X |

Table 2. BUS OPERATION--1

| Mode Select | RE-SET# | CE# | WE# | OE# | Address | Data (I/O) Q0~Q7 | Byte# | |
|----------------------------|--------------|--------------|-----|-----|--|---------------------|----------------------|-------|
| | | | | | | | Vil | Vih |
| | | | | | | | Data (I/O) Q8~Q15 | |
| Device Reset | L | X | X | X | X | HighZ | HighZ | HighZ |
| Standby Mode | Vcc± 0.3V | Vcc± 0.3V | X | X | X | HighZ | HighZ | HighZ |
| Output Disable | H | L | H | H | X | HighZ | HighZ | HighZ |
| Read Mode | H | L | H | L | AIN | DOUT | Q8-Q14= | DOUT |
| Write | H | L | L | H | AIN | DIN | HighZ | DIN |
| Temporary Sector Unprotect | Vhv | X | X | X | AIN | DIN | HighZ | DIN |
| Sector Protect | Vhv | L | L | H | Sector Address, A6=L, A1=H, A0=L | DIN, DOUT | X | X |
| Chip Unprotect | Vhv | L | L | H | Sector Address, A6=H, A1=H, A0=L | DIN, DOUT | X | X |

Note:

- Q0~Q15 are input (DIN) or output (DOUT) pins according to the requests of command sequence, sector protection, or data polling algorithm.
- In Word Mode (Byte#=Vih), the addresses are AM to A0.
In Byte Mode (Byte#=Vil), the addresses are AM to A-1 (Q15).
- AM: MSB of address.

BUS OPERATION--2

| Item | Control Input | | | AM | A11 | | A8 | | A5 | | | | |
|-----------------------------------|---------------|-----|-----|-----------|-----------|-----------------|----------|----|----------|----|----|--------------------|-----------------------|
| | CE# | WE# | OE# | to A12 | to A10 | A9 | to A7 | A6 | to A2 | A1 | A0 | Q0~Q7 | Q8~Q15 |
| Sector Lock Status Verification | L | H | L | SA | x | V _{hv} | x | L | x | H | L | 01h or 00h (Note1) | x |
| Read Silicon ID Manufacturer Code | L | H | L | x | x | V _{hv} | x | L | x | L | L | C2H | x |
| Read Silicon ID MX29LV400CT | L | H | L | x | x | V _{hv} | x | L | x | L | H | B9H | 22h(Word) x (Byte) |
| Read Silicon ID MX29LV400CB | L | H | L | x | x | V _{hv} | x | L | x | L | H | BAH | 22h(Word) x (Byte) |
| Read Silicon ID MX29LV800CT | L | H | L | x | x | V _{hv} | x | L | x | L | H | DAH | 22h(Word) x (Byte) |
| Read Silicon ID MX29LV800CB | L | H | L | x | x | V _{hv} | x | L | x | L | H | 5BH | 22h(Word) x (Byte) |
| Read Silicon ID MX29LV160CT | L | H | L | x | x | V _{hv} | x | L | x | L | H | C4H | 22h(Word) x (Byte) |
| Read Silicon ID MX29LV160CB | L | H | L | x | x | V _{hv} | x | L | x | L | H | 49H | 22h(Word) x (Byte) |

Notes:

1. Sector unprotected code:00h. Sector protected code:01h.
2. AM: MSB of address.

WRITE COMMANDS/COMMAND SEQUENCES

To write a command to the device, system must drive WE# and CE# to Vil, and OE# to Vih. In a command cycle, all address are latched at the later falling edge of WE#, and all data are latched at the earlier rising edge of WE#.

Figure 1 illustrates the AC timing waveform of a write command, and Table 3 defines all the valid command sets of the device. System is not allowed to write invalid commands not defined in this datasheet. Writing an invalid command will bring the device to an undefined state.

REQUIREMENTS FOR READING ARRAY DATA

Read array action is to read the data stored in the array. While the memory device is in powered up or has been reset, it will automatically enter the status of read array. If the microprocessor wants to read the data stored in array, it has to drive CE# (device enable control pin) and OE# (Output control pin) as Vil, and input the address of the data to be read into address pin at the same time. After a period of read cycle (Tce or Taa), the data being read out will be displayed on output pin for microprocessor to access. If CE# or OE# is Vih, the output will be in tri-state, and there will be no data displayed on output pin at all.

After the memory device completes embedded operation (automatic Erase or Program), it will automatically return to the status of read array, and the device can read the data in any address in the array. In the process of erasing, if the device receives the Erase suspend command, erase operation will be stopped temporarily after a period of time no more than Tready1 and the device will return to the status of read array. At this time, the device can read the data stored in any address except the sector being erased in the array. In the status of erase suspend, if user wants to read the data in the sectors being erased, the device will output status data onto the output. Similarly, if program command is issued after erase suspend, after program operation is completed, system can still read array data in any address except the sectors to be erased

The device needs to issue reset command to enable read array operation again in order to arbitrarily read the data in the array in the following two situations:

1. In program or erase operation, the programming or erasing failure causes Q5 to go high.
2. The device is in auto select mode or CFI mode.

In the two situations above, if reset command is not issued, the device is not in read array mode and system must issue reset command before reading array data.

RESET# OPERATION

Driving RESET# pin low for a period more than T_{rp} will reset the device back to read mode. If the device is in program or erase operation, the reset operation will take at most a period of T_{ready1} for the device to return to read array mode. Before the device returns to read array mode, the RY/BY# pin remains low (busy status).

When RESET# pin is held at $GND \pm 0.3V$, the device consumes standby current (I_{sb}). However, device draws larger current if RESET# pin is held at V_{il} but not within $GND \pm 0.3V$.

It is recommended that the system to tie its reset signal to RESET# pin of flash memory, so that the flash memory will be reset during system reset and allows system to read boot code from flash memory.

SECTOR PROTECT OPERATION

When a sector is protected, program or erase operation will be disabled on that protected sector. MX29LV400C/MX29LV800C/MX29LV160C T/B provides two methods for sector protection.

Once the sector is protected, the sector remains protected until next chip unprotect, or is temporarily unprotected by asserting RESET# pin at V_{hv} . Refer to temporary sector unprotect operation for further details.

The first method is by applying V_{hv} on RESET# pin. Refer to Figure 12 for timing diagram and Figure 13 for the algorithm for this method.

The other method is asserting V_{hv} on A9 and OE# pins, with A6 and CE# at V_{il} . The protection operation begins at the falling edge of WE# and terminates at the rising edge. Contact Macronix for details.

CHIP UNPROTECT OPERATION

MX29LV400C/MX29LV800C/MX29LV160C T/B provides two methods for chip unprotect. The chip unprotect operation unprotects all sectors within the device. It is recommended to protect all sectors before activating chip unprotect mode. All sectors are unprotected when shipped from the factory.

The first method is by applying V_{hv} on RESET# pin. Refer to Figure 12 for timing diagram and Figure 13 for algorithm of the operation.

The other method is asserting V_{hv} on A9 and OE# pins, with A6 at V_{ih} and CE# at V_{il} (see Table 2). The unprotect operation begins at the falling edge of WE# and terminates at the rising edge. Contact Macronix for details.

TEMPORARY SECTOR UNPROTECT OPERATION

System can apply RESET# pin at V_{hv} to place the device in temporary unprotect mode. In this mode, previously protected sectors can be programmed or erased just as it is unprotected. The devices returns to normal operation once V_{hv} is removed from RESET# pin and previously protected sectors are again protected.

AUTOMATIC SELECT OPERATION

When the device is in Read array mode, erase-suspended read array mode or CFI mode, user can issue read silicon ID command to enter read silicon ID mode. After entering read silicon ID mode, user can query several silicon IDs continuously and does not need to issue read silicon ID mode again. When A0 is Low, device will output Macronix Manufacture ID C2. When A0 is high, device will output Device ID. In read silicon ID mode, issuing reset command will reset device back to read array mode or erase-suspended read array mode.

Another way to enter read silicon ID is to apply high voltage on A9 pin with CE#, OE#, A6 and A1 at Vil. While the high voltage of A9 pin is discharged, device will automatically leave read silicon ID mode and go back to read array mode or erase-suspended read array mode. When A0 is Low, device will output Macronix Manufacture ID C2. When A0 is high, device will output Device ID.

VERIFY SECTOR PROTECT STATUS OPERATION

MX29LV400C/MX29LV800C/MX29LV160C T/B provides hardware sector protection against Program and Erase operation for protected sectors. The sector protect status can be read through Sector Protect Verify command. This method requires Vhv on A9 pin, Vih on WE# and A1 pins, Vil on CE#, OE#, A6 and A0 pins, and sector address on A12 to Am pins. If the read out data is 01H, the designated sector is protected. Oppositely, if the read out data is 00H, the designated sector is not protected.

DATA PROTECTION

To avoid accidental erasure or programming of the device, the device is automatically reset to read array mode during power up. Besides, only after successful completion of the specified command sets will the device begin its erase or program operation.

Other features to protect the data from accidental alternation are described as followed.

LOW VCC WRITE INHIBIT

The device refuses to accept any write command when Vcc is less than 1.4V. This prevents data from spuriously altered. The device automatically resets itself when Vcc is lower than 1.4V and write cycles are ignored until Vcc is greater than 1.4V. System must provide proper signals on control pins after Vcc is larger than 1.4V to avoid unintentional program or erase operation

WRITE PULSE "GLITCH" PROTECTION

CE#, WE#, OE# pulses shorter than 5ns are treated as glitches and will not be regarded as an effective write cycle.

LOGICAL INHIBIT

A valid write cycle requires both CE# and WE# at Vil with OE# at Vih. Write cycle is ignored when either CE# at Vih, WE# a Vih, or OE# at Vil.



MACRONIX
INTERNATIONAL Co., LTD.

MX29LV400C T/B
MX29LV800C T/B
MX29LV160C T/B

POWER-UP SEQUENCE

Upon power up, MX29LV400C/MX29LV800C/MX29LV160C T/B is placed in read array mode. Furthermore, program or erase operation will begin only after successful completion of specified command sequences.

POWER-UP WRITE INHIBIT

When WE#, CE# is held at V_{il} and OE# is held at V_{ih} during power up, the device ignores the first command on the rising edge of WE#.

POWER SUPPLY DECOUPLING

A 0.1 μ F capacitor should be connected between the Vcc and GND to reduce the noise effect.

TABLE 3. MX29LV400C/MX29LV800C/MX29LV160C T/B COMMAND DEFINITIONS

| Command | Hex | Read Mode | Reset Mode | Automatic Select | | | | | | Program | |
|-------------|------|-----------|------------|------------------|------|-----------|------|-----------------------|-----------------|---------|------|
| | | | | Manufacture ID | | Device ID | | Sector Protect Verify | | | |
| | | | | Word | Byte | Word | Byte | Word | Byte | Word | Byte |
| 1st Bus Cyc | Addr | Addr | XXX | 555 | AAA | 555 | AAA | 555 | AAA | 555 | AAA |
| | Data | Data | F0 | AA | AA | AA | AA | AA | AA | AA | AA |
| 2nd Bus Cyc | Addr | | | 2AA | 555 | 2AA | 555 | 2AA | 555 | 2AA | 555 |
| | Data | | | 55 | 55 | 55 | 55 | 55 | 55 | 55 | 55 |
| 3rd Bus Cyc | Addr | | | 555 | AAA | 555 | AAA | 555 | AAA | 555 | AAA |
| | Data | | | 90 | 90 | 90 | 90 | 90 | 90 | A0 | A0 |
| 4th Bus Cyc | Addr | | | X00 | X00 | X01 | X02 | (Sector) X02 | (Sector) X04 | Addr | Addr |
| | Data | | | C2 | C2 | ID | ID | 00/01 | 00/01 | Data | Data |
| 5th Bus Cyc | Addr | | | | | | | | | | |
| | Data | | | | | | | | | | |
| 6th Bus Cyc | Addr | | | | | | | | | | |
| | Data | | | | | | | | | | |

| Command | Hex | Chip Erase | | Sector Erase | | CFI Read | | Erase Suspend | Erase Resume |
|-------------|------|------------|------|--------------|--------|----------|------|---------------|--------------|
| | | Word | Byte | Word | Byte | Word | Byte | Word/Byte | Word/Byte |
| 1st Bus Cyc | Addr | 555 | AAA | 555 | AAA | 55 | AA | XXX | XXX |
| | Data | AA | AA | AA | AA | 98 | 98 | B0 | 30 |
| 2nd Bus Cyc | Addr | 2AA | 555 | 2AA | 555 | | | | |
| | Data | 55 | 55 | 55 | 55 | | | | |
| 3rd Bus Cyc | Addr | 555 | AAA | 555 | AAA | | | | |
| | Data | 80 | 80 | 80 | 80 | | | | |
| 4th Bus Cyc | Addr | 555 | AAA | 555 | AAA | | | | |
| | Data | AA | AA | AA | AA | | | | |
| 5th Bus Cyc | Addr | 2AA | 555 | 2AA | 555 | | | | |
| | Data | 55 | 55 | 55 | 55 | | | | |
| 6th Bus Cyc | Addr | 555 | AAA | Sector | Sector | | | | |
| | Data | 10 | 10 | 30 | 30 | | | | |

Notes:

1. Device ID : MX29LV400CT: 22B9; MX29LV400CB: 22BA.
MX29LV800CT: 22DA; MX29LV800CB: 225B.
MX29LV160CT: 22C4; MX29LV160CB: 2249.
2. For sector protect verify result, XX00H/00H means sector is not protected, XX01H/01H means sector has been protected.
3. Sector Protect command is valid during V_{hv} at RESET# pin, V_{ih} at A1 pin and V_{il} at A0, A6 pins. The last Bus cyc is for protect verify.
4. It is not allowed to adopt any other code which is not in the above command definition table.

RESET

In the following situations, executing reset command will reset device back to read array mode:

- Among erase command sequence (before the full command set is completed)
- Sector erase time-out period
- Erase fail (while Q5 is high)
- Among program command sequence (before the full command set is completed, erase-suspended program included)
- Program fail (while Q5 is high, and erase-suspended program fail is included)
- Read silicon ID mode
- Sector protect verify
- CFI mode

While device is at the status of program fail or erase fail (Q5 is high), user must issue reset command to reset device back to read array mode. While the device is in read silicon ID mode, sector protect verify or CFI mode, user must issue reset command to reset device back to read array mode.

When the device is in the progress of programming (not program fail) or erasing (not erase fail), device will ignore reset command.

AUTOMATIC SELECT COMMAND SEQUENCE

Automatic Select mode is used to access the manufacturer ID, device ID and to verify whether or not a sector is protected. The automatic select mode has four command cycles. The first two are unlock cycles, and followed by a specific command. The fourth cycle is a normal read cycle, and user can read at any address any number of times without entering another command sequence. The reset command is necessary to exit the Automatic Select mode and back to read array. The following table shows the identification code with corresponding address.

| Read Silicon ID | | Address | Data (Hex) | Representation |
|-----------------------|------|-----------------------|------------|------------------------|
| Manufacturer ID | Word | X00 | 00C2 | |
| | Byte | X00 | C2 | |
| Device ID | Word | X01 | ID | Top/Bottom Boot Sector |
| | Byte | X02 | ID | Top/Bottom Boot Sector |
| Sector Protect Verify | Word | (Sector address) X 02 | 00/01 | Unprotected/protected |
| | Byte | (Sector address) X 04 | 00/01 | Unprotected/protected |

There is an alternative method to that shown in Table 2, which is intended for EPROM programmers and requires V_{hv} on address bit A9.

AUTOMATIC PROGRAMMING

The MX29LV400C/MX29LV800C/MX29LV160C T/B can provide the user program function by the form of Byte-Mode or Word-Mode. As long as the users enter the right cycle defined in the Table.3 (including 2 unlock cycles and A0H), any data user inputs will automatically be programmed into the array.

Once the program function is executed, the internal write state controller will automatically execute the algorithms and timings necessary for program and verification, which includes generating suitable program pulse, verifying whether the threshold voltage of the programmed cell is high enough and repeating the program pulse if any of the cells does not pass verification. Meanwhile, the internal control will prohibit the programming to cells that pass verification while the other cells fail in verification in order to avoid over-programming. With the internal write state controller, the device requires the user to write the program command and data only.

Programming will only change the bit status from "1" to "0". That is to say, it is impossible to convert the bit status from "0" to "1" by programming. Meanwhile, the internal write verification only detects the errors of the "1" that is not successfully programmed to "0".

Any command written to the device during programming will be ignored except hardware reset, which will terminate the program operation after a period of time no more than Tready1. When the embedded program algorithm is complete or the program operation is terminated by hardware reset, the device will return to the reading array data mode.

The typical chip program time at room temperature of the MX29LV400C/MX29LV800C/MX29LV160C T/B is less than 36 seconds.

When the embedded program operation is on going, user can confirm if the embedded operation is finished or not by the following methods:

| Status | Q7 | Q6 | Q5 | RY/BY# ^{*2} |
|---------------------------|-----|---------------|----|----------------------|
| In progress ^{*1} | Q7# | Toggling | 0 | 0 |
| Finished | Q7 | Stop toggling | 0 | 1 |
| Exceed time limit | Q7# | Toggling | 1 | 0 |

*1: The status "in progress" means both program mode and erase-suspended program mode.

*2: RY/BY# is an open drain output pin and should be weakly connected to VDD through a pull-up resistor.

*3: When an attempt is made to program a protected sector, Q7 will output its complement data or Q6 continues to toggle for about 1us or less and the device returns to read array state without programing the data in the protected sector.

CHIP ERASE

Chip Erase is to erase all the data with "1" and "0" as all "1". It needs 6 cycles to write the action in, and the first two cycles are "unlock" cycles, the third one is a configuration cycle, the fourth and fifth are also "unlock" cycles, and the sixth cycle is the chip erase operation.

During chip erasing, all the commands will not be accepted except hardware reset or the working voltage is too low that chip erase will be interrupted. After Chip Erase, the chip will return to the state of Read Array.

When the embedded chip erase operation is on going, user can confirm if the embedded operation is finished or not by the following methods:

| Status | Q7 | Q6 | Q5 | Q2 | RY/BY# |
|-------------------|----|---------------|----|----------|--------|
| In progress | 0 | Toggling | 0 | Toggling | 0 |
| Finished | 1 | Stop toggling | 0 | 1 | 1 |
| Exceed time limit | 0 | Toggling | 1 | Toggling | 0 |

SECTOR ERASE

Sector Erase is to erase all the data in a sector with "1" and "0" as all "1". It requires six command cycles to issue. The first two cycles are "unlock cycles", the third one is a configuration cycle, the fourth and fifth are also "unlock cycles" and the sixth cycle is the sector erase command. After the sector erase command sequence is issued, there is a time-out period of 50us counted internally. During the time-out period, additional sector address and sector erase command can be written multiply. Once user enters another sector erase command, the time-out period of 50us is recounted. If user enters any command other than sector eras or erase suspend during time-out period, the erase command would be aborted and the device is reset to read array condition. The number of sectors could be from one sector to all sectors. After time-out period passing by, additional erase command is not accepted and erase embedded operation begins.

During sector erasing, all commands will not be accepted except hardware reset and erase suspend and user can check the status as chip erase.

When the embedded erase operation is on going, user can confirm if the embedded operation is finished or not by the following methods:

| Status | Q7 | Q6 | Q5 | Q3 | Q2 | RY/BY#*2 |
|-------------------|----|---------------|----|----|----------|----------|
| Time-out period | 0 | Toggling | 0 | 0 | Toggling | 0 |
| In progress | 0 | Toggling | 0 | 1 | Toggling | 0 |
| Finished | 1 | Stop toggling | 0 | 1 | 1 | 1 |
| Exceed time limit | 0 | Toggling | 1 | 1 | Toggling | 0 |

*1: The status Q3 is the time-out period indicator. When Q3=0, the device is in time-out period and is acceptable to another sector address to be erased. When Q3=1, the device is in erase operation and only erase suspend is valid.

*2: RY/BY# is open drain output pin and should be weakly connected to VDD through a pull-up resistor.

*3: When an attempt is made to erase a protected sector, Q7 will output its complement data or Q6 continues to toggle for 100us or less and the device returned to read array status without erasing the data in the protected sector.

SECTOR ERASE SUSPEND

During sector erasure, sector erase suspend is the only valid command. If user issue erase suspend command in the time-out period of sector erasure, device time-out period will be over immediately and the device will go back to erase-suspended read array mode. If user issue erase suspend command during the sector erase is being operated, device will suspend the ongoing erase operation, and after the Tready1 ($\leq 20\mu s$) suspend finishes and the device will enter erase-suspended read array mode. User can judge if the device has finished erase suspend through Q6, Q7, and RY/BY#.

After device has entered erase-suspended read array mode, user can read other sectors not at erase suspend by the speed of Taa; while reading the sector in erase-suspend mode, device will output its status. User can use Q6 and Q2 to judge the sector is erasing or the erase is suspended.

| Status | Q7 | Q6 | Q5 | Q3 | Q2 | RY/BY# |
|---|------|-----------|------|------|--------|--------|
| Erase suspend read in erase suspended sector | 1 | No toggle | 0 | N/A | Toggle | 1 |
| Erase suspend read in non-erase suspended sector | Data | Data | Data | Data | Data | 1 |
| Erase suspend program in non-erase suspended sector | Q7# | Toggle | 0 | N/A | N/A | 0 |

When the device has suspended erasing, user can execute the command sets except sector erase and chip erase, such as read silicon ID, sector protect verify, program, CFI query and erase resume.

SECTOR ERASE RESUME

Sector erase resume command is valid only when the device is in erase suspend state. After erase resume, user can issue another erase suspend command, but there should be a 400uS interval between erase resume and the next erase suspend. If user issue infinite suspend-resume loop, or suspend-resume exceeds 1024 times, the time for erasing will increase.

QUERY COMMAND AND COMMON FLASH INTERFACE (CFI) MODE

MX29LV400C/MX29LV800C/MX29LV160C T/B features CFI mode. Host system can retrieve the operating characteristics, structure and vendor-specified information such as identifying information, memory size, byte/word configuration, operating voltages and timing information of this device by CFI mode. If the system writes the CFI Query command "98h", to address "55h"/"AAh" (depending on Word/Byte mode), the device will enter the CFI Query Mode, any time the device is ready to read array data. The system can read CFI information at the addresses given in Table4.

Once user enters CFI query mode, user can not issue any other commands except reset command. The reset command is required to exit CFI mode and go back to the mode before entering CFI. The system can write the CFI Query command only when the device is in read mode, erase suspend, standby mode or automatic select mode.

Table 4-1. CFI mode: Identification Data Values

(All values in these tables are in hexadecimal)

| Description | Address (h) | Address (h) | Data (h) |
|--|-------------|-------------|----------|
| | (Word Mode) | (Byte Mode) | |
| Query-unique ASCII string "QRY" | 10 | 20 | 0051 |
| | 11 | 22 | 0052 |
| | 12 | 24 | 0059 |
| Primary vendor command set and control interface ID code | 13 | 26 | 0002 |
| | 14 | 28 | 0000 |
| Address for primary algorithm extended query table | 15 | 2A | 0040 |
| | 16 | 2C | 0000 |
| Alternate vendor command set and control interface ID code | 17 | 2E | 0000 |
| | 18 | 30 | 0000 |
| Address for alternate algorithm extended query table | 19 | 32 | 0000 |
| | 1A | 34 | 0000 |

Table 4-2. CFI Mode: System Interface Data Values

| Description | Address (h) | Address (h) | Data (h) |
|--|-------------|-------------|----------|
| | (Word Mode) | (Byte Mode) | |
| Vcc supply minimum program/erase voltage | 1B | 36 | 0027 |
| Vcc supply maximum program/erase voltage | 1C | 38 | 0036 |
| VPP supply minimum program/erase voltage | 1D | 3A | 0000 |
| VPP supply maximum program/erase voltage | 1E | 3C | 0000 |
| Typical timeout per single word/byte write, 2 ⁿ uS | 1F | 3E | 0004 |
| Typical timeout for maximum-size buffer write, 2 ⁿ uS | 20 | 40 | 0000 |
| Typical timeout per individual block erase, 2 ⁿ mS | 21 | 42 | 000A |
| Typical timeout for full chip erase, 2 ⁿ mS | 22 | 44 | 0000 |
| Maximum timeout for word/byte write, 2 ⁿ times typical | 23 | 46 | 0005 |
| Maximum timeout for buffer write, 2 ⁿ times typical | 24 | 48 | 0000 |
| Maximum timeout per individual block erase, 2 ⁿ times typical | 25 | 4A | 0004 |
| Maximum timeout for chip erase, 2 ⁿ times typical | 26 | 4C | 0000 |

Table 4-3. CFI Mode: Device Geometry Data Values

| Description | Address (h) | Address (h) | Data (h) |
|--|-------------|-------------|----------|
| | (Word Mode) | (Byte Mode) | |
| Device size = 2 ⁿ in number of bytes (MX29LV400C) | 27 | 4E | 0013 |
| Device size = 2 ⁿ in number of bytes (MX29LV800C) | 27 | 4E | 0014 |
| Device size = 2 ⁿ in number of bytes (MX29LV160C) | 27 | 4E | 0015 |
| Flash device interface description (02=asynchronous x8/x16) | 28 | 50 | 0002 |
| | 29 | 52 | 0000 |
| Maximum number of bytes in buffer write = 2 ⁿ (not support) | 2A | 54 | 0000 |
| | 2B | 56 | 0000 |
| Number of erase regions within device | 2C | 58 | 0004 |
| Index for Erase Bank Area 1 | 2D | 5A | 0000 |
| [2E,2D] = # of same-size sectors in region 1-1 | 2E | 5C | 0000 |
| [30, 2F] = sector size in multiples of 256-bytes | 2F | 5E | 0040 |
| Index for Erase Bank Area 2 | 30 | 60 | 0000 |
| | 31 | 62 | 0001 |
| | 32 | 64 | 0000 |
| | 33 | 66 | 0020 |
| Index for Erase Bank Area 3 | 34 | 68 | 0000 |
| | 35 | 6A | 0000 |
| | 36 | 6C | 0000 |
| | 37 | 6E | 0080 |
| Index for Erase Bank Area 4 (for MX29LV400C) | 38 | 70 | 0000 |
| | 39 | 72 | 0006 |
| | 39 | 72 | 000E |
| | 39 | 72 | 001E |
| | 3A | 74 | 0000 |
| | 3B | 76 | 0000 |
| Index for Erase Bank Area 4 (for MX29LV800C) | 3C | 78 | 0001 |
| | | | |

Table 4-4. CFI Mode: Primary Vendor-Specific Extended Query Data Values

| Description | Address (h) | Address (h) | Data (h) |
|--|-------------|-------------|----------|
| | (Word Mode) | (Byte Mode) | |
| Query - Primary extended table, unique ASCII string, PRI | 40 | 80 | 0050 |
| | 41 | 82 | 0052 |
| | 42 | 84 | 0049 |
| Major version number, ASCII | 43 | 86 | 0031 |
| Minor version number, ASCII | 44 | 88 | 0030 |
| Unlock recognizes address (0= recognize, 1= don't recognize) | 45 | 8A | 0000 |
| Erase suspend (2= to both read and program) | 46 | 8C | 0002 |
| Sector protect (N= # of sectors/group) | 47 | 8E | 0001 |
| Temporary sector unprotect (1=supported) | 48 | 90 | 0001 |
| Sector protect/Chip unprotect scheme | 49 | 92 | 0004 |
| Simultaneous R/W operation (0=not supported) | 4A | 94 | 0000 |
| Burst mode (0=not supported) | 4B | 96 | 0000 |
| Page mode (0=not supported) | 4C | 98 | 0000 |



ABSOLUTE MAXIMUM STRESS RATINGS

| | |
|---|----------------------|
| Surrounding Temperature with Bias | -65°C to +125°C |
| Storage Temperature | -65°C to +150°C |
| Voltage Range | |
| Vcc | -0.5 V to +4.0 V |
| RESET#, A9 and OE# | -0.5 V to +12.5 V |
| The other pins. | -0.5 V to Vcc +0.5 V |
| Output Short Circuit Current (less than one second) | .200 mA |

Note:

1. Maximum voltage may overshoot to Vcc+2V during transition and for less than 20ns during transitions.
2. Minimum voltage may undershoot to -2V during transition and for less than 20ns during transitions.
3. Applied conditions greater than those listed under "Absolute Maximum Stress Ratings" may cause permanent damage to the device. Exposure to Absolute Maximum Rating conditions for extended periods may affect device reliability. This is a stress rating only and functional operation of the device at these conditions or conditions greater than those defined in the operational sections of this data sheet is not implied.

OPERATING TEMPERATURE AND VOLTAGE

Commercial (C) Grade

Surrounding Temperature (T_A)..... 0° C to +70° C

Industrial (I) Grade

Surrounding Temperature (T_A)..... -40° C to +85° C

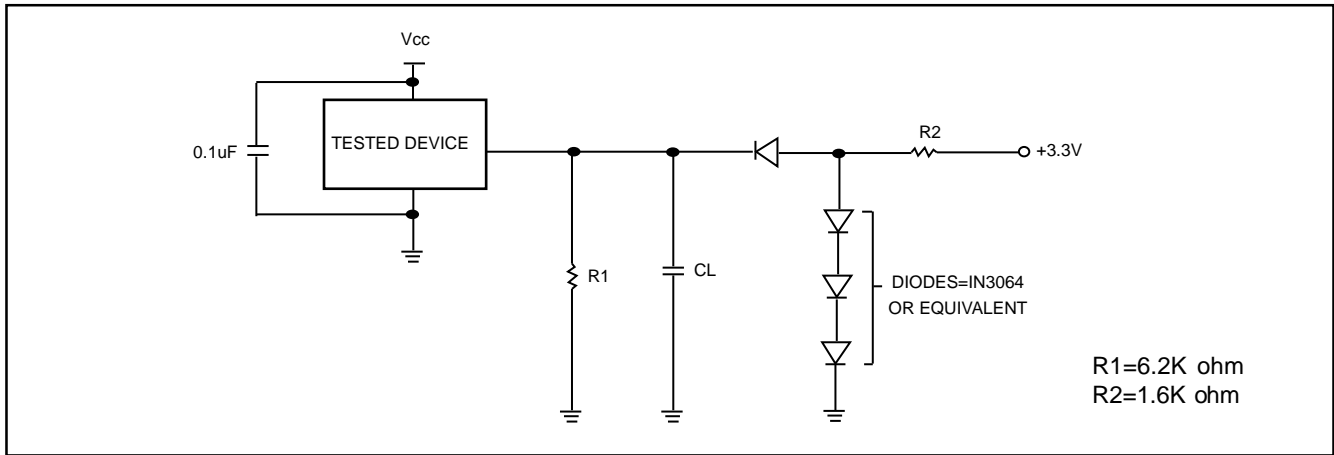
Vcc Supply Voltages

Vcc range..... +2.7 V to 3.6 V

DC CHARACTERISTICS

| Symbol | Description | Min | Typ | Max | Remark |
|-------------------|--|-----------------------|-------|-----------------------|--|
| Iilk | Input Leak | | | ± 1.0uA | |
| Iilk9 | A9 Leak | | | 35uA | A9=12.5V |
| Iolk | Output Leak | | | ± 1.0uA | |
| Icr1 | Read Current(5MHz) | | 7mA | 12mA | CE#=Vil, OE#=Vih |
| Icr2 | Read Current(1MHz) | | 2mA | 4mA | CE#=Vil, OE#=Vih |
| Icw | Write Current | | 15mA | 30mA | CE#=Vil, OE#=Vih, WE#=Vil |
| I _{sb} | Standby Current | | 0.2uA | 5uA | V _{cc} =V _{cc} max, other pin disable |
| I _{sr} | Reset Current | | 0.2uA | 5uA | V _{cc} =V _{cc} max, Reset# enable, other pin disable |
| I _{sb} s | Sleep Mode Current | | 0.2uA | 5uA | |
| Vil | Input Low Voltage | -0.5V | | 0.8V | |
| Vih | Input High Voltage | 0.7xV _{cc} | | V _{cc} +0.3V | |
| V _{hv} | Very High Voltage for hardware Protect/Unprotect/Accelerated Program/Auto Select/Temporary Unprotect | 11.5V | | 12.5V | |
| V _{ol} | Output Low Voltage | | | 0.45V | I _{ol} =4.0mA |
| V _{oh1} | Output High Voltage | 0.85xV _{cc} | | | I _{oh1} =-2mA |
| V _{oh2} | Output High Voltage | V _{cc} -0.4V | | | I _{oh2} =-100uA |

Note: Sleep mode enables the lower power when address remain stable for t_{aa}+30ns.

SWITCHING TEST CIRCUITS

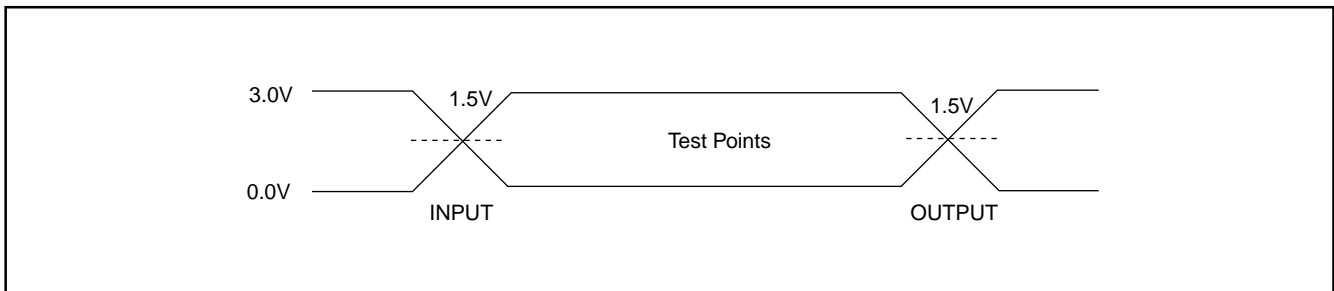
Test Condition

Output Load : 1 TTL gate

Output Load Capacitance, CL : 30pF(70nS)/100pF(90nS)

Rise/Fall Times : 5nS

In/Out reference levels :1.5V

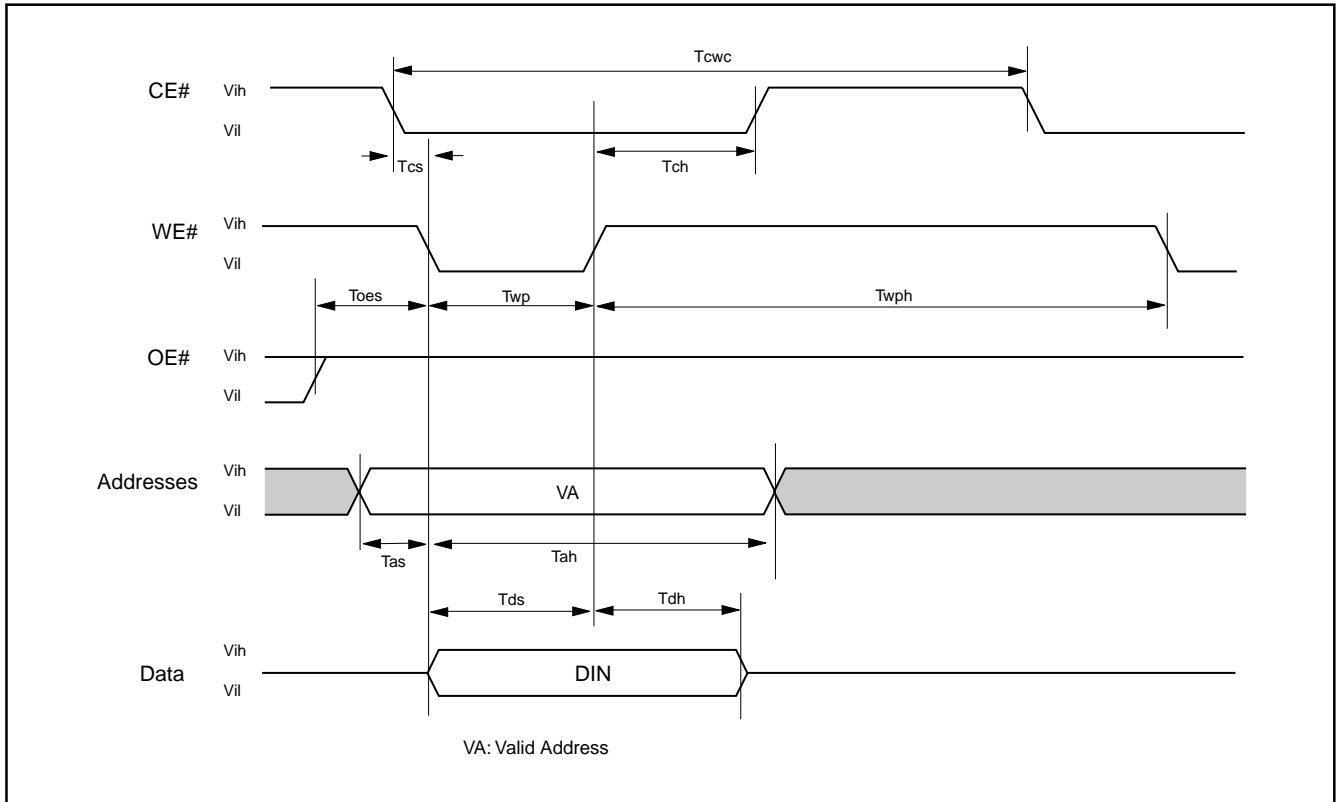
SWITCHING TEST WAVEFORMS

AC CHARACTERISTICS

| Symbol | Description | Min | Typ | Max | Unit |
|--------|---|-------------------------------|-----|-------------------------------|------|
| Taa | Valid data output after address | | | 45/55 ⁽¹⁾ 70/90 | nS |
| Tce | Valid data output after CE# low | | | 45/55 ⁽¹⁾ 70/90 | nS |
| Toe | Valid data output after OE# low | | | 30 | nS |
| Tdf | Data output floating after OE# high | | | 25 | nS |
| Toh | Output hold time from the earliest rising edge of address, CE#, OE# | 0 | | | nS |
| Trc | Read period time | 45/55 ⁽¹⁾ 70/90 | | | nS |
| Twc | Write period time | 70/90 | | | nS |
| Tcwc | Command write period time | 70/90 | | | nS |
| Tas | Address setup time | 0 | | | nS |
| Tah | Address hold time | 45 | | | nS |
| Tds | Data setup time | 35 | | | nS |
| Tdh | Data hold time | 0 | | | nS |
| Tvcs | Vcc setup time | 50 | | | uS |
| Tcs | Chip enable Setup time | 0 | | | nS |
| Tch | Chip enable hold time | 0 | | | nS |
| Toes | Output enable setup time | 0 | | | nS |
| Toeh | Output enable hold time | Read | 0 | | nS |
| Toeh | | Toggle & Data# Polling | 10 | | nS |
| Tws | WE# setup time | 0 | | | nS |
| Twh | WE# hold time | 0 | | | nS |
| Tcep | CE# pulse width | 35 | | | nS |
| Tceph | CE# pulse width high | 30 | | | nS |
| Twp | WE# pulse width | 35 | | | nS |
| Twph | WE# pulse width high | 30 | | | nS |
| Tbusy | Program/Erase active time by RY/BY# | | | 90 | nS |
| Tghwl | Read recover time before write | 0 | | | nS |
| Tghel | Read recover time before write | 0 | | | nS |
| Twhwh1 | Program operation | Byte | 9 | | uS |
| Twhwh1 | Program operation | Word | 11 | | uS |
| Twhwh2 | Sector Erase Operation | | 0.7 | | sec |
| Tbal | Sector Add hold time | | | 50 | uS |

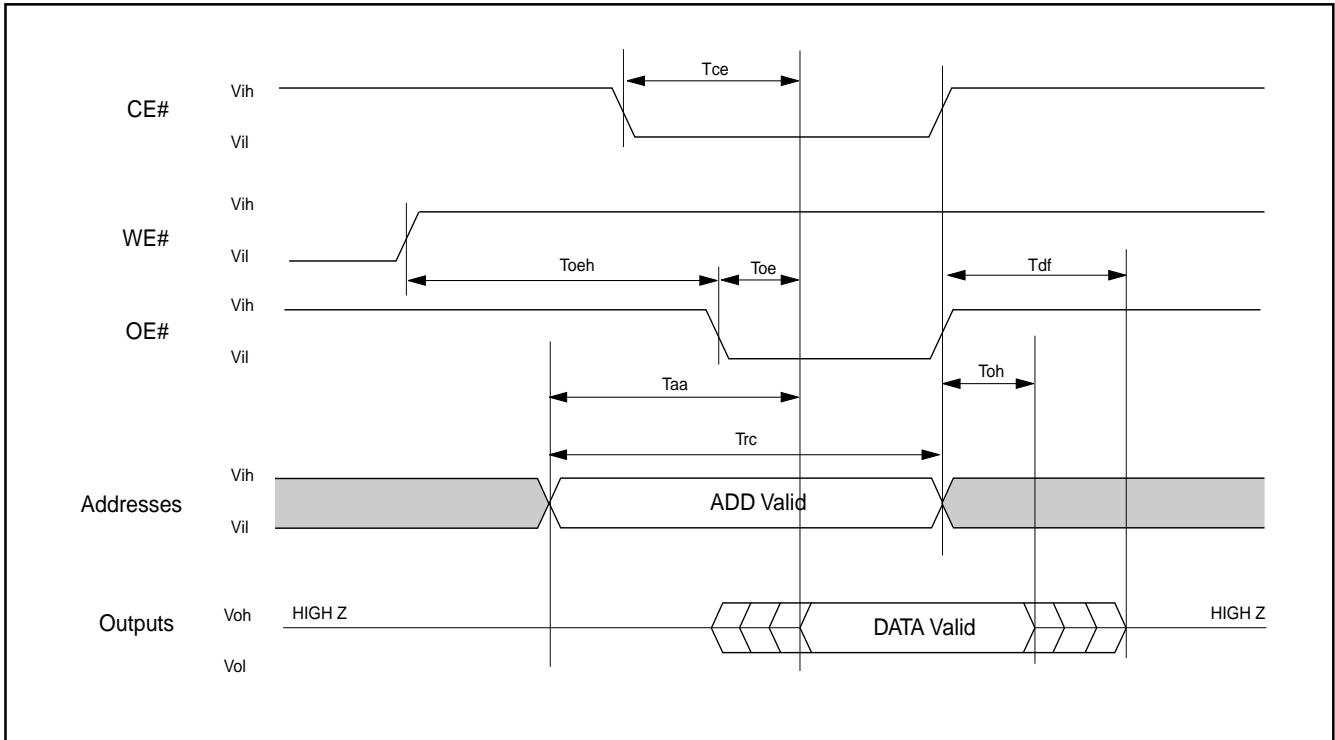
Notes: (1) 45nS only for MX29LV800C-45

Figure 1. COMMAND WRITE OPERATION



READ/RESET OPERATION

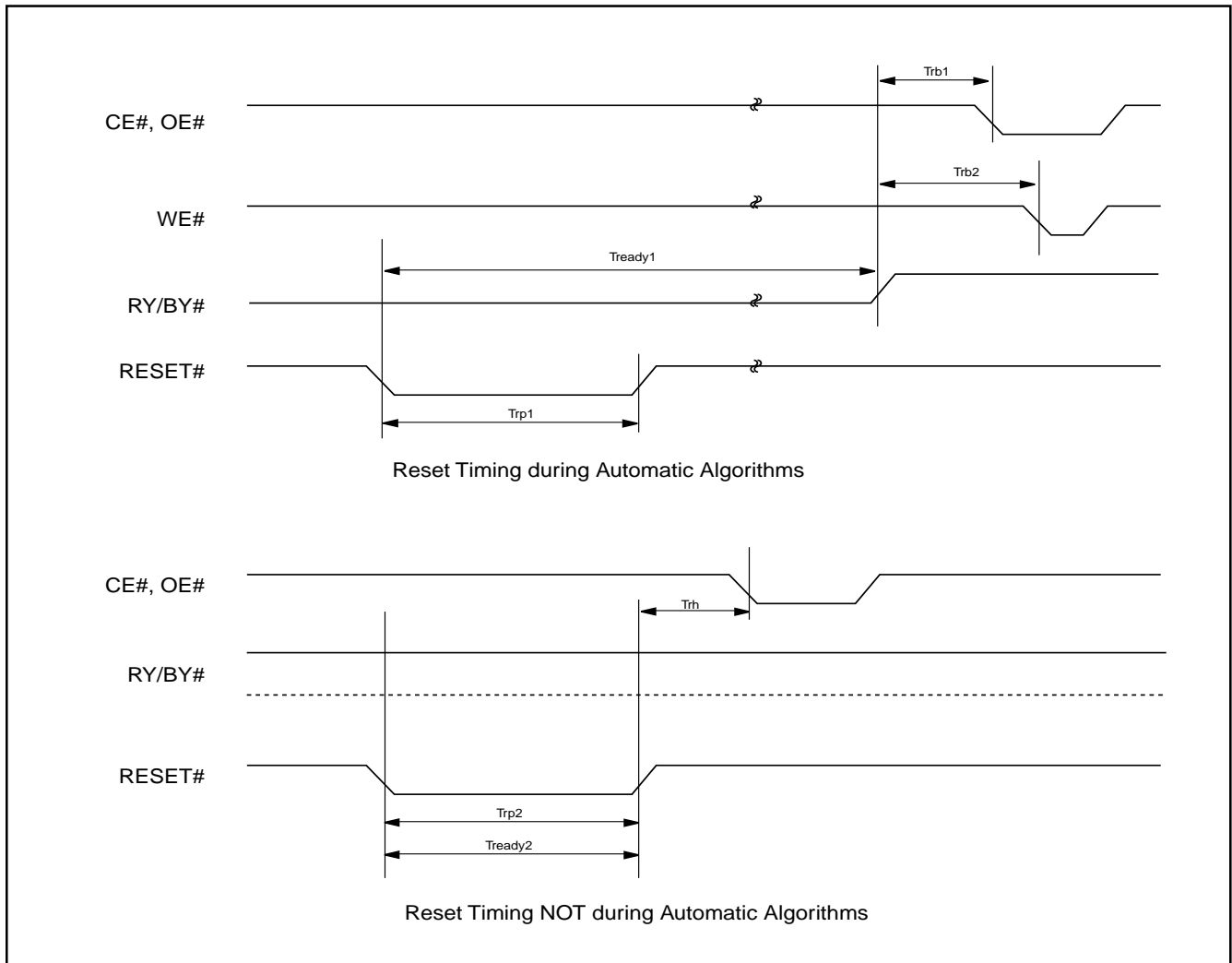
Figure 2. READ TIMING WAVEFORMS



AC CHARACTERISTICS

| Item | Description | Setup | Speed | Unit |
|---------|---|-------|-------|------|
| Trp1 | RESET# Pulse Width (During Automatic Algorithms) | MIN | 500 | nS |
| Trp2 | RESET# Pulse Width (NOT During Automatic Algorithms) | MIN | 500 | nS |
| Trh | RESET# High Time Before Read | MIN | 50 | nS |
| Trb1 | RY/BY# Recovery Time (to CE#, OE# go low) | MIN | 0 | nS |
| Trb2 | RY/BY# Recovery Time (to WE# go low) | MIN | 50 | nS |
| Tready1 | RESET# PIN Low (During Automatic Algorithms) to Read or Write | MAX | 20 | uS |
| Tready2 | RESET# PIN Low (NOT During Automatic Algorithms) to Read or Write | MAX | 500 | nS |

Figure 3. RESET# TIMING WAVEFORM



ERASE/PROGRAM OPERATION

Figure 4. AUTOMATIC CHIP ERASE TIMING WAVEFORM

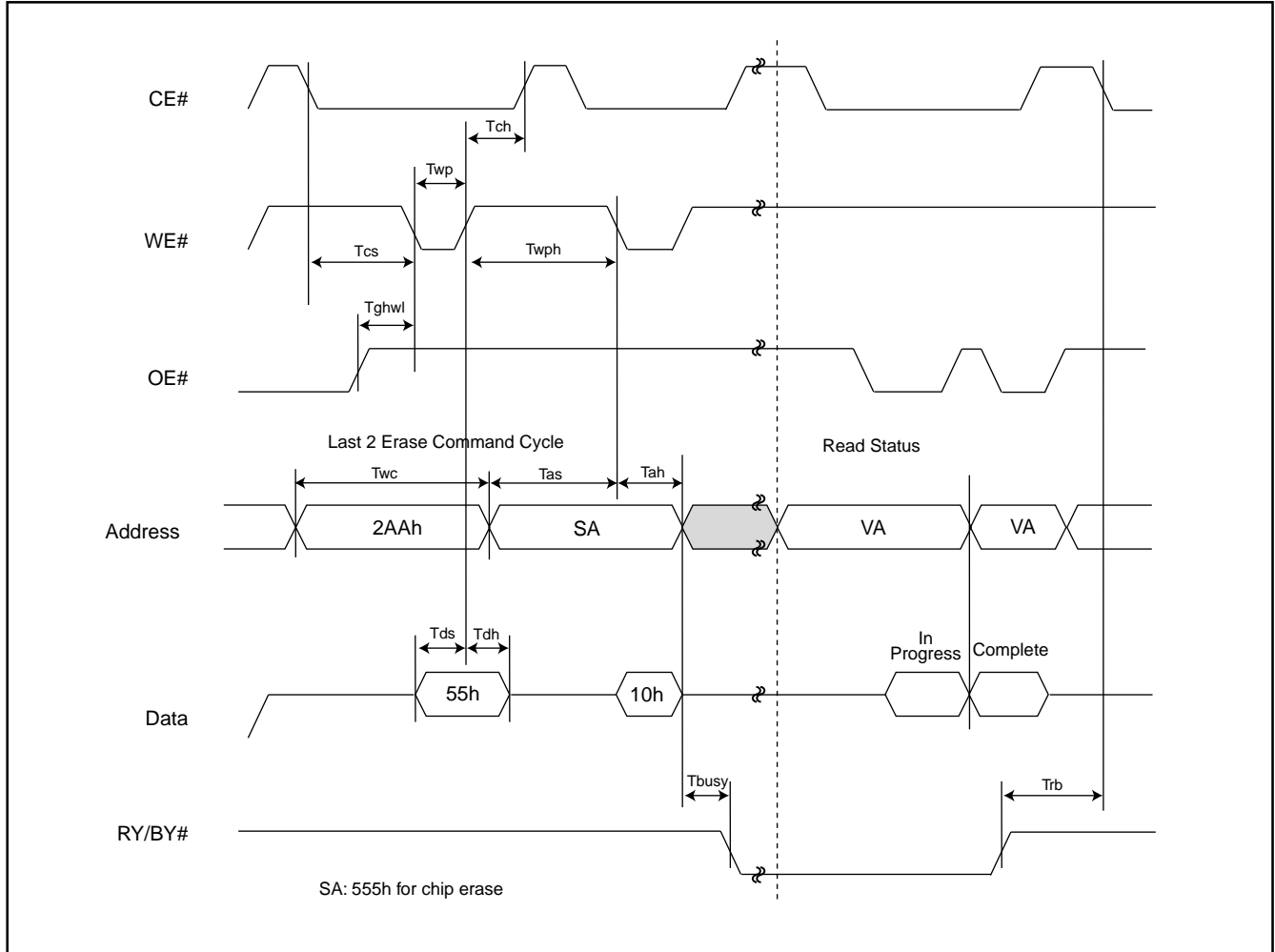


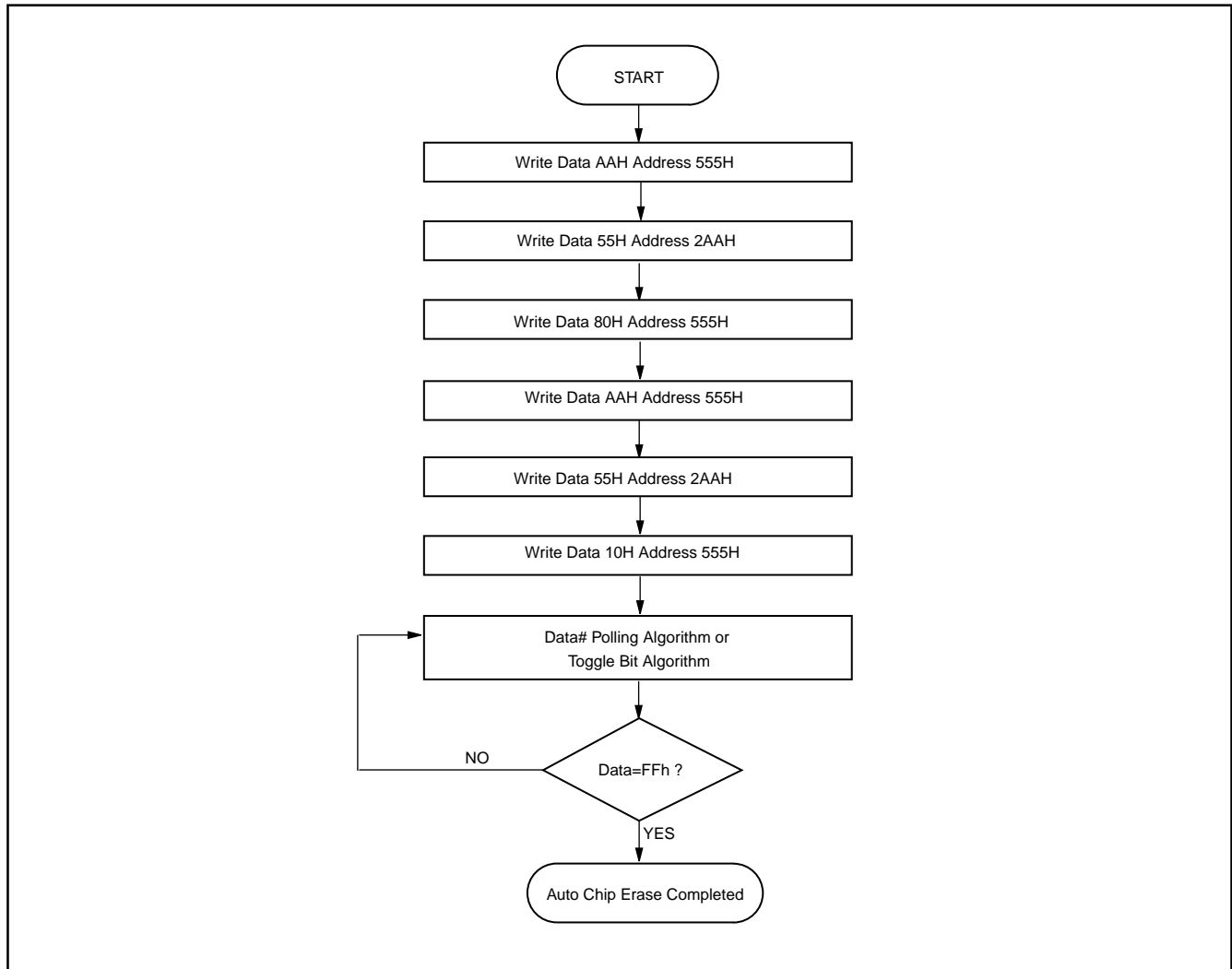
Figure 5. AUTOMATIC CHIP ERASE ALGORITHM FLOWCHART

Figure 6. AUTOMATIC SECTOR ERASE TIMING WAVEFORM

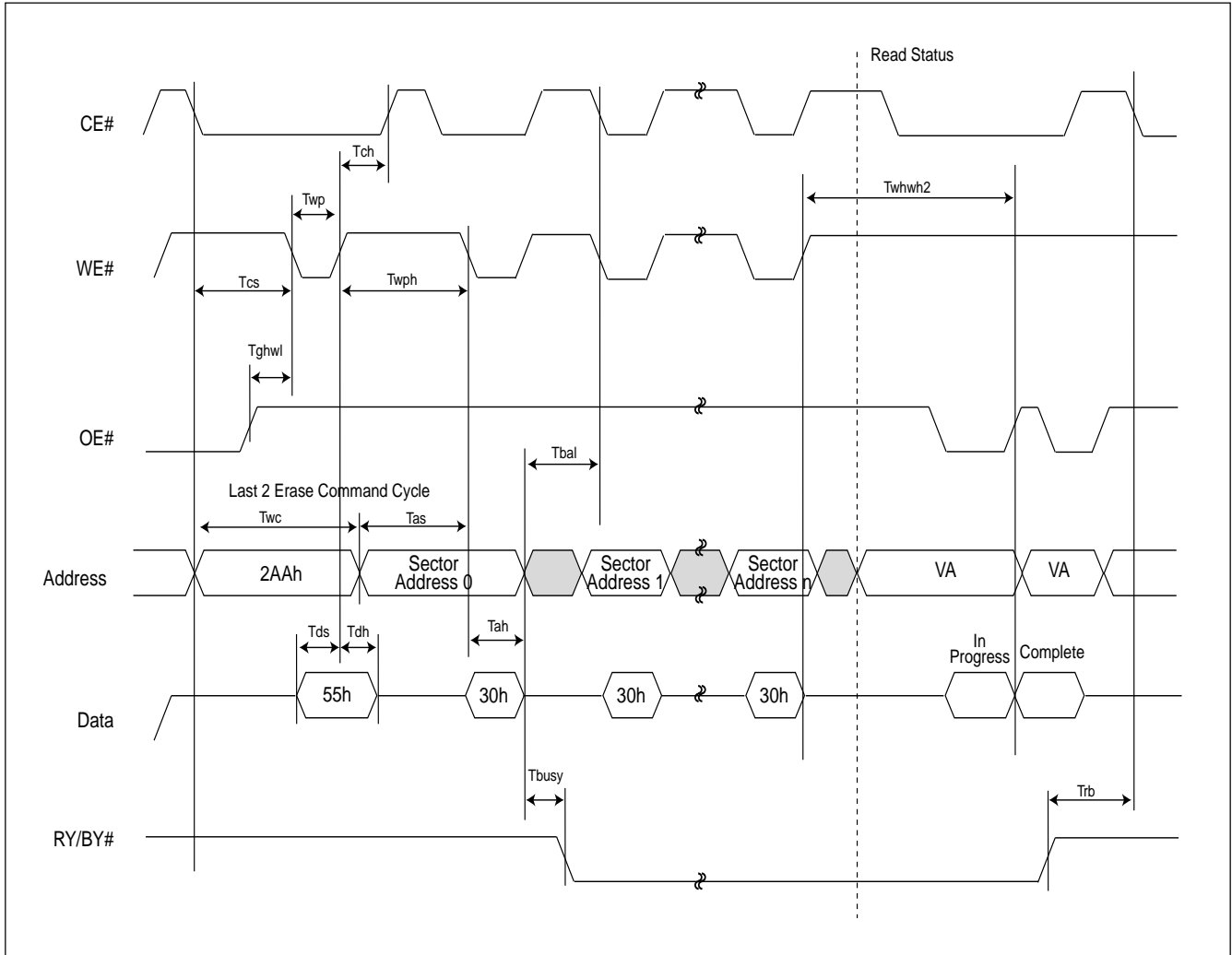


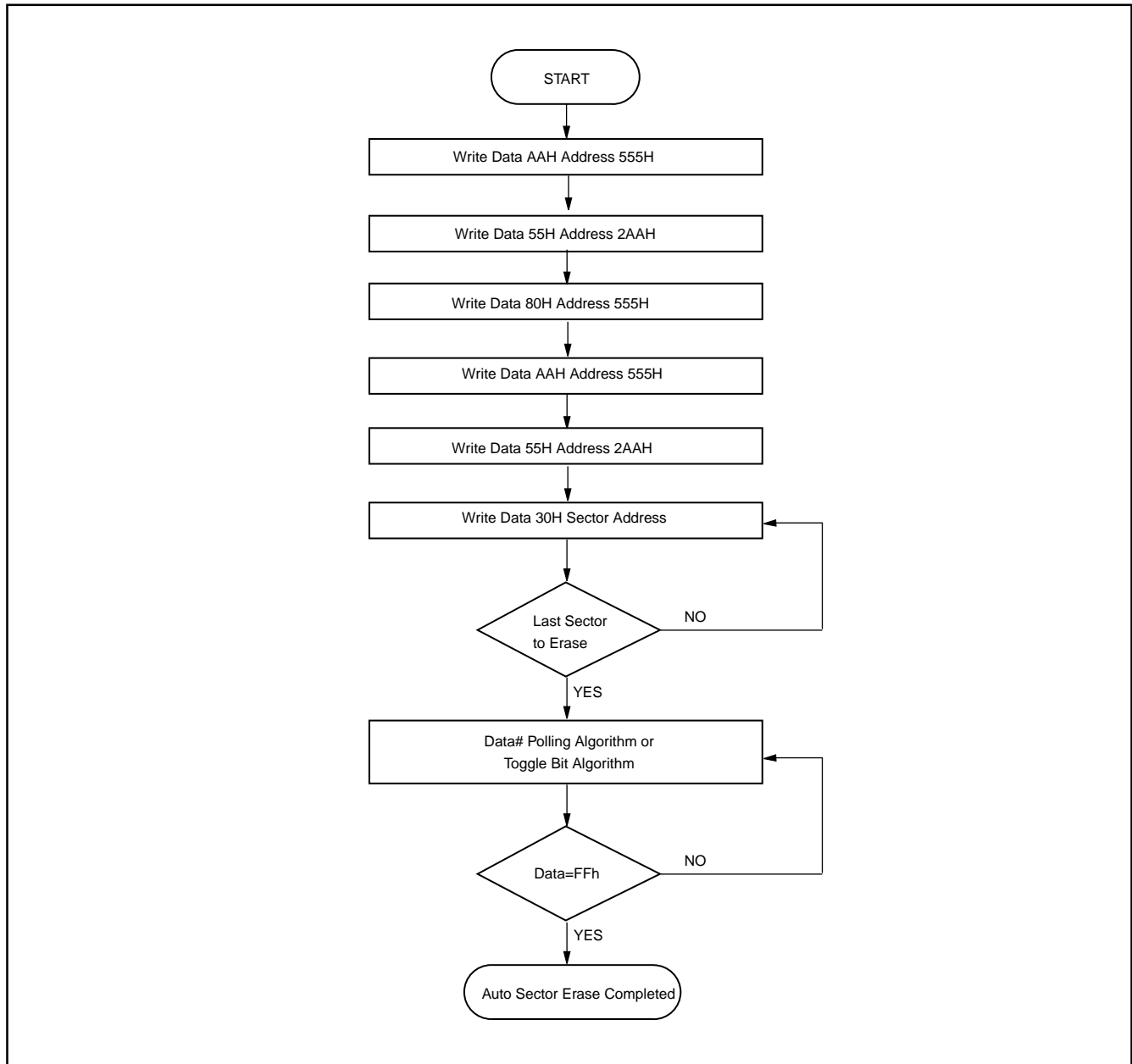
Figure 7. AUTOMATIC SECTOR ERASE ALGORITHM FLOWCHART

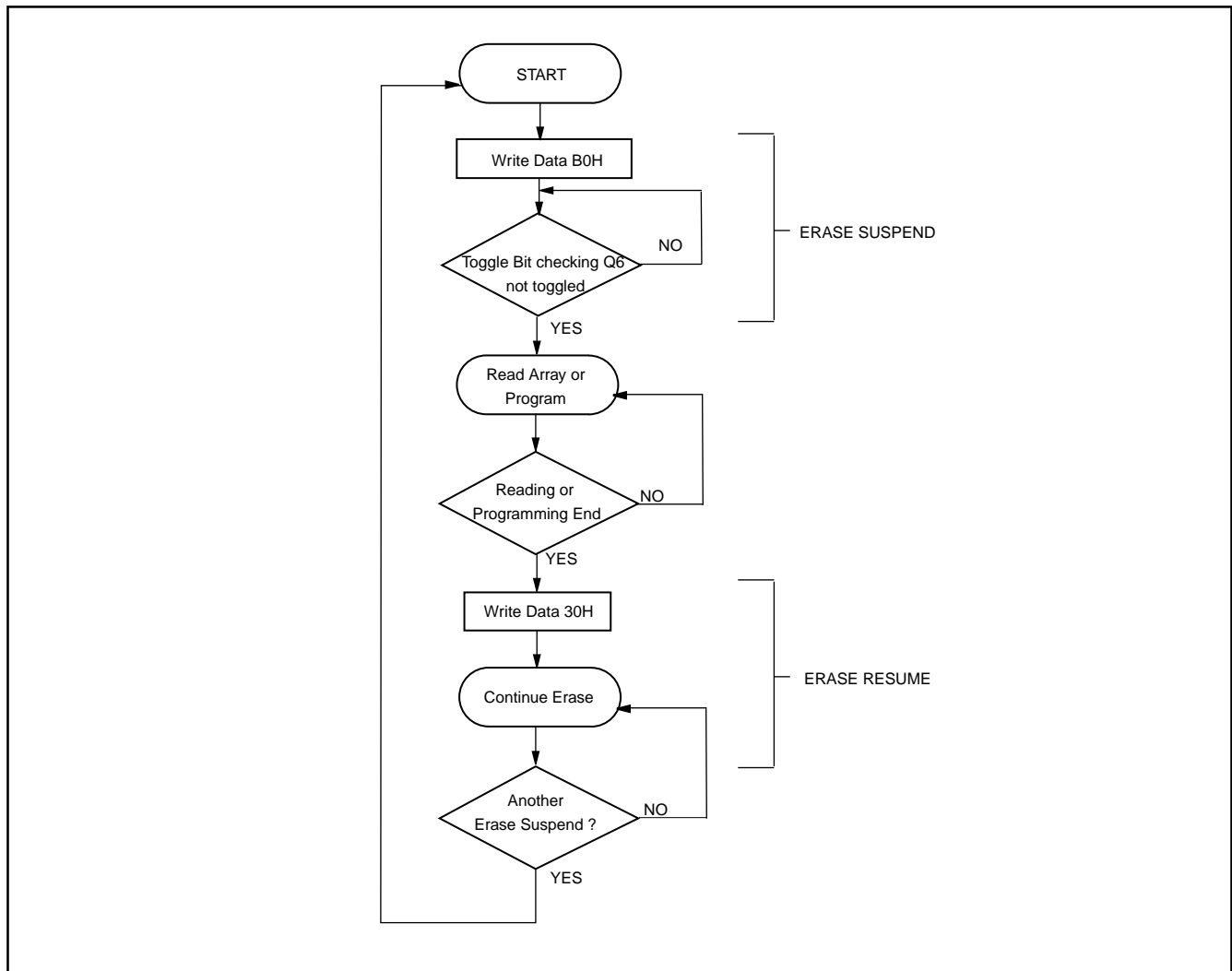
Figure 8. ERASE SUSPEND/RESUME FLOWCHART

Figure 9. AUTOMATIC PROGRAM TIMING WAVEFORMS

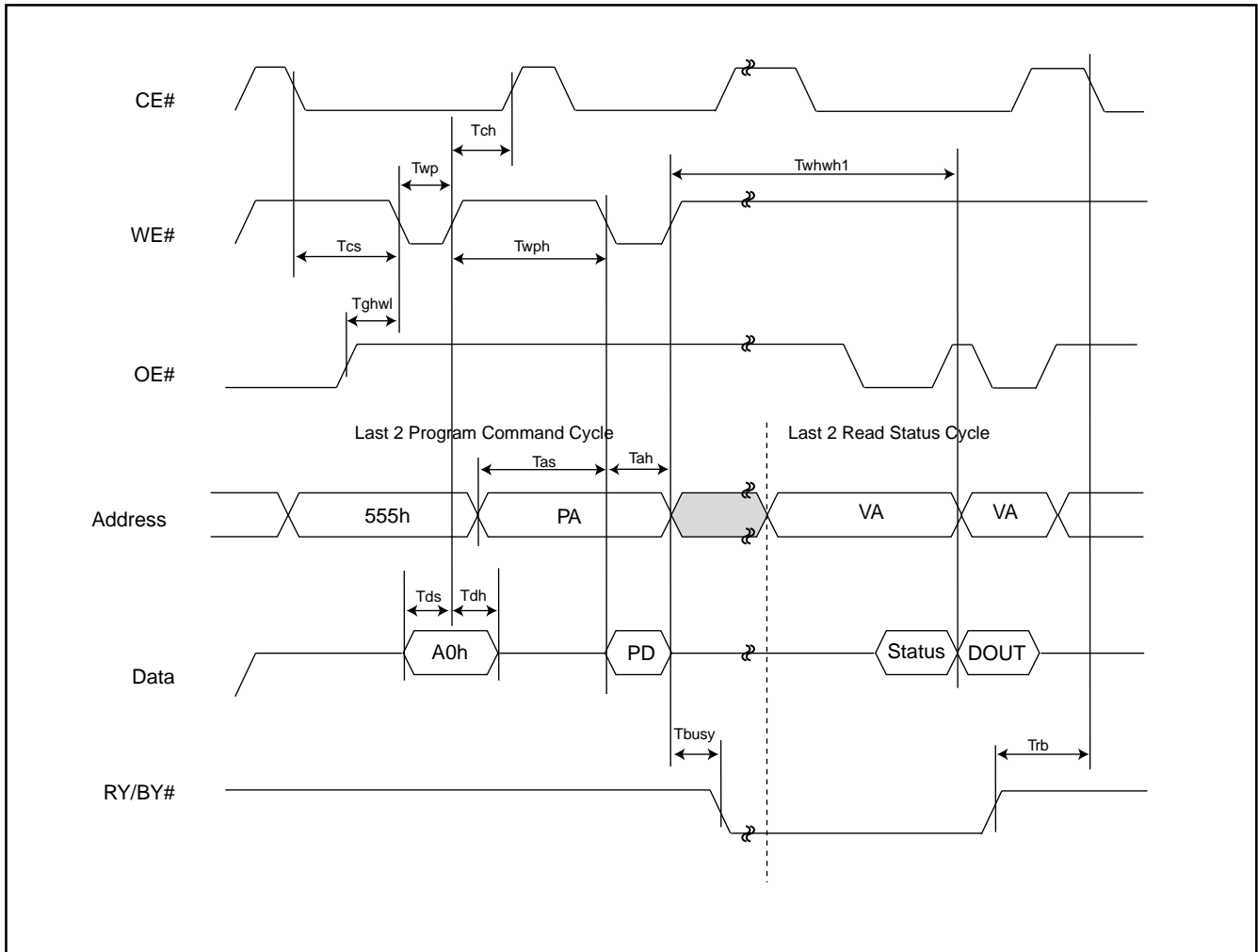


Figure 10. CE# CONTROLLED WRITE TIMING WAVEFORM

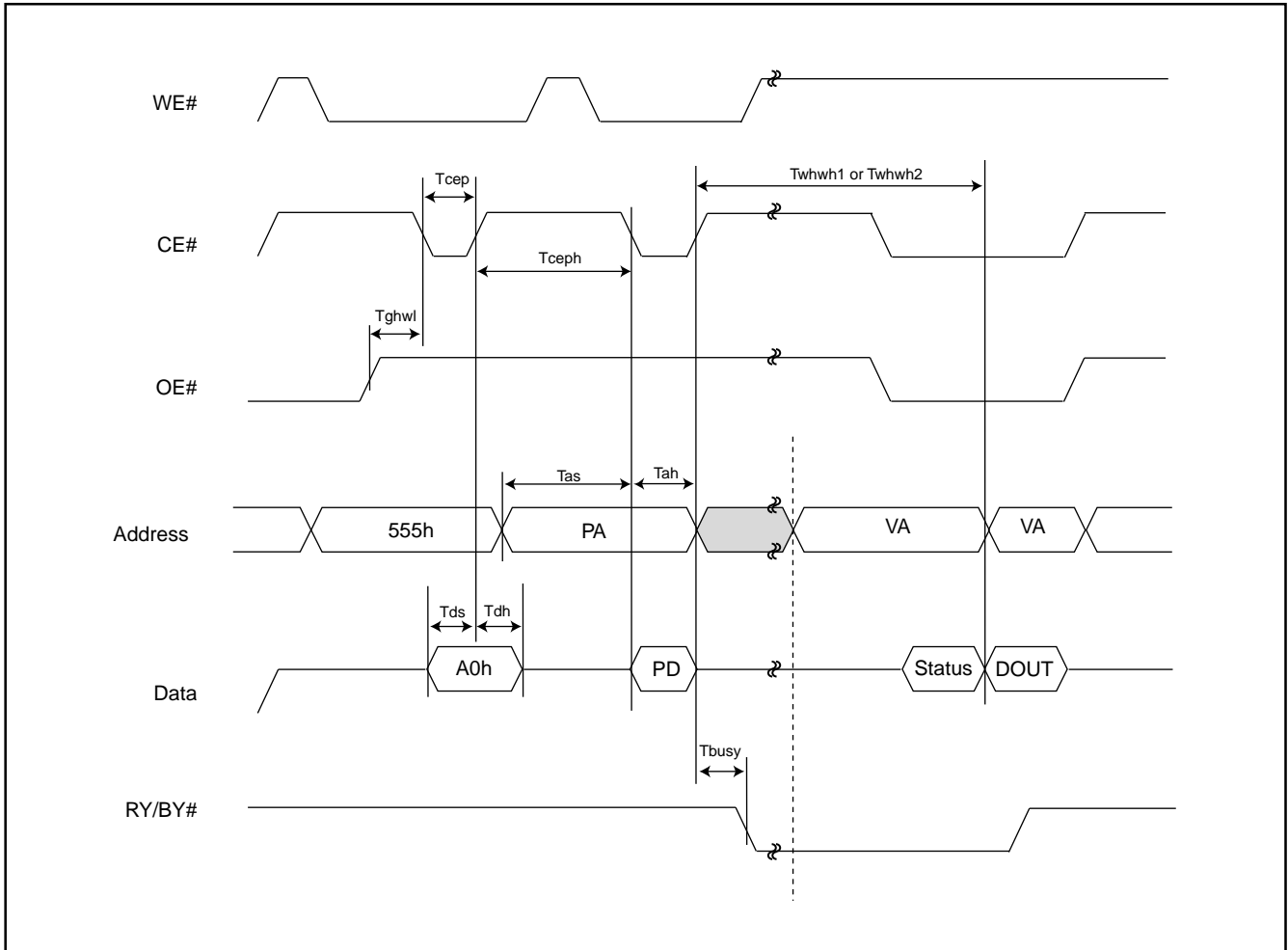
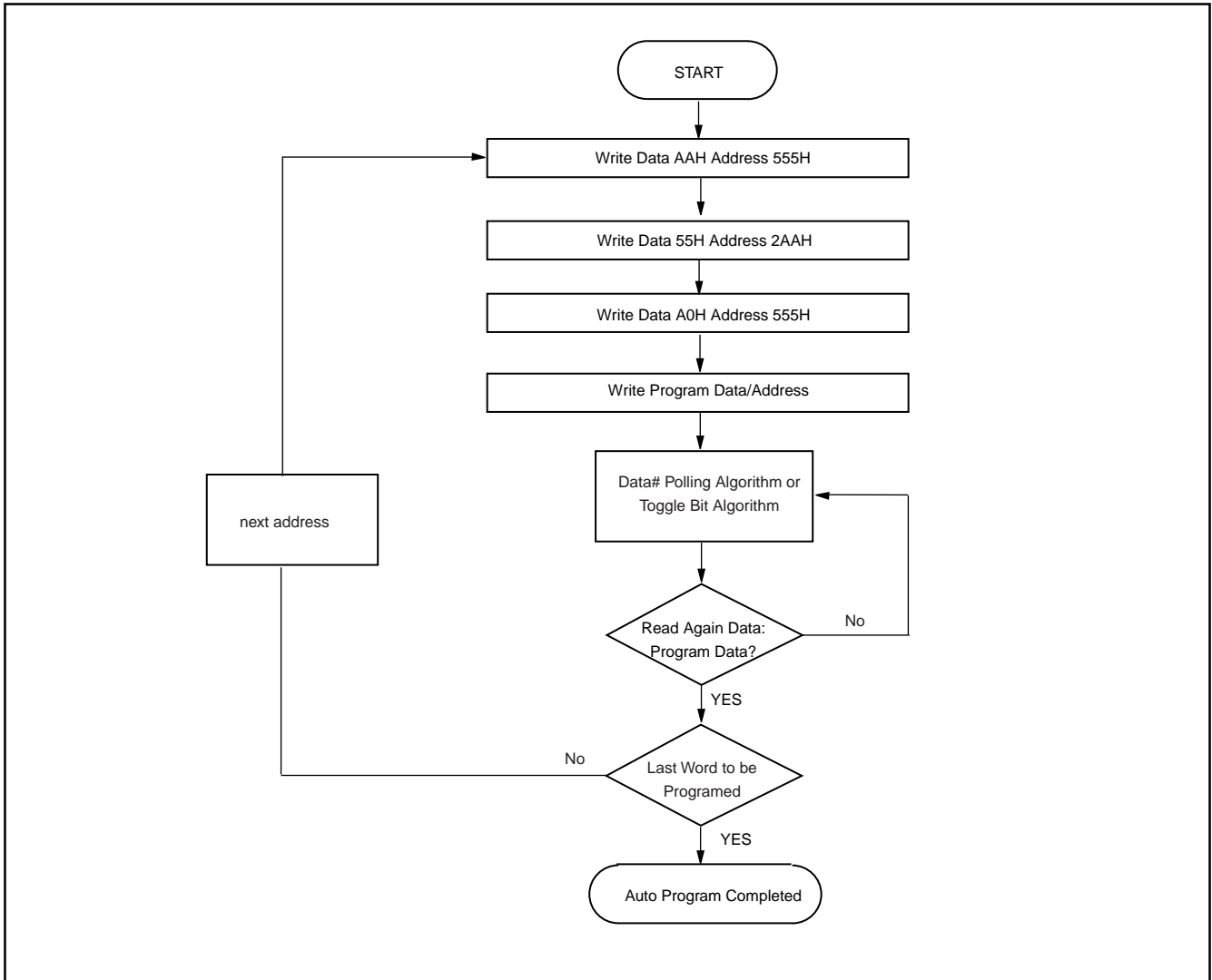


Figure 11. AUTOMATIC PROGRAMMING ALGORITHM FLOWCHART



SECTOR PROTECT/CHIP UNPROTECT

Figure 12. Sector Protect/Chip Unprotect Waveform (RESET# Control)

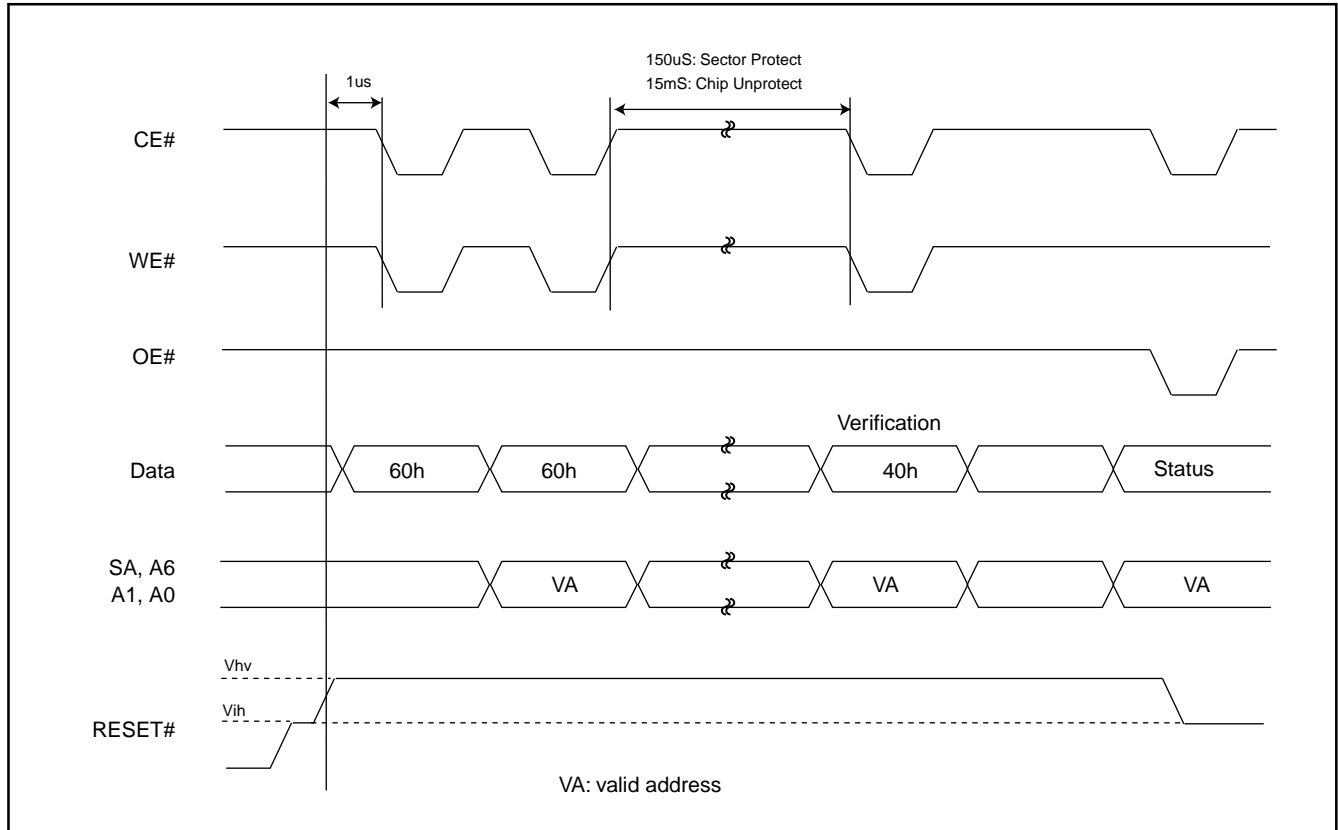


Figure 13-1. IN-SYSTEM SECTOR PROTECT WITH RESET#= V_{hv}

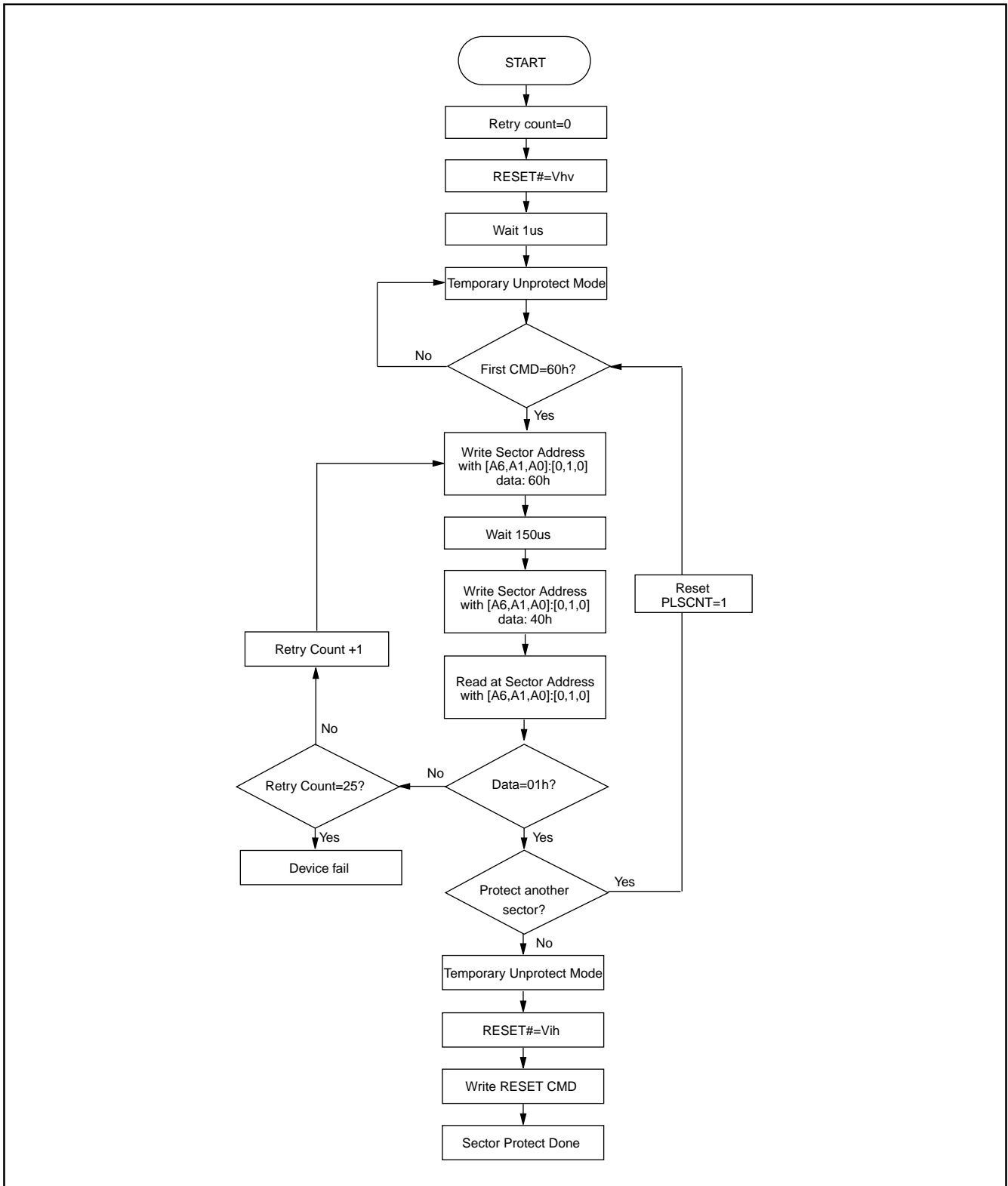


Figure 13-2. CHIP UNPROTECT ALGORITHMS WITH RESET#=Vhv

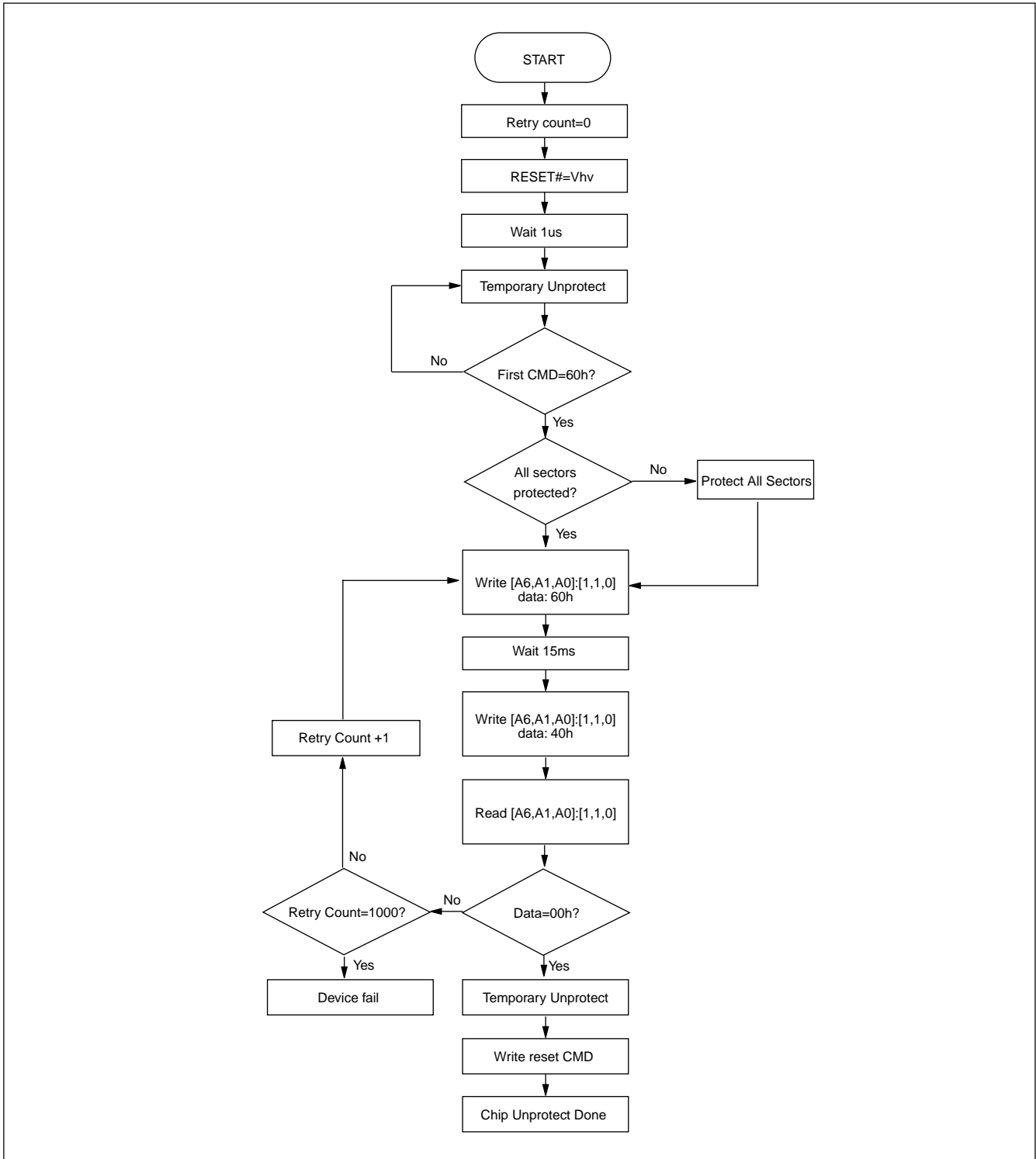


Table 5. TEMPORARY SECTOR UNPROTECT

| Parameter | Alt | Description | Condition | Speed | Unit |
|-----------|-------|---|-----------|-------|------|
| Trpvhh | Tvidr | RESET# Rise Time to Vhv and Vhv Fall Time to RESET# | MIN | 500 | nS |
| Tvhhl | Trsp | RESET# Vhv to WE# Low | MIN | 4 | uS |

Figure 14. TEMPORARY SECTOR UNPROTECT WAVEFORMS

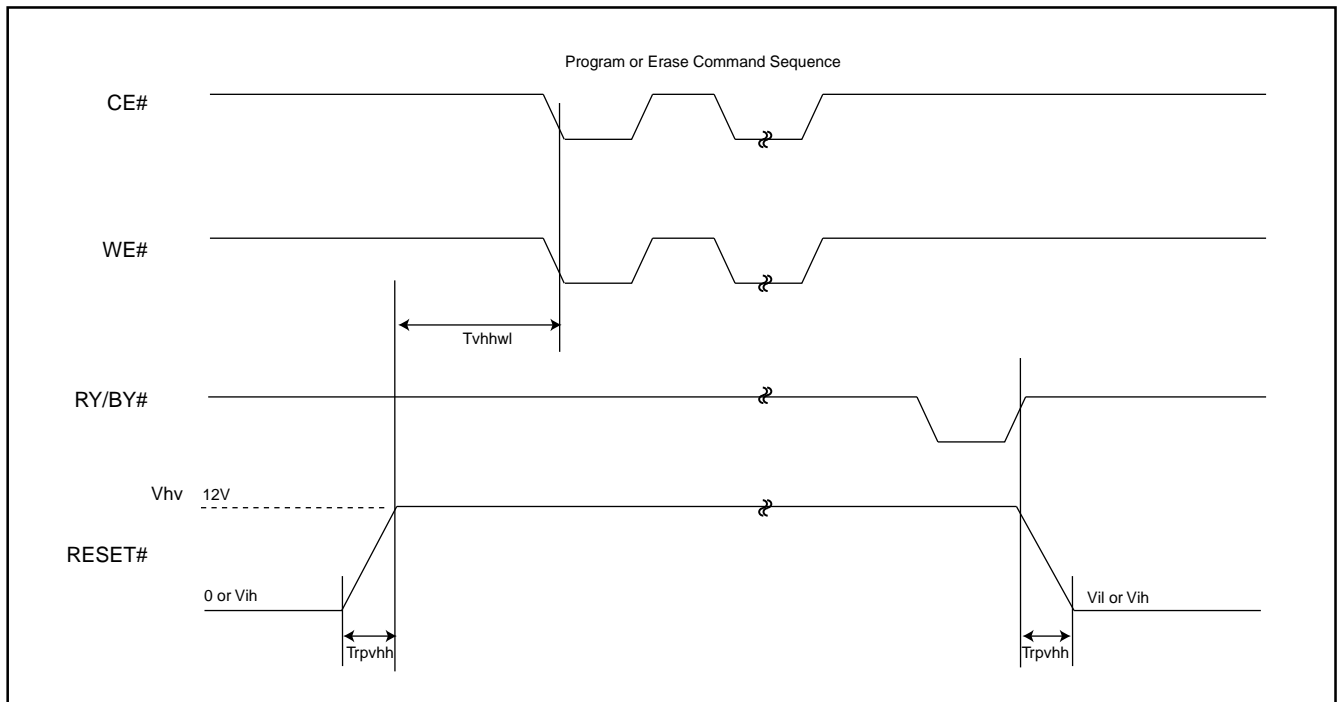
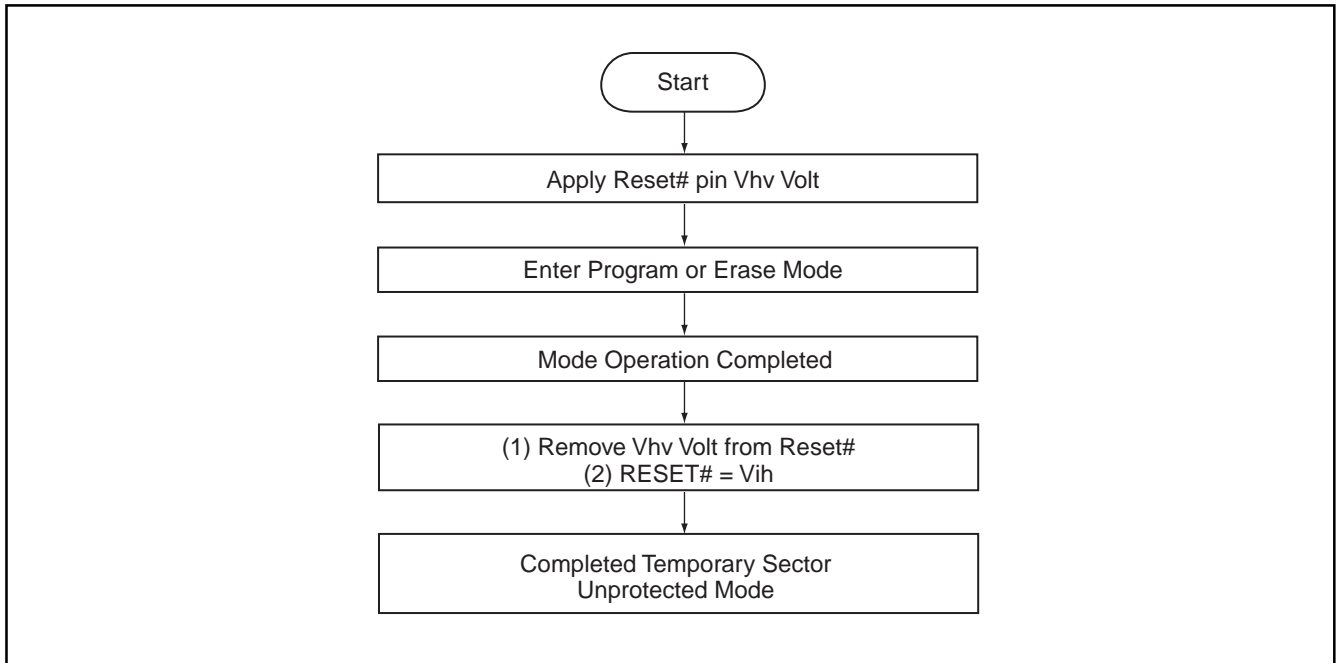
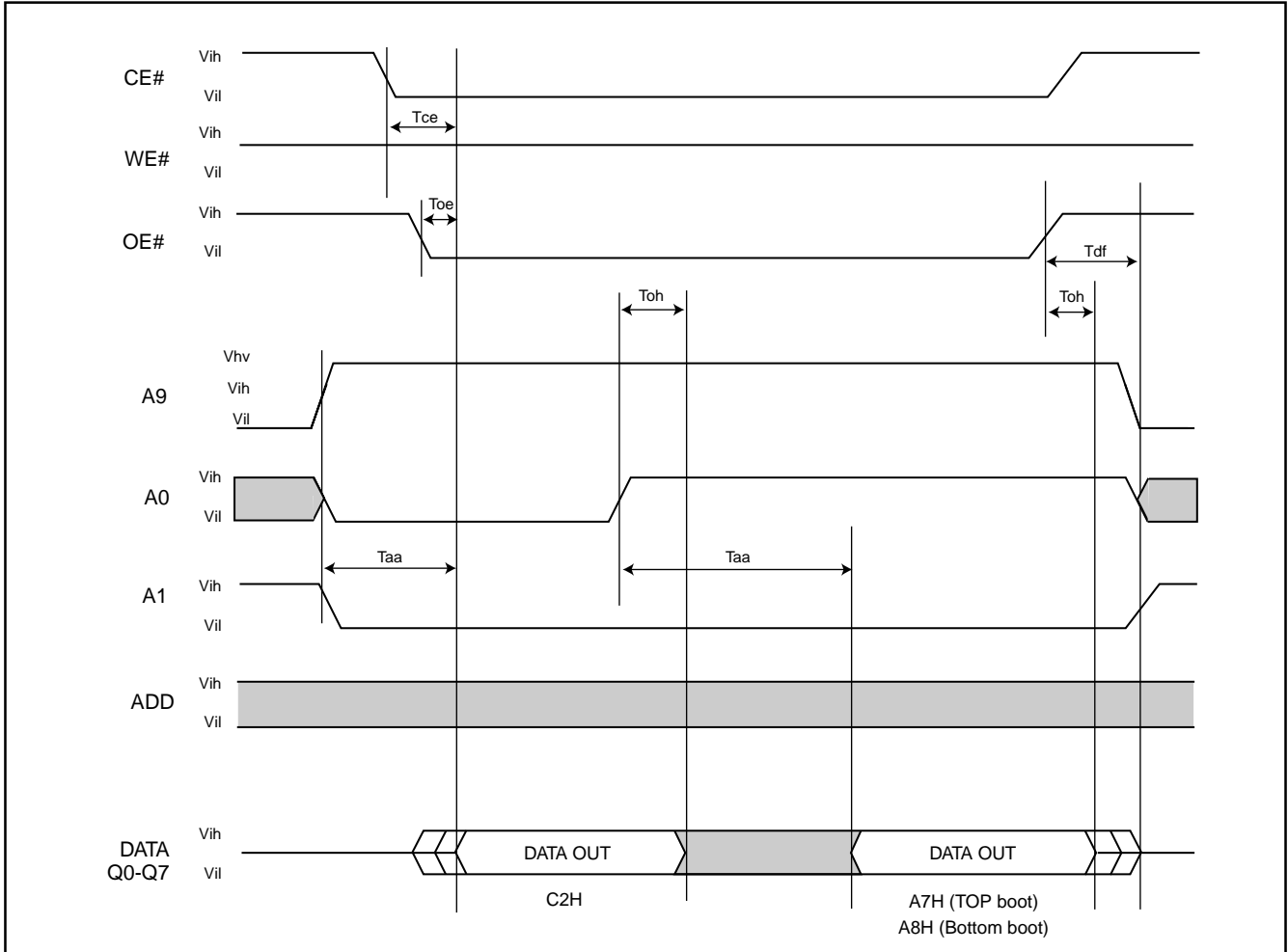


Figure 15. TEMPORARY SECTOR UNPROTECT FLOWCHART**Notes:**

1. Temporary unprotect all protected sectors Vhv=11.5~12.5V.
2. After leaving temporary unprotect mode, the previously protected sectors are again protected.

Figure 16. SILICON ID READ TIMING WAVEFORM



WRITE OPERATION STATUS

Figure 17. DATA# POLLING TIMING WAVEFORMS (DURING AUTOMATIC ALGORITHMS)

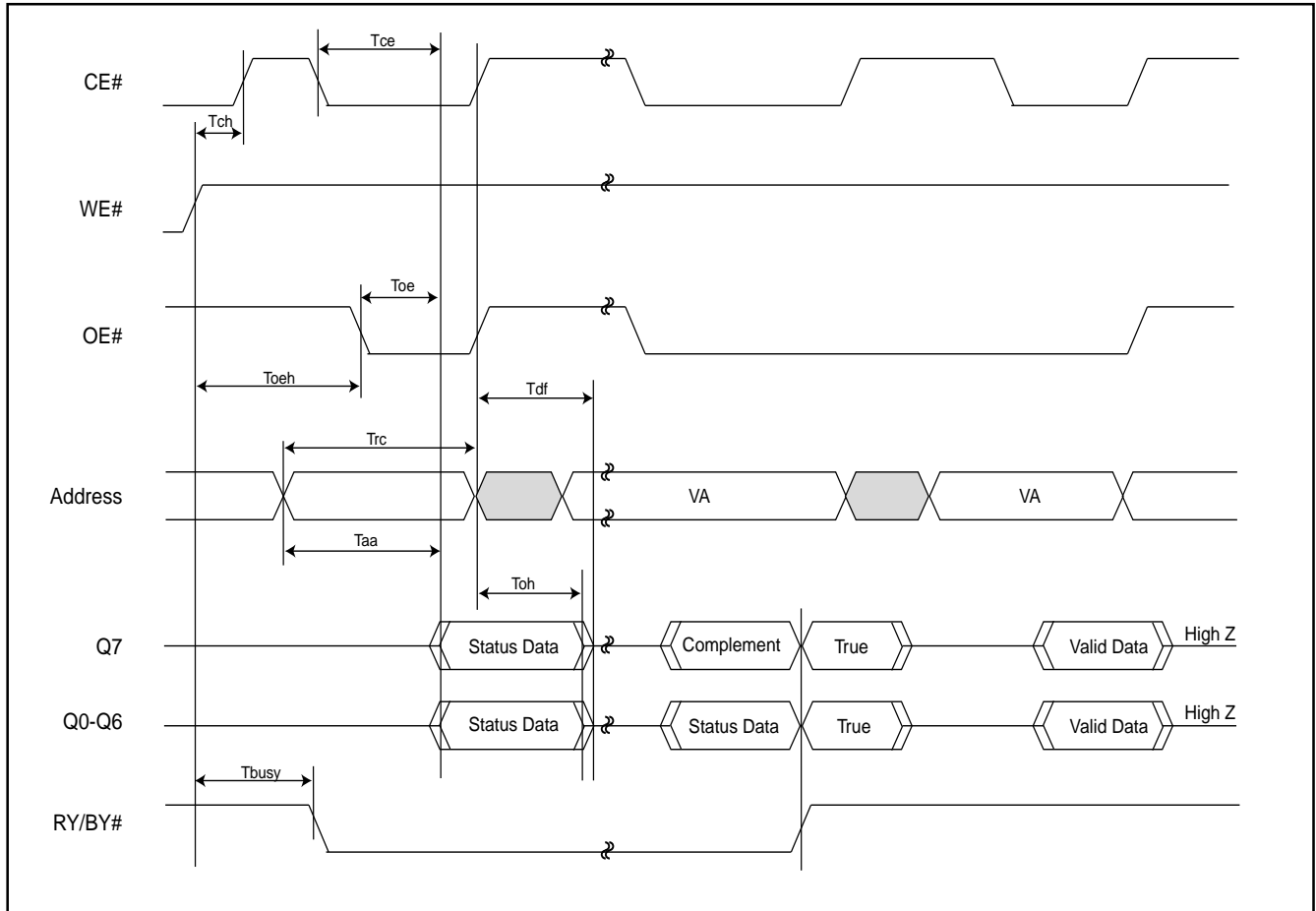
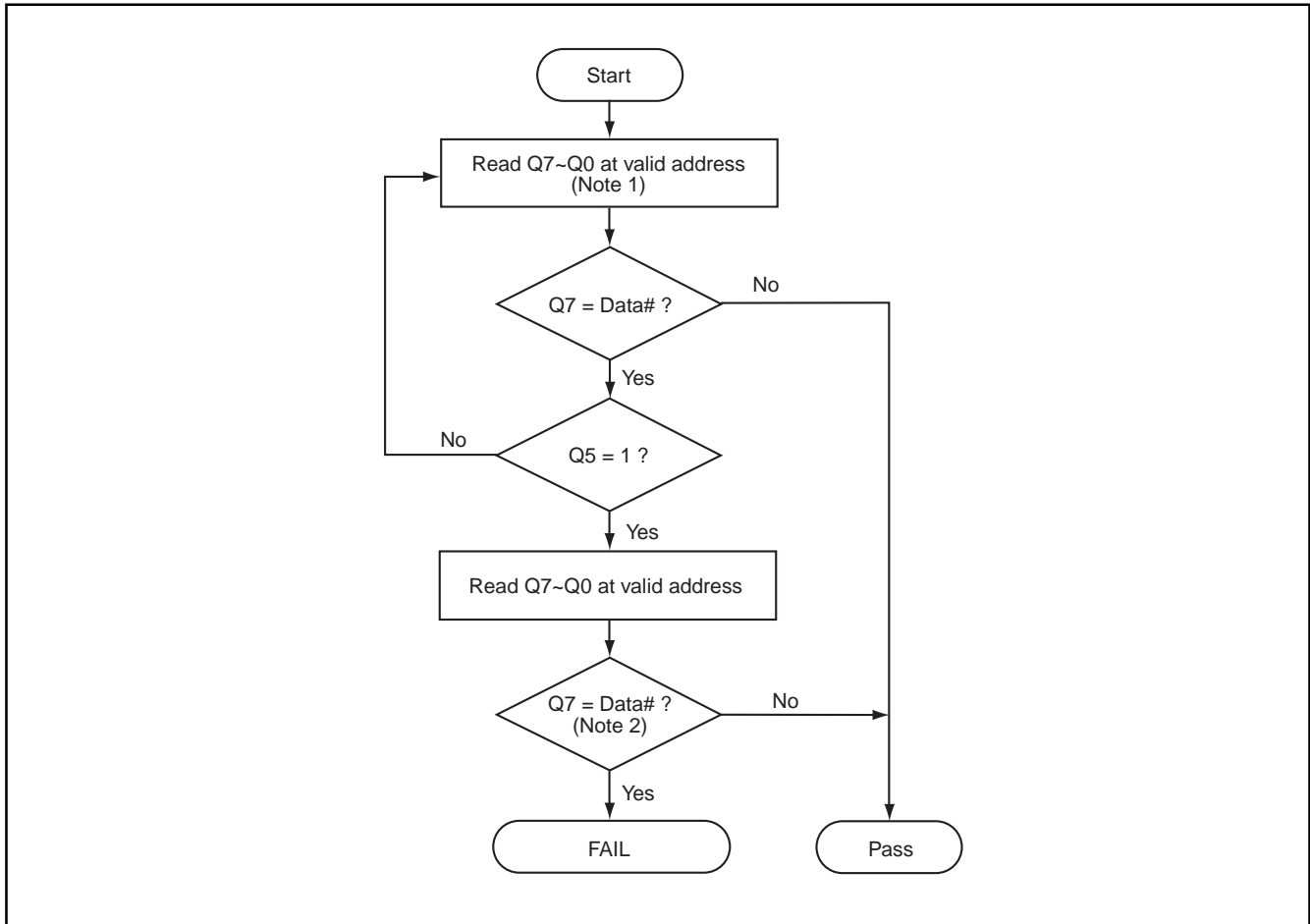


Figure 18. Data# Polling Algorithm**Notes:**

1. For programming, valid address means program address.
For erasing, valid address means erase sectors address.
2. Q7 should be rechecked even Q5="1" because Q7 may change simultaneously with Q5.

Figure 19. TOGGLE BIT TIMING WAVEFORMS (DURING AUTOMATIC ALGORITHMS)

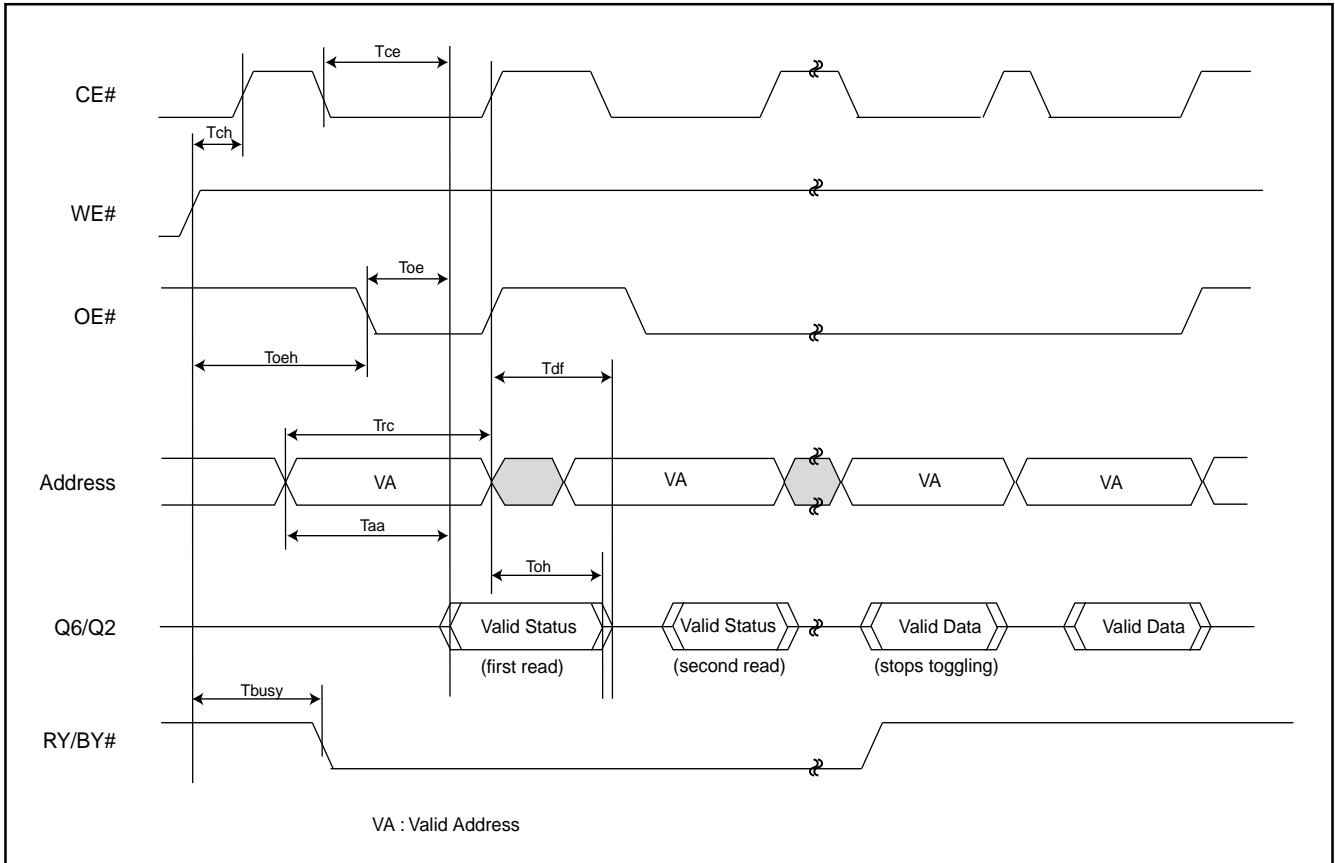
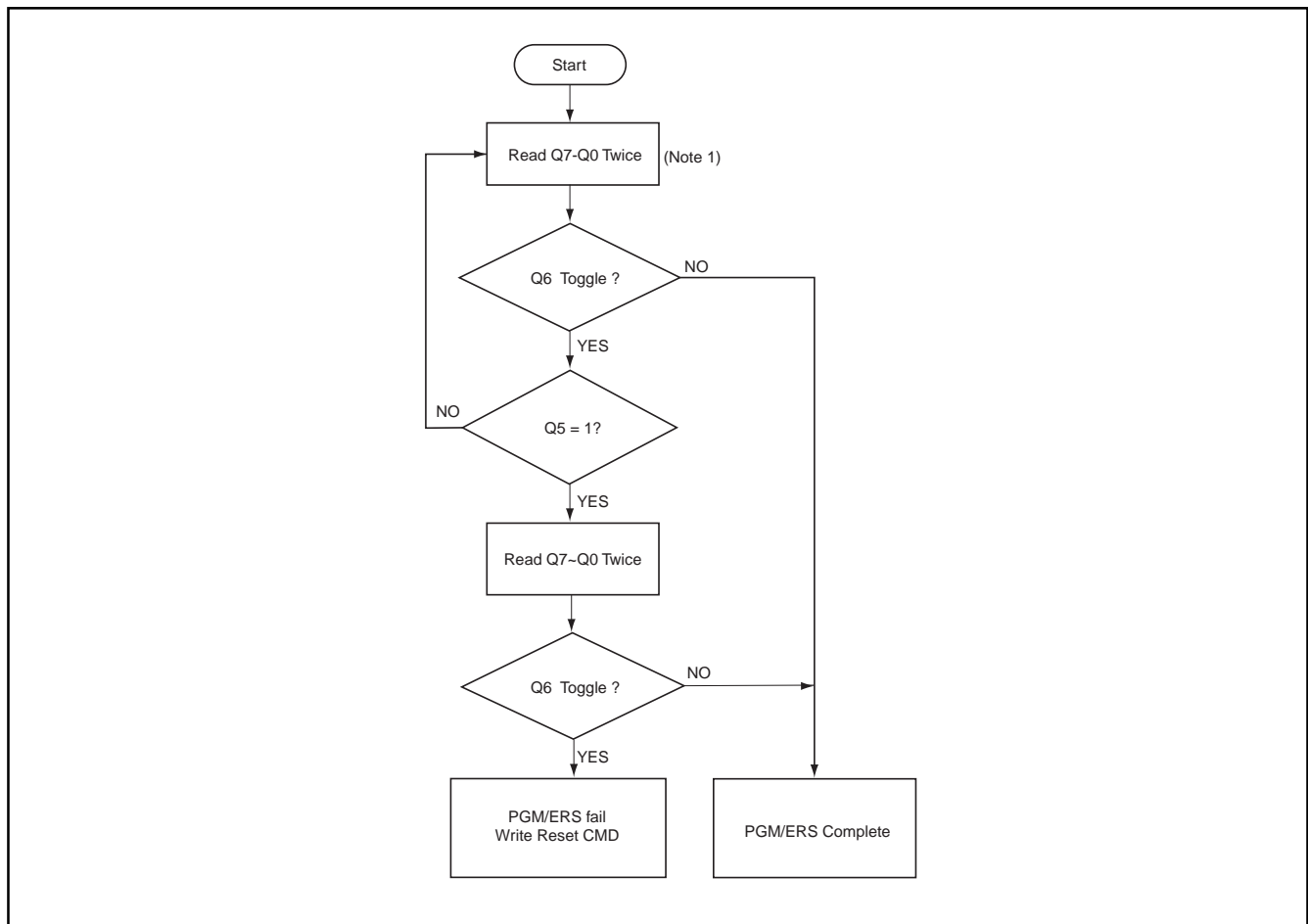


Figure 20. Toggle Bit Algorithm**Notes:**

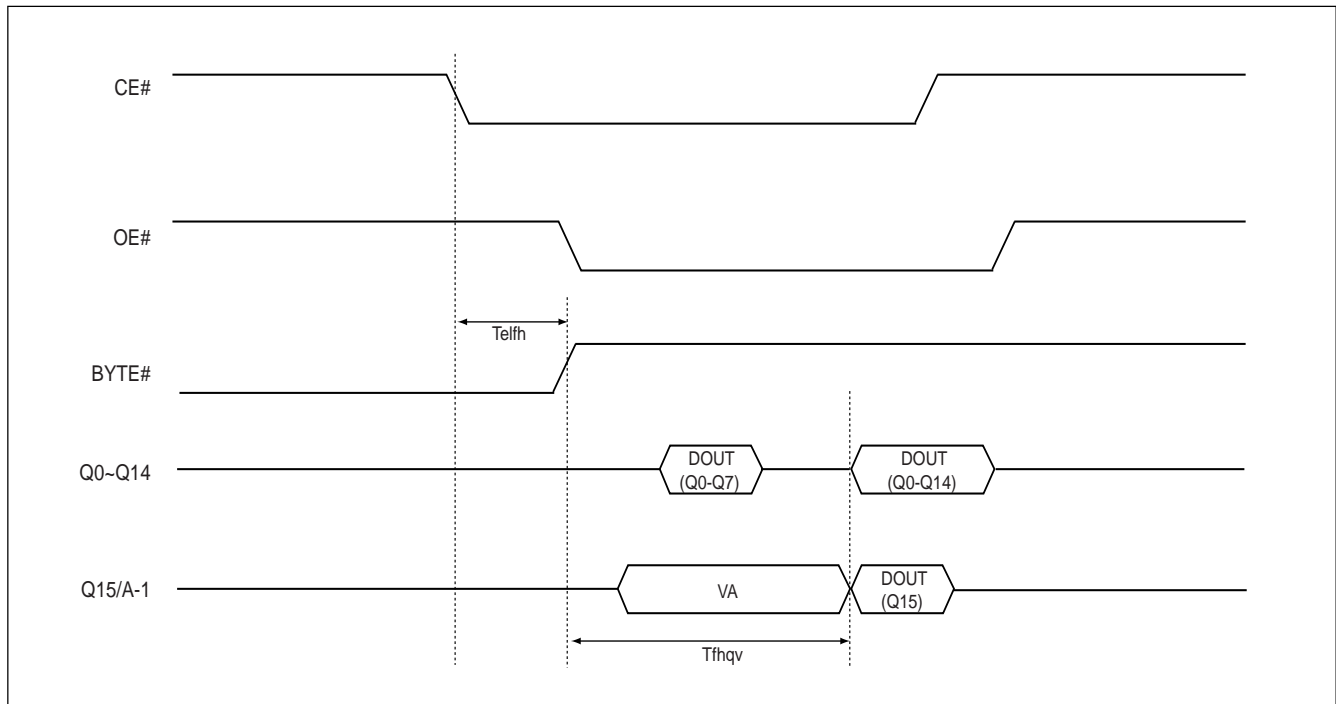
1. Read toggle bit twice to determine whether or not it is toggling.
2. Recheck toggle bit because it may stop toggling as Q5 changes to "1".

AC CHARACTERISTICS

WORD/BYTE CONFIGURATION (BYTE#)

| Parameter | Description | | Speed Options | | Unit |
|------------|-------------------------------|-----|---------------|-----|------|
| | | | -70 | -90 | |
| Telf/Telfh | CE# to BYTE# from L/H | MAX | 5 | 5 | nS |
| Tflqz | BYTE# from L to Output Hiz | MAX | 25 | 30 | nS |
| Tfhqv | BYTE# from H to Output Active | MIN | 70 | 90 | nS |

Figure 21. BYTE# TIMING WAVEFORM FOR READ OPERATIONS (BYTE# switching from byte mode to word mode)



RECOMMENDED OPERATING CONDITIONS

At Device Power-Up

AC timing illustrated in Figure A is recommended for the supply voltages and the control signals at device power-up. If the timing in the figure is ignored, the device may not operate correctly.

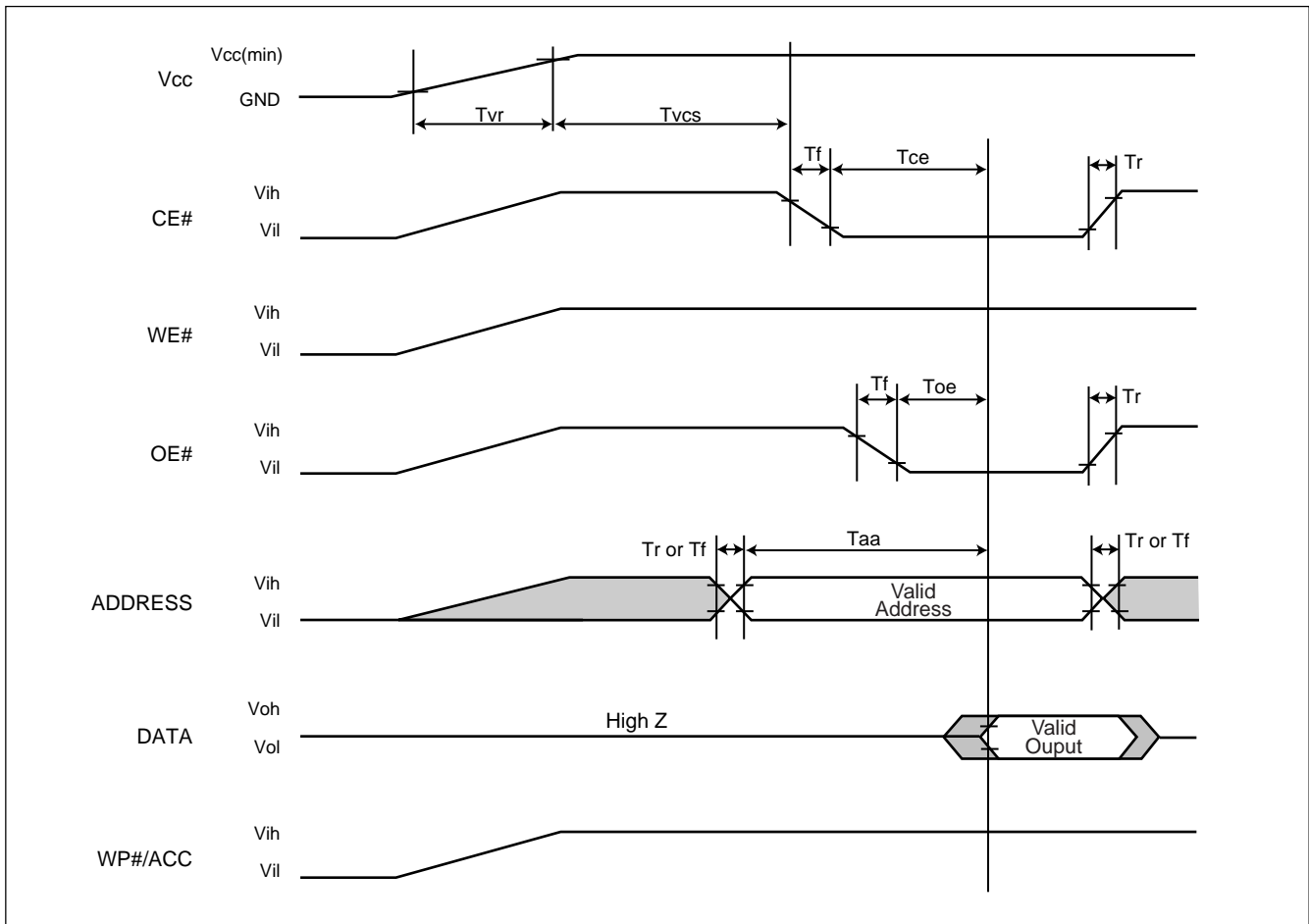


Figure A. AC Timing at Device Power-Up

| Symbol | Parameter | Min. | Max. | Unit |
|----------|------------------------|------|--------|-----------------|
| T_{vr} | Vcc Rise Time | 20 | 500000 | $\mu\text{S/V}$ |
| T_r | Input Signal Rise Time | | 20 | $\mu\text{S/V}$ |
| T_f | Input Signal Fall Time | | 20 | $\mu\text{S/V}$ |

ERASE AND PROGRAMMING PERFORMANCE

| PARAMETER | | LIMITS | | | UNITS |
|------------------------------------|------------|-----------|------|------|--------|
| | | MIN. | TYP. | MAX. | |
| Chip Erase Time | MX29LV400C | | 4 | 32 | sec |
| | MX29LV800C | | 8 | 32 | sec |
| | MX29LV160C | | 15 | 32 | sec |
| Sector Erase Time | | | 0.7 | 15 | sec |
| Erase/Program Cycles | | 100,000 | | | Cycles |
| Chip Programming Time | MX29LV400C | Byte Mode | 4.5 | 13.5 | sec |
| | | Word Mode | 3 | 9 | sec |
| | MX29LV800C | Byte Mode | 9 | 27 | sec |
| | | Word Mode | 5.8 | 17 | sec |
| | MX29LV160C | Byte Mode | 18 | 54 | sec |
| | | Word Mode | 12 | 36 | sec |
| Accelerated Byte/Word Program Time | | | 7 | 210 | uS |
| Word Program Time | | | 11 | 360 | uS |
| Byte Programming Time | | | 9 | 300 | uS |

LATCH-UP CHARACTERISTICS

| | MIN. | MAX. |
|---|--------|------------------------|
| Input Voltage voltage difference with GND on all pins except I/O pins | -1.0V | 12.5V |
| Input Voltage voltage difference with GND on all I/O pins | -1.0V | V _{cc} + 1.0V |
| V _{cc} Current | -100mA | +100mA |
| All pins included except V _{cc} . Test conditions: V _{cc} = 3.0V, one pin per testing | | |

TSOP PIN CAPACITANCE

| Parameter Symbol | Parameter Description | Test Set | TYP | MAX | UNIT |
|------------------|-------------------------|----------|-----|-----|------|
| CIN2 | Control Pin Capacitance | VIN=0 | 7.5 | 9 | pF |
| COUT | Output Capacitance | VOUT=0 | 8.5 | 12 | pF |
| CIN | Input Capacitance | VIN=0 | 6 | 7.5 | pF |

ORDERING INFORMATION

MX29LV400C T/B

| PART NO. | ACCESS TIME (ns) | OPERATING Current MAX. (mA) | STANDBY Current MAX. (uA) | PACKAGE | Remark |
|--------------------|------------------|-----------------------------|---------------------------|------------------------------------|---------|
| MX29LV400CTMC-55Q | 55 | 30 | 5 | 44 Pin SOP | PB free |
| MX29LV400CBMC-55Q | 55 | 30 | 5 | 44 Pin SOP | PB free |
| MX29LV400CTMC-70G | 70 | 30 | 5 | 44 Pin SOP | PB free |
| MX29LV400CBMC-70G | 70 | 30 | 5 | 44 Pin SOP | PB free |
| MX29LV400CTMC-90G | 90 | 30 | 5 | 44 Pin SOP | PB free |
| MX29LV400CBMC-90G | 90 | 30 | 5 | 44 Pin SOP | PB free |
| MX29LV400CTTC-55Q | 55 | 30 | 5 | 48 Pin TSOP (Normal Type) | PB free |
| MX29LV400CBTC-55Q | 55 | 30 | 5 | 48 Pin TSOP (Normal Type) | PB free |
| MX29LV400CTTC-70G | 70 | 30 | 5 | 48 Pin TSOP (Normal Type) | PB free |
| MX29LV400CBTC-70G | 70 | 30 | 5 | 48 Pin TSOP (Normal Type) | PB free |
| MX29LV400CTTC-90G | 90 | 30 | 5 | 48 Pin TSOP (Normal Type) | PB free |
| MX29LV400CBTC-90G | 90 | 30 | 5 | 48 Pin TSOP (Normal Type) | PB free |
| MX29LV400CTXBC-55Q | 55 | 30 | 5 | 48 Ball TFBGA (ball size=0.3mm) | PB free |
| MX29LV400CBXBC-55Q | 55 | 30 | 5 | 48 Ball TFBGA (ball size=0.3mm) | PB free |
| MX29LV400CTXBC-70G | 70 | 30 | 5 | 48 Ball TFBGA (ball size=0.3mm) | PB free |
| MX29LV400CBXBC-70G | 70 | 30 | 5 | 48 Ball TFBGA (ball size=0.3mm) | PB free |
| MX29LV400CTXBC-90G | 90 | 30 | 5 | 48 Ball TFBGA (ball size=0.3mm) | PB free |
| MX29LV400CBXBC-90G | 90 | 30 | 5 | 48 Ball TFBGA (ball size=0.3mm) | PB free |
| MX29LV400CTXEC-55Q | 55 | 30 | 5 | 48 Ball LFBGA (ball size=0.4mm) | PB free |
| MX29LV400CBXEC-55Q | 55 | 30 | 5 | 48 Ball LFBGA (ball size=0.4mm) | PB free |
| MX29LV400CTXEC-70G | 70 | 30 | 5 | 48 Ball LFBGA (ball size=0.4mm) | PB free |
| MX29LV400CBXEC-70G | 70 | 30 | 5 | 48 Ball LFBGA (ball size=0.4mm) | PB free |
| MX29LV400CTXEC-90G | 90 | 30 | 5 | 48 Ball LFBGA (ball size=0.4mm) | PB free |

| PART NO. | ACCESS TIME (ns) | OPERATING Current MAX. (mA) | STANDBY Current MAX. (uA) | PACKAGE | Remark |
|--------------------|------------------|-----------------------------|---------------------------|------------------------------------|---------|
| MX29LV400CBXEC-90G | 90 | 30 | 5 | 48 Ball LFBGA (ball size=0.4mm) | PB free |
| MX29LV400CTMI-55Q | 55 | 30 | 5 | 44 Pin SOP | PB free |
| MX29LV400CBMI-55Q | 55 | 30 | 5 | 44 Pin SOP | PB free |
| MX29LV400CTMI-70G | 70 | 30 | 5 | 44 Pin SOP | PB free |
| MX29LV400CBMI-70G | 70 | 30 | 5 | 44 Pin SOP | PB free |
| MX29LV400CTMI-90G | 90 | 30 | 5 | 44 Pin SOP | PB free |
| MX29LV400CBMI-90G | 90 | 30 | 5 | 44 Pin SOP | PB free |
| MX29LV400CTTI-55Q | 55 | 30 | 5 | 48 Pin TSOP (Normal Type) | PB free |
| MX29LV400CBTI-55Q | 55 | 30 | 5 | 48 Pin TSOP (Normal Type) | PB free |
| MX29LV400CTTI-70G | 70 | 30 | 5 | 48 Pin TSOP (Normal Type) | PB free |
| MX29LV400CBTI-70G | 70 | 30 | 5 | 48 Pin TSOP (Normal Type) | PB free |
| MX29LV400CTTI-90G | 90 | 30 | 5 | 48 Pin TSOP (Normal Type) | PB free |
| MX29LV400CBTI-90G | 90 | 30 | 5 | 48 Pin TSOP (Normal Type) | PB free |
| MX29LV400CTXBI-55Q | 55 | 30 | 5 | 48 Ball TFBGA (ball size=0.3mm) | PB free |
| MX29LV400CBXBI-55Q | 55 | 30 | 5 | 48 Ball TFBGA (ball size=0.3mm) | PB free |
| MX29LV400CTXBI-70G | 70 | 30 | 5 | 48 Ball TFBGA (ball size=0.3mm) | PB free |
| MX29LV400CBXBI-70G | 70 | 30 | 5 | 48 Ball TFBGA (ball size=0.3mm) | PB free |
| MX29LV400CTXBI-90G | 90 | 30 | 5 | 48 Ball TFBGA (ball size=0.3mm) | PB free |
| MX29LV400CBXBI-90G | 90 | 30 | 5 | 48 Ball TFBGA (ball size=0.3mm) | PB free |
| MX29LV400CTXEI-55Q | 55 | 30 | 5 | 48 Ball LFBGA (ball size=0.4mm) | PB free |
| MX29LV400CBXEI-55Q | 55 | 30 | 5 | 48 Ball LFBGA (ball size=0.4mm) | PB free |
| MX29LV400CTXEI-70G | 70 | 30 | 5 | 48 Ball LFBGA (ball size=0.4mm) | PB free |
| MX29LV400CBXEI-70G | 70 | 30 | 5 | 48 Ball LFBGA (ball size=0.4mm) | PB free |
| MX29LV400CTXEI-90G | 90 | 30 | 5 | 48 Ball LFBGA (ball size=0.4mm) | PB free |



MACRONIX
INTERNATIONAL Co., LTD.

MX29LV400C T/B
MX29LV800C T/B
MX29LV160C T/B

| PART NO. | ACCESS TIME (ns) | OPERATING Current MAX. (mA) | STANDBY Current MAX. (uA) | PACKAGE | Remark |
|--------------------|-----------------------------|--|--------------------------------------|------------------------------------|---------------|
| MX29LV400CBXEI-90G | 90 | 30 | 5 | 48 Ball LFBGA (ball size=0.4mm) | PB free |
| MX29LV400CTXHI-55Q | 55 | 30 | 5 | 48 Ball WFBGA (4 x 6 mm) | PB free |
| MX29LV400CBXHI-55Q | 55 | 30 | 5 | 48 Ball WFBGA (4 x 6 mm) | PB free |
| MX29LV400CTXHI-70G | 70 | 30 | 5 | 48 Ball WFBGA (4 x 6 mm) | PB free |
| MX29LV400CBXHI-70G | 70 | 30 | 5 | 48 Ball WFBGA (4 x 6 mm) | PB free |
| MX29LV400CTGBI-70G | 70 | 30 | 5 | 48 Ball XFLGA (4 x 6 x 0.5mm) | PB free |
| MX29LV400CBGBI-70G | 70 | 30 | 5 | 48 Ball XFLGA (4 x 6 x 0.5mm) | PB free |

MX29LV800C T/B

| PART NO. | ACCESS TIME (ns) | OPERATING Current MAX. (mA) | STANDBY Current MAX. (uA) | PACKAGE | Remark |
|--------------------|---------------------|--------------------------------|------------------------------|------------------------------------|---------|
| MX29LV800CTMC-55Q | 55 | 30 | 5 | 44 Pin SOP | PB free |
| MX29LV800CBMC-55Q | 55 | 30 | 5 | 44 Pin SOP | PB free |
| MX29LV800CTMC-70G | 70 | 30 | 5 | 44 Pin SOP | PB free |
| MX29LV800CBMC-70G | 70 | 30 | 5 | 44 Pin SOP | PB free |
| MX29LV800CTMC-90G | 90 | 30 | 5 | 44 Pin SOP | PB free |
| MX29LV800CBMC-90G | 90 | 30 | 5 | 44 Pin SOP | PB free |
| MX29LV800CTTC-55Q | 55 | 30 | 5 | 48 Pin TSOP (Normal Type) | PB free |
| MX29LV800CBTC-55Q | 55 | 30 | 5 | 48 Pin TSOP (Normal Type) | PB free |
| MX29LV800CTTC-70G | 70 | 30 | 5 | 48 Pin TSOP (Normal Type) | PB free |
| MX29LV800CBTC-70G | 70 | 30 | 5 | 48 Pin TSOP (Normal Type) | PB free |
| MX29LV800CTTC-90G | 90 | 30 | 5 | 48 Pin TSOP (Normal Type) | PB free |
| MX29LV800CBTC-90G | 90 | 30 | 5 | 48 Pin TSOP (Normal Type) | PB free |
| MX29LV800CTXBC-55Q | 55 | 30 | 5 | 48 Ball TFBGA (Ball Size:0.3mm) | PB free |
| MX29LV800CBXBC-55Q | 55 | 30 | 5 | 48 Ball TFBGA (Ball Size:0.3mm) | PB free |
| MX29LV800CTXBC-70G | 70 | 30 | 5 | 48 Ball TFBGA (Ball Size:0.3mm) | PB free |
| MX29LV800CBXBC-70G | 70 | 30 | 5 | 48 Ball TFBGA (Ball Size:0.3mm) | PB free |
| MX29LV800CTXBC-90G | 90 | 30 | 5 | 48 Ball TFBGA (Ball Size:0.3mm) | PB free |
| MX29LV800CBXBC-90G | 90 | 30 | 5 | 48 Ball TFBGA (Ball Size:0.3mm) | PB free |
| MX29LV800CTMI-55Q | 55 | 30 | 5 | 44 Pin SOP | PB free |
| MX29LV800CBMI-55Q | 55 | 30 | 5 | 44 Pin SOP | PB free |
| MX29LV800CTMI-70G | 70 | 30 | 5 | 44 Pin SOP | PB free |
| MX29LV800CBMI-70G | 70 | 30 | 5 | 44 Pin SOP | PB free |
| MX29LV800CTMI-90G | 90 | 30 | 5 | 44 Pin SOP | PB free |
| MX29LV800CBMI-90G | 90 | 30 | 5 | 44 Pin SOP | PB free |
| MX29LV800CTTI-55Q | 55 | 30 | 5 | 48 Pin TSOP (Normal Type) | PB free |
| MX29LV800CBTI-55Q | 55 | 30 | 5 | 48 Pin TSOP (Normal Type) | PB free |

| PART NO. | ACCESS TIME (ns) | OPERATING Current MAX. (mA) | STANDBY Current MAX. (uA) | PACKAGE | Remark |
|--------------------|---------------------|--------------------------------|------------------------------|------------------------------------|---------|
| MX29LV800CTTI-70G | 70 | 30 | 5 | 48 Pin TSOP (Normal Type) | PB free |
| MX29LV800CBTI-70G | 70 | 30 | 5 | 48 Pin TSOP (Normal Type) | PB free |
| MX29LV800CTTI-90G | 90 | 30 | 5 | 48 Pin TSOP (Normal Type) | PB free |
| MX29LV800CBTI-90G | 90 | 30 | 5 | 48 Pin TSOP (Normal Type) | PB free |
| MX29LV800CTXBI-55Q | 55 | 30 | 5 | 48 Ball TFBGA (Ball Size:0.3mm) | PB free |
| MX29LV800CBXBI-55Q | 55 | 30 | 5 | 48 Ball TFBGA (Ball Size:0.3mm) | PB free |
| MX29LV800CTXBI-70G | 70 | 30 | 5 | 48 Ball TFBGA (Ball Size:0.3mm) | PB free |
| MX29LV800CBXBI-70G | 70 | 30 | 5 | 48 Ball TFBGA (Ball Size:0.3mm) | PB free |
| MX29LV800CTXBI-90G | 90 | 30 | 5 | 48 Ball TFBGA (Ball Size:0.3mm) | PB free |
| MX29LV800CBXBI-90G | 90 | 30 | 5 | 48 Ball TFBGA (Ball Size:0.3mm) | PB free |
| MX29LV800CTXEC-55Q | 55 | 30 | 5 | 48 Ball LFBGA (Ball Size:0.4mm) | PB free |
| MX29LV800CBXEC-55Q | 55 | 30 | 5 | 48 Ball LFBGA (Ball Size:0.4mm) | PB free |
| MX29LV800CTXEC-70G | 70 | 30 | 5 | 48 Ball LFBGA (Ball Size:0.4mm) | PB free |
| MX29LV800CBXEC-70G | 70 | 30 | 5 | 48 Ball LFBGA (Ball Size:0.4mm) | PB free |
| MX29LV800CTXEC-90G | 90 | 30 | 5 | 48 Ball LFBGA (Ball Size:0.4mm) | PB free |
| MX29LV800CBXEC-90G | 90 | 30 | 5 | 48 Ball LFBGA (Ball Size:0.4mm) | PB free |
| MX29LV800CTXEI-55Q | 55 | 30 | 5 | 48 Ball LFBGA (Ball Size:0.4mm) | PB free |
| MX29LV800CBXEI-55Q | 55 | 30 | 5 | 48 Ball LFBGA (Ball Size:0.4mm) | PB free |
| MX29LV800CTXEI-70G | 70 | 30 | 5 | 48 Ball LFBGA (Ball Size:0.4mm) | PB free |
| MX29LV800CBXEI-70G | 70 | 30 | 5 | 48 Ball LFBGA (Ball Size:0.4mm) | PB free |
| MX29LV800CTXEI-90G | 90 | 30 | 5 | 48 Ball LFBGA (Ball Size:0.4mm) | PB free |
| MX29LV800CBXEI-90G | 90 | 30 | 5 | 48 Ball LFBGA (Ball Size:0.4mm) | PB free |



MACRONIX
INTERNATIONAL Co., LTD.

MX29LV400C T/B
MX29LV800C T/B
MX29LV160C T/B

| PART NO. | ACCESS | OPERATING | STANDBY | PACKAGE | Remark |
|--------------------|-----------|-------------------|-------------------|------------------------------------|---------|
| | TIME (ns) | Current MAX. (mA) | Current MAX. (uA) | | |
| MX29LV800CTTI-45Q | 45 | 30 | 5 | 48 Pin TSOP (Normal Type) | PB free |
| MX29LV800CBTI-45Q | 45 | 30 | 5 | 48 Pin TSOP (Normal Type) | PB free |
| MX29LV800CTXBI-45Q | 45 | 30 | 5 | 48 Ball TFBGA (Ball Size:0.3mm) | PB free |
| MX29LV800CBXBI-45Q | 45 | 30 | 5 | 48 Ball TFBGA (Ball Size:0.3mm) | PB free |
| MX29LV800CTXEI-45Q | 45 | 30 | 5 | 48 Ball LFBGA (Ball Size:0.4mm) | PB free |
| MX29LV800CBXEI-45Q | 45 | 30 | 5 | 48 Ball LFBGA (Ball Size:0.4mm) | PB free |
| MX29LV800CTXHI-70G | 70 | 30 | 5 | 48 Ball WFBGA (4 x 6 x 0.75mm) | PB free |
| MX29LV800CBXHI-70G | 70 | 30 | 5 | 48 Ball WFBGA (4 x 6 x 0.75mm) | PB free |
| MX29LV800CTGBI-70G | 70 | 30 | 5 | 48 Ball XFLGA (4 x 6 x 0.5mm) | PB free |
| MX29LV800CBGBI-70G | 70 | 30 | 5 | 48 Ball XFLGA (4 x 6 x 0.5mm) | PB free |

MX29LV160C T/B

| PART NO. | ACCESS TIME (ns) | OPERATING Current MAX. (mA) | STANDBY Current MAX. (uA) | PACKAGE | Remark |
|--------------------|------------------|-----------------------------|---------------------------|------------------------------------|---------|
| MX29LV160CTMC-55Q | 55 | 30 | 5 | 44 Pin SOP | PB free |
| MX29LV160CBMC-55Q | 55 | 30 | 5 | 44 Pin SOP | PB free |
| MX29LV160CTMC-70G | 70 | 30 | 5 | 44 Pin SOP | PB free |
| MX29LV160CBMC-70G | 70 | 30 | 5 | 44 Pin SOP | PB free |
| MX29LV160CTMC-90G | 90 | 30 | 5 | 44 Pin SOP | PB free |
| MX29LV160CBMC-90G | 90 | 30 | 5 | 44 Pin SOP | PB free |
| MX29LV160CTMI-55Q | 55 | 30 | 5 | 44 Pin SOP | PB free |
| MX29LV160CBMI-55Q | 55 | 30 | 5 | 44 Pin SOP | PB free |
| MX29LV160CTMI-70G | 70 | 30 | 5 | 44 Pin SOP | PB free |
| MX29LV160CBMI-70G | 70 | 30 | 5 | 44 Pin SOP | PB free |
| MX29LV160CTMI-90G | 90 | 30 | 5 | 44 Pin SOP | PB free |
| MX29LV160CBMI-90G | 90 | 30 | 5 | 44 Pin SOP | PB free |
| MX29LV160CTTC-55Q | 55 | 30 | 5 | 48 Pin TSOP (Normal Type) | PB free |
| MX29LV160CBTC-55Q | 55 | 30 | 5 | 48 Pin TSOP (Normal Type) | PB free |
| MX29LV160CTTC-70G | 70 | 30 | 5 | 48 Pin TSOP (Normal Type) | PB free |
| MX29LV160CBTC-70G | 70 | 30 | 5 | 48 Pin TSOP (Normal Type) | PB free |
| MX29LV160CTTC-90G | 90 | 30 | 5 | 48 Pin TSOP (Normal Type) | PB free |
| MX29LV160CBTC-90G | 90 | 30 | 5 | 48 Pin TSOP (Normal Type) | PB free |
| MX29LV160CTTI-55Q | 55 | 30 | 5 | 48 Pin TSOP (Normal Type) | PB free |
| MX29LV160CBTI-55Q | 55 | 30 | 5 | 48 Pin TSOP (Normal Type) | PB free |
| MX29LV160CTTI-70G | 70 | 30 | 5 | 48 Pin TSOP (Normal Type) | PB free |
| MX29LV160CBTI-70G | 70 | 30 | 5 | 48 Pin TSOP (Normal Type) | PB free |
| MX29LV160CTTI-90G | 90 | 30 | 5 | 48 Pin TSOP (Normal Type) | PB free |
| MX29LV160CBTI-90G | 90 | 30 | 5 | 48 Pin TSOP (Normal Type) | PB free |
| MX29LV160CTXBC-55Q | 55 | 30 | 5 | 48 Ball TFBGA (ball size:0.3mm) | PB free |
| MX29LV160CBXBC-55Q | 55 | 30 | 5 | 48 Ball TFBGA (ball size:0.3mm) | PB free |
| MX29LV160CTXBC-70G | 70 | 30 | 5 | 48 Ball TFBGA (ball size:0.3mm) | PB free |
| MX29LV160CBXBC-70G | 70 | 30 | 5 | 48 Ball TFBGA (ball size:0.3mm) | PB free |

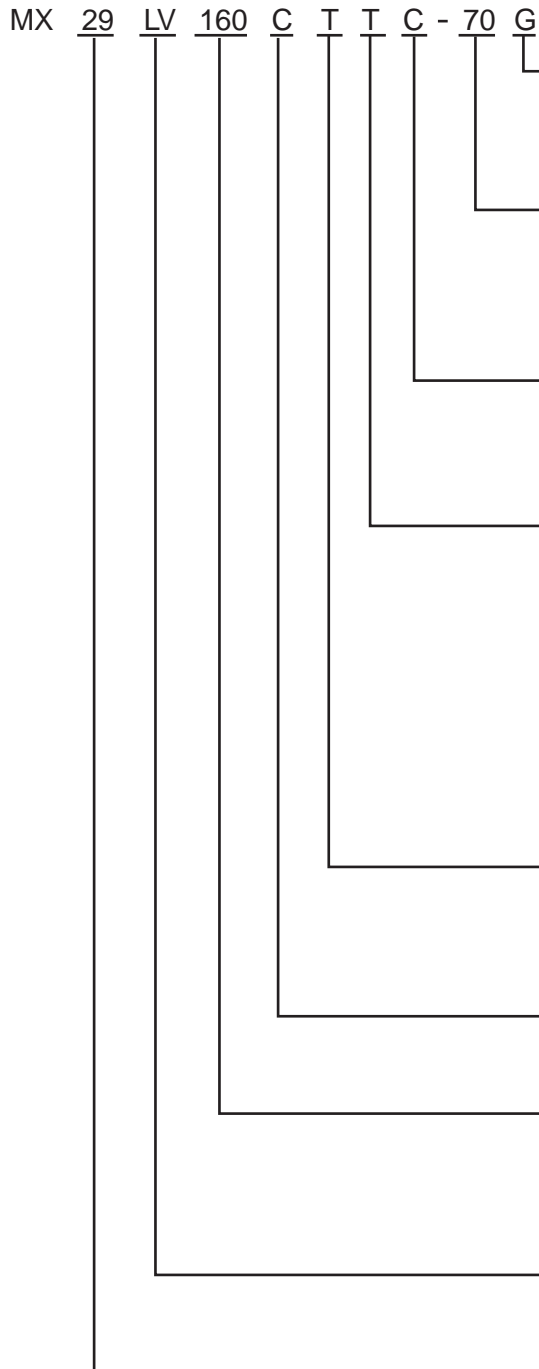


MACRONIX
INTERNATIONAL Co., LTD.

MX29LV400C T/B
MX29LV800C T/B
MX29LV160C T/B

| PART NO. | ACCESS TIME (ns) | OPERATING Current MAX. (mA) | STANDBY Current MAX. (uA) | PACKAGE | Remark |
|--------------------|------------------|-----------------------------|---------------------------|------------------------------------|---------|
| MX29LV160CTXBC-90G | 90 | 30 | 5 | 48 Ball TFBGA (ball size:0.3mm) | PB free |
| MX29LV160CBXBC-90G | 90 | 30 | 5 | 48 Ball TFBGA (ball size:0.3mm) | PB free |
| MX29LV160CTXBI-55Q | 55 | 30 | 5 | 48 Ball TFBGA (ball size:0.3mm) | PB free |
| MX29LV160CBXBI-55Q | 55 | 30 | 5 | 48 Ball TFBGA (ball size:0.3mm) | PB free |
| MX29LV160CTXBI-70G | 70 | 30 | 5 | 48 Ball TFBGA (ball size:0.3mm) | PB free |
| MX29LV160CBXBI-70G | 70 | 30 | 5 | 48 Ball TFBGA (ball size:0.3mm) | PB free |
| MX29LV160CTXBI-90G | 90 | 30 | 5 | 48 Ball TFBGA (ball size:0.3mm) | PB free |
| MX29LV160CBXBI-90G | 90 | 30 | 5 | 48 Ball TFBGA (ball size:0.3mm) | PB free |
| MX29LV160CTXEC-55Q | 55 | 30 | 5 | 48 Ball LFBGA (ball size:0.4mm) | PB free |
| MX29LV160CBXEC-55Q | 55 | 30 | 5 | 48 Ball LFBGA (ball size:0.4mm) | PB free |
| MX29LV160CTXEC-70G | 70 | 30 | 5 | 48 Ball LFBGA (ball size:0.4mm) | PB free |
| MX29LV160CBXEC-70G | 70 | 30 | 5 | 48 Ball LFBGA (ball size:0.4mm) | PB free |
| MX29LV160CTXEC-90G | 90 | 30 | 5 | 48 Ball LFBGA (ball size:0.4mm) | PB free |
| MX29LV160CBXEC-90G | 90 | 30 | 5 | 48 Ball LFBGA (ball size:0.4mm) | PB free |
| MX29LV160CTXEI-55Q | 55 | 30 | 5 | 48 Ball LFBGA (ball size:0.4mm) | PB free |
| MX29LV160CBXEI-55Q | 55 | 30 | 5 | 48 Ball LFBGA (ball size:0.4mm) | PB free |
| MX29LV160CTXEI-70G | 70 | 30 | 5 | 48 Ball LFBGA (ball size:0.4mm) | PB free |
| MX29LV160CBXEI-70G | 70 | 30 | 5 | 48 Ball LFBGA (ball size:0.4mm) | PB free |
| MX29LV160CTXEI-90G | 90 | 30 | 5 | 48 Ball LFBGA (ball size:0.4mm) | PB free |
| MX29LV160CBXEI-90G | 90 | 30 | 5 | 48 Ball LFBGA (ball size:0.4mm) | PB free |

PART NAME DESCRIPTION



OPTION:

G: Lead-free package

Q: Restricted Vcc (3.0V~3.6V) with Lead-free package

SPEED:

55: 55nS

70: 70nS

90: 90nS

TEMPERATURE RANGE:

C: Commercial (0°C to 70°C)

I: Industrial (-40°C to 85°C)

PACKAGE:

M: SOP

T: TSOP

X: LFBGA/TFBGA (CSP)

XB - 6 x 8 x 1.2mm, Pitch 0.8mm, 0.3mm Ball

XE - 6 x 8 x 1.3mm, Pitch 0.8mm, 0.4mm Ball

XH: WFBGA - 4 x 6 x 0.75mm, Pitch 0.5mm, 0.3mm Ball

GB: XFLGA - 4 x 6 x 0.5mm, Pitch 0.5mm, 0.25mm Ball

BOOT BLOCK TYPE:

T: Top Boot

B: Bottom Boot

REVISION:

C

DENSITY & MODE:

160: 16Mb, x8/x16 Boot Block

800: 8Mb, x8/x16 Boot Block

400: 4Mb, x8/x16 Boot Block

TYPE:

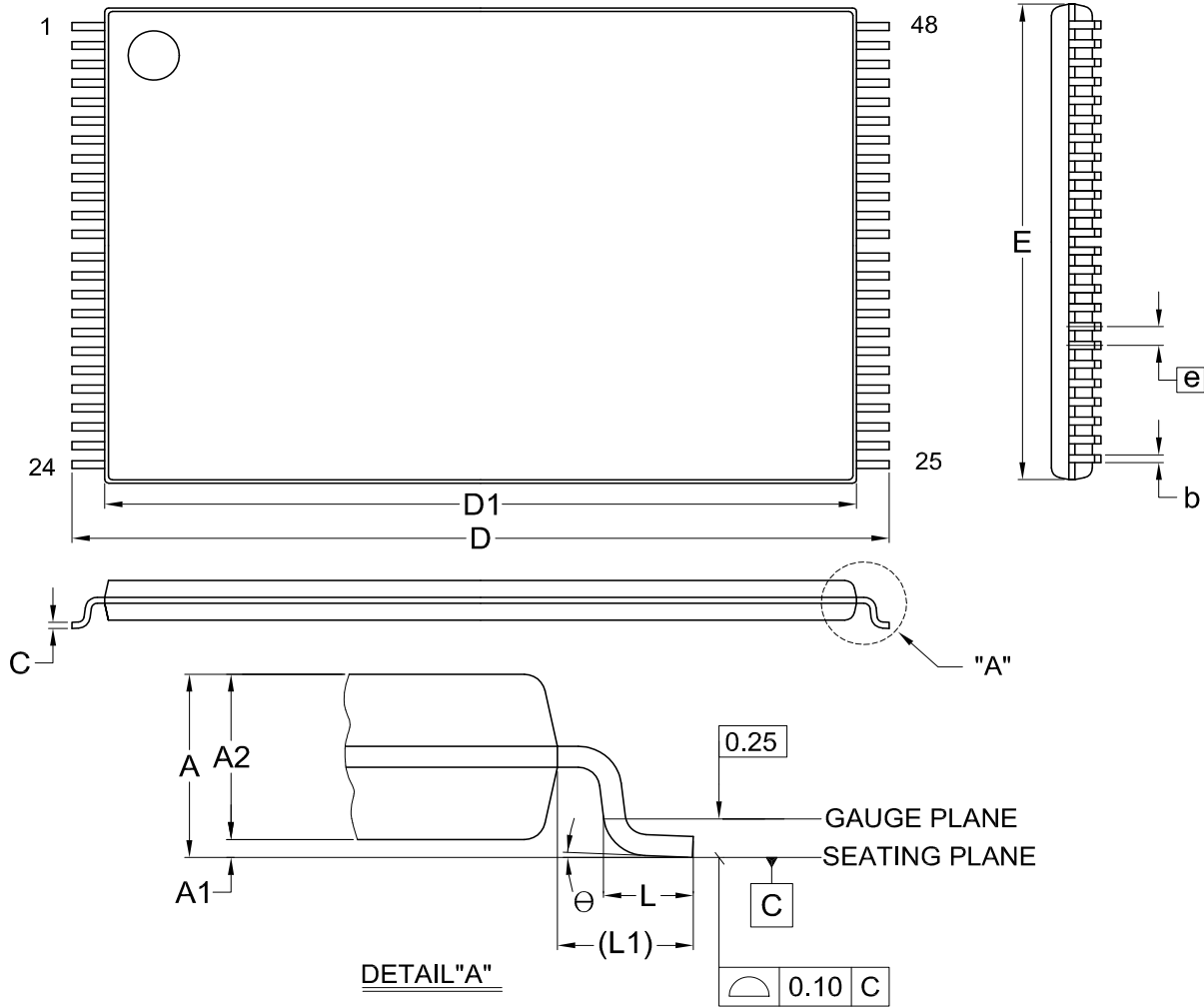
LV: 3V

DEVICE:

29:Flash

PACKAGE INFORMATION

Title: Package Outline for TSOP(I) 48L (12X20mm)NORMAL FORM

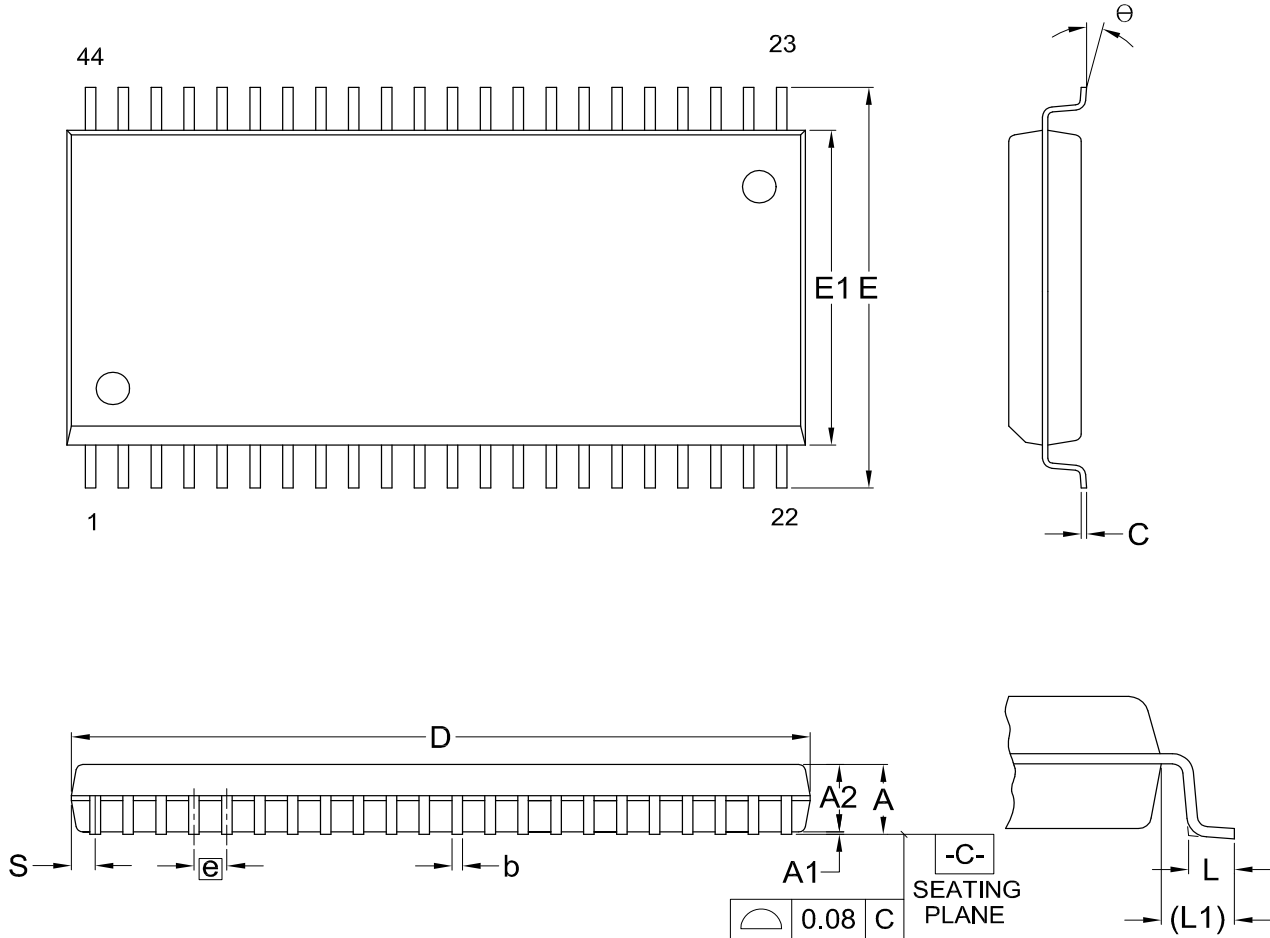


Dimensions (inch dimensions are derived from the original mm dimensions)

| SYMBOL | | A | A1 | A2 | b | C | D | D1 | E | e | L | L1 | θ |
|--------|------|-------|-------|-------|-------|-------|-------|-------|-------|-------|-------|-------|----------|
| mm | Min. | --- | 0.05 | 0.95 | 0.17 | 0.10 | 19.80 | 18.30 | 11.90 | --- | 0.50 | 0.70 | 0 |
| | Nom. | --- | 0.10 | 1.00 | 0.20 | 0.13 | 20.00 | 18.40 | 12.00 | 0.50 | 0.60 | 0.80 | 5 |
| | Max. | 1.20 | 0.15 | 1.05 | 0.27 | 0.21 | 20.20 | 18.50 | 12.10 | --- | 0.70 | 0.90 | 8 |
| Inch | Min. | --- | 0.002 | 0.037 | 0.007 | 0.004 | 0.780 | 0.720 | 0.469 | --- | 0.020 | 0.028 | 0 |
| | Nom. | --- | 0.004 | 0.039 | 0.008 | 0.005 | 0.787 | 0.724 | 0.472 | 0.020 | 0.024 | 0.031 | 5 |
| | Max. | 0.047 | 0.006 | 0.041 | 0.011 | 0.008 | 0.795 | 0.728 | 0.476 | --- | 0.028 | 0.035 | 8 |

| DWG.NO. | REVISION | REFERENCE | | | ISSUE DATE |
|-----------|----------|-----------|------|--|------------|
| | | JEDEC | EIAJ | | |
| 6110-1607 | 8 | MO-142 | | | 2007/08/03 |

Doc. Title: Package Outline for SOP 44L (500MIL)



Dimensions (inch dimensions are derived from the original mm dimensions)

| SYMBOL | | A | A1 | A2 | b | C | D | E | E1 | e | L | L1 | S | θ |
|--------|------|-------|-------|-------|-------|-------|-------|-------|-------|-------|-------|-------|-------|----|
| UNIT | | | | | | | | | | | | | | |
| mm | Min. | --- | 0.10 | 2.59 | 0.36 | 0.15 | 28.37 | 15.83 | 12.47 | --- | 0.56 | 1.51 | 0.78 | 0 |
| | Nom. | --- | 0.15 | 2.69 | 0.41 | 0.20 | 28.50 | 16.03 | 12.60 | 1.27 | 0.76 | 1.71 | 0.91 | 5 |
| | Max. | 3.00 | 0.20 | 2.80 | 0.51 | 0.25 | 28.63 | 16.23 | 12.73 | --- | 0.96 | 1.91 | 1.04 | 10 |
| Inch | Min. | --- | 0.004 | 0.102 | 0.014 | 0.006 | 1.117 | 0.623 | 0.491 | --- | 0.022 | 0.059 | 0.031 | 0 |
| | Nom. | --- | 0.006 | 0.106 | 0.016 | 0.008 | 1.122 | 0.631 | 0.496 | 0.050 | 0.030 | 0.067 | 0.036 | 5 |
| | Max. | 0.118 | 0.008 | 0.110 | 0.020 | 0.010 | 1.127 | 0.639 | 0.501 | --- | 0.038 | 0.075 | 0.041 | 10 |

| DWG.NO. | REVISION | REFERENCE | | | ISSUE DATE |
|-----------|----------|-----------|------|--|------------|
| | | JEDEC | EIAJ | | |
| 6110-1405 | 7 | MO-175 | | | 2008/02/18 |

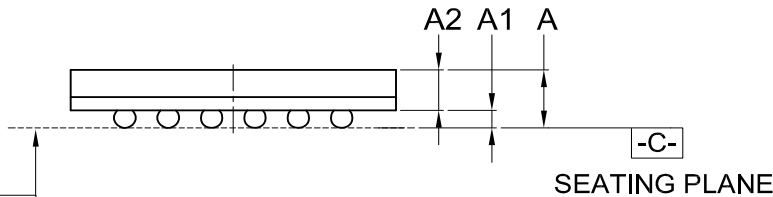
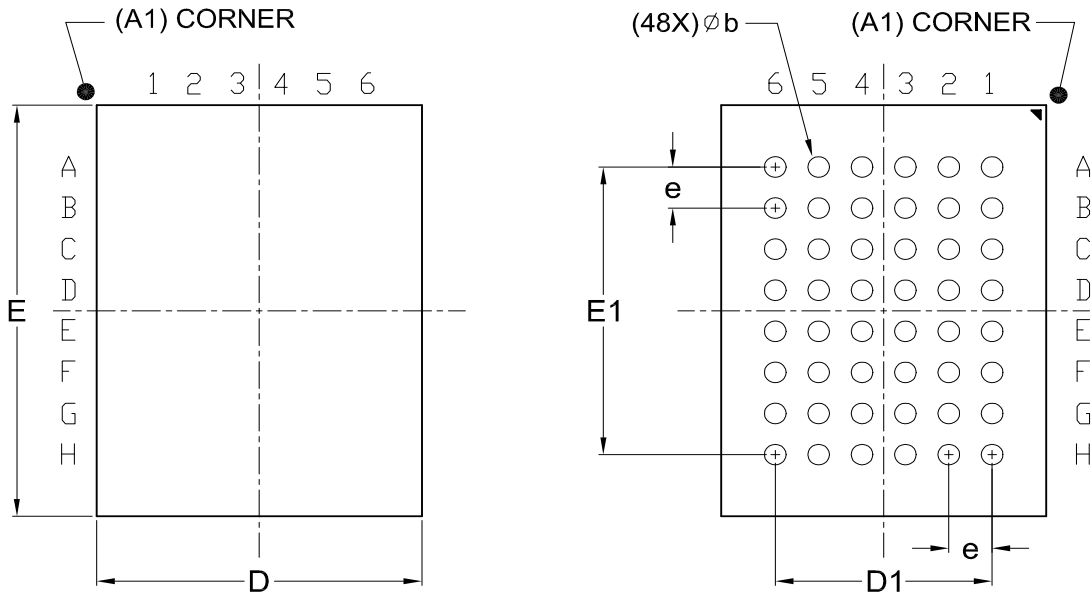
The information contained herein is the exclusive property of Macronix and shall not be distributed, reproduced, or disclosed in whole or in part without prior written permission of Macronix.

48-Ball CSP (for MX29LV400C/MX29LV800C/MX29LV160C TXBC/TXBI/BXBC/BXBI)

Title: Package Outline for CSP 48BALL(6X8X1.2MM,BALL PITCH 0.8MM,BALL DIAMETER 0.3MM)

TOP VIEW

BOTTOM VIEW



0.08 C

Dimensions (inch dimensions are derived from the original mm dimensions)

| SYMBOL | | A | A1 | A2 | b | D | D1 | E | E1 | e |
|--------|------|-------|-------|-------|-------|-------|-------|-------|-------|-------|
| mm | Min. | --- | 0.18 | 0.65 | 0.25 | 5.90 | | 7.90 | | |
| | Nom. | --- | 0.23 | --- | 0.30 | 6.00 | 4.00 | 8.00 | 5.60 | 0.80 |
| | Max. | 1.20 | 0.28 | --- | 0.35 | 6.10 | | 8.10 | | |
| Inch | Min. | --- | 0.007 | 0.026 | 0.010 | 0.232 | | 0.311 | | |
| | Nom. | --- | 0.009 | --- | 0.012 | 0.236 | 0.157 | 0.315 | 0.220 | 0.031 |
| | Max. | 0.047 | 0.011 | --- | 0.014 | 0.240 | | 0.319 | | |

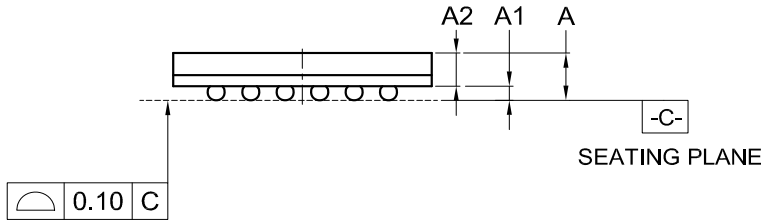
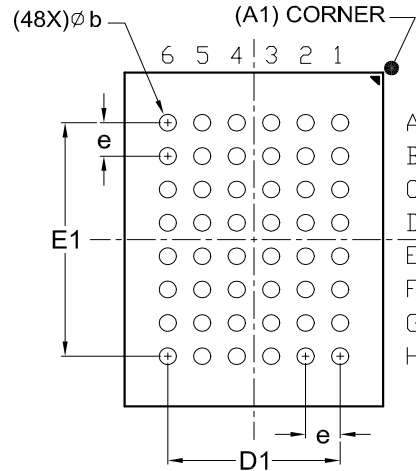
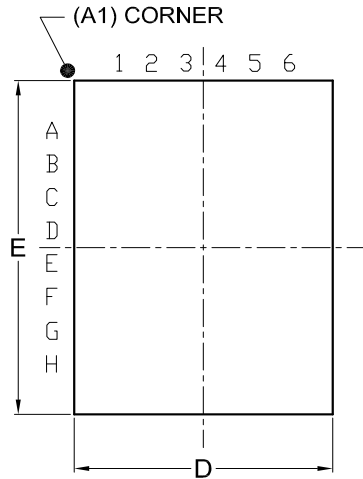
| DWG.NO. | REVISION | REFERENCE | | | ISSUE DATE |
|-----------|----------|-----------|------|--|------------|
| | | JEDEC | EIAJ | | |
| 6110-4201 | 6 | MO-210 | | | 03-29-'06 |

48-Ball CSP (for MX29LV400C/MX29LV800C/MX29LV160C TXEC/TXEI/BXEC/BXEI)

Title: Package Outline for CSP 48BALL(6X8X1.3MM,BALL PITCH 0.8MM,BALL DIAMETER 0.4MM)

TOP VIEW

BOTTOM VIEW



Dimensions (inch dimensions are derived from the original mm dimensions)

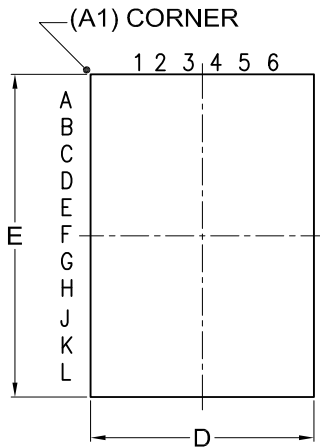
| SYMBOL | | A | A1 | A2 | b | D | D1 | E | E1 | e |
|--------|------|-------|-------|-------|-------|-------|-------|-------|-------|-------|
| mm | Min. | --- | 0.25 | 0.65 | 0.35 | 5.90 | | 7.90 | | |
| | Nom. | --- | 0.30 | --- | 0.40 | 6.00 | 4.00 | 8.00 | 5.60 | 0.80 |
| | Max. | 1.30 | 0.35 | --- | 0.45 | 6.10 | | 8.10 | | |
| Inch | Min. | --- | 0.010 | 0.026 | 0.014 | 0.232 | | 0.311 | | |
| | Nom. | --- | 0.012 | --- | 0.016 | 0.236 | 0.157 | 0.315 | 0.220 | 0.031 |
| | Max. | 0.051 | 0.014 | --- | 0.018 | 0.240 | | 0.319 | | |

| DWG.NO. | REVISION | REFERENCE | | | ISSUE DATE |
|-----------|----------|-----------|------|--|------------|
| | | JEDEC | EIAJ | | |
| 6110-4202 | 4 | MO-219 | | | 12-12-'03 |

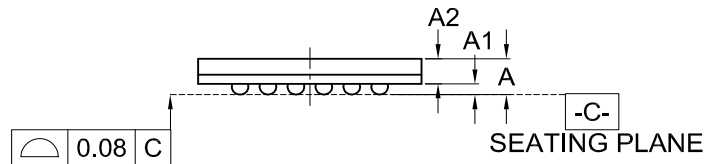
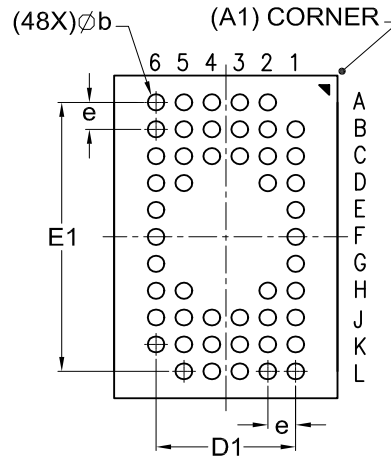
48-Ball CSP (for MX29LV400C/MX29LV800C TXHC/TXHI/BXHC/BXHI)

Title: Package Outline for CSP 48BALL(4X6X0.75MM,BALL PITCH 0.5MM,BALL DIAMETER 0.3MM)

TOP VIEW



BOTTOM VIEW



Dimensions (inch dimensions are derived from the original mm dimensions)

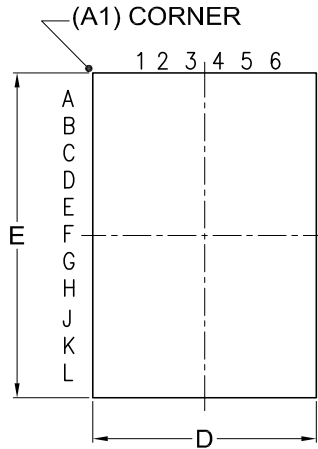
| SYMBOL | | A | A1 | A2 | b | D | D1 | E | E1 | e |
|--------|------|-------|-------|-------|-------|-------|-------|-------|-------|-------|
| mm | Min. | --- | 0.16 | 0.41 | 0.25 | 3.90 | | 5.90 | | |
| | Nom. | --- | 0.21 | --- | 0.30 | 4.00 | 2.50 | 6.00 | 5.00 | 0.50 |
| | Max. | 0.75 | 0.26 | --- | 0.35 | 4.10 | | 6.10 | | |
| Inch | Min. | --- | 0.006 | 0.016 | 0.010 | 0.154 | | 0.232 | | |
| | Nom. | --- | 0.008 | --- | 0.012 | 0.157 | 0.098 | 0.236 | 0.197 | 0.020 |
| | Max. | 0.030 | 0.010 | --- | 0.014 | 0.161 | | 0.240 | | |

| DWG.NO. | REVISION | REFERENCE | | | ISSUE DATE |
|-----------|----------|-----------|------|--|------------|
| | | JEDEC | EIAJ | | |
| 6110-4250 | 1 | | | | 02-14-'06 |

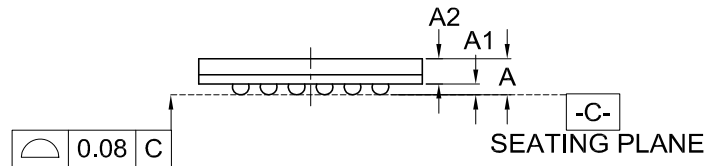
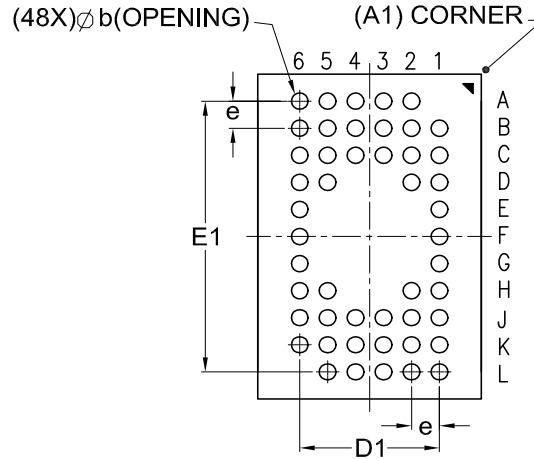
48-Ball XFLGA (for MX29LV400C/MX29LV800C TGBI/BGBI)

Title: Package Outline for XFLGA 48L (4x6x0.5MM, LAND PITCH 0.5MM, LAND OPENING 0.25MM)

TOP VIEW



BOTTOM VIEW



Dimensions (inch dimensions are derived from the original mm dimensions)

| SYMBOL | | A | A1 | A2 | b | D | D1 | E | E1 | e |
|--------|------|-------|-------|-------|-------|-------|-------|-------|-------|-------|
| mm | Min. | --- | 0.02 | 0.33 | 0.20 | 3.90 | --- | 5.90 | --- | --- |
| | Nom. | --- | 0.05 | --- | 0.25 | 4.00 | 2.50 | 6.00 | 5.00 | 0.50 |
| | Max. | 0.50 | 0.08 | --- | 0.30 | 4.10 | --- | 6.10 | --- | --- |
| Inch | Min. | --- | 0.001 | 0.013 | 0.008 | 0.154 | --- | 0.232 | --- | --- |
| | Nom. | --- | 0.002 | --- | 0.010 | 0.157 | 0.098 | 0.236 | 0.197 | 0.020 |
| | Max. | 0.020 | 0.003 | --- | 0.012 | 0.161 | --- | 0.240 | --- | --- |

| DWG.NO. | REVISION | REFERENCE | | | ISSUE DATE |
|-----------|----------|-----------|------|--|------------|
| | | JEDEC | EIAJ | | |
| 6110-3501 | 0 | MO-222 | | | 08-16-'06 |

REVISION HISTORY

| Revision No. | Description | Page | Date |
|---------------------|---|---------------------------|-------------|
| 1.1 | 1. Data modification | All | AUG/17/2006 |
| 1.2 | 1. Added 48-ball XFLGA package information | P4,7,9,62 P67,71,72,78 | SEP/19/2006 |
| 1.3 | 1. Added statement | P80 | NOV/06/2006 |
| 1.4 | 1. Removed MX29LV160CTGBI-70 & MX29LV160CBGBI-70 2. Modified ordering information | P66,72 P58~65 | MAR/21/2007 |
| 1.5 | 1. Removed 48-Ball XFLGA package 2. Added note for Absolute Maximum Stress Ratings | P9 P30 | JUL/23/2007 |
| 1.6 | 1. Revised package type from FBGA(CSP) to LFBGA/TFBGA(CSP) | P66 | NOV/26/2007 |
| 1.7 | 1. Revised "CFI Mode" statement | P27 | DEC/28/2007 |
| 1.8 | 1. Revised statement | P1,18,23 | JAN/15/2008 |
| 1.9 | 1. Added note 4 into table 3. Command Definitions | P22 | JAN/17/2008 |
| 2.0 | 1. Modified Figure 10. CE# Controlled Write Timing Waveform | P43 | FEB/15/2008 |
| 2.1 | 1. Announced "phase-out" wording | P1,2 | APR/08/2008 |
| 2.2 | 1. Renamed CSP package as TFBGA,LFBGA, WFBGA and XFLGA | P3,4,7,10, P59~66 | AUG/15/2008 |
| 2.3 | 1. Added note into DC Characteristics | P32 | DEC/17/2008 |



MACRONIX
INTERNATIONAL Co., LTD.

MX29LV400C T/B
MX29LV800C T/B
MX29LV160C T/B

Macronix's products are not designed, manufactured, or intended for use for any high risk applications in which the failure of a single component could cause death, personal injury, severe physical damage, or other substantial harm to persons or property, such as life-support systems, high temperature automotive, medical, aircraft and military application. Macronix and its suppliers will not be liable to you and/or any third party for any claims, injuries or damages that may be incurred due to use of Macronix's products in the prohibited applications.

MACRONIX INTERNATIONAL Co., LTD.

Macronix Offices : Taiwan

Headquarters, FAB2

Macronix, International Co., Ltd.

16, Li-Hsin Road, Science Park, Hsinchu,
Taiwan, R.O.C.

Tel: +886-3-5786688

Fax: +886-3-5632888

Taipei Office

Macronix, International Co., Ltd.

19F, 4, Min-Chuan E. Road, Sec. 3, Taipei,
Taiwan, R.O.C.

Tel: +886-2-2509-3300

Fax: +886-2-2509-2200

Macronix Offices : China

Macronix (Hong Kong) Co., Limited.

702-703, 7/F, Building 9, Hong Kong Science Park,
5 Science Park West Avenue, Sha Tin,
N.T.

Tel: +86-852-2607-4289

Fax: +86-852-2607-4229

Macronix (Hong Kong) Co., Limited,

SuZhou Office

No.5, XingHai Rd, SuZhou Industrial Park,
SuZhou China 215021

Tel: +86-512-62580888 Ext: 3300

Fax: +86-512-62586799

Macronix (Hong Kong) Co., Limited,

Shenzhen Office

Room 1401 & 1404, Bldcok A, TianAN Hi-Tech PLAZA Tower,
Che Gong Miao, FutianDistrict, Shenzhen PRC 518040

Tel: +86-755-83433579

Fax: +86-755-83438078

Macronix Offices : Japan

Macronix Asia Limited.

NKF Bldg. 5F, 1-2 Higashida-cho,
Kawasaki-ku Kawasaki-shi,
Kanagawa Pref. 210-0005, Japan

Tel: +81-44-246-9100

Fax: +81-44-246-9105

Macronix Offices : Korea

Macronix Asia Limited.

#906, 9F, Kangnam Bldg., 1321-4, Seocho-Dong, Seocho-Ku,
135-070, Seoul, Korea

Tel: +82-02-588-6887

Fax: +82-02-588-6828

Macronix Offices : Singapore

Macronix Pte. Ltd.

1 Marine Parade Central, #11-03 Parkway Centre,
Singapore 449408

Tel: +65-6346-5505

Fax: +65-6348-8096

Macronix Offices : Europe

Macronix Europe N.V.

Koningin Astridlaan 59, Bus 1 1780
Wommel Belgium

Tel: +32-2-456-8020

Fax: +32-2-456-8021

Macronix Offices : USA

Macronix America, Inc.

680 North McCarthy Blvd. Milpitas, CA 95035,
U.S.A.

Tel: +1-408-262-8887

Fax: +1-408-262-8810

<http://www.macronix.com>
