

**High-side Power  
Distribution Switch  
NCT3521U/ NCT3521U-2**

**-Table of Content-**

1. GENERAL DESCRIPTION .....	1
2. FEATURES .....	1
3. APPLICATIONS .....	2
4. PIN CONFIGURATION AND DESCRIPTION.....	2
5. TYPICAL APPLICATION CIRCUIT.....	3
6. BLOCK DIAGRAM.....	3
7. FUNCTIONAL DESCRIPTION .....	4
8. ELECTRICAL CHARACTERISTICS.....	5
9. PACKAGE DIMENSION.....	7
10. ORDERING INFORMATION .....	11
11. TOP MARKING SPECIFICATION .....	12
12. REVISION HISTORY.....	12

## 1. GENERAL DESCRIPTION

The NCT3521 power switch is an integrated 80mΩ power switch IC designed for high-side load switching applications.

The NCT3521 power switch operates with an input voltage range from 3.0 to 5.5V, making it ideal for both 3V and 5V systems. The NCT3521 Power Switch also features an under-voltage lock out which turns the switch off when an input under-voltage condition exists. The NCT3521 also have several protection that include current limiting, and thermal shutdown to prevent catastrophic switch failure caused by increasing power dissipation when continuous heavy loads or short circuit occurs. And a built-in charge pump is used to drive the N-channel MOSFET that is free of parasitic body diode to eliminate any reversed current flow across the switch when it is powered off. The NCT3521 features shutdown discharge function and soft-start function, this makes the NCT3521 has slowly turn on and fast turn off features.

Its low quiescent current and small package is particularly suitable in battery-powered equipment. In shutdown mode, the quiescent current decrease to less than 1uA.

## 2. FEATURES

- 80mΩ High-Side MOSFET
- Continues current up to 2A, Current trip threshold 2.5A
- Adjustable Soft-start (NCT3521U-2, SOT23-6 package)
- Operating Range from 2.7 to 5.5V
- 1.9mS Typical VOUT Turn-On Rise Time
- Under voltage Lockout
- 70uA Quiescent Supply Current
- 1uA Shutdown Current
- Active-High Enable Pin
- Fast response time at OCP
- Reverse Input-Output Voltage Protection
- Adjustable Shutdown Discharge
- Slowly turn on and fast turn off
- SOT-23-6/ SOT-23-5 Lead Free (ROHS Compliant) and Halogen Free Package

### 3. APPLICATIONS

- High-Side Power Protection Switch
- Hot Plug-Powered Hubs
- Battery-Charger Circuits

### 4. PIN CONFIGURATION AND DESCRIPTION

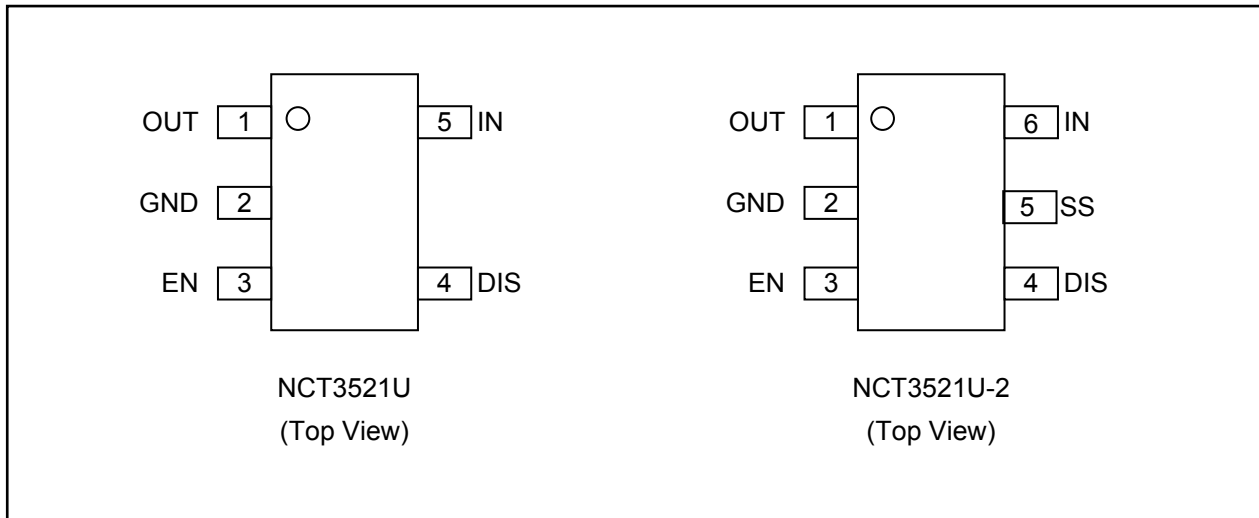

3521U-2	3521U	PIN NAME	I/O	FUNCTION
1	1	OUT	O	<b>Output Voltage.</b> This pin is the N-MOSFET Source that deliver the voltage to output. Connecting a 0.1uF or greater ceramic capacitor from this pin to GND as close to the chip as possible.
2	2	GND		<b>GND.</b>
3	3	EN	I	<b>Enable.</b> High enable. Pulling this pin to the logic low will disable the chip.
4	4	DIS	I	<b>Discharge.</b> Drain of internal N-MOSFET. This pin will active when chip is disabled. By connecting a resistor from DIS to OUT pin, the voltage of OUT can be sink from this pin when chip is disabled.
5		SS	I	<b>Soft-start.</b> Placing a capacitor from this pin to GND can set the ramp up time.

6	5	IN	I	<p><b>Input Voltage.</b> This pin is the N-MOSFET Drain that supplies output current and also supplies operating current for the chip. Connecting a 0.1uF or greater ceramic capacitor from this pin to GND as close to the chip as possible.</p>
---	---	----	---	---

### 5. TYPICAL APPLICATION CIRCUIT

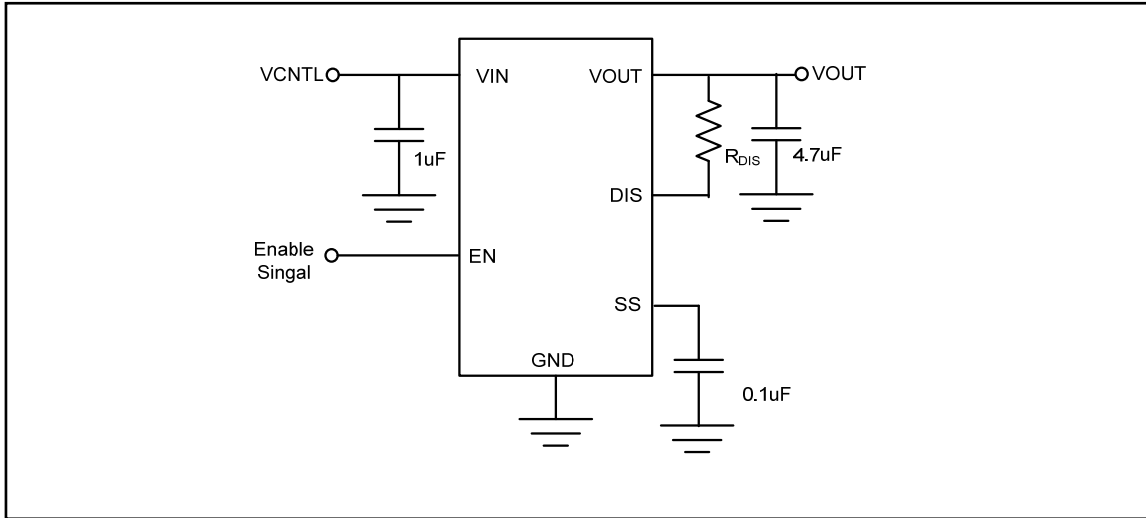

### 6. BLOCK DIAGRAM

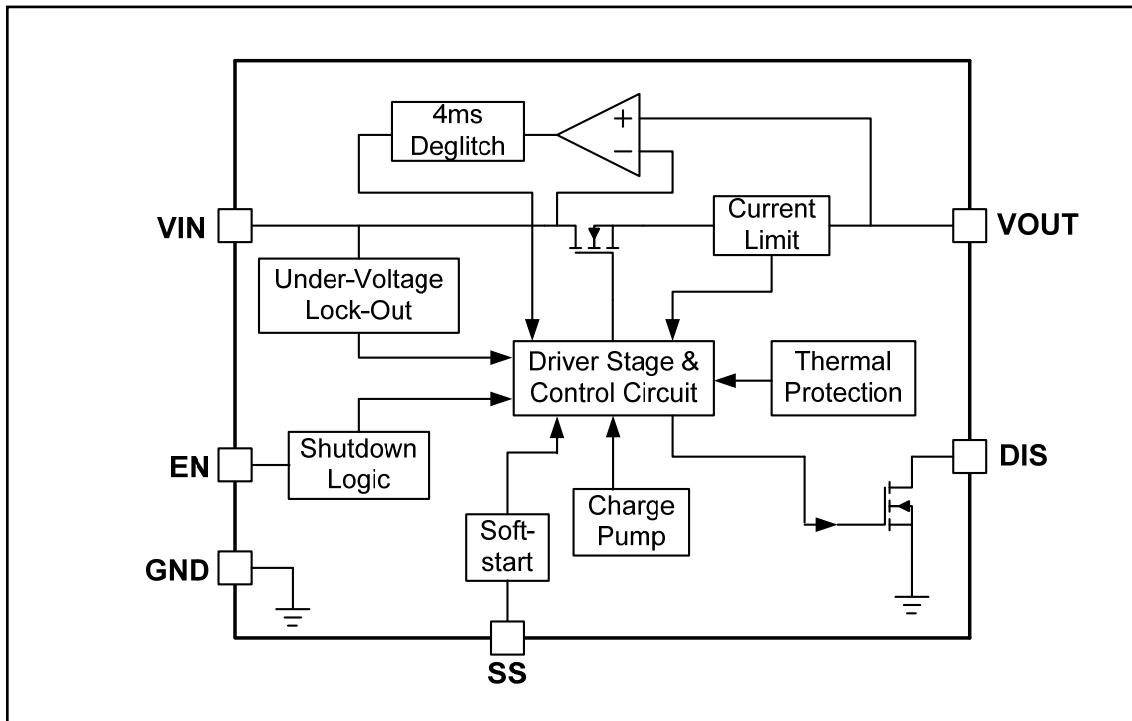

## 7. FUNCTIONAL DESCRIPTION

### 7.1 Product Introduction

The NCT3521 power switch is a N-Channel MOSFET power switches designed for high-side load switching applications.

Once turned on, the soft-start circuitry is activated and the output current is ramped up with linear until it reaches the level required for the output load condition. The typical soft-start time is 1.9mS, it can be changed by capacitor connected in SS pin.

### 7.2 Soft-start

The NCT3521 built-in soft-start function to reduce the inrush current and eliminate the voltage drop at Vin supply voltage when enabling. The soft-start interval is typically 1.9ms.

The soft-start can be adjusted by an external soft-start capacitor connected from SS pin to GND.

### 7.3 Under Voltage Lockout

UVLO (under voltage lockout) prevents the output MOSFET from turning on until VIN exceeds 2.6V typically. After the switch turns on, if the voltage drops below 2.3V typically, UVLO shuts off the output MOSFET. Built-in hysteresis prevents unwanted turn on/off due to input voltage drop from large current surges.

### 7.4 Enable

The NCT3521 is disabled when the EN pin is in the logic low condition. During disabled, The supply current reduce to below 1uA typically. The voltage level of enable pin is also compatible with both TTL and CMOS logic voltage levels. This pin can't floating, please connect logic high or logic low.

### 7.5 Over Current Limit

The NCT3521 contains an independent current limit and the short circuit current protection to prevent unexpected applications. The current limit monitors and controls the Internal MOSFET gate voltage, limiting the output current to higher than 2A typical. The output can be shorted to ground indefinitely without damaging the part.

### 7.6 Thermal-Shutdown Protection

Thermal protection limits power dissipation to prevent IC over temperature exceeds 150°C, the over-temperature protection circuit starts the thermal shutdown function and turns the pass transistor off. The pass transistor turns on again after the junction temperature is falling 50°C (junction temperature  $\leq 100^\circ\text{C}$ ).

### 7.7 Application information

- **Input Capacitor and Output Capacitor**

A minimum of 1uF ceramic capacitor is recommended to be placed directly next to the Vin pin. The Bypass capacitor should be placed as close as possible to the VIN pin to be effective in minimizing transients on the input.

- **Noise Immunity**

In very electrically noisy environments, it is recommended that 0.1uF ceramic capacitors be placed from IN to GND and OUT to GND as close to device pins as possible.

## 8. ELECTRICAL CHARACTERISTICS

### 8.1 Absolute Maximum Ratings

PARAMETER		RATING	UNIT
Input Supply Voltage		-0.3 to 6V	V
Other Pins		-0.3 to 6V	V
Power Dissipation, PD @ TA=25°C		Internal Limited	W
Package Thermal Resistance, SOT23-5/SOT23-6, $\theta_{JA}$		240	°C/W
Storage Temperature		-50 to 150	°C
Junction Temperature		150	°C
ESD Protection	Human Body Mode	2	kV
	Machine Mode	200	V
	Latch-up	100	mA

*Note: Exposure to conditions beyond those listed under Absolute Maximum Ratings may adversely affect the life and reliability of the device.*

### 8.2 Recommended Operating Conditions

PARAMETER	RATING	UNIT
Supply Voltage VIN	2.7 to 5.5	V
Operating Temperature	-40 to 85	°C
Junction Temperature	-40 to 125	°C

*Note: Limits are 100% production tested at 25°C. Limits over the operating temperature range are guaranteed through correlation using Statistical Quality Control (SQC) methods.*

### 8.3 DC Electrical Characteristics

( $V_{EN} = V_{IN} = 5V$ ,  $C_{IN} = C_{OUT} = 10\mu F$ ,  $T_A = T_J = 25^\circ C$ , unless otherwise specified)

PARAMETER	SYMBOL	CONDITIONS	MIN	TYP	MAX	UNIT
<b>Supply voltage</b>						
Supply Input Voltage	$V_{IN}$		2.7		5.5	V
$V_{IN}$ Under Voltage Lockout			1.6	2.3	2.6	V
$V_{IN}$ Under Voltage Hysteresis				0.2		V
Output MOS $R_{DS(ON)}$		$I_{OUT} = 0.5A$		80	115	m $\Omega$
Input Supply Current	$I_{IN}$			70	80	$\mu A$
Shutdown Supply Current					1	$\mu A$
Softstart current	$I_{SS}$			55		$\mu A$
<b>Enable</b>						
Enable High Level	$V_{EN}$		1.8			V
Enable Low Level	$V_{SD}$				1.2	V
Supply Current					1	$\mu A$
Output Turn-on Rising Time		$R_L = 10\Omega$ , 90 % Setting	1.3	1.9	2.7	mS
Shutdown Discharge Resistance				30	60	$\Omega$
<b>Over Current Protection</b>						
Current Limit Threshold	$I_{LIMIT}$	$V_{OUT} = 4V$	2.4	3	3.6	A
Output Short-circuit Current		$V_{OUT} = 0V$ , $2.7V < V_{IN} < 5.5V$	0.2	1.3	1.9	A
<b>Reverse Voltage Protection</b>						
Reverse voltage trip level	$V_{OUT-IN}$		95	135	190	mV
Time from reverse voltage condition to MOSFET turn off		$V_{IN} = 5V$	2	4	8	ms
<b>Thermal Protection</b>						
Thermal Shutdown Temperature	$T_{SD}$			150		$^\circ C$
Thermal Shutdown Hysteresis	$T_{SDHYS}$			50		$^\circ C$

### 9. TYPICAL OPERATING WAVEFORMS

(VIN = VEN = 5V, COUT = 1uF, CIN = 1uF, TA = 25°C, unless otherwise specified)

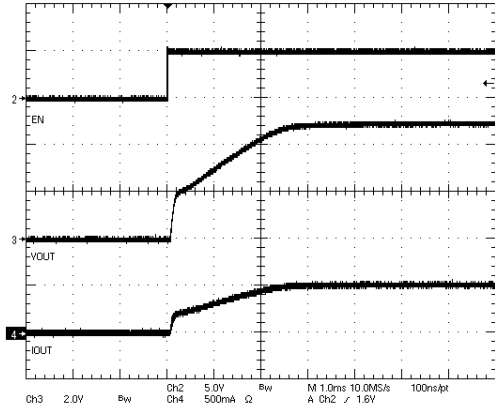

Figure 1. Turn-on and Rising-time

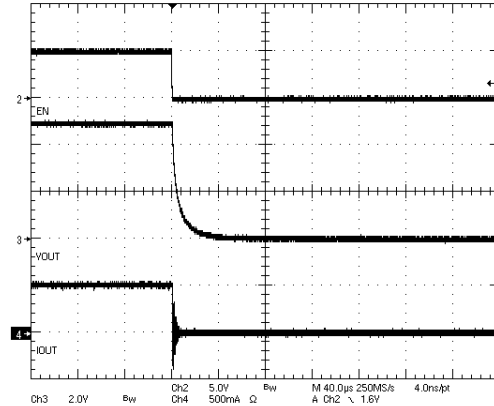

Figure 2. Turn-off and Falling-time

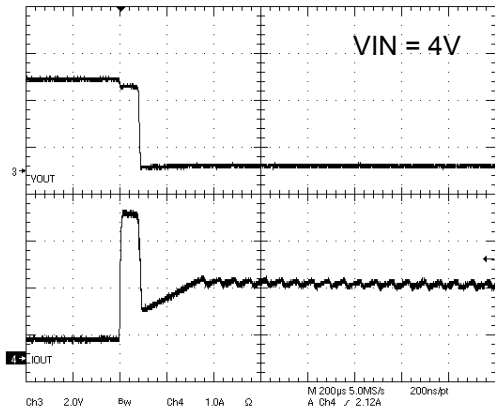

Figure 3. Current Limit Trip and Current Limit

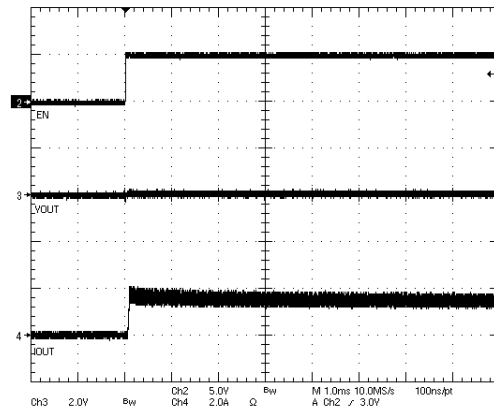

Figure 4. Short-circuit, device enable into short

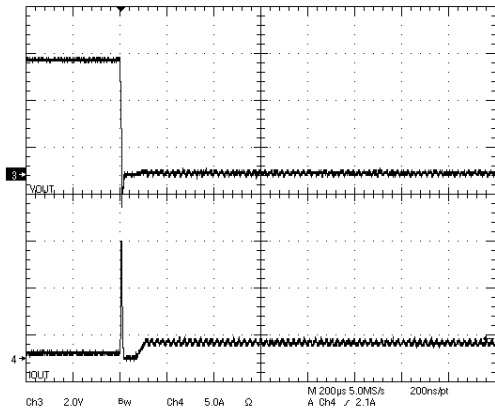

Figure 5. Short-circuit, Normal operation

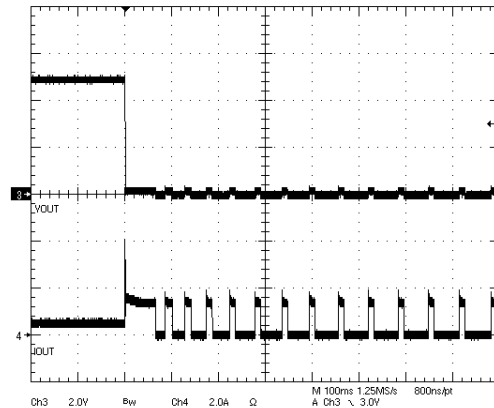

Figure 6. Over-temperature Protection

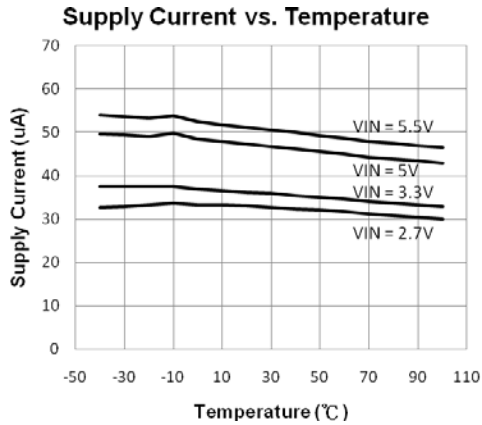

Figure 7. Supply current vs. Temperature

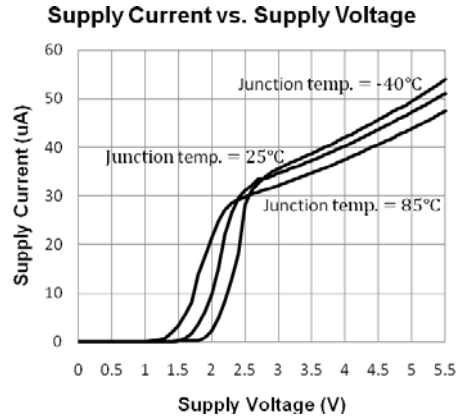

Figure 8. Over-temperature Protection

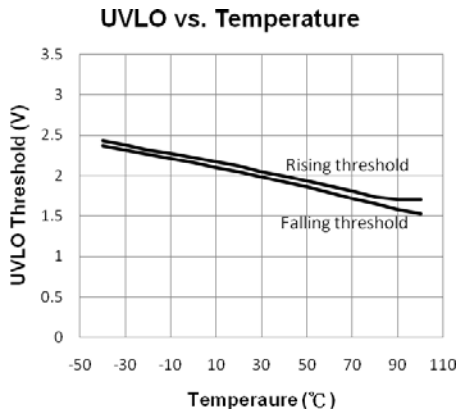

Figure 9 UVLO Threshold vs. Temperature

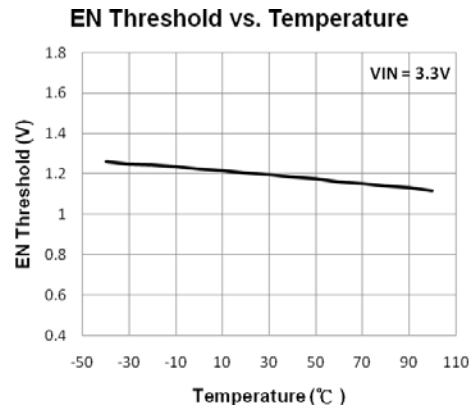

Figure 10. EN Threshold vs. Temperature

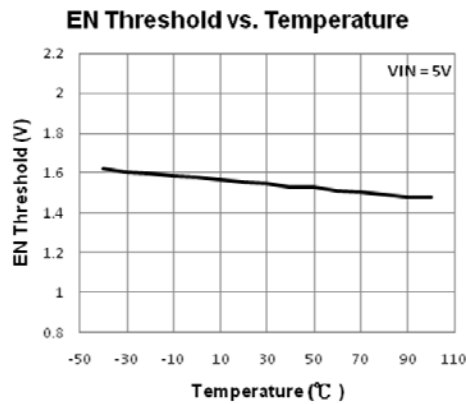

Figure 11 MOSFET  $R_{DS(ON)}$  vs. Temperature

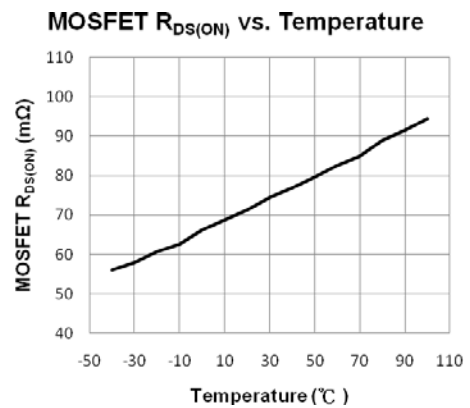
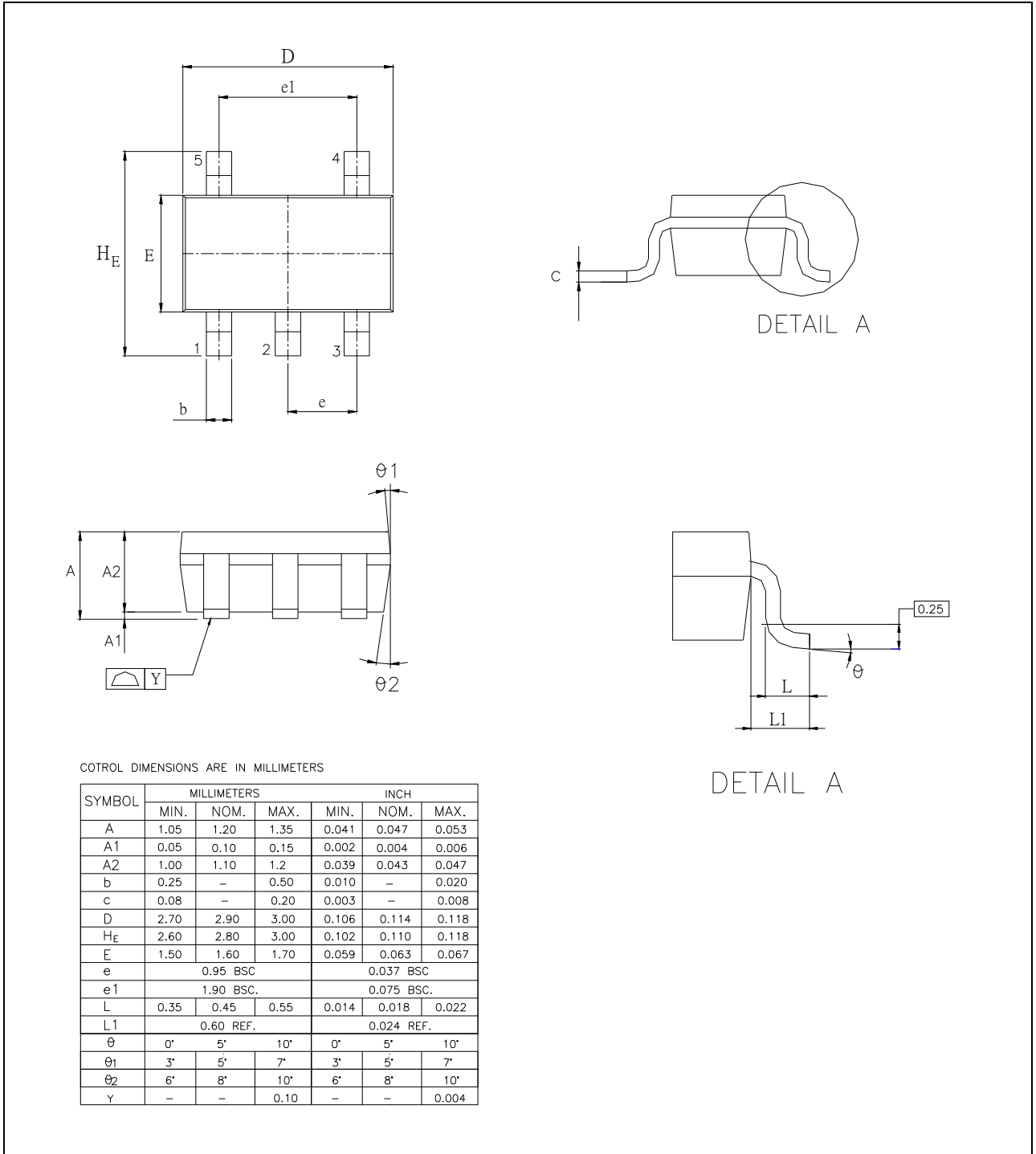

Figure 12. EN Threshold vs. Temperature

### 10. PACKAGE DIMENSION

#### 10.1 NCT3521U SOT23-5 Package Outline



10.2 NCT3521U-2 SOT23-6 Package Outline

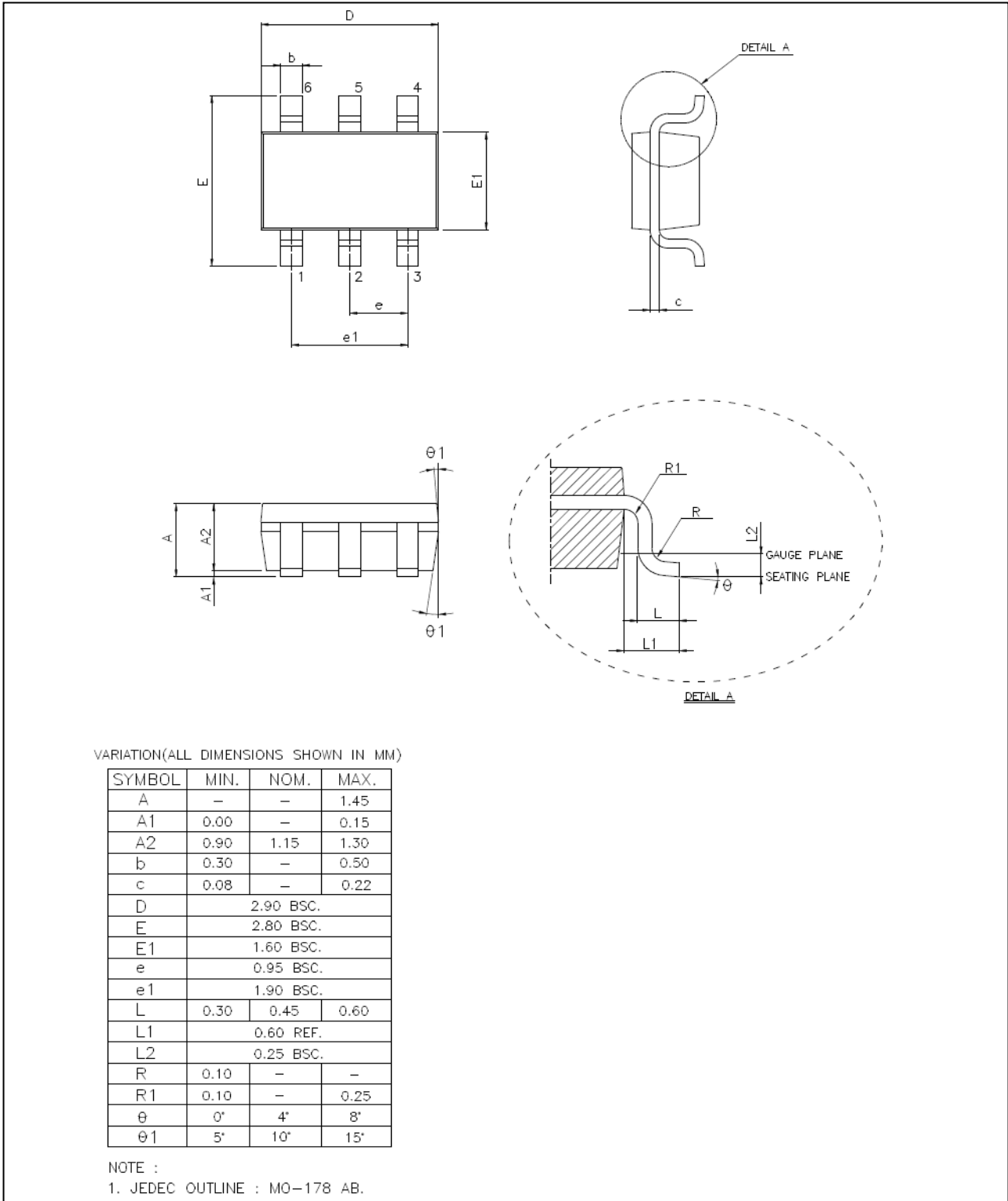

➤ **TAPING SPECIFICATION**

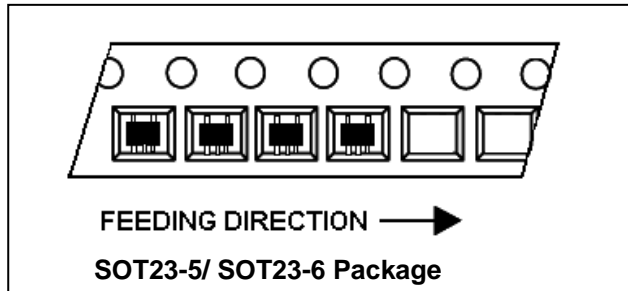

## 11. ORDERING INFORMATION

PART NUMBER	SUPPLIED AS	PACKAGE TYPE	PRODUCTION FLOW
NCT3521U	T Shape: 3,000 units/T&R	SOT23-5 (Green package)	Commercial, 0°C to +70°C
NCT3521U-2		SOT23-6 (Green package)	

## 12. TOP MARKING SPECIFICATION

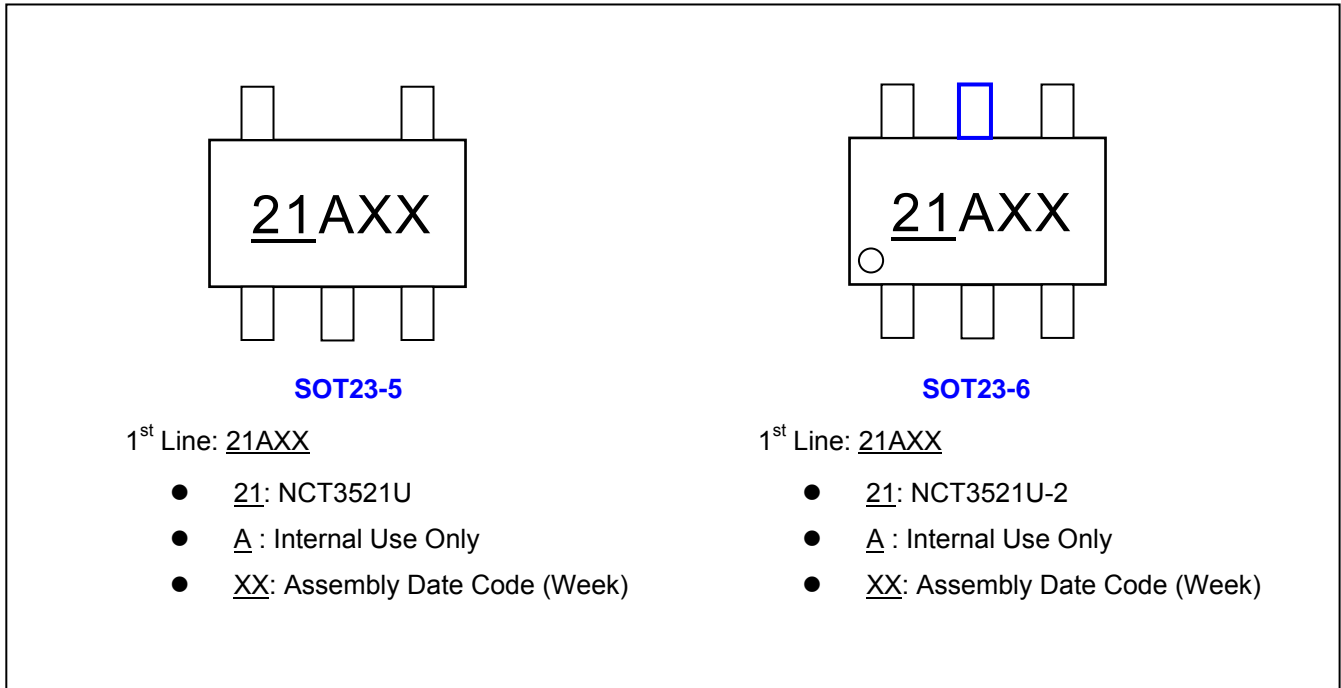

## 13. REVISION HISTORY

VERSION	DATE	PAGE	DESCRIPTION
A0	05/27/2010	All	New Create
A1	06/30/2010	7,8	Updated waveform measurement
A2	11/24/2010	2,3	Correct the typo error
A3	01/06/2011	4	Correct some function description.
A4	06/20/2011	6,8	Correct EN threshold



### **Important Notice**

**Nuvoton Products are neither intended nor warranted for usage in systems or equipment, any malfunction or failure of which may cause loss of human life, bodily injury or severe property damage. Such applications are deemed, "Insecure Usage".**

**Insecure usage includes, but is not limited to: equipment for surgical implementation, atomic energy control instruments, airplane or spaceship instruments, the control or operation of dynamic, brake or safety systems designed for vehicular use, traffic signal instruments, all types of safety devices, and other applications intended to support or sustain life.**

**All Insecure Usage shall be made at customer's risk, and in the event that third parties lay claims to Nuvoton as a result of customer's Insecure Usage, customer shall indemnify the damages and liabilities thus incurred by Nuvoton.**

---

*Please note that all data and specifications are subject to change without notice.  
All the trademarks of products and companies mentioned in this datasheet belong to their respective owners.*