

RK271 27mm Size Metal Shaft Type

High performance potentiometer with excellent operational feel

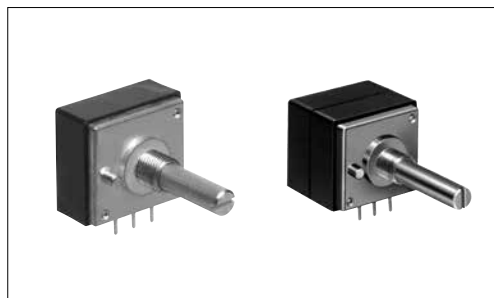

Typical Specifications

Items	Specifications
Total resistance tolerance	±20%
Maximum operating voltage	30V AC
Total rotational angle	300° ±3°
Rotational torque	8 to 35mN·m
Operating life	15,000 cycles
Operating temperature range	-10°C to +70°C

Product Line

Number of resistor elements	Mounting direction	Shaft type	Length of the shaft L ₁ (mm)	Center detent	Total resistance (kΩ)	Resistance taper	Minimum order unit (pcs.)		Products No.	Drawing No.
							Japan	Export		
Single-unit	Horizontal type	Slotted	25	31	100	15A	100	500	RK2711120026	1
				Without					RK271111001T	
Flat		20	2						RK27112A00AK	
		25							RK27112A00CC	
		20		3					RK27112A0A16	
25	RK27112A00B9									

Note

Other varieties are also available. Refer to "Other Specifications" (P.335).

Packing Specifications

Bulk

Number of resistor elements/ Shaft length	Number of packages (pcs.)		Export package measurements (mm)
	1 case /Japan	1 case /export packing	
Single-unit / 25mm Dual-unit / 20mm	100	500	540×380×314
Dual-unit / 25mm			510×360×359





Refer to P.334 for attached parts.
Refer to P.335 for other specifications.
Refer to P.336 for ordering products not listed.
Refer to P.343 for soldering conditions.

Rotary Potentiometers
 Slide Potentiometers
 Metal Shaft
 Insulated Shaft
 Knob Operating
 Through Shaft Type
 Ring Type

RK271 27mm Size Metal Shaft Type

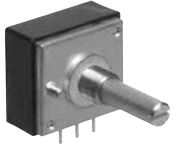
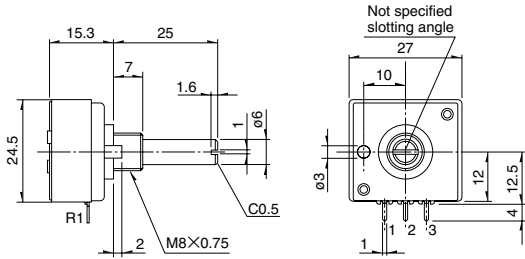
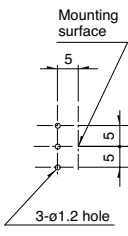
Dimensions

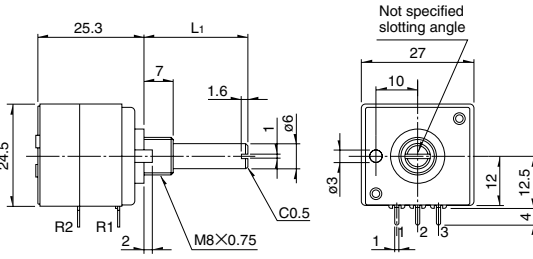
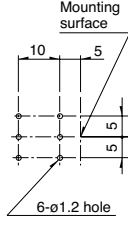
Unit:mm

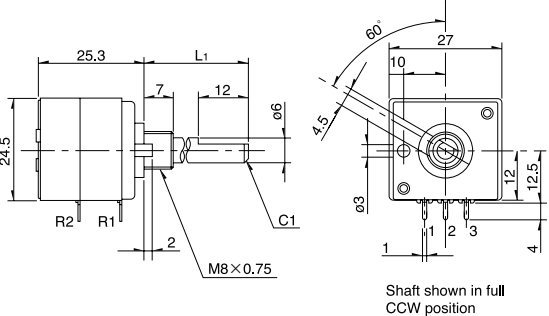
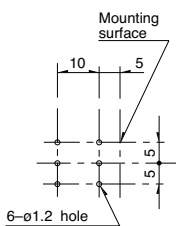
No.	Photo	Style	PC board mounting hole dimensions (Viewed from mounting side)
1	 <p>Single-shaft, single-unit RK27111</p>		
2	 <p>Single-shaft, dual-unit RK27112</p>	<p>L_1 20 25</p> 	
3	 <p>Single-shaft, dual-unit RK27112</p>	<p>L_1 20 25</p> 	

27mm Size Metal Shaft Type / Attached Parts

The following parts are included with the product.

Unit:mm

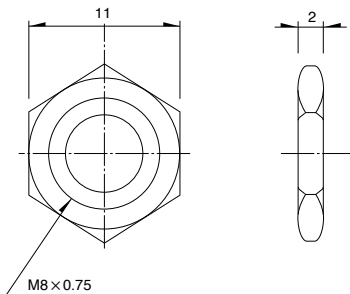
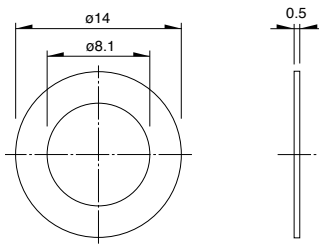
Nut	Washer
	

27mm Size Metal Shaft Type / Other Specifications

In addition to the products listed, we can accommodate the follow specifications.

Products Specification

Type	Model	Mounting height (mm)	Detent variety	Gang error ※
Single-shaft, single-unit	RK27111	12.5	Center 21 31 41	—
Single-shaft, dual-unit	RK27112			−60dB to 0dB within 3dB
Single-shaft, quad-unit	RK27114			−80dB to −60dB within 5dB possible depending on total resistance and taper.

Total Resistance Variety

Total resistance (kΩ)	5	10	20	50	100	250
-----------------------	---	----	----	----	-----	-----

Resistance Taper

Resistance taper	15A	3B
------------------	-----	----

Dimensions of Shaft

1) Slotted type

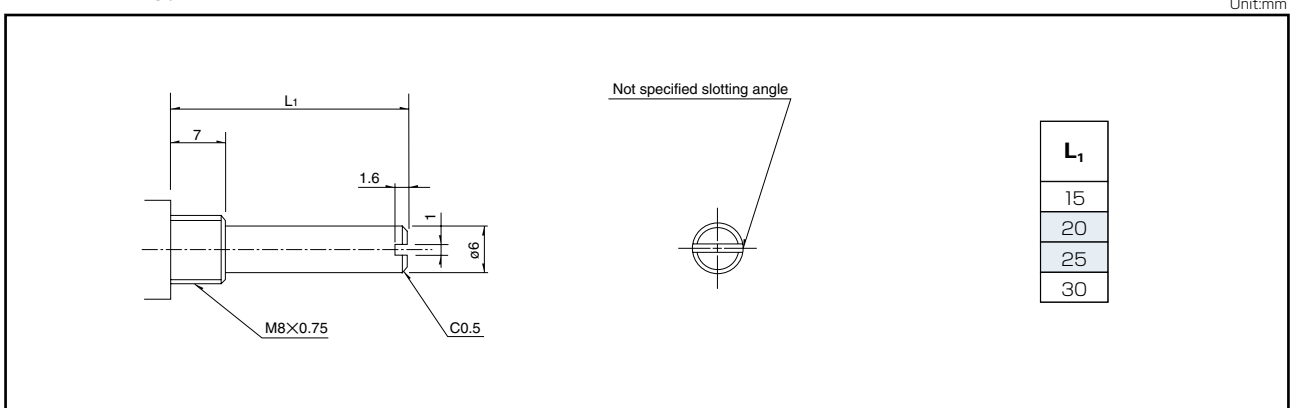

2) Flat type

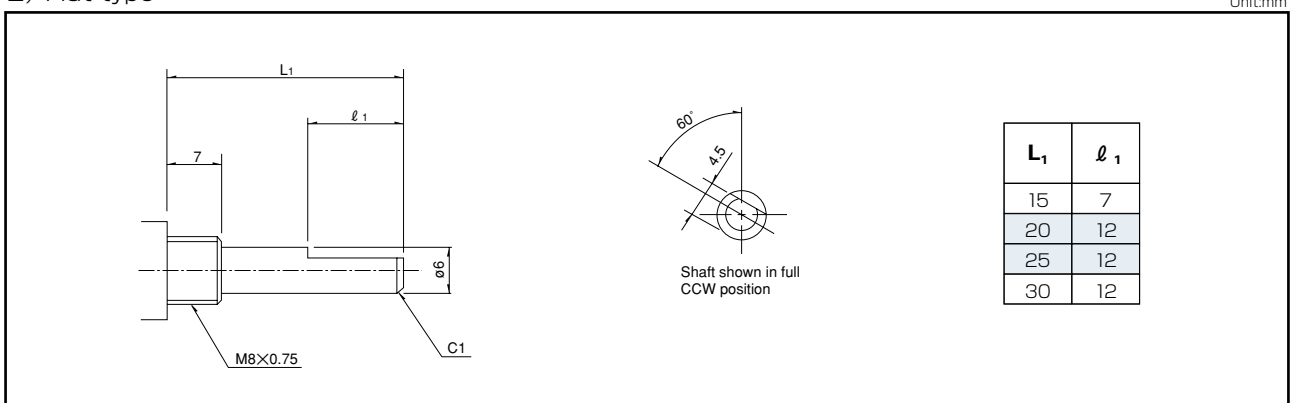

Note

Marked are specifications recommended by Alps Alpine.

※ The gang error of single-shaft, 4-gang potentiometers is the gang error between R1 and R2 and between R3 and R4. The gang error for 5kΩ is within 3dB at −50dB to 0dB.

27mm Size Metal Shaft Type / Ordering Products Not Listed

When ordering product varieties that are not listed, specify referring to the examples below.

Sample Part Number

R K 2 7 1 1 2 A 0 - **S 2 5** - **C 0** - **A 1 0 4**

Model type

Code	Model type
111	Single-unit without detent
112	Single-unit, with detent
12A	Dual-unit for vol. (without detent)
12B	Dual-unit for vol. (with detent)
14A	Quad-unit for vol. (without detent)
14B	Quad-unit for vol. (with detent)

Shaft type

Code	Shaft type
F	Flat
S	Slotted

Length of the shaft L₁ (mm)

Code	Length of the shaft	Code	Length of the shaft
15	15	25	25
20	20	30	30

Detent

Code	Detent	Code	Detent
C0	Without	31	31
C1	Center	41	41
21	21	—	—

Resistance taper

Code	Resistance taper
A	15A
V	3B

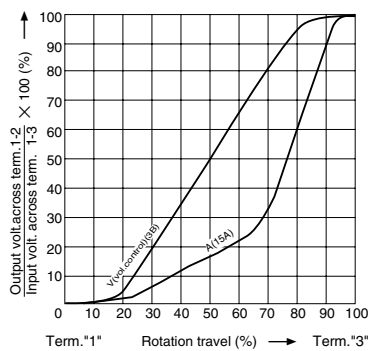











Total resistance

Code	Total resistance (k Ω)	Code	Total resistance (k Ω)
502	5	503	50
103	10	104	100
203	20	254	250

Note

Marked are specifications recommended by Alps Alpine.

Type	16mm size	20mm size	27mm size	50mm size	Rotary motor-driven	
Series	RK163	RK203	RK271	RK501	RK168	
	Single-shaft					
Number of resistor elements	Single/dual	Single	Single/dual/quad	Dual/quad	Dual/quad/5-ganged/6-ganged	
Photo						
Terminal mounting	Horizontal	Vertical	Horizontal			
Fixing method of bushing	Bushing screw clamp					
Operating temperature range	-10°C to +70°C	-40°C to +85°C	-10°C to +70°C			
Operating life	15,000 cycles	30,000 cycles	15,000 cycles			
Available for automotive use	—	○	—	—	—	
Life cycle (availability)						
Electrical performance	Total resistance (kΩ)	5, 10, 20, 50, 100, 200	10	5, 10, 20, 50, 100, 250	10, 20, 50, 100	
	Resistance taper	15A, 1B, 3B, 15C	B	15A, 3B		
	Rated Power	0.1W 0.05W (15A)	0.05W		0.1W	0.05W
	Residual resistance	R≤10kΩ 20Ω max. 10kΩ<R≤50kΩ 30Ω max. 50kΩ<R<3MΩ Nominal total resistance of 0.1% or less%	—	R≤10kΩ 20Ω max. 10kΩ<R<50kΩ 30Ω max. 50kΩ≤R Nominal total resistance of 0.1% or less%	—	—
	Maximum attenuation (Volume control)	5kΩ≤R<10kΩ 70dB min. 10kΩ≤R<50kΩ 80dB min. 50kΩ≤R<100kΩ 90dB min. 100kΩ≤R 100dB min.	—	5kΩ≤R<10kΩ 70dB min. 10kΩ≤R<50kΩ 80dB min. 50kΩ≤R<100kΩ 90dB min. 100kΩ≤R 100dB min.	120dB min.	5kΩ≤R<10kΩ 70dB min. 10kΩ≤R<50kΩ 80dB min. 50kΩ≤R<100kΩ 90dB min. 100kΩ≤R 100dB min.
	Gang error applicable to Dual-unit parts for audio volume control purposes	-40dB to 0dB 3dB max.	—	-70dB to -60dB 3dB max. -60dB to 0dB 2dB max.	-100dB to 0dB 2dB max.	-60dB to -40dB 5dB max. -40dB to 0dB 3dB max.
	Insulation resistance	100MΩ min. 500V DC	10MΩ min. 250V DC	100MΩ min. 500V DC		100MΩ min. 250V DC
	Voltage proof	500V AC for 1minute	300V AC for 1minute	500V AC for 1minute		300V AC for 1minute
	Center-taps	Without				
Mechanical performance	Detent	Without, Cente	17	Without, Center, 21, 31, 41	Without	
	Stopper strength	0.9 N·m	0.5 N·m	0.9 N·m	1.5 N·m	0.9 N·m
	Push-pull strength	100N max.		150N max.	100N max.	
	Vibration	10 to 55 to 10Hz/min., the amplitude is 1.5mm for all the frequencies, in the 3 direction of X, Y and Z for 2 hours respectively				
Shaft style	Serrated type, Flat type, Slotted type	Flat type	Slotted type, Flat type	Slotted type	Flat type	
Terminal style	Insertion, Lead	Insertion				
Attached switch	—	—	—	—	—	
Page	325	330	333	337	339	

Metal Shaft Potentiometers Soldering Conditions	343
Potentiometers Cautions	418
Potentiometers Measurement and Test Methods	420
Potentiometers Resistance Taper	422

Note

○ Indicates applicability to some products in the series.

Rotary Potentiometers
 Slide Potentiometers
 Metal Shaft
 Insulated Shaft
 Knob Operating
 Through Shaft Type
 Ring Type

Reference for Manual Soldering

Series	Tip temperature	Soldering time	No. of solders
RK09L, RK097	350°C max.	3s max.	1 time
RK203	300°C max.	3s max.	1 time
RK119	350±10°C	3 ⁺¹ ₀ s	1 time
RK271	350°C max.	5s max.	1 time
RK501	350±10°C	5 ⁺¹ ₀ s	1 time
RK163	350°C max.	5s max.	1 time
RK168	Potentiometer terminal	300°C max.	3s max.
	Motor terminal	350°C max.	2s max.

Reference for Dip Soldering

Series	Preheating		Dip soldering		No. of solders
	Soldering surface temperature	Heating time	Soldering temperature	Soldering time	
RK09L, RK097, RK203	100°C max.	2 min. max.	260±5°C	5±1s	2 time max.
RK501	120±10°C	2 min. max.	260±5°C	5±1s	2 time

Example of Reflow Soldering Condition

Temperature profile

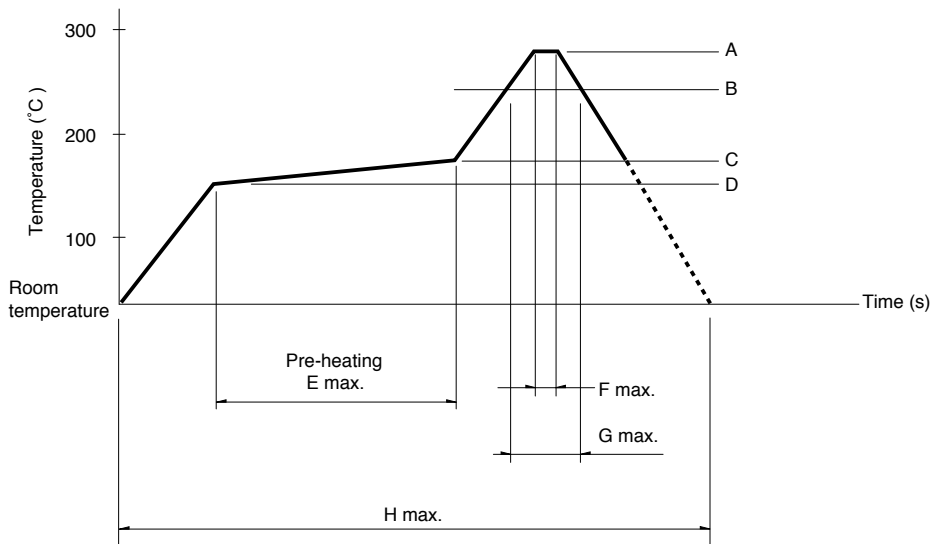

Series	A	B	C	D	E	F	G	H	No. of reflows
RK119	260°C	230°C	180°C	150°C	2 min.	3s	40s	4 min.	2 time max.

Notes

1. When using an infrared reflow oven, solder may sometimes not be applied. Be sure to use a hot air reflow oven or at type that uses infrared rays in combination with hot air.
2. The temperatures given above are the maximum temperatures at the terminals of the potentiometer when employing a hot air reflow method. The temperature of the PC board and the surface temperature of the potentiometer may vary greatly depending on the PC board material, its size and thickness. Ensure that the surface temperature of the potentiometer does not rise to 250°C or greater.
3. Conditions vary to some extent depending on the type of reflow bath used. Be sure to give due consideration to this prior to use.