

# ALUMINUM ELECTROLYTIC CAPACITORS

**HW** series Miniature Sized, High Ripple Current, High Reliability



**NEW**

- Lower impedance at high frequency range.
- Smaller case size and high ripple current.
- Compliant to the RoHS directive (2011/65/EU).



## Specifications

Item	Performance Characteristics							
Category Temperature Range	-40 to +105°C							
Rated Voltage Range	6.3 to 50V							
Rated Capacitance Range	220 to 15000µF							
Capacitance Tolerance	±20% at 120Hz, 20°C							
Leakage Current	After 2 minute's application of rated voltage, current is more than $I = 0.01CV$							
Tangent of loss angle (tan δ)	Rated voltage (V)	6.3	10	16	25	35	50	Measurement frequency : 120Hz, Temperature : 20°C
	tan δ (MAX.)	0.21	0.18	0.15	0.13	0.11	0.10	
Stability at Low Temperature	Rated voltage (V)	6.3	10	16	25	35	50	Measurement frequency : 120Hz
	Impedance ratio $Z_{T-25°C} / Z_{T+20°C}$	2	2	2	2	2	2	
	ZT / Z20 (MAX.)	Z-40°C / Z+20°C	3	3	3	3	3	
Endurance	The specifications listed at right shall be met when the capacitors are restored to 20°C after D.C. bias plus rated ripple current is applied for 10000 hours at 105°C, the peak voltage shall not exceed the rated voltage.							
	Capacitance Change	Within ±25% of the initial capacitance value (6.3V 10V:±30%)						
	tan δ	200% or less than the initial specified value						
	Leakage current	Less than or equal to the initial specified value						
Marking	Printed with white color letter on black sleeve.							

## Radial Lead Type

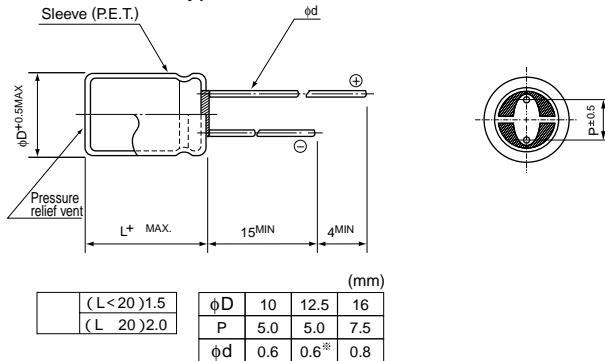

※ In case L > 25 for the φ12.5 dia. unit, lead dia. φ d = 0.8mm.

- Please refer to page 20 about the end seal configuration.

## Type numbering system (Example : 16V 2200µF)

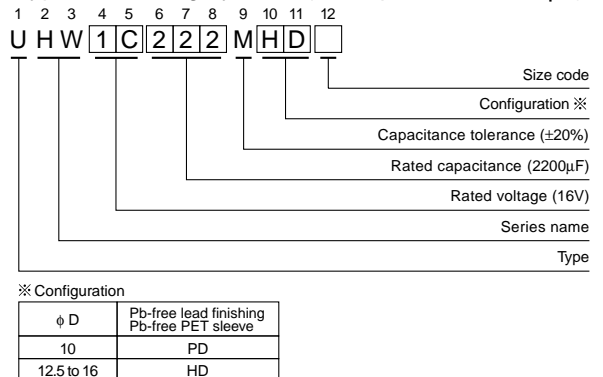

## Frequency coefficient of rated ripple current

Cap. (µF)	Frequency	120Hz	1kHz	10kHz	10kHz or more
220 to 560		0.50	0.85	0.94	1.00
680 to 1800		0.60	0.87	0.95	1.00
2200 to 3900		0.75	0.90	0.95	1.00
4700 to 15000		0.85	0.95	0.98	1.00

Please refer to page 20, 21, 22 about the formed or taped product spec.  
Please refer to page 4 for the minimum order quantity.

- Dimension table in next page.

### ■ Dimensions

V (Code) Item Cap.(μF) Code		6.3 (0J)				10 (1A)			
		Case size φD × L (mm)	Impedance (Ω) MAX.		Rated ripple (mArms) 105°C / 100kHz	Case size φD × L (mm)	Impedance (Ω) MAX.		Rated ripple (mArms) 105°C / 100kHz
			20°C / 100kHz	-10°C / 100kHz			20°C / 100kHz	-10°C / 100kHz	
1200	122					10 × 16	0.030	0.090	2000
1500	152					10 × 16	0.030	0.090	2000
1800	182	10 × 16	0.030	0.090	2000	10 × 20	0.020	0.060	2500
2200	222	10 × 20	0.020	0.060	2500	10 × 25	0.017	0.051	2900
2700	272	10 × 20	0.020	0.060	2500	12.5 × 20	0.017	0.051	2600
3300	332	10 × 25	0.017	0.051	2900	12.5 × 20	0.017	0.051	2600
3900	392	12.5 × 20	0.017	0.051	2600	12.5 × 25	0.015	0.045	3200
4700	472	12.5 × 25	0.015	0.045	3200	12.5 × 31.5	0.012	0.036	3795
		▲16 × 20	0.015	0.045	3200	▲16 × 20	0.015	0.045	3575
5600	562	12.5 × 31.5	0.012	0.036	3795	12.5 × 35.5	0.011	0.033	4120
		▲12.5 × 25	0.015	0.045	3200	▲16 × 25	0.013	0.039	3810
6800	682	12.5 × 31.5	0.011	0.033	3795	16 × 25	0.013	0.039	3810
		▲16 × 20	0.015	0.045	3575				
8200	822	16 × 25	0.013	0.039	3810	16 × 31.5	0.011	0.033	4000
10000	103	16 × 25	0.013	0.039	3810	16 × 31.5	0.011	0.033	4000
12000	123	16 × 31.5	0.011	0.033	4000	16 × 35.5	0.010	0.030	4200
15000	153	16 × 35.5	0.010	0.030	4200				

V (Code) Item Cap.(μF) Code		16 (1C)				25 (1E)			
		Case size φD × L (mm)	Impedance (Ω) MAX.		Rated ripple (mArms) 105°C / 100kHz	Case size φD × L (mm)	Impedance (Ω) MAX.		Rated ripple (mArms) 105°C / 100kHz
			20°C / 100kHz	-10°C / 100kHz			20°C / 100kHz	-10°C / 100kHz	
680	681					10 × 16	0.030	0.090	2000
820	821	10 × 16	0.030	0.090	2000	10 × 20	0.020	0.060	2500
		▲10 × 16	0.030	0.090	2000	▲10 × 16	0.030	0.090	2000
1000	102	10 × 16	0.030	0.090	2000	10 × 20	0.020	0.060	2500
1200	122	10 × 20	0.020	0.060	2500	10 × 25	0.017	0.051	2900
		▲10 × 16	0.030	0.090	2000				
1500	152	10 × 20	0.020	0.060	2500	12.5 × 20	0.017	0.051	2600
1800	182	10 × 25	0.017	0.051	2900	12.5 × 25	0.015	0.045	3200
2200	222	12.5 × 20	0.017	0.051	2600	12.5 × 25	0.015	0.045	3200
		▲16 × 20	0.015	0.045	3575	▲16 × 20	0.015	0.045	3575
2700	272	12.5 × 25	0.015	0.045	3200	12.5 × 31.5	0.012	0.036	3795
		▲16 × 20	0.015	0.045	3575	▲16 × 20	0.015	0.045	3576
3300	332	12.5 × 25	0.015	0.045	3200	12.5 × 35.5	0.011	0.033	4120
		▲16 × 20	0.015	0.045	3575	▲16 × 25	0.013	0.039	3810
3900	392	12.5 × 31.5	0.012	0.036	3795	16 × 25	0.013	0.039	3810
		▲16 × 20	0.015	0.045	3575				
4700	472	12.5 × 35.5	0.011	0.033	4120	16 × 31.5	0.011	0.033	4000
		▲16 × 25	0.013	0.039	3810				
5600	562	16 × 25	0.013	0.039	3810	16 × 35.5	0.010	0.030	4200
6800	682	16 × 31.5	0.011	0.033	4000				
8200	822	16 × 35.5	0.010	0.030	4200				

▲ : In this case, [6] will be put at 12th digit of type numbering system.

## ■ Dimensions

V (Code) Item Cap.(μF) Code		35 (1V)				50 (1H)			
		Case size φD × L (mm)	Impedance (Ω) MAX.		Rated ripple (mArms) 105°C / 100kHz	Case size φD × L (mm)	Impedance (Ω) MAX.		Rated ripple (mArms) 105°C / 100kHz
			20°C / 100kHz	-10°C / 100kHz			20°C / 100kHz	-10°C / 100kHz	
220	221					10 × 16	0.042	0.126	1650
270	271					10 × 20	0.030	0.090	2060
330	331					10 × 20	0.030	0.090	2060
390	391	10 × 16	0.030	0.090	2000	10 × 25	0.028	0.084	2420
						▲10 × 20	0.030	0.090	2060
470	471	10 × 16	0.030	0.090	2000	10 × 25	0.028	0.084	2420
						▲12.5 × 20	0.027	0.081	2300
560	561	10 × 20	0.020	0.060	2500	12.5 × 20	0.027	0.081	2300
680	681	10 × 25	0.017	0.051	2900	12.5 × 25	0.023	0.069	2800
		▲10 × 20	0.020	0.060	2500				
820	821	10 × 25	0.017	0.051	2900	12.5 × 25	0.023	0.069	2800
		▲12.5 × 20	0.017	0.051	2600				
1000	102	12.5 × 20	0.017	0.051	2600	12.5 × 31.5	0.020	0.060	3500
						▲16 × 25	0.021	0.063	3270
1200	122	12.5 × 25	0.015	0.045	3200	16 × 25	0.021	0.063	3270
1500	152	16 × 20	0.015	0.045	3575	12.5 × 35.5	0.019	0.057	3810
						▲16 × 25	0.021	0.063	3270
1800	182	12.5 × 31.5	0.012	0.036	3795	16 × 31.5	0.019	0.057	3430
		▲16 × 25	0.013	0.039	3810				
2200	222	12.5 × 35.5	0.011	0.033	4120	16 × 31.5	0.019	0.057	3430
		▲16 × 25	0.013	0.039	3810				
2700	272					16 × 35.5	0.018	0.054	3600
3300	332	16 × 31.5	0.011	0.033	4000				
3900	392	16 × 35.5	0.010	0.030	4200				

▲ : In this case, [6] will be put at 12th digit of type numbering system.