

Dual Color Emitting Diodes, 660 nm and 940 nm

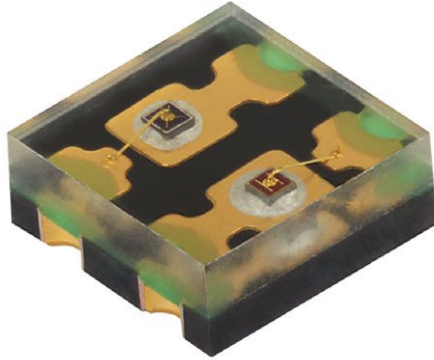

FEATURES

- Package type: surface mount
- Package form: square PCB
- Dimensions (L x W x H in mm): 2 x 2 x 0.87
- Peak wavelength: $\lambda_p = 660$ nm and 940 nm
- High reliability
- High radiant power
- Angle of half intensity: $\phi = \pm 60^\circ$
- Floor life: 168 h, MSL 3, according to J-STD-020
- Lead (Pb)-free reflow soldering
- Material categorization: for definitions of compliance please see www.vishay.com/doc?99912



DESCRIPTION

VSMD66694 is a dual color emitting device with 660 nm and 940 nm peak wavelength. The emitters are based on the [SurfLight™](#) technology, providing high radiant power.

APPLICATIONS

- Wearables
- Health monitoring
- Pulse oximetry

PRODUCT SUMMARY

COMPONENT	COLOR	I_e (mW/sr)	ϕ (deg)	λ_p (nm)	t_r (ns)
VSMD66694	Red	2.3	± 60	660	10
	IR	1.5		940	

Note

- Test conditions see table “Basic Characteristics“

ORDERING INFORMATION

ORDERING CODE	PACKAGING	REMARKS	PACKAGE FORM
VSMD66694	Tape and reel	MOQ: 3000 pcs, 3000 pcs/reel	square PCB

Note

- MOQ: minimum order quantity

ABSOLUTE MAXIMUM RATINGS ($T_{amb} = 25^\circ\text{C}$, unless otherwise specified)

PARAMETER	TEST CONDITION	SYMBOL	COLOR	VALUE	UNIT
Reverse voltage		V_R		5	V
Forward current		I_F	Red	70	mA
			IR	70	
Peak forward current	$t_p/T = 0.1, t_p = 100 \mu\text{s}$	I_{FM}	Red	140	mA
			IR	140	
Surge forward current	$t_p = 100 \mu\text{s}$	I_{FSM}	Red	1	A
			IR	1	
Power dissipation		P_V	Red	161	mW
			IR	119	
Junction temperature		T_j		100	$^\circ\text{C}$
Operating temperature range		T_{amb}		-25 to +85	$^\circ\text{C}$
Storage temperature range		T_{stg}		-25 to +85	$^\circ\text{C}$
Soldering temperature	According fig. 10, J-STD-020	T_{sd}		260	$^\circ\text{C}$
Thermal resistance junction / ambient	J-STD-051	R_{thJA}		390	K/W



Fig. 1 - Power Dissipation Limit vs. Ambient Temperature

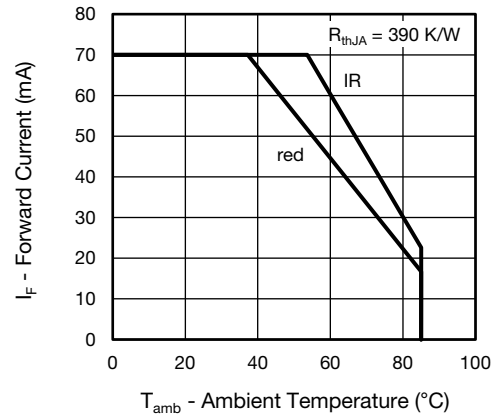
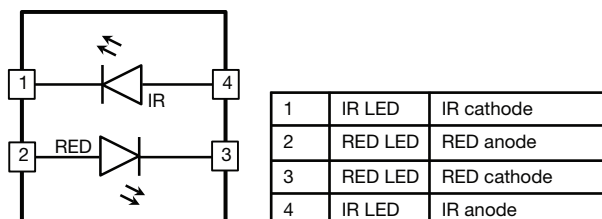

Fig. 2 - Forward Current Limit vs. Ambient Temperature

BASIC CHARACTERISTICS ($T_{amb} = 25\text{ }^{\circ}\text{C}$, unless otherwise specified)							
PARAMETER	TEST CONDITION	SYMBOL	COLOR	MIN.	TYP.	MAX.	UNIT
Forward voltage	$I_F = 20\text{ mA}$, $t_p = 20\text{ ms}$	V_F	Red	-	2.0	2.3	V
			IR	-	1.4	1.7	
Temperature coefficient	$I_F = 20\text{ mA}$	TK_{VF}	Red	-	-2.3	-	mV/K
			IR	-	-2.3	-	
Reverse current		I_R	not designed for reverse operation				μA
Junction capacitance	$V_R = 0\text{ V}$, $f = 1\text{ MHz}$, $E = 0\text{ mW/cm}^2$	C_J	Red	-	7	-	pF
			IR	-	5	-	
Radiant intensity	$I_F = 20\text{ mA}$	I_e	Red	1.9	2.3	-	mW/sr
			IR	0.8	1.5	-	
Radiant power	$I_F = 20\text{ mA}$	ϕ_e	Red	-	9.5	-	mW
			IR	-	8.5	-	
Angle of half intensity	$I_F = 20\text{ mA}$	ϕ		-	± 60	-	deg
Peak wavelength	$I_F = 20\text{ mA}$	λ_p	Red	650	660	670	nm
			IR	920	940	960	
Spectral bandwidth	$I_F = 20\text{ mA}$	$\Delta\lambda$	Red	-	20	-	nm
			IR	-	40	-	
Temperature coefficient of λ_p	$I_F = 20\text{ mA}$	TK_{λ_p}	Red	-	0.2	-	nm/K
			IR	-	0.3	-	
Rise time	$I_F = 20\text{ mA}$	t_r	Red	-	10	-	ns
			IR	-	10	-	
Fall time	$I_F = 20\text{ mA}$	t_f	Red	-	10	-	ns
			IR	-	10	-	

CIRCUIT BLOCK DIAGRAM

BASIC CHARACTERISTICS ($T_{amb} = 25\text{ }^{\circ}\text{C}$, unless otherwise specified)

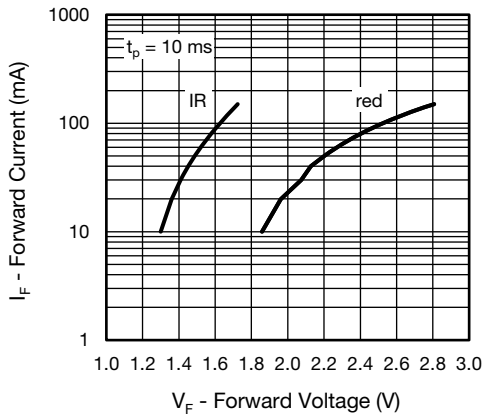

Fig. 3 - Forward Current vs. Forward Voltage

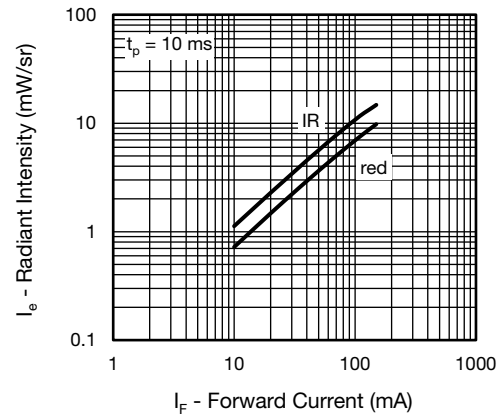

Fig. 6 - Radiant Intensity vs. Forward Current

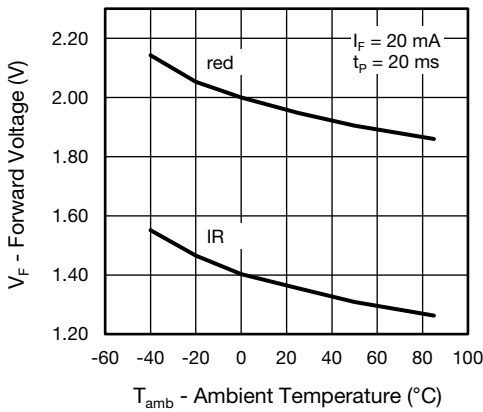

Fig. 4 - Forward Voltage vs. Ambient Temperature

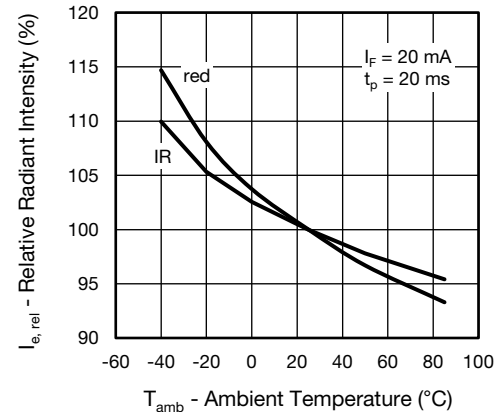

Fig. 7 - Relative Radiant Intensity vs. Ambient Temperature

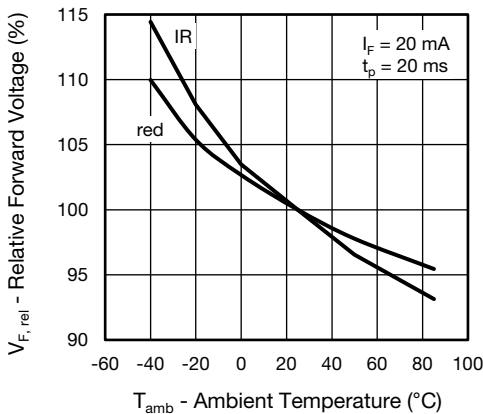

Fig. 5 - Relative Forward Voltage vs. Ambient Temperature

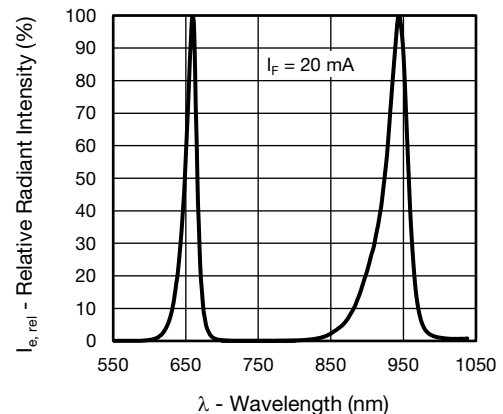

Fig. 8 - Relative Radiant Intensity vs. Wavelength

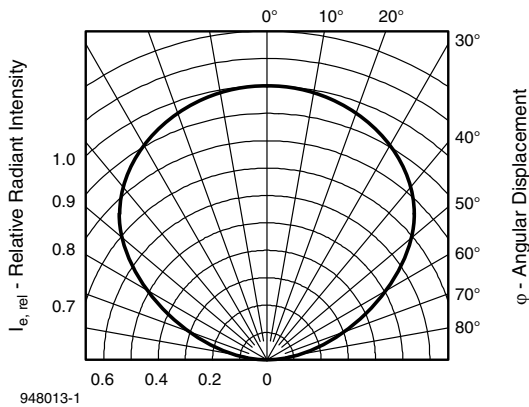

Fig. 9 - Relative Radiant Intensity vs. Angular Displacement

DRYPACK

Devices are packed in moisture barrier bags (MBB) to prevent the products from moisture absorption during transportation and storage. Each bag contains a desiccant.

FLOOR LIFE

Time between soldering and removing from MBB must not exceed the time indicated in J-STD-020:

Moisture sensitivity: level 3

Floor life: 168 h

Conditions: $T_{amb} < 30\text{ }^{\circ}\text{C}$, $RH < 60\text{ }\%$

DRYING

In case of moisture absorption devices should be baked before soldering. Conditions see J-STD-020 or label. Devices taped on reel dry using recommended conditions 192 h at $40\text{ }^{\circ}\text{C}$ (+ $5\text{ }^{\circ}\text{C}$), $RH < 5\text{ }\%$.

REFLOW SOLDER PROFILE

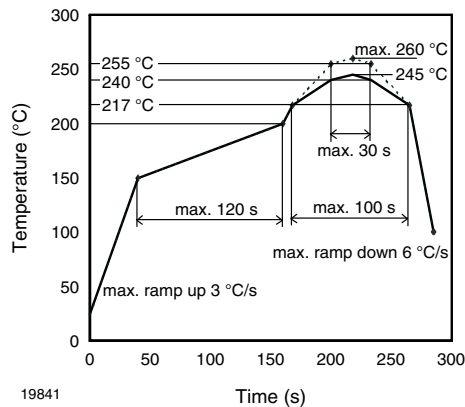
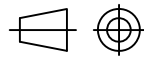
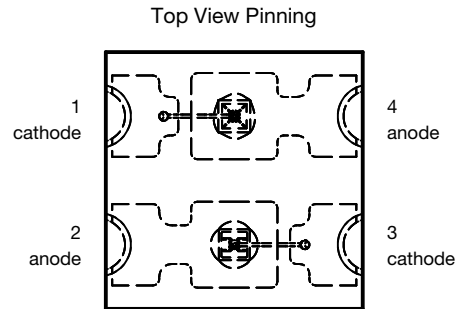
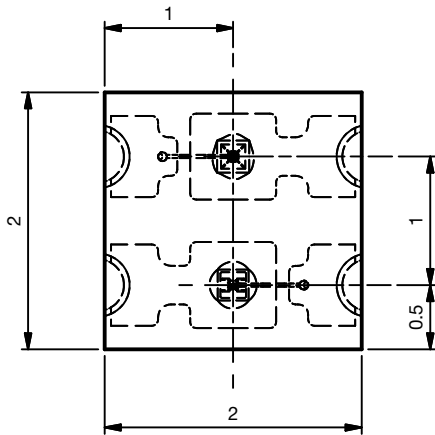
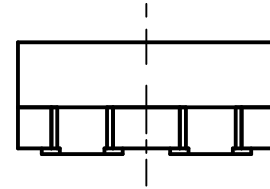
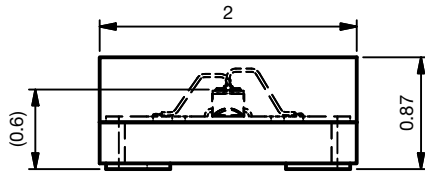

Fig. 10 - Lead (Pb)-free Reflow Solder Profile acc. J-STD-020



PACKAGE DIMENSIONS in millimeters



Technical drawings according to DIN specification

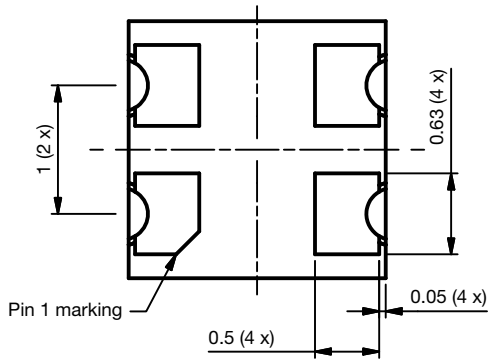

Recommended Footprint

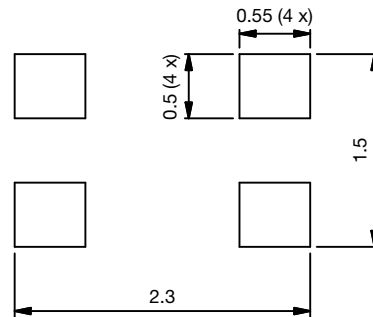

Drawing No.: 6.550-5347.01-4
Issue: 1; 19.02.16

Not indicated tolerances ± 0.1



REEL DIMENSIONS in millimeters

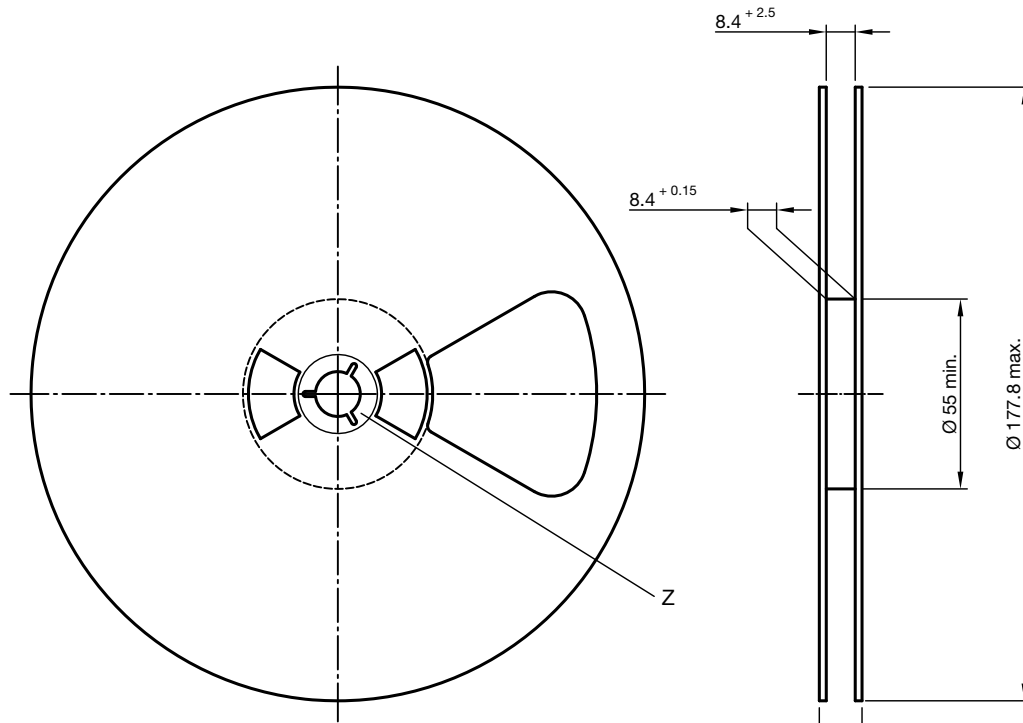

Form of the leave open of the wheel is supplier specific.

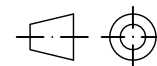
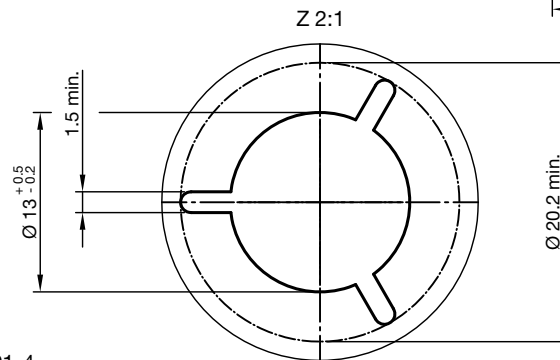

technical drawings according to DIN specifications

Drawing-No.: 9.800-5096.01-4

Issue: 4; 08.03.2016



Disclaimer

ALL PRODUCT, PRODUCT SPECIFICATIONS AND DATA ARE SUBJECT TO CHANGE WITHOUT NOTICE TO IMPROVE RELIABILITY, FUNCTION OR DESIGN OR OTHERWISE.

Vishay Intertechnology, Inc., its affiliates, agents, and employees, and all persons acting on its or their behalf (collectively, "Vishay"), disclaim any and all liability for any errors, inaccuracies or incompleteness contained in any datasheet or in any other disclosure relating to any product.

Vishay makes no warranty, representation or guarantee regarding the suitability of the products for any particular purpose or the continuing production of any product. To the maximum extent permitted by applicable law, Vishay disclaims (i) any and all liability arising out of the application or use of any product, (ii) any and all liability, including without limitation special, consequential or incidental damages, and (iii) any and all implied warranties, including warranties of fitness for particular purpose, non-infringement and merchantability.

Statements regarding the suitability of products for certain types of applications are based on Vishay's knowledge of typical requirements that are often placed on Vishay products in generic applications. Such statements are not binding statements about the suitability of products for a particular application. It is the customer's responsibility to validate that a particular product with the properties described in the product specification is suitable for use in a particular application. Parameters provided in datasheets and/or specifications may vary in different applications and performance may vary over time. All operating parameters, including typical parameters, must be validated for each customer application by the customer's technical experts. Product specifications do not expand or otherwise modify Vishay's terms and conditions of purchase, including but not limited to the warranty expressed therein.

Except as expressly indicated in writing, Vishay products are not designed for use in medical, life-saving, or life-sustaining applications or for any other application in which the failure of the Vishay product could result in personal injury or death. Customers using or selling Vishay products not expressly indicated for use in such applications do so at their own risk. Please contact authorized Vishay personnel to obtain written terms and conditions regarding products designed for such applications.

No license, express or implied, by estoppel or otherwise, to any intellectual property rights is granted by this document or by any conduct of Vishay. Product names and markings noted herein may be trademarks of their respective owners.

Material Category Policy

Vishay Intertechnology, Inc. hereby certifies that all its products that are identified as RoHS-Compliant fulfill the definitions and restrictions defined under Directive 2011/65/EU of The European Parliament and of the Council of June 8, 2011 on the restriction of the use of certain hazardous substances in electrical and electronic equipment (EEE) - recast, unless otherwise specified as non-compliant.

Please note that some Vishay documentation may still make reference to RoHS Directive 2002/95/EC. We confirm that all the products identified as being compliant to Directive 2002/95/EC conform to Directive 2011/65/EU.

Vishay Intertechnology, Inc. hereby certifies that all its products that are identified as Halogen-Free follow Halogen-Free requirements as per JEDEC JS709A standards. Please note that some Vishay documentation may still make reference to the IEC 61249-2-21 definition. We confirm that all the products identified as being compliant to IEC 61249-2-21 conform to JEDEC JS709A standards.